

Calculations

Colon Mine Site Structural Fill

Charah, Inc.

Sanford, NC

March 2015

This page intentionally left blank.

Table of Contents

- A. Settlement
 - Total Settlement
 - Elastic Settlement
 - Primary Consolidation Settlement
 - Secondary Compression Settlement
 - Attachments
- B. Stability
 - Slope Stability Analyses
 - Final Cover Veneer Stability (Options 1 and 2)
 - Operational Cover Veneer Stability
- C. Geosynthetics
 - Geosynthetic Stresses
 - Design Anchor Trench
- D. Leachate Collection System
 - Design of Leachate Collection System
 1. Summary of Model Input Data and Results
 2. HELP Model Output Files
 3. Geocomposite Hydraulic Conductivity Determination
 4. Physical Properties of Ash
 5. HELP Model and Supporting Information for Alternative Final Cover
 - Pipe Sizing
 - Pipe Stresses
 - Pipe Orifice Sizing
 - Pipe Perforations
 - Pipe Capacity
 - Leachate Tank Sizing
- E. Stormwater
 - Subcell Divider Berms
 - Stormwater Pipe Perforations and Sizing
 - Stormwater Management System
 - Time of Concentration
 - Perimeter Channels
 - Side Slope Swales
 - Slope Drains
 - Drop Inlets
 - Apron Outlets
 - Reference Material
 - Sediment Basins
 - Calculations
 - Rainfall Data and Curves
 - Outlet Protection
 - NRCS Soils Report
 - USGS Map



F. Earthwork

- Earthwork Calculations
- Reclamation Timeline

G. Financial Assurance

- Financial Assurance Estimate
- Certificate of Insurance

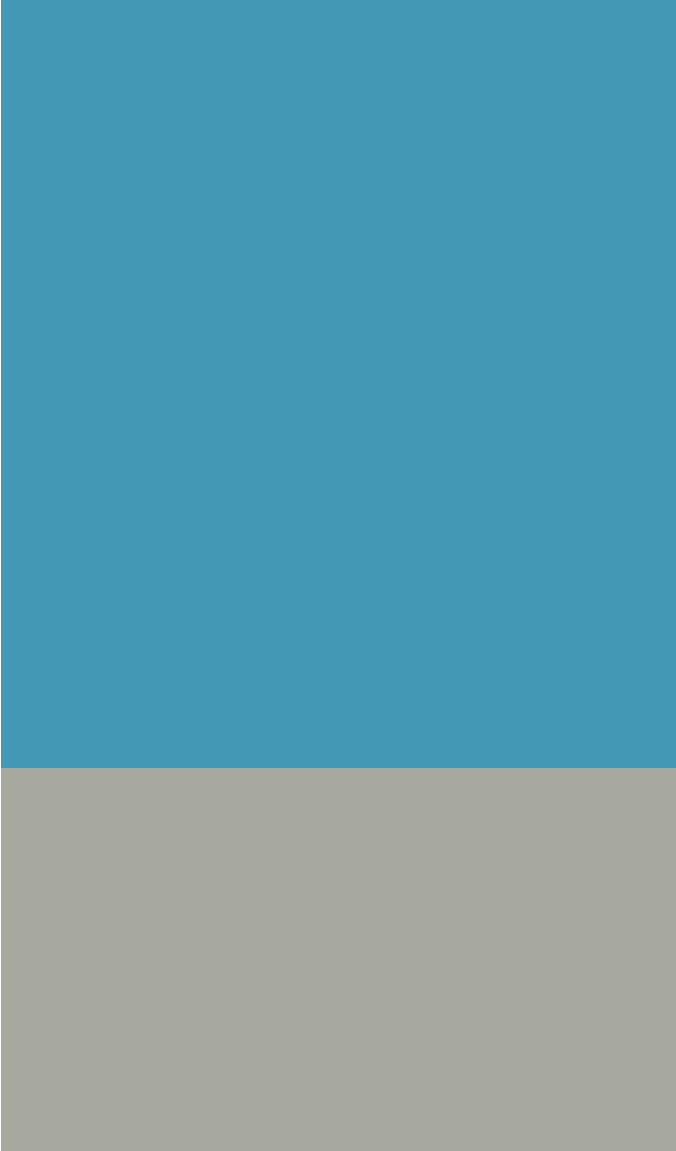

A

Settlement

Total Settlement
Elastic Settlement
Primary Consolidation Settlement
Secondary Compression Settlement
Attachments

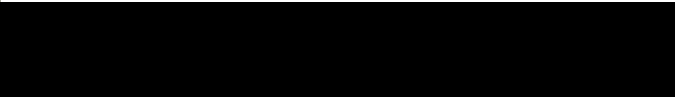



This page intentionally left blank.

HDR Computation

Project: Charah Colon Mine	Computed By: TMY	Date: 10/27/2014
Subject: Permit Application	Checked By: KP	Date: 10/29/2014
Task: Settlement Calculation - Total Settlement	Sheet: 1	Of: 8

Objective:

Estimate the settlement that will occur under the proposed Colon Mine structural fill when the structural fill has reached its final grades.

Background:

As part of the hydrogeological investigation for the site, 20 borings (subsequently converted to piezometers) were drilled in the vicinity of the proposed structural fill to characterize subsurface conditions. Foundation settlement was calculated at 12 of these boring locations (see Attachment A for logs) to determine the effect of settlement on the design liner grades. The elastic settlement was based on correlations with soil type and the estimated vertical stress on the soil. In addition to the elastic settlement, the primary and secondary settlement for clay layers were also estimated. Note these primary consolidation settlement calculations are conservative since they assume the foundation clays are normally consolidated and do not account for stress distribution. The "stiff" description of the foundation clay indicates that the clay is probably overconsolidated and therefore anticipated consolidation settlement is less than calculated.

References:

1. Naval Facilities Engineering Command (NAVFAC) (1986). *Design Manual 7.01 - Soil Mechanics* .
2. Geotrack Technologies, Inc. (2014). Physical Characterization Testing of Coal Combustion By-Products, Riverbend Steam Station
3. Qian, X., Koerner, R. M., & Gray, D. H. (). *Geotechnical Aspects of Landfill Design and Construction* . Upper Saddle River, New Jersey: Prentice Hall.

Steps - Primary Consolidation (Clay Soils)

1. Estimate the total settlement (Z_T) for each layer using the elastic settlement (Z_e), primary consolidation settlement (Z_c), secondary consolidation settlement (Z_α) and equation 12.24 (page 470) below from Reference 3.

$$Z_T = Z_e + Z_c + Z_\alpha$$

2. Repeat Step 1 for each soil layer. Add the total settlement for each layer together to get the total estimated settlement at that location based on information from the boring logs, recent surveys, and seasonal high groundwater levels.

$$Z_{T\ Total} = Z_{T\ layer\ n} + Z_{T\ layer\ n+1}$$

HDR Computation

Project: Charah Colon Mine	Computed By: TMY	Date: 10/27/2014
Subject: Permit Application	Checked By: KP	Date: 10/29/2014
Task: Settlement Calculation - Total Settlement	Sheet: 2	Of: 8

Calculations

MW PZ-3

Layer	Boring Log Description	From Previous Calculations			Step 1
		Elastic Layer Settlement, Z_e (ft)	Primary Consolidation Settlement of Clay, Z_c (ft)	Secondary Compression Settlement of Caly Layer, Z_{α} (ft)	Total Settlement, Z_T (ft)
1	Hard, Reddish-brown, clayey silt	0.07	0.00	0.00	0.07
2	PWR	0.00	0.00	0.00	0.00
3	0	0.00	0.00	0.00	0.00
4	0	0.00	0.00	0.00	0.00
5	0	0.00	0.00	0.00	0.00
6	0	0.00	0.00	0.00	0.00
7	0	0.00	0.00	0.00	0.00

Step 2: Total Estimated Settlement for MW PZ-3 0.07 ft

MW PZ-4

Layer	Boring Log Description	From Previous Calculations			Step 1
		Elastic Layer Settlement, Z_e (ft)	Primary Consolidation Settlement of Clay, Z_c (ft)	Secondary Compression Settlement of Caly Layer, Z_{α} (ft)	Total Settlement, Z_T (ft)
1	Stiff, Brownish-yellow, silty clay	0.11	1.15	0.02	1.28
2	Very stiff, Red, clayey silt	0.12	0.00	0.00	0.12
3	PWR	0.00	0.00	0.00	0.00
4	0	0.00	0.00	0.00	0.00
5	0	0.00	0.00	0.00	0.00
6	0	0.00	0.00	0.00	0.00
7	0	0.00	0.00	0.00	0.00

Step 2: Total Estimated Settlement for MW PZ-4 1.4 ft

HDR Computation

Project: Charah Colon Mine	Computed By: TMY	Date: 10/27/2014
Subject: Permit Application	Checked By: KP	Date: 10/29/2014
Task: Settlement Calculation - Total Settlement	Sheet: 3	Of: 8

MW PZ-6

Layer	Boring Log Description	From Previous Calculations			Step 1
		Elastic Layer Settlement, Z_e (ft)	Primary Consolidation Settlement of Clay, Z_c (ft)	Secondary Compression Settlement of Caly Layer, Z_{α} (ft)	Total Settlement, Z_T (ft)
1	Very stiff, Dark reddish-gray, silty clay (above GW)	0.19	0.53	0.03	0.75
2	Very stiff, Dark reddish-gray, silty clay (below GW)	0.06	0.16	0.01	0.23
3	PWR	0.00	0.00	0.00	0.00
4	0	0.00	0.00	0.00	0.00
5	0	0.00	0.00	0.00	0.00
6	0	0.00	0.00	0.00	0.00
7	0	0.00	0.00	0.00	0.00

Step 2: Total Estimated Settlement for MW PZ-6 0.98 ft

MW PZ-8

Layer	Boring Log Description	From Previous Calculations			Step 1
		Elastic Layer Settlement, Z_e (ft)	Primary Consolidation Settlement of Clay, Z_c (ft)	Secondary Compression Settlement of Caly Layer, Z_{α} (ft)	Total Settlement, Z_T (ft)
1	Very stiff, Red, gravelly silt (above GW)	0.07	0.00	0.00	0.07
2	Very stiff, Red, gravelly silt (below GW)	0.02	0.00	0.00	0.02
3	PWR	0.00	0.00	0.00	0.00
4	0	0.00	0.00	0.00	0.00
5	0	0.00	0.00	0.00	0.00
6	0	0.00	0.00	0.00	0.00
7	0	0.00	0.00	0.00	0.00

Step 2: Total Estimated Settlement for MW PZ-8 0.09 ft

HDR Computation

Project: Charah Colon Mine	Computed By: TMY	Date: 10/27/2014
Subject: Permit Application	Checked By: KP	Date: 10/29/2014
Task: Settlement Calculation - Total Settlement	Sheet: 4	Of: 8

MW PZ-9

Layer	Boring Log Description	From Previous Calculations			Step 1
		Elastic Layer Settlement, Z_e (ft)	Primary Consolidation Settlement of Clay, Z_c (ft)	Secondary Compression Settlement of Caly Layer, Z_{α} (ft)	Total Settlement, Z_T (ft)
1	Stiff, Yellowish-brown, silty clay	0.09	0.32	0.02	0.43
2	Compact, Weak red, clayey sand (above GW)	0.05	0.00	0.00	0.05
3	Compact, Weak red, clayey sand (below GW)	0.07	0.00	0.00	0.07
4	PWR	0.00	0.00	0.00	0.00
5	0	0.00	0.00	0.00	0.00
6	0	0.00	0.00	0.00	0.00
7	0	0.00	0.00	0.00	0.00

Step 2: Total Estimated Settlement for MW PZ-9 0.55 ft

MW PZ-12

Layer	Boring Log Description	From Previous Calculations			Step 1
		Elastic Layer Settlement, Z_e (ft)	Primary Consolidation Settlement of Clay, Z_c (ft)	Secondary Compression Settlement of Caly Layer, Z_{α} (ft)	Total Settlement, Z_T (ft)
1	PWR	0.00	0.00	0.00	0.00
2	0	0.00	0.00	0.00	0.00
3	0	0.00	0.00	0.00	0.00
4	0	0.00	0.00	0.00	0.00
5	0	0.00	0.00	0.00	0.00
6	0	0.00	0.00	0.00	0.00
7	0	0.00	0.00	0.00	0.00

Step 2: Total Estimated Settlement for MW PZ-12 0 ft

HDR Computation

Project: Charah Colon Mine	Computed By: TMY	Date: 10/27/2014
Subject: Permit Application	Checked By: KP	Date: 10/29/2014
Task: Settlement Calculation - Total Settlement	Sheet: 5	Of: 8

MW PZ-13

Layer	Boring Log Description	From Previous Calculations			Step 1
		Elastic Layer Settlement, Z_e (ft)	Primary Consolidation Settlement of Clay, Z_c (ft)	Secondary Compression Settlement of Caly Layer, Z_{α} (ft)	Total Settlement, Z_T (ft)
1	Stiff, Red, sandy silt	0.06	0.00	0.00	0.06
2	Very hard, red, silty clay (below GW)	0.27	0.69	0.07	1.03
3	PWR	0.00	0.00	0.00	0.00
4	0	0.00	0.00	0.00	0.00
5	0	0.00	0.00	0.00	0.00
6	0	0.00	0.00	0.00	0.00
7	0	0.00	0.00	0.00	0.00

Step 2: Total Estimated Settlement for MW PZ-13 1.09 ft

MW PZ-15

Layer	Boring Log Description	From Previous Calculations			Step 1
		Elastic Layer Settlement, Z_e (ft)	Primary Consolidation Settlement of Clay, Z_c (ft)	Secondary Compression Settlement of Caly Layer, Z_{α} (ft)	Total Settlement, Z_T (ft)
1	Very stiff, red, silty clay	0.14	0.48	0.03	0.65
2	Very hard, red, silty clay (below GW)	0.16	0.43	0.05	0.64
3	PWR	0.00	0.00	0.00	0.00
4	0	0.00	0.00	0.00	0.00
5	0	0.00	0.00	0.00	0.00
6	0	0.00	0.00	0.00	0.00
7	0	0.00	0.00	0.00	0.00

Step 2: Total Estimated Settlement for MW PZ-15 1.29 ft

HDR Computation

Project: Charah Colon Mine	Computed By: TMY	Date: 10/27/2014
Subject: Permit Application	Checked By: KP	Date: 10/29/2014
Task: Settlement Calculation - Total Settlement	Sheet: 6	Of: 8

MW PZ-16

Layer	Boring Log Description	From Previous Calculations			Step 1
		Elastic Layer Settlement, Z_e (ft)	Primary Consolidation Settlement of Clay, Z_c (ft)	Secondary Compression Settlement of Caly Layer, Z_{α} (ft)	Total Settlement, Z_T (ft)
1	Stiff, Strong brown, clayey silt	0.06	0.00	0.00	0.06
2	Stiff, Yellowish-red, silty clay (above GW)	0.14	0.38	0.03	0.55
3	Very hard, Red, silty clay (below GW)	0.22	0.52	0.05	0.79
4	PWR	0.00	0.00	0.00	0.00
5	0	0.00	0.00	0.00	0.00
6	0	0.00	0.00	0.00	0.00
7	0	0.00	0.00	0.00	0.00

Step 2: Total Estimated Settlement for MW PZ-16 1.4 ft

MW PZ-18

Layer	Boring Log Description	From Previous Calculations			Step 1
		Elastic Layer Settlement, Z_e (ft)	Primary Consolidation Settlement of Clay, Z_c (ft)	Secondary Compression Settlement of Caly Layer, Z_{α} (ft)	Total Settlement, Z_T (ft)
1	Very stiff, Red, silty clay	0.06	0.22	0.01	0.29
2	Hard, Red, clayey silt	0.12	0.00	0.00	0.12
3	PWR	0.00	0.00	0.00	0.00
4	0	0.00	0.00	0.00	0.00
5	0	0.00	0.00	0.00	0.00
6	0	0.00	0.00	0.00	0.00
7	0	0.00	0.00	0.00	0.00

Step 2: Total Estimated Settlement for MW PZ-18 0.41 ft

HDR Computation

Project: Charah Colon Mine	Computed By: TMY	Date: 10/27/2014
Subject: Permit Application	Checked By: KP	Date: 10/29/2014
Task: Settlement Calculation - Total Settlement	Sheet: 7	Of: 8

MW PZ-19

Layer	Boring Log Description	From Previous Calculations			Step 1
		Elastic Layer Settlement, Z_e (ft)	Primary Consolidation Settlement of Clay, Z_c (ft)	Secondary Compression Settlement of Caly Layer, Z_{α} (ft)	Total Settlement, Z_T (ft)
1	Medium, Light brownish-gray, silty clay	1.37	0.45	0.02	1.84
2	Hard, Yellowish-brown, clayey silt (below GW)	0.32	0.00	0.00	0.32
3	PWR	0.00	0.00	0.00	0.00
4	0	0.00	0.00	0.00	0.00
5	0	0.00	0.00	0.00	0.00
6	0	0.00	0.00	0.00	0.00
7	0	0.00	0.00	0.00	0.00

Step 2: Total Estimated Settlement for MW PZ-19 2.16 ft

MW PZ-20

Layer	Boring Log Description	From Previous Calculations			Step 1
		Elastic Layer Settlement, Z_e (ft)	Primary Consolidation Settlement of Clay, Z_c (ft)	Secondary Compression Settlement of Caly Layer, Z_{α} (ft)	Total Settlement, Z_T (ft)
1	Stiff, Red, sandy silty clay (above GW)	0.17	0.54	0.04	0.75
2	Stiff, Red, sandy silty clay (below GW)	0.11	0.27	0.04	0.42
3	PWR	0.00	0.00	0.00	0.00
4	0	0.00	0.00	0.00	0.00
5	0	0.00	0.00	0.00	0.00
6	0	0.00	0.00	0.00	0.00
7	0	0.00	0.00	0.00	0.00

Step 2: Total Estimated Settlement for MW PZ-20 1.17 ft

HDR Computation

Project: Charah Colon Mine	Computed By: TMY	Date: 10/27/2014
Subject: Permit Application	Checked By: KP	Date: 10/29/2014
Task: Settlement Calculation - Total Settlement	Sheet: 8	Of: 8

Check Post-Settlement Liner Stresses:

Figure 1 shows the post-settlement basegrade slopes after accounting for the calculated total foundation settlement. Figure 1 shows that the greatest change in slope is anticipated to occur between PZ-16 and the inside base of the south perimeter berm (-1.40%). Assuming a linear relationship between settlement and liner strain along this section of basegrade, the maximum strain due to settlement is anticipated to be 1.40%. From GRI GM-13, the minimum average yield elongation for 60 mil textured HDPE geomembrane is 12%. Therefore, the anticipated strain on the base liner geomembrane will not be excessive.

Conclusion:

The settlement calculations are summarized on Figure 1 provided in the back of the calculations. The figure shows calculated total settlement ranged from zero at PZ-12 where essentially all the surface soils will be stripped down to the partially weathered rock which is assumed to be incompressible to a maximum of 2.16 ft of settlement at PZ-19. Based on the calculated settlement, a minimum of 4' post-settlement separation from groundwater will be maintained between the bottom of the proposed liner system and the seasonal-high water table. Figure 1 also shows the effect of the estimated foundation settlement on the proposed liner grades while conservatively assuming that there will be no settlement at the base of the perimeter berm. The calculated post-settlement grades indicate that positive drainage will be maintained on the liner system.

HDR Computation

Project: Charah Colon Mine	Computed By: TMY	Date: 10/27/2014
Subject: Permit Application	Checked By: KP	Date: 10/29/2014
Task: Settlement Calculation - Elastic Settlement	Sheet: 1	Of: 26

Steps - Elastic Settlement

1. Determine the soil type (using Reference 1 and other references) and height of layer (H_o) based on the boring log, recent survey, and measured groundwater levels. Annotated boring logs for borings located within the footprint of the structural fill are included in Attachment A. Estimated groundwater contours for the site are provided in Attachment B. Top of liner and top of final cover elevations are provided in Attachments C and D, respectively. Assume no settlement occurs within Partially Weathered Rock (PWR).
2. Determine the wet unit weight (γ) based on the soil type and Table 6: Typical Values of Soil Index Properties (page 7.1-22) of Reference 4 provided in Attachment E. Use the average of the range of values in Table 6.
3. Determine the vertical stress (σ_{soil}) of the soil by multiplying the height of the soil by the unit weight from step 2 and subtracting the buoyant force due to the water if the layer is below the water table. If water is not present in the layer, set γ_{water} equal to zero.

$$\sigma_{soil} = \gamma_{soil}H_o - \gamma_{water}H_o$$

4. Determine the vertical stress ($\sigma_{m\ soil}$) of the soil at the midpoint of the soil layer.

$$\sigma_{m\ soil} = \frac{\sigma_{soil}}{2}$$

5. Determine the increment of vertical effective stress of the waste & cover on the soil ($\Delta\sigma_{waste \& \ cover}$) assuming the unit weight of the compacted ash (γ_{ash}) is 83.8 pcf (See Slope Stability Calculations and Ref. 2), the height (H_{ash}) varies across the site as shown in Attachment D, unit weight of the cover (γ_{cover}) is estimated to be 120 pcf and the height of the cover (H_{cover}) is 4 feet on sideslopes and 6 feet on the top slope.

$$\Delta\sigma_{ash \& \ cover} = \gamma_{ash}H_{ash} + \gamma_{cover}H_{cover}$$

6. Determine the total vertical stress due to soil (σ_T) at the midpoint of the soil considering the soil ($\sigma_{m\ soil}$) and soil layers above ($\sigma_{soil\ layers\ above}$).

$$\sigma_T = \sigma_{m\ soil} + \sigma_{soil\ layers\ above}$$

HDR Computation

Project: Charah Colon Mine	Computed By: TMY	Date: 10/27/2014
Subject: Permit Application	Checked By: KP	Date: 10/29/2014
Task: Settlement Calculation - Elastic Settlement	Sheet: 2	Of: 26

7. Convert the total vertical stress (σ_T) from psf to psi.

$$\sigma_{T \text{ psi}} = \sigma_T \times \frac{1 \text{ ft}^2}{144 \text{ in}^2}$$

8. Using the total vertical stress (σ_T) in psi and soil type, look up the elastic modulus of soil (E_s) and Poisson's ratio of soil (ν_s) in the Columns in Table 9.5 (page 310) of Reference 3 (Attachment F). Use 95% density columns for soils classified as dense, stiff or hard and 85% density for others.

9. Convert the elastic modulus of soil (E_s) from psi to psf.

$$E_{S \text{ psf}} = E_s \times \frac{144 \text{ in}^2}{1 \text{ ft}^2}$$

10. Determine the constrained modulus of soil (M_s) using the elastic modulus of soil (E_s) and Poisson's ratio of soil (ν_s) and Equation 12.21 (page 470) of Reference 3.

$$M_s = \frac{E_s(1 - \nu_s)}{(1 + \nu_s)(1 - 2\nu_s)}$$

11. Determine the elastic settlement of soil layer (Z_e) using the initial thickness of the soil layer (H_o), the increment of vertical effective stress ($\Delta\sigma$) and the constrained modulus of soil (M_s) and Equation 12.20 (page 469) of Reference 3.

$$Z_e = \left(\frac{\Delta\sigma}{M_s} \right) H_o$$

12. Repeat Steps 1 - 11 for each layer. Add the elastic settlement for each layer together to get the total estimated elastic settlement at that location based on information from the boring logs, recent surveys, and seasonal high groundwater levels.

$$Z_{e \text{ Total}} = Z_{e \text{ layer } n} + Z_{e \text{ layer } n+1}$$

HDR Computation

Project: Charah Colon Mine	Computed By: TMY	Date: 10/27/2014
Subject: Permit Application	Checked By: KP	Date: 10/29/2014
Task: Settlement Calculation - Elastic Settlement	Sheet: 3	Of: 26

Calculations

MW PZ-3

Top of Final Cover Elevation	328 ft
Top of Liner Elevation	284.0 ft
Natural Ground Elevation	296.20 ft
Depth of Excavation to Top of Liner	12.2 ft
Elevation of Partially Weathered Rock (PWR)	281.20 ft (Assume No Settlement in PWR)
Groundwater Elevation	277.26 ft (Groundwater is Below PWR - does not affect calc.)
Height of Ash & Cover	44 ft (Top of Final Cover - Top of Liner)
Cover Thickness	6 ft
Ash Thickness	38 ft
Unit Weight of Ash	83.8 pcf (Source: Reference 2)
Estimated Unit Weight of Cover	120 pcf
Vertical Stress of Ash & Cover	3,904 psf
Water Density	62.4 pcf

Layer	Boring Log Description	Step 1		Step 2	Step 3	
		Soil Symbol	H _o (ft)	Unit Weight of Soil, γ_{soil} (pcf)	Unit Weight of Water, γ_{water} (pcf)	Vertical stress of Soil, σ_{soil} (psf)
1	Hard, Reddish-brown, clayey silt	MH	2.8	108.5	0	304
2	PWR					0
3						0
4						0
5						0
6						0
7						0

HDR Computation

Project: Charah Colon Mine	Computed By: TMY	Date: 10/27/2014
Subject: Permit Application	Checked By: KP	Date: 10/29/2014
Task: Settlement Calculation - Elastic Settlement	Sheet: 4	Of: 26

MW PZ-3 continued

Layer	Boring Log Description	Step 4	Step 5 (see calculation above)	Step 6	Step 7
		Vertical Stress at midpoint of Soil, $\sigma_{m \text{ soil}}$ (psf)	Increment of Vertical Effective Stress of Ash & Cover, $\Delta\sigma_{\text{ash \& cover}}$ (psf)	Total vertical stress due to soil, σ_T (psf)	Total vertical stress on soil, $\sigma_{T \text{ psi}}$ (psi)
1	Hard, Reddish-brown, clayey silt	152	3,904	152	1
2		0			0
3		0			0
4		0			0
5		0			0
6		0			0
7		0			0

MW PZ-3 continued

Layer	Boring Log Description	Step 8		Step 9	Step 10	Step 11
		E_s (psi)	ν_s	E_s (psf)	M_s (psf)	Z_e (ft)
1	Hard, Reddish-brown, clayey silt	400	0.42	57,600	147,042	0.07
2				0	0	
3				0	0	
4				0	0	
5				0	0	
6				0	0	
7				0	0	

Step 12: Total Estimated Elastic Settlement for MW-PZ-3 0.07 ft

HDR Computation

Project: Charah Colon Mine	Computed By: TMY	Date: 10/27/2014
Subject: Permit Application	Checked By: KP	Date: 10/29/2014
Task: Settlement Calculation - Elastic Settlement	Sheet: 5	Of: 26

MW PZ-4

Top of Final Cover Elevation	329.5 ft
Top of Liner Elevation	294.0 ft
Natural Ground Elevation	296.82 ft
Depth of Excavation to Top of Liner	2.82 ft
Elevation of Partially Weathered Rock (PWR)	281.82 ft (Assume No Settlement in PWR)
Groundwater Elevation	287.50 ft (Groundwater is Below PWR - does not affect calc.)
Height of Ash & Cover	35.5 ft (Top of Final Cover - Top of Liner)
Cover Thickness	6 ft
Ash Thickness	29.5 ft
Unit Weight of Ash	83.8 pcf (Source: Reference 2)
Estimated Unit Weight of Cover	120 pcf
Vertical Stress of Ash & Cover	3,192 psf
Water Density	62.4 pcf

Layer	Boring Log Description	Step 1		Step 2	Step 3	
		Soil Symbol	H _o (ft)	Unit Weight of Soil, γ_{soil} (pcf)	Unit Weight of Water, γ_{water} (pcf)	Vertical stress of Soil, σ_{soil} (psf)
1	Stiff, Brownish-yellow, silty clay	CH	5	113.5	0.0	568
2	Very stiff, Red, clayey silt	MH	7	108.5	62.4	323
3	PWR					0
4						0
5						0
6						0
7						0

HDR Computation

Project: Charah Colon Mine	Computed By: TMY	Date: 10/27/2014
Subject: Permit Application	Checked By: KP	Date: 10/29/2014
Task: Settlement Calculation - Elastic Settlement	Sheet: 6	Of: 26

MW PZ-4 continued

Layer	Boring Log Description	Step 4	Step 5 (see calculation above)	Step 6	Step 7
		Vertical Stress at midpoint of Soil, $\sigma_{m \text{ soil}}$ (psf)	Increment of Vertical Effective Stress of Ash & Cover, $\Delta\sigma_{\text{ash \& cover}}$ (psf)	Total vertical stress due to soil, σ_T (psf)	Total vertical stress on soil, $\sigma_{T \text{ psi}}$ (psi)
1	Stiff, Brownish-yellow, silty clay	284	3,192	284	2
2	Very stiff, Red, clayey silt	162	3,192	730	5
3	PWR	0			0
4		0			0
5		0			0
6		0			0
7		0			0

MW PZ-4 continued

Layer	Boring Log Description	Step 8		Step 9	Step 10	Step 11
		E_s (psi)	ν_s	E_s (psf)	M_s (psf)	Z_e (ft)
1	Stiff, Brownish-yellow, silty clay	400	0.42	57,600	147,042	0.11
2	Very stiff, Red, clayey silt	800	0.35	115,200	184,889	0.12
3	PWR			0	0	
4				0	0	
5				0	0	
6				0	0	
7				0	0	

Step 12: Total Estimated Elastic Settlement for MW PZ-4 0.23 ft

HDR Computation

Project: Charah Colon Mine	Computed By: TMY	Date: 10/27/2014
Subject: Permit Application	Checked By: KP	Date: 10/29/2014
Task: Settlement Calculation - Elastic Settlement	Sheet: 7	Of: 26

MW PZ-6

Top of Final Cover Elevation	334 ft
Top of Liner Elevation	278.0 ft
Natural Ground Elevation	283.48 ft
Depth of Excavation to Top of Liner	5.48 ft
Elevation of Partially Weathered Rock (PWR)	251.78 ft (Assume No Settlement in PWR)
Groundwater Elevation	270.64 ft
Height of Ash & Cover	56 ft (Top of Final Cover - Top of Liner)
Cover Thickness	6 ft
Ash Thickness	50 ft
Unit Weight of Ash	83.8 pcf (Source: Reference 2)
Estimated Unit Weight of Cover	120 pcf
Vertical Stress of Ash & Cover	4,910 psf
Water Density	62.4 pcf

Layer	Boring Log Description	Step 1		Step 2	Step 3	
		Soil Symbol	H _o (ft)	Unit Weight of Soil, γ_{soil} (pcf)	Unit Weight of Water, γ_{water} (pcf)	Vertical stress of Soil, σ_{soil} (psf)
1	Very stiff, Dark reddish-gray, silty clay (above GW)	CL	7	123.5	0.0	865
2	Very stiff, Dark reddish-gray, silty clay (below GW)	CL	3	123.5	62.4	183
3	PWR					0
4						0
5						0
6						0
7						0

HDR Computation

Project: Charah Colon Mine	Computed By: TMY	Date: 10/27/2014
Subject: Permit Application	Checked By: KP	Date: 10/29/2014
Task: Settlement Calculation - Elastic Settlement	Sheet: 8	Of: 26

MW PZ-6 continued

Layer	Boring Log Description	Step 4	Step 5 (see calculation above)	Step 6	Step 7
		Vertical Stress at midpoint of Soil, $\sigma_{m \text{ soil}}$ (psf)	Increment of Vertical Effective Stress of Ash & Cover, $\Delta\sigma_{\text{ash \& cover}}$ (psf)	Total vertical stress due to soil, σ_T (psf)	Total vertical stress on soil, $\sigma_{T \text{ psi}}$ (psi)
1	Very stiff, Dark reddish-gray, silty clay (above GW)	433	4,910	433	3
2	Very stiff, Dark reddish-gray, silty clay (below GW)	92	4,910	958	7
3	PWR	0			0
4		0			0
5		0			0
6		0			0
7		0			0

MW PZ-6 continued

Layer	Boring Log Description	Step 8		Step 9	Step 10	Step 11
		E_s (psi)	ν_s	E_s (psf)	M_s (psf)	Z_e (ft)
1	Very stiff, Dark reddish-gray, silty clay (above GW)	800	0.35	115,200	184,889	0.19
2	Very stiff, Dark reddish-gray, silty clay (below GW)	1,100	0.32	158,400	226,667	0.06
3	PWR			0	0	
4				0	0	
5				0	0	
6				0	0	
7				0	0	

Step 12: Total Estimated Elastic Settlement for MW PZ-6 0.25 ft

HDR Computation

Project: Charah Colon Mine	Computed By: TMY	Date: 10/27/2014
Subject: Permit Application	Checked By: KP	Date: 10/29/2014
Task: Settlement Calculation - Elastic Settlement	Sheet: 9	Of: 26

MW PZ-8

Top of Final Cover Elevation	331.5 ft
Top of Liner Elevation	281.5 ft
Natural Ground Elevation	302.56 ft
Depth of Excavation to Top of Liner	21.06 ft
Elevation of Partially Weathered Rock (PWR)	272.56 ft (Assume No Settlement in PWR)
Groundwater Elevation	274.75 ft
Height of Ash & Cover	50 ft (Top of Final Cover - Top of Liner)
Cover Thickness	6 ft
Ash Thickness	44 ft
Unit Weight of Ash	83.8 pcf (Source: Reference 2)
Estimated Unit Weight of Cover	120 pcf
Vertical Stress of Ash & Cover	4,407 psf
Water Density	62.4 pcf

Layer	Boring Log Description	Step 1		Step 2	Step 3	
		Soil Symbol	H _o (ft)	Unit Weight of Soil, γ_{soil} (pcf)	Unit Weight of Water, γ_{water} (pcf)	Vertical stress of Soil, σ_{soil} (psf)
1	Very stiff, Red, gravelly silt (above GW)	ML	7	108.5	0.0	760
2	Very stiff, Red, gravelly silt (below GW)	ML	2	108.5	62.4	92
3	PWR					0
4						0
5						0
6						0
7						0

HDR Computation

Project: Charah Colon Mine	Computed By: TMY	Date: 10/27/2014
Subject: Permit Application	Checked By: KP	Date: 10/29/2014
Task: Settlement Calculation - Elastic Settlement	Sheet: 10	Of: 26

MW PZ-8 continued

Layer	Boring Log Description	Step 4	Step 5 (see calculation above)	Step 6	Step 7
		Vertical Stress at midpoint of Soil, $\sigma_{m \text{ soil}}$ (psf)	Increment of Vertical Effective Stress of Ash & Cover, $\Delta\sigma_{\text{ash \& cover}}$ (psf)	Total vertical stress due to soil, σ_T (psf)	Total vertical stress on soil, $\sigma_{T \text{ psi}}$ (psi)
1	Very stiff, Red, gravelly silt (above GW)	380	4,407	380	3
2	Very stiff, Red, gravelly silt (below GW)	46	4,407	806	6
3	PWR	0			0
4		0			0
5		0			0
6		0			0
7		0			0

MW PZ-8 continued

Layer	Boring Log Description	Step 8		Step 9	Step 10	Step 11
		Es (psi)	ν_s	E_s (psf)	M_s (psf)	Z_e (ft)
1	Very stiff, Red, gravelly silt (above GW)	2,500	0.29	360,000	471,761	0.07
2	Very stiff, Red, gravelly silt (below GW)	2,500	0.29	360,000	471,761	0.02
3	PWR			0	0	
4				0	0	
5				0	0	
6				0	0	
7				0	0	

Step 12: Total Estimated Elastic Settlement for MW PZ-8 0.09 ft

HDR Computation

Project: Charah Colon Mine	Computed By: TMY	Date: 10/27/2014
Subject: Permit Application	Checked By: KP	Date: 10/29/2014
Task: Settlement Calculation - Elastic Settlement	Sheet: 11	Of: 26

MW PZ-9

Top of Final Cover Elevation	314 ft
Top of Liner Elevation	275.5 ft
Natural Ground Elevation	285.74 ft
Depth of Excavation to Top of Liner	10.24 ft
Elevation of Partially Weathered Rock (PWR)	265.74 ft (Assume No Settlement in PWR)
Groundwater Elevation	269.02 ft
Height of Ash & Cover	38.5 ft (Top of Final Cover - Top of Liner)
Cover Thickness	4 ft
Ash Thickness	34.5 ft
Unit Weight of Ash	83.8 pcf (Source: Reference 2)
Estimated Unit Weight of Cover	120 pcf
Vertical Stress of Ash & Cover	3,371 psf
Water Density	62.4 pcf

Layer	Boring Log Description	Step 1		Step 2	Step 3	
		Soil Symbol	H _o (ft)	Unit Weight of Soil, γ_{soil} (pcf)	Unit Weight of Water, γ_{water} (pcf)	Vertical stress of Soil, σ_{soil} (psf)
1	Stiff, Yellowish-brown, silty clay	CL	4	123.5	0.0	494
2	Compact, Weak red, clayey sand (above GW)	SC	3	115.0	0.0	345
3	Compact, Weak red, clayey sand (below GW)	SC	4	115.0	62.4	210
4	PWR					0
5						0
6						0
7						0

HDR Computation

Project: Charah Colon Mine	Computed By: TMY	Date: 10/27/2014
Subject: Permit Application	Checked By: KP	Date: 10/29/2014
Task: Settlement Calculation - Elastic Settlement	Sheet: 12	Of: 26

MW PZ-9 continued

Layer	Boring Log Description	Step 4	Step 5 (see calculation above)	Step 6	Step 7
		Vertical Stress at midpoint of Soil, $\sigma_{m \text{ soil}}$ (psf)	Increment of Vertical Effective Stress of Ash & Cover, $\Delta\sigma_{\text{ash \& cover}}$ (psf)	Total vertical stress due to soil, σ_T (psf)	Total vertical stress on soil, $\sigma_{T \text{ psi}}$ (psi)
1	Stiff, Yellowish-brown, silty clay	247	3,371	247	2
2	Compact, Weak red, clayey sand (above GW)	173	3,371	667	5
3	Compact, Weak red, clayey sand (below GW)	105	3,371	945	7
4		0			0
5		0			0
6		0			0
7		0			0

MW PZ-9 continued

Layer	Boring Log Description	Step 8		Step 9	Step 10	Step 11
		Es (psi)	ν_s	E_s (psf)	M_s (psf)	Z_e (ft)
1	Stiff, Yellowish-brown, silty clay	400	0.42	57,600	147,042	0.09
2	Compact, Weak red, clayey sand (above GW)	800	0.35	115,200	184,889	0.05
3	Compact, Weak red, clayey sand (below GW)	800	0.35	115,200	184,889	0.07
4				0	0	
5				0	0	
6				0	0	
7				0	0	

Step 12: Total Estimated Elastic Settlement for MW PZ-9 0.21 ft

HDR Computation

Project: Charah Colon Mine	Computed By: TMY	Date: 10/27/2014
Subject: Permit Application	Checked By: KP	Date: 10/29/2014
Task: Settlement Calculation - Elastic Settlement	Sheet: 13	Of: 26

MW PZ-12

Top of Final Cover Elevation	303 ft
Top of Liner Elevation	269.5 ft
Natural Ground Elevation	284.32 ft
Depth of Excavation to Top of Liner	14.82 ft
Elevation of Partially Weathered Rock (PWR)	269.32 ft (Assume No Settlement in PWR)
	Since Top of Liner el. \approx PWR el. Assume no Elastic Settlement
Groundwater Elevation	253.72 ft (Groundwater is Below PWR - does not affect calc.)
Height of Ash & Cover	33.5 ft (Top of Final Cover - Top of Liner)
Cover Thickness	4 ft
Ash Thickness	29.5 ft
Unit Weight of Ash	83.8 pcf (Source: Reference 2)
Estimated Unit Weight of Cover	120 pcf
Vertical Stress of Ash & Cover	2,952 psf
Water Density	62.4 pcf

Layer	Boring Log Description	Step 1		Step 2	Step 3	
		Soil Symbol	H _o (ft)	Unit Weight of Soil, γ_{soil} (pcf)	Unit Weight of Water, γ_{water} (pcf)	Vertical stress of Soil, σ_{soil} (psf)
1	PWR				0.0	0
2					0.0	0
3					0.0	0
4						0
5						0
6						0
7						0

HDR Computation

Project: Charah Colon Mine	Computed By: TMY	Date: 10/27/2014
Subject: Permit Application	Checked By: KP	Date: 10/29/2014
Task: Settlement Calculation - Elastic Settlement	Sheet: 14	Of: 26

MW PZ-12 continued

Layer	Boring Log Description	Step 4	Step 5 (see calculation above)	Step 6	Step 7
		Vertical Stress at midpoint of Soil, $\sigma_{m \text{ soil}}$ (psf)	Increment of Vertical Effective Stress of Ash & Cover, $\Delta\sigma_{\text{ash \& cover}}$ (psf)	Total vertical stress due to soil, σ_T (psf)	Total vertical stress on soil, $\sigma_{T \text{ psi}}$ (psi)
1	PWR	0	2,952	0	0
2	0	0	2,952	0	0
3	0	0	2,952	0	0
4		0			0
5		0			0
6		0			0
7		0			0

MW PZ-12 continued

Layer	Boring Log Description	Step 8		Step 9	Step 10	Step 11
		E_s (psi)	ν_s	E_s (psf)	M_s (psf)	Z_e (ft)
1	PWR			0	0	
2	0			0	0	
3	0			0	0	
4				0	0	
5				0	0	
6				0	0	
7				0	0	

Step 12: Total Estimated Elastic Settlement for MW PZ-12 0 ft

HDR Computation

Project: Charah Colon Mine	Computed By: TMY	Date: 10/27/2014
Subject: Permit Application	Checked By: KP	Date: 10/29/2014
Task: Settlement Calculation - Elastic Settlement	Sheet: 15	Of: 26

MW PZ-13

Top of Final Cover Elevation	335.5 ft
Top of Liner Elevation	290.0 ft
Natural Ground Elevation	293.48 ft
Depth of Excavation to Top of Liner	3.48 ft
Elevation of Partially Weathered Rock (PWR)	268.48 ft (Assume No Settlement in PWR)
Groundwater Elevation	283.44 ft
Height of Ash & Cover	45.5 ft (Top of Final Cover - Top of Liner)
Cover Thickness	6 ft
Ash Thickness	39.5 ft
Unit Weight of Ash	83.8 pcf (Source: Reference 2)
Estimated Unit Weight of Cover	120 pcf
Vertical Stress of Ash & Cover	4,030 psf
Water Density	62.4 pcf

Layer	Boring Log Description	Step 1		Step 2	Step 3	
		Soil Symbol	H _o (ft)	Unit Weight of Soil, γ_{soil} (pcf)	Unit Weight of Water, γ_{water} (pcf)	Vertical stress of Soil, σ_{soil} (psf)
1	Stiff, Red, sandy silt	ML	6	108.5	0.0	651
2	Very hard, red, silty clay (below GW)	CL	15	123.5	62.4	917
3	PWR					0
4						0
5						0
6						0
7						0

HDR Computation

Project: Charah Colon Mine	Computed By: TMY	Date: 10/27/2014
Subject: Permit Application	Checked By: KP	Date: 10/29/2014
Task: Settlement Calculation - Elastic Settlement	Sheet: 16	Of: 26

MW PZ-13 continued

Layer	Boring Log Description	Step 4	Step 5 (see calculation above)	Step 6	Step 7
		Vertical Stress at midpoint of Soil, $\sigma_{m \text{ soil}}$ (psf)	Increment of Vertical Effective Stress of Ash & Cover, $\Delta\sigma_{\text{ash \& cover}}$ (psf)	Total vertical stress due to soil, σ_T (psf)	Total vertical stress on soil, $\sigma_{T \text{ psi}}$ (psi)
1	Stiff, Red, sandy silt	326	4,030	326	2
2	Very hard, red, silty clay (below GW)	459	4,030	1,111	8
3	PWR	0			0
4		0			0
5		0			0
6		0			0
7		0			0

MW PZ-13 continued

Layer	Boring Log Description	Step 8		Step 9	Step 10	Step 11
		E_s (psi)	ν_s	E_s (psf)	M_s (psf)	Z_e (ft)
1	Stiff, Red, sandy silt	1,800	0.34	259,200	398,955	0.06
2	Very hard, red, silty clay (below GW)	1,100	0.32	158,400	226,667	0.27
3	PWR			0	0	
4				0	0	
5				0	0	
6				0	0	
7				0	0	

Step 12: Total Estimated Elastic Settlement for MW PZ-13 0.33 ft

HDR Computation

Project: Charah Colon Mine	Computed By: TMY	Date: 10/27/2014
Subject: Permit Application	Checked By: KP	Date: 10/29/2014
Task: Settlement Calculation - Elastic Settlement	Sheet: 17	Of: 26

MW PZ-15

Top of Final Cover Elevation	336 ft
Top of Liner Elevation	294.0 ft
Natural Ground Elevation	300.63 ft
Depth of Excavation to Top of Liner	6.63 ft
Elevation of Partially Weathered Rock (PWR)	275.63 ft (Assume No Settlement in PWR)
Groundwater Elevation	287.60 ft
Height of Ash & Cover	42 ft (Top of Final Cover - Top of Liner)
Cover Thickness	6 ft
Ash Thickness	36 ft
Unit Weight of Ash	83.8 pcf (Source: Reference 2)
Estimated Unit Weight of Cover	120 pcf
Vertical Stress of Ash & Cover	3,737 psf
Water Density	62.4 pcf

Layer	Boring Log Description	Step 1		Step 2	Step 3	
		Soil Symbol	H _o (ft)	Unit Weight of Soil, γ_{soil} (pcf)	Unit Weight of Water, γ_{water} (pcf)	Vertical stress of Soil, σ_{soil} (psf)
1	Very stiff, red, silty clay	CL	7	123.5	0.0	865
2	Very hard, red, silty clay (below GW)	CL	10	123.5	62.4	611
3	PWR					0
4						0
5						0
6						0
7						0

HDR Computation

Project: Charah Colon Mine	Computed By: TMY	Date: 10/27/2014
Subject: Permit Application	Checked By: KP	Date: 10/29/2014
Task: Settlement Calculation - Elastic Settlement	Sheet: 18	Of: 26

MW PZ-15 continued

Layer	Boring Log Description	Step 4	Step 5 (see calculation above)	Step 6	Step 7
		Vertical Stress at midpoint of Soil, $\sigma_{m \text{ soil}}$ (psf)	Increment of Vertical Effective Stress of Ash & Cover, $\Delta\sigma_{\text{ash \& cover}}$ (psf)	Total vertical stress due to soil, σ_T (psf)	Total vertical stress on soil, $\sigma_{T \text{ psi}}$ (psi)
1	Very stiff, red, silty clay	433	3,737	433	3
2	Very hard, red, silty clay (below GW)	306	3,737	1,172	8
3	PWR	0			0
4		0			0
5		0			0
6		0			0
7		0			0

MW PZ-15 continued

Layer	Boring Log Description	Step 8		Step 9	Step 10	Step 11
		E_s (psi)	ν_s	E_s (psf)	M_s (psf)	Z_e (ft)
1	Very stiff, red, silty clay	800	0.35	115,200	184,889	0.14
2	Very hard, red, silty clay (below GW)	1,100	0.32	158,400	226,667	0.16
3	PWR			0	0	
4				0	0	
5				0	0	
6				0	0	
7				0	0	

Step 12: Total Estimated Elastic Settlement for MW PZ-15 0.3 ft

HDR Computation

Project: Charah Colon Mine	Computed By: TMY	Date: 10/27/2014
Subject: Permit Application	Checked By: KP	Date: 10/29/2014
Task: Settlement Calculation - Elastic Settlement	Sheet: 19	Of: 26

MW PZ-16

Top of Final Cover Elevation	317 ft
Top of Liner Elevation	273.0 ft
Natural Ground Elevation	270.63 ft
Depth of Excavation to Top of Liner	-2.37 ft (fill will be added to achieve liner grade)
Elevation of Partially Weathered Rock (PWR)	250.63 ft (Assume No Settlement in PWR)
Groundwater Elevation	262.23 ft
Height of Ash & Cover	44 ft (Top of Final Cover - Top of Liner)
Cover Thickness	6 ft
Ash Thickness	38 ft
Unit Weight of Ash	83.8 pcf (Source: Reference 2)
Estimated Unit Weight of Cover	120 pcf
Estimated Unit Weight of Fill	130 pcf
Vertical Stress of Ash & Cover & Fill	4,213 psf
Water Density	62.4 pcf

Layer	Boring Log Description	Step 1		Step 2	Step 3	
		Soil Symbol	H _o (ft)	Unit Weight of Soil, γ_{soil} (pcf)	Unit Weight of Water, γ_{water} (pcf)	Vertical stress of Soil, σ_{soil} (psf)
1	Stiff, Strong brown, clayey silt	MH	2	108.5	0.0	217
2	Stiff, Yellowish-red, silty clay (above GW)	CL	6	123.5	0.0	741
3	Very hard, Red, silty clay (below GW)	CL	12	123.5	62.4	733
4	PWR					0
5						0
6						0
7						0

HDR Computation

Project: Charah Colon Mine	Computed By: TMY	Date: 10/27/2014
Subject: Permit Application	Checked By: KP	Date: 10/29/2014
Task: Settlement Calculation - Elastic Settlement	Sheet: 20	Of: 26

MW PZ-16 continued

Layer	Boring Log Description	Step 4	Step 5 (see calculation above)	Step 6	Step 7
		Vertical Stress at midpoint of Soil, $\sigma_{m \text{ soil}}$ (psf)	Increment of Vertical Effective Stress of Ash & Cover, $\Delta\sigma_{\text{ash \& cover}}$ (psf)	Total vertical stress due to soil, σ_T (psf)	Total vertical stress on soil, $\sigma_{T \text{ psi}}$ (psi)
1	Stiff, Strong brown, clayey silt	109	4,213	109	1
2	Stiff, Yellowish-red, silty clay (above GW)	371	4,213	589	4
3	Very hard, Red, silty clay (below GW)	367	4,213	1,327	9
4		0			0
5		0			0
6		0			0
7		0			0

MW PZ-16 continued

Layer	Boring Log Description	Step 8		Step 9	Step 10	Step 11
		E_s (psi)	ν_s	E_s (psf)	M_s (psf)	Z_e (ft)
1	Stiff, Strong brown, clayey silt	400	0.42	57,600	147,042	0.06
2	Stiff, Yellowish-red, silty clay (above GW)	800	0.35	115,200	184,889	0.14
3	Very hard, Red, silty clay (below GW)	1,100	0.32	158,400	226,667	0.22
4				0	0	
5				0	0	
6				0	0	
7				0	0	

Step 12: Total Estimated Elastic Settlement for MW PZ-16 0.42 ft

HDR Computation

Project: Charah Colon Mine	Computed By: TMY	Date: 10/27/2014
Subject: Permit Application	Checked By: KP	Date: 10/29/2014
Task: Settlement Calculation - Elastic Settlement	Sheet: 21	Of: 26

MW PZ-18

Top of Final Cover Elevation	328 ft
Top of Liner Elevation	279.5 ft
Natural Ground Elevation	292.27 ft
Depth of Excavation to Top of Liner	12.77 ft
Elevation of Partially Weathered Rock (PWR)	272.27 ft (Assume No Settlement in PWR)
Groundwater Elevation	Dry ft (Groundwater is Below PWR - does not affect calc.)
Height of Ash & Cover	48.5 ft (Top of Final Cover - Top of Liner)
Cover Thickness	6 ft
Ash Thickness	42.5 ft
Unit Weight of Ash	83.8 pcf (Source: Reference 2)
Estimated Unit Weight of Cover	120 pcf
Vertical Stress of Ash & Cover	4,282 psf
Water Density	62.4 pcf

Layer	Boring Log Description	Step 1		Step 2	Step 3	
		Soil Symbol	H _o (ft)	Unit Weight of Soil, γ_{soil} (pcf)	Unit Weight of Water, γ_{water} (pcf)	Vertical stress of Soil, σ_{soil} (psf)
1	Very stiff, Red, silty clay	CL	2	123.5	0.0	247
2	Hard, Red, clayey silt	MH	5	108.5	0.0	543
3	PWR					0
4						0
5						0
6						0
7						0

HDR Computation

Project: Charah Colon Mine	Computed By: TMY	Date: 10/27/2014
Subject: Permit Application	Checked By: KP	Date: 10/29/2014
Task: Settlement Calculation - Elastic Settlement	Sheet: 22	Of: 26

MW PZ-18 continued

Layer	Boring Log Description	Step 4	Step 5 (see calculation above)	Step 6	Step 7
		Vertical Stress at midpoint of Soil, $\sigma_{m \text{ soil}}$ (psf)	Increment of Vertical Effective Stress of Ash & Cover, $\Delta\sigma_{\text{ash \& cover}}$ (psf)	Total vertical stress due to soil, σ_T (psf)	Total vertical stress on soil, $\sigma_{T \text{ psi}}$ (psi)
1	Very stiff, Red, silty clay	124	4,282	124	1
2	Hard, Red, clayey silt	272	4,282	520	4
3	PWR	0			0
4		0			0
5		0			0
6		0			0
7		0			0

MW PZ-18 continued

Layer	Boring Log Description	Step 8		Step 9	Step 10	Step 11
		E_s (psi)	ν_s	E_s (psf)	M_s (psf)	Z_e (ft)
1	Very stiff, Red, silty clay	400	0.42	57,600	147,042	0.06
2	Hard, Red, clayey silt	800	0.35	115,200	184,889	0.12
3	PWR			0	0	
4				0	0	
5				0	0	
6				0	0	
7				0	0	

Step 12: Total Estimated Elastic Settlement for MW PZ-18 0.18 ft

HDR Computation

Project: Charah Colon Mine	Computed By: TMY	Date: 10/27/2014
Subject: Permit Application	Checked By: KP	Date: 10/29/2014
Task: Settlement Calculation - Elastic Settlement	Sheet: 23	Of: 26

MW PZ-19

Top of Final Cover Elevation	330.5 ft
Top of Liner Elevation	271.0 ft
Natural Ground Elevation	265.99 ft
Depth of Excavation to Top of Liner	-5.01 ft (fill will be added to achieve liner grade)
Elevation of Partially Weathered Rock (PWR)	250.99 ft (Assume No Settlement in PWR)
Groundwater Elevation	260.55 ft
Height of Ash & Cover	59.5 ft (Top of Final Cover - Top of Liner)
Cover Thickness	6 ft
Ash Thickness	53.5 ft
Unit Weight of Ash	83.8 pcf (Source: Reference 2)
Estimated Unit Weight of Cover	120 pcf
Estimated Unit Weight of Fill	130 pcf
Vertical Stress of Ash & Cover & Fill	5,855 psf
Water Density	62.4 pcf

Layer	Boring Log Description	Step 1		Step 2	Step 3	
		Soil Symbol	H _o (ft)	Unit Weight of Soil, γ_{soil} (pcf)	Unit Weight of Water, γ_{water} (pcf)	Vertical stress of Soil, σ_{soil} (psf)
1	Medium, Light brownish-gray, silty clay	CL	5	123.5	0.0	618
2	Hard, Yellowish-brown, clayey silt (below GW)	MH	10	108.5	62.4	461
3	PWR					0
4						0
5						0
6						0
7						0

HDR Computation

Project: Charah Colon Mine	Computed By: TMY	Date: 10/27/2014
Subject: Permit Application	Checked By: KP	Date: 10/29/2014
Task: Settlement Calculation - Elastic Settlement	Sheet: 24	Of: 26

MW PZ-19 continued

Layer	Boring Log Description	Step 4	Step 5 (see calculation above)	Step 6	Step 7
		Vertical Stress at midpoint of Soil, $\sigma_{m \text{ soil}}$ (psf)	Increment of Vertical Effective Stress of Ash & Cover, $\Delta\sigma_{\text{ash \& cover}}$ (psf)	Total vertical stress due to soil, σ_T (psf)	Total vertical stress on soil, $\sigma_{T \text{ psi}}$ (psi)
1	Medium, Light brownish-gray, silty clay	309	5,855	309	2
2	Hard, Yellowish-brown, clayey silt (below GW)	231	5,855	849	6
3	PWR	0			0
4		0			0
5		0			0
6		0			0
7		0			0

MW PZ-19 continued

Layer	Boring Log Description	Step 8		Step 9	Step 10	Step 11
		Es (psi)	ν_s	E_s (psf)	M_s (psf)	Z_e (ft)
1	Medium, Light brownish-gray, silty clay	100	0.33	14,400	21,336	1.37
2	Hard, Yellowish-brown, clayey silt (below GW)	800	0.35	115,200	184,889	0.32
3	PWR			0	0	
4				0	0	
5				0	0	
6				0	0	
7				0	0	

Step 12: Total Estimated Elastic Settlement for MW PZ-19 1.69 ft

HDR Computation

Project: Charah Colon Mine	Computed By: TMY	Date: 10/27/2014
Subject: Permit Application	Checked By: KP	Date: 10/29/2014
Task: Settlement Calculation - Elastic Settlement	Sheet: 25	Of: 26

MW PZ-20

Top of Final Cover Elevation	328 ft
Top of Liner Elevation	293.5 ft
Natural Ground Elevation	296.51 ft
Depth of Excavation to Top of Liner	3.01 ft
Elevation of Partially Weathered Rock (PWR)	276.51 ft (Assume No Settlement in PWR)
Groundwater Elevation	284.12 ft
Height of Ash & Cover	34.5 ft (Top of Final Cover - Top of Liner)
Cover Thickness	6 ft
Ash Thickness	28.5 ft
Unit Weight of Ash	83.8 pcf (Source: Reference 2)
Estimated Unit Weight of Cover	120 pcf
Vertical Stress of Ash & Cover	3,108 psf
Water Density	62.4 pcf

Layer	Boring Log Description	Step 1		Step 2	Step 3	
		Soil Symbol	H _o (ft)	Unit Weight of Soil, γ_{soil} (pcf)	Unit Weight of Water, γ_{water} (pcf)	Vertical stress of Soil, σ_{soil} (psf)
1	Stiff, Red, sandy silty clay (above GW)	CL	10	123.5	0.0	1,235
2	Stiff, Red, sandy silty clay (below GW)	CL	8	123.5	62.4	489
3	PWR					0
4						0
5						0
6						0
7						0

HDR Computation

Project: Charah Colon Mine	Computed By: TMY	Date: 10/27/2014
Subject: Permit Application	Checked By: KP	Date: 10/29/2014
Task: Settlement Calculation - Elastic Settlement	Sheet: 26	Of: 26

MW PZ-20 continued

Layer	Boring Log Description	Step 4	Step 5 (see calculation above)	Step 6	Step 7
		Vertical Stress at midpoint of Soil, $\sigma_{m \text{ soil}}$ (psf)	Increment of Vertical Effective Stress of Ash & Cover, $\Delta\sigma_{\text{ash \& cover}}$ (psf)	Total vertical stress due to soil, σ_T (psf)	Total vertical stress on soil, $\sigma_{T \text{ psi}}$ (psi)
1	Stiff, Red, sandy silty clay (above GW)	618	3,108	618	4
2	Stiff, Red, sandy silty clay (below GW)	245	3,108	1,481	10
3	PWR	0			0
4		0			0
5		0			0
6		0			0
7		0			0

MW PZ-20 continued

Layer	Boring Log Description	Step 8		Step 9	Step 10	Step 11
		E_s (psi)	ν_s	E_s (psf)	M_s (psf)	Z_e (ft)
1	Stiff, Red, sandy silty clay (above GW)	800	0.35	115,200	184,889	0.17
2	Stiff, Red, sandy silty clay (below GW)	1,100	0.32	158,400	226,667	0.11
3	PWR			0	0	
4				0	0	
5				0	0	
6				0	0	
7				0	0	

Step 12: Total Estimated Elastic Settlement for MW PZ-20 0.28 ft

HDR Computation

Project: Charah Colon Mine	Computed By: TMY	Date: 10/27/2014
Subject: Permit Application	Checked By: KP	Date: 10/29/2014
Task: Settlement Calculation - Primary Consolidation Settlement	Sheet: 1	Of: 20

Steps - Primary Consolidation (Clay Soils)

1. Estimate the initial void ratio (e_{oi}) of the clay layer using the laboratory total porosity (n) values provided on the boring logs (Attachment A). Assume $e_{oi} = 0.65$ for CH material and 0.44 for CL material. Determine e_{oi} as follows:

$$e_{oi} = \frac{n}{1 - n} \quad \text{where } n = \text{effective porosity}$$

2. Estimate the primary compression index using the initial void ratio from Step 1 and the Equation below from Table 3 (page 7.1-224) of Reference 1.

$$C_c = 1.15(e_o - 0.35)$$

3. Conservatively assume the preconsolidation pressure (p_c) is equal to the initial vertical effective stress (σ_o) using the equation below.

$$p_c = \sigma_o = \sigma_{m \text{ soil}} + \sigma_{\text{soil layers above}}$$

4. Determine the primary consolidation using the Equation 12.22 (page 470) below from Reference 3. Conservatively assume the clay is normally consolidated without preconsolidation pressure, therefore assume the recompression index (C_r) is equal to 0.

$$Z_c = C_r \times \frac{H_{oi}}{1 + e_{oi}} \times \log \frac{p_c}{\sigma_o} + C_c \times \frac{H_{oi}}{1 + e_{oi}} \times \log \frac{\sigma_o + \Delta\sigma}{p_c}$$

HDR Computation

Project: Charah Colon Mine	Computed By: TMY	Date: 10/27/2014
Subject: Permit Application	Checked By: KP	Date: 10/29/2014
Task: Settlement Calculation - Primary Consolidation Settlement	Sheet: 2	Of: 20

Where:

Z_c = primary consolidation settlement of clay layer (ft)

H_o = initial thickness of clay layer (ft)

e_{oi} = initial void ratio of clay layer

C_r = recompression index

C_c = primary compression index

σ_o = initial vertical effective stress (lb/ft²)

p_c = preconsolidation pressure (lb/ft²)

$\Delta\sigma$ = increment of vertical effective stress (lb/ft²)

4. Repeat Steps 1 - 4 for each clay layer. Add the primary consolidation settlement for each clay layer together to get the total estimated primary consolidation settlement at that location based on information from the boring logs, recent surveys, and seasonal high groundwater levels.

$$Z_{c\ Total} = Z_{c\ layer\ n} + Z_{c\ layer\ n+1}$$

Calculations

MW PZ-3

Layer	Boring Log Description	From Previous Calculation				
		Soil Symbol	H_o (ft)	Increment of Vertical Effective Stress, $\Delta\sigma$ (psf)	Vertical Stress at midpoint, $\sigma_{m\ soil}$ (psf)	Vertical Stress in soil layer, $\sigma_{soil\ layers}$ (psf)
1	Hard, Reddish-brown, clayey silt	MH	2.8	3,904	152	304
2	PWR	0	0.0	0	0	0
3		0	0.0	0	0	0
4		0	0.0	0	0	0
5		0	0.0	0	0	0
6		0	0.0	0	0	0
7		0	0.0	0	0	0

HDR Computation

Project: Charah Colon Mine	Computed By: TMY	Date: 10/27/2014
Subject: Permit Application	Checked By: KP	Date: 10/29/2014
Task: Settlement Calculation - Primary Consolidation Settlement	Sheet: 3	Of: 20

MW PZ-3 continued

Layer	Boring Log Description	Step 1			Step 2	Step 3
		Minimum Void Ratio, e_{min}	Maximum Void Ratio, e_{max}	Initial Void Ratio, e_{oi}	Primary Compression Index, C_c	Preconsolidation Pressure, p_c (psf)
1	Hard, Reddish-brown, clayey silt					
2	PWR					
3	0					
4	0					
5	0					
6	0					
7	0					

MW PZ-3 continued

Layer	Boring Log Description	Step 3, Continued	Step 4	
		Initial Vertical Effective Stress on Soil, σ_o (psf)	Recompression Index, C_r	Primary Consolidation Settlement of Clay Layer, Z_c (ft)
1	Hard, Reddish-brown, clayey silt			
2	PWR			
3	0			
4	0			
5	0			
6	0			
7	0			

Step 4: Total Estimated Primary Consolidation Settlement for MW PZ-3

0 ft

HDR Computation

Project: Charah Colon Mine	Computed By: TMY	Date: 10/27/2014
Subject: Permit Application	Checked By: KP	Date: 10/29/2014
Task: Settlement Calculation - Primary Consolidation Settlement	Sheet: 4	Of: 20

MW PZ-4

Layer	Boring Log Description	From Previous Calculation				
		Soil Symbol	H _o (ft)	Increment of Vertical Effective Stress, $\Delta\sigma$ (psf)	Vertical Stress at midpoint, $\sigma_{m\ soil}$ (psf)	Vertical Stress in soil layer, $\sigma_{soil\ layers}$ (psf)
1	Stiff, Brownish-yellow, silty clay	CH	5	3,192	284	568
2	Very stiff, Red, clayey silt	MH	7	3,192	162	323
3	PWR	0	0	0	0	0
4	0	0	0	0	0	0
5	0	0	0	0	0	0
6	0	0	0	0	0	0
7	0	0	0	0	0	0

MW PZ-4 continued

Layer	Boring Log Description	Step 1			Step 2	Step 3
		Minimum Void Ratio, e_{min}	Maximum Void Ratio, e_{max}	Initial Void Ratio, e_{oi}	Primary Compression Index, C_c	Preconsolidation Pressure, p_c (psf)
1	Stiff, Brownish-yellow, silty clay			0.65	0.35	284
2	Very stiff, Red, clayey silt					
3	PWR					
4	0					
5	0					
6	0					
7	0					

HDR Computation

Project: Charah Colon Mine	Computed By: TMY	Date: 10/27/2014
Subject: Permit Application	Checked By: KP	Date: 10/29/2014
Task: Settlement Calculation - Primary Consolidation Settlement	Sheet: 5	Of: 20

MW PZ-4 continued

Layer	Boring Log Description	Step 3, Continued	Step 4	
		Initial Vertical Effective Stress on Soil, σ_o (psf)	Recompression Index, C_r	Primary Consolidation Settlement of Clay Layer, Z_c (ft)
1	Stiff, Brownish-yellow, silty clay	284	0	1.15
2	Very stiff, Red, clayey silt			
3	PWR			
4	0			
5	0			
6	0			
7	0			

Step 4: Total Estimated Primary Consolidation Settlement for MW PZ-4 1.15 ft

MW PZ-6

Layer	Boring Log Description	From Previous Calculation				
		Soil Symbol	H_o (ft)	Increment of Vertical Effective Stress, $\Delta\sigma$ (psf)	Vertical Stress at midpoint, $\sigma_{m\ soil}$ (psf)	Vertical Stress in soil layer, $\sigma_{soil\ layers}$ (psf)
1	Very stiff, Dark reddish-gray, silty clay (above GW)	CL	7	4,910	433	865
2	Very stiff, Dark reddish-gray, silty clay (below GW)	CL	3	4,910	92	183
3	PWR	0	0	0	0	0
4	0	0	0	0	0	0
5	0	0	0	0	0	0
6	0	0	0	0	0	0
7	0	0	0	0	0	0

HDR Computation

Project: Charah Colon Mine	Computed By: TMY	Date: 10/27/2014
Subject: Permit Application	Checked By: KP	Date: 10/29/2014
Task: Settlement Calculation - Primary Consolidation Settlement	Sheet: 6	Of: 20

MW PZ-6 continued

Layer	Boring Log Description	Step 1			Step 2	Step 3
		Minimum Void Ratio, e_{min}	Maximum Void Ratio, e_{max}	Initial Void Ratio, e_{oi}	Primary Compression Index, C_c	Preconsolidation Pressure, p_c (psf)
1	Very stiff, Dark reddish-gray, silty clay (above GW)			0.44	0.10	433
2	Very stiff, Dark reddish-gray, silty clay (below GW)			0.44	0.10	958
3	PWR					
4	0					
5	0					
6	0					
7	0					

MW PZ-6 continued

Layer	Boring Log Description	Step 3, Continued	Step 4	
		Initial Vertical Effective Stress on Soil, σ_o (psf)	Recompression Index, C_r	Primary Consolidation Settlement of Clay Layer, Z_c (ft)
1	Very stiff, Dark reddish-gray, silty clay (above GW)	433	0	0.53
2	Very stiff, Dark reddish-gray, silty clay (below GW)	958	0	0.16
3	PWR			
4	0			
5	0			
6	0			
7	0			

Step 4: Total Estimated Primary Consolidation Settlement for MW PZ-6

0.69 ft

HDR Computation

Project: Charah Colon Mine	Computed By: TMY	Date: 10/27/2014
Subject: Permit Application	Checked By: KP	Date: 10/29/2014
Task: Settlement Calculation - Primary Consolidation Settlement	Sheet: 7	Of: 20

MW PZ-8

Layer	Boring Log Description	From Previous Calculation				
		Soil Symbol	H _o (ft)	Increment of Vertical Effective Stress, $\Delta\sigma$ (psf)	Vertical Stress at midpoint, $\sigma_{m\ soil}$ (psf)	Vertical Stress in soil layer, $\sigma_{soil\ layers}$ (psf)
1	Very stiff, Red, gravelly silt (above GW)	ML	7	4,407	380	760
2	Very stiff, Red, gravelly silt (below GW)	ML	2	4,407	46	92
3	PWR	0	0	0	0	0
4	0	0	0	0	0	0
5	0	0	0	0	0	0
6	0	0	0	0	0	0
7	0	0	0	0	0	0

MW PZ-8 continued

Layer	Boring Log Description	Step 1			Step 2	Step 3
		Minimum Void Ratio, e_{min}	Maximum Void Ratio, e_{max}	Initial Void Ratio, e_{oi}	Primary Compression Index, C_c	Preconsolidation Pressure, p_c (psf)
1	Very stiff, Red, gravelly silt (above GW)					
2	Very stiff, Red, gravelly silt (below GW)					
3	PWR					
4	0					
5	0					
6	0					
7	0					

HDR Computation

Project: Charah Colon Mine	Computed By: TMY	Date: 10/27/2014
Subject: Permit Application	Checked By: KP	Date: 10/29/2014
Task: Settlement Calculation - Primary Consolidation Settlement	Sheet: 8	Of: 20

MW PZ-8 continued

Layer	Boring Log Description	Step 3, Continued	Step 4	
		Initial Vertical Effective Stress on Soil, σ_o (psf)	Recompression Index, C_r	Primary Consolidation Settlement of Clay Layer, Z_c (ft)
1	Very stiff, Red, gravelly silt (above GW)			
2	Very stiff, Red, gravelly silt (below GW)			
3	PWR			
4	0			
5	0			
6	0			
7	0			

Step 4: Total Estimated Primary Consolidation Settlement for MW PZ-8 0 ft

MW PZ-9

Layer	Boring Log Description	From Previous Calculation				
		Soil Symbol	H_o (ft)	Increment of Vertical Effective Stress, $\Delta\sigma$ (psf)	Vertical Stress at midpoint, $\sigma_{m\ soil}$ (psf)	Vertical Stress in soil layer, $\sigma_{soil\ layers}$ (psf)
1	Stiff, Yellowish-brown, silty clay	CL	4	3,371	247	494
2	Compact, Weak red, clayey sand (above GW)	SC	3	3,371	173	345
3	Compact, Weak red, clayey sand (below GW)	SC	4	3,371	105	210
4	PWR	0	0	0	0	0
5	0	0	0	0	0	0
6	0	0	0	0	0	0
7	0	0	0	0	0	0

HDR Computation

Project: Charah Colon Mine	Computed By: TMY	Date: 10/27/2014
Subject: Permit Application	Checked By: KP	Date: 10/29/2014
Task: Settlement Calculation - Primary Consolidation Settlement	Sheet: 9	Of: 20

MW PZ-9 continued

Layer	Boring Log Description	Step 1			Step 2	Step 3
		Minimum Void Ratio, e_{min}	Maximum Void Ratio, e_{max}	Initial Void Ratio, e_{oi}	Primary Compression Index, C_c	Preconsolidation Pressure, p_c (psf)
1	Stiff, Yellowish-brown, silty clay			0.44	0.10	247
2	Compact, Weak red, clayey sand (above GW)					
3	Compact, Weak red, clayey sand (below GW)					
4	PWR					
5	0					
6	0					
7	0					

MW PZ-9 continued

Layer	Boring Log Description	Step 3, Continued	Step 4	
		Initial Vertical Effective Stress on Soil, σ_o (psf)	Recompression Index, C_r	Primary Consolidation Settlement of Clay Layer, Z_c (ft)
1	Stiff, Yellowish-brown, silty clay	247	0	0.32
2	Compact, Weak red, clayey sand (above GW)			
3	Compact, Weak red, clayey sand (below GW)			
4	PWR			
5	0			
6	0			
7	0			

Step 4: Total Estimated Primary Consolidation Settlement for MW PZ-9 0.32 ft

HDR Computation

Project: Charah Colon Mine	Computed By: TMY	Date: 10/27/2014
Subject: Permit Application	Checked By: KP	Date: 10/29/2014
Task: Settlement Calculation - Primary Consolidation Settlement	Sheet: 10	Of: 20

MW PZ-12

Layer	Boring Log Description	From Previous Calculation				
		Soil Symbol	H _o (ft)	Increment of Vertical Effective Stress, Δσ (psf)	Vertical Stress at midpoint, σ _{m soil} (psf)	Vertical Stress in soil layer, σ _{soil layers} (psf)
1	PWR	0	0	2,952	0	0
2	0	0	0	2,952	0	0
3	0	0	0	2,952	0	0
4	0	0	0	0	0	0
5	0	0	0	0	0	0
6	0	0	0	0	0	0
7	0	0	0	0	0	0

MW PZ-12 continued

Layer	Boring Log Description	Step 1			Step 2	Step 3
		Minimum Void Ratio, e _{min}	Maximum Void Ratio, e _{max}	Initial Void Ratio, e _{oi}	Primary Compression Index, C _c	Preconsolidation Pressure, p _c (psf)
1	PWR					
2	0					
3	0					
4	0					
5	0					
6	0					
7	0					

HDR Computation

Project: Charah Colon Mine	Computed By: TMY	Date: 10/27/2014
Subject: Permit Application	Checked By: KP	Date: 10/29/2014
Task: Settlement Calculation - Primary Consolidation Settlement	Sheet: 11	Of: 20

MW PZ-12 continued

Layer	Boring Log Description	Step 3, Continued	Step 4		
		Initial Vertical Effective Stress on Soil, σ_o (psf)	Recompression Index, C_r	Primary Consolidation Settlement of Clay Layer, Z_c (ft)	
1	PWR				
2	0				
3	0				
4	0				
5	0				
6	0				
7	0				

Step 4: Total Estimated Primary Consolidation Settlement for MW PZ-12 0 ft

MW PZ-13

Layer	Boring Log Description	From Previous Calculation				
		Soil Symbol	H_o (ft)	Increment of Vertical Effective Stress, $\Delta\sigma$ (psf)	Vertical Stress at midpoint, $\sigma_{m\ soil}$ (psf)	Vertical Stress in soil layer, $\sigma_{soil\ layers}$ (psf)
1	Stiff, Red, sandy silt	ML	6	4,030	326	651
2	Very hard, red, silty clay (below GW)	CL	15	4,030	459	917
3	PWR	0	0	0	0	0
4	0	0	0	0	0	0
5	0	0	0	0	0	0
6	0	0	0	0	0	0
7	0	0	0	0	0	0

HDR Computation

Project: Charah Colon Mine	Computed By: TMY	Date: 10/27/2014
Subject: Permit Application	Checked By: KP	Date: 10/29/2014
Task: Settlement Calculation - Primary Consolidation Settlement	Sheet: 12	Of: 20

MW PZ-13 continued

Layer	Boring Log Description	Step 1			Step 2	Step 3
		Minimum Void Ratio, e_{min}	Maximum Void Ratio, e_{max}	Initial Void Ratio, e_{oi}	Primary Compression Index, C_c	Preconsolidation Pressure, p_c (psf)
1	Stiff, Red, sandy silt					
2	Very hard, red, silty clay (below GW)			0.44	0.10	1,111
3	PWR					
4	0					
5	0					
6	0					
7	0					

MW PZ-13 continued

Layer	Boring Log Description	Step 3, Continued	Step 4	
		Initial Vertical Effective Stress on Soil, σ_o (psf)	Recompression Index, C_r	Primary Consolidation Settlement of Clay Layer, Z_c (ft)
1	Stiff, Red, sandy silt			
2	Very hard, red, silty clay (below GW)	1,111	0	0.69
3	PWR			
4	0			
5	0			
6	0			
7	0			

Step 4: Total Estimated Primary Consolidation Settlement for MW PZ-13

0.69 ft

HDR Computation

Project: Charah Colon Mine	Computed By: TMY	Date: 10/27/2014
Subject: Permit Application	Checked By: KP	Date: 10/29/2014
Task: Settlement Calculation - Primary Consolidation Settlement	Sheet: 13	Of: 20

MW PZ-15

Layer	Boring Log Description	From Previous Calculation				
		Soil Symbol	H _o (ft)	Increment of Vertical Effective Stress, $\Delta\sigma$ (psf)	Vertical Stress at midpoint, $\sigma_{m\ soil}$ (psf)	Vertical Stress in soil layer, $\sigma_{soil\ layers}$ (psf)
1	Very stiff, red, silty clay	CL	7	3,737	433	865
2	Very hard, red, silty clay (below GW)	CL	10	3,737	306	611
3	PWR	0	0	0	0	0
4	0	0	0	0	0	0
5	0	0	0	0	0	0
6	0	0	0	0	0	0
7	0	0	0	0	0	0

MW PZ-15 continued

Layer	Boring Log Description	Step 1			Step 2	Step 3
		Minimum Void Ratio, e_{min}	Maximum Void Ratio, e_{max}	Initial Void Ratio, e_{oi}	Primary Compression Index, C_c	Preconsolidation Pressure, p_c (psf)
1	Very stiff, red, silty clay			0.44	0.10	433
2	Very hard, red, silty clay (below GW)			0.44	0.10	1,172
3	PWR					
4	0					
5	0					
6	0					
7	0					

HDR Computation

Project: Charah Colon Mine	Computed By: TMY	Date: 10/27/2014
Subject: Permit Application	Checked By: KP	Date: 10/29/2014
Task: Settlement Calculation - Primary Consolidation Settlement	Sheet: 14	Of: 20

MW PZ-15 continued

Layer	Boring Log Description	Step 3, Continued	Step 4		
		Initial Vertical Effective Stress on Soil, σ_o (psf)	Recompression Index, C_r	Primary Consolidation Settlement of Clay Layer, Z_c (ft)	
1	Very stiff, red, silty clay	433	0	0.48	
2	Very hard, red, silty clay (below GW)	1,172	0	0.43	
3	PWR				
4	0				
5	0				
6	0				
7	0				

Step 4: Total Estimated Primary Consolidation Settlement for MW PZ-15 0.91 ft

MW PZ-16

Layer	Boring Log Description	From Previous Calculation				
		Soil Symbol	H_o (ft)	Increment of Vertical Effective Stress, $\Delta\sigma$ (psf)	Vertical Stress at midpoint, $\sigma_{m\ soil}$ (psf)	Vertical Stress in soil layer, $\sigma_{soil\ layers}$ (psf)
1	Stiff, Strong brown, clayey silt	MH	2	4,213	109	217
2	Stiff, Yellowish-red, silty clay (above GW)	CL	6	4,213	371	741
3	Very hard, Red, silty clay (below GW)	CL	12	4,213	367	733
4	PWR	0	0	0	0	0
5	0	0	0	0	0	0
6	0	0	0	0	0	0
7	0	0	0	0	0	0

HDR Computation

Project: Charah Colon Mine	Computed By: TMY	Date: 10/27/2014
Subject: Permit Application	Checked By: KP	Date: 10/29/2014
Task: Settlement Calculation - Primary Consolidation Settlement	Sheet: 15	Of: 20

MW PZ-16 continued

Layer	Boring Log Description	Step 1			Step 2	Step 3
		Minimum Void Ratio, e_{min}	Maximum Void Ratio, e_{max}	Initial Void Ratio, e_{oi}	Primary Compression Index, C_c	Preconsolidation Pressure, p_c (psf)
1	Stiff, Strong brown, clayey silt					109
2	Stiff, Yellowish-red, silty clay (above GW)			0.44	0.10	589
3	Very hard, Red, silty clay (below GW)			0.44	0.10	1,327
4	PWR					
5	0					
6	0					
7	0					

MW PZ-16 continued

Layer	Boring Log Description	Step 3, Continued	Step 4	
		Initial Vertical Effective Stress on Soil, σ_o (psf)	Recompression Index, C_r	Primary Consolidation Settlement of Clay Layer, Z_c (ft)
1	Stiff, Strong brown, clayey silt	109	0	0.00
2	Stiff, Yellowish-red, silty clay (above GW)	589	0	0.38
3	Very hard, Red, silty clay (below GW)	1,327	0	0.52
4	PWR			
5	0			
6	0			
7	0			

Step 4: Total Estimated Primary Consolidation Settlement for MW PZ-16

0.9 ft

HDR Computation

Project: Charah Colon Mine	Computed By: TMY	Date: 10/27/2014
Subject: Permit Application	Checked By: KP	Date: 10/29/2014
Task: Settlement Calculation - Primary Consolidation Settlement	Sheet: 16	Of: 20

MW PZ-18

Layer	Boring Log Description	From Previous Calculation				
		Soil Symbol	H _o (ft)	Increment of Vertical Effective Stress, $\Delta\sigma$ (psf)	Vertical Stress at midpoint, $\sigma_{m\ soil}$ (psf)	Vertical Stress in soil layer, $\sigma_{soil\ layers}$ (psf)
1	Very stiff, Red, silty clay	CL	2	4,282	124	247
2	Hard, Red, clayey silt	MH	5	4,282	272	543
3	PWR	0	0	0	0	0
4	0	0	0	0	0	0
5	0	0	0	0	0	0
6	0	0	0	0	0	0
7	0	0	0	0	0	0

MW PZ-18 continued

Layer	Boring Log Description	Step 1			Step 2	Step 3
		Minimum Void Ratio, e_{min}	Maximum Void Ratio, e_{max}	Initial Void Ratio, e_{oi}	Primary Compression Index, C_c	Preconsolidation Pressure, p_c (psf)
1	Very stiff, Red, silty clay			0.44	0.10	124
2	Hard, Red, clayey silt					
3	PWR					
4	0					
5	0					
6	0					
7	0					

HDR Computation

Project: Charah Colon Mine	Computed By: TMY	Date: 10/27/2014
Subject: Permit Application	Checked By: KP	Date: 10/29/2014
Task: Settlement Calculation - Primary Consolidation Settlement	Sheet: 17	Of: 20

MW PZ-18 continued

Layer	Boring Log Description	Step 3, Continued	Step 4		
		Initial Vertical Effective Stress on Soil, σ_o (psf)	Recompression Index, C_r	Primary Consolidation Settlement of Clay Layer, Z_c (ft)	
1	Very stiff, Red, silty clay	124	0	0.22	
2	Hard, Red, clayey silt				
3	PWR				
4	0				
5	0				
6	0				
7	0				

Step 4: Total Estimated Primary Consolidation Settlement for MW PZ-18 0.22 ft

MW PZ-19

Layer	Boring Log Description	From Previous Calculation				
		Soil Symbol	H_o (ft)	Increment of Vertical Effective Stress, $\Delta\sigma$ (psf)	Vertical Stress at midpoint, $\sigma_{m\ soil}$ (psf)	Vertical Stress in soil layer, $\sigma_{soil\ layers}$ (psf)
1	Medium, Light brownish-gray, silty clay	CL	5	5,855	309	618
2	Hard, Yellowish-brown, clayey silt (below GW)	MH	10	5,855	231	461
3	PWR	0	0	0	0	0
4	0	0	0	0	0	0
5	0	0	0	0	0	0
6	0	0	0	0	0	0
7	0	0	0	0	0	0

HDR Computation

Project: Charah Colon Mine	Computed By: TMY	Date: 10/27/2014
Subject: Permit Application	Checked By: KP	Date: 10/29/2014
Task: Settlement Calculation - Primary Consolidation Settlement	Sheet: 18	Of: 20

MW PZ-19 continued

Layer	Boring Log Description	Step 1			Step 2	Step 3
		Minimum Void Ratio, e_{min}	Maximum Void Ratio, e_{max}	Initial Void Ratio, e_{oi}	Primary Compression Index, C_c	Preconsolidation Pressure, p_c (psf)
1	Medium, Light brownish-gray, silty clay			0.44	0.10	309
2	Hard, Yellowish-brown, clayey silt (below GW)					
3	PWR					
4	0					
5	0					
6	0					
7	0					

MW PZ-19 continued

Layer	Boring Log Description	Step 3, Continued	Step 4	
		Initial Vertical Effective Stress on Soil, σ_o (psf)	Recompression Index, C_r	Primary Consolidation Settlement of Clay Layer, Z_c (ft)
1	Medium, Light brownish-gray, silty clay	309	0	0.45
2	Hard, Yellowish-brown, clayey silt (below GW)			
3	PWR			
4	0			
5	0			
6	0			
7	0			

Step 4: Total Estimated Primary Consolidation Settlement for MW PZ-19

0.45 ft

HDR Computation

Project: Charah Colon Mine	Computed By: TMY	Date: 10/27/2014
Subject: Permit Application	Checked By: KP	Date: 10/29/2014
Task: Settlement Calculation - Primary Consolidation Settlement	Sheet: 19	Of: 20

MW PZ-20

Layer	Boring Log Description	From Previous Calculation				
		Soil Symbol	H _o (ft)	Increment of Vertical Effective Stress, $\Delta\sigma$ (psf)	Vertical Stress at midpoint, $\sigma_{m\ soil}$ (psf)	Vertical Stress in soil layer, $\sigma_{soil\ layers}$ (psf)
1	Stiff, Red, sandy silty clay (above GW)	CL	10	3,108	618	1,235
2	Stiff, Red, sandy silty clay (below GW)	CL	8	3,108	245	489
3	PWR	0	0	0	0	0
4	0	0	0	0	0	0
5	0	0	0	0	0	0
6	0	0	0	0	0	0
7	0	0	0	0	0	0

MW PZ-20 continued

Layer	Boring Log Description	Step 1			Step 2	Step 3
		Minimum Void Ratio, e_{min}	Maximum Void Ratio, e_{max}	Initial Void Ratio, e_{oi}	Primary Compression Index, C_c	Preconsolidation Pressure, p_c (psf)
1	Stiff, Red, sandy silty clay (above GW)			0.44	0.10	618
2	Stiff, Red, sandy silty clay (below GW)			0.44	0.10	1,481
3	PWR					
4	0					
5	0					
6	0					
7	0					

HDR Computation

Project: Charah Colon Mine	Computed By: TMY	Date: 10/27/2014
Subject: Permit Application	Checked By: KP	Date: 10/29/2014
Task: Settlement Calculation - Primary Consolidation Settlement	Sheet: 20	Of: 20

MW PZ-20 continued

Layer	Boring Log Description	Step 3, Continued	Step 4	
		Initial Vertical Effective Stress on Soil, σ_o (psf)	Recompression Index, C_r	Primary Consolidation Settlement of Clay Layer, Z_c (ft)
1	Stiff, Red, sandy silty clay (above GW)	618	0	0.54
2	Stiff, Red, sandy silty clay (below GW)	1,481	0	0.27
3	PWR			
4	0			
5	0			
6	0			
7	0			

Step 4: Total Estimated Primary Consolidation Settlement for MW PZ-20

0.81 ft

HDR Computation

Project: Charah Colon Mine	Computed By: TMY	Date: 10/27/2014
Subject: Permit Application	Checked By: KP	Date: 10/29/2014
Task: Settlement Calculation - Secondary Compression Settlement	Sheet: 1	Of: 19

Steps - Secondary Consolidation (Clay Soils)

1. Estimate the water content (w_n) using the equation below and Table 6 (page 7.1-22) of Reference 1 (Attachment E). Estimate the secondary consolidation compression index (C_α) using Figure 16 (page 7.1-237) of Reference 1 (Attachment G) and the estimated water content (w_n).

$$w_n = \frac{\gamma_{wet} - \gamma_{dry}}{\gamma_{dry}}$$

2. Estimate the initial thickness of the clay layer before starting secondary consolidation settlement (H_{os}) using the initial layer thickness (H_o), the elastic settlement (Z_e), the primary consolidation settlement (Z_c) and the equation below.

$$H_{os} = H_o - Z_e - Z_c$$

3. Determine the secondary compression using the Equation 12.23 (page 470) below from Reference 3. Assume the initial void ratio of the clay layer before secondary consolidation settlement is equal to the minimum void ratio in Table 6 (page 7.1-22) of Reference 1 (Attachment E).

$$Z_\alpha = C_\alpha \times \frac{H_{os}}{1 + e_{os}} \times \log \frac{t_2}{t_1}$$

Where:

Z_α = long-term secondary compression (ft)

e_{os} = initial void ratio of clay layer before starting secondary consolidation settlement

C_α = secondary consolidation compression index

H_{os} = initial thickness of clay layer before starting secondary consolidation settlement (ft)

t_1 = starting time of the time period for which long-term settlement of the layer is desired

t_2 = ending time of the time period for which long-term settlement of the layer is desired

assume $t_1 = 1$ year

assume $t_2 = 100$ years

HDR Computation

Project: Charah Colon Mine	Computed By: TMY	Date: 10/27/2014
Subject: Permit Application	Checked By: KP	Date: 10/29/2014
Task: Settlement Calculation - Secondary Compression Settlement	Sheet: 2	Of: 19

4. Repeat Steps 1 - 3 for each clay layer. Add the secondary compression settlement for each clay layer together to get the total estimated secondary compression settlement at that location based on information from the boring logs, recent surveys, and seasonal high groundwater levels.

$$Z_{\alpha Total} = Z_{\alpha layer n} + Z_{\alpha layer n+1}$$

Calculations

MW PZ-3

Layer	Boring Log Description	From Previous Calculations				Step 1
		Initial Layer Thickness, H_o (ft)	Elastic Layer Settlement, Z_e (ft)	Primary Consolidation Settlement of Clay, Z_c (ft)	Wet Unit Weight, γ_{wet} (pcf)	Minimum dry unit weight, $\gamma_{dry min}$ (pcf)
1	Hard, Reddish-brown, clayey silt	3	0.07	0.00	109	
2	PWR	0	0.00	0.00	0	
3	0	0	0.00	0.00	0	
4	0	0	0.00	0.00	0	
5	0	0	0.00	0.00	0	
6	0	0	0.00	0.00	0	
7	0	0	0.00	0.00	0	

MW PZ-3 continued

Layer	Boring Log Description	Step 1, continued			Step 2
		Maximum dry unit weight, $\gamma_{dry max}$ (pcf)	Average dry unit weight, $\gamma_{dry avg}$ (pcf)	water content, w_n	Secondary Consolidation Compression Index, C_{α}
1	Hard, Reddish-brown, clayey silt				
2	PWR				
3	0				
4	0				
5	0				
6	0				
7	0				

HDR Computation

Project: Charah Colon Mine	Computed By: TMY	Date: 10/27/2014
Subject: Permit Application	Checked By: KP	Date: 10/29/2014
Task: Settlement Calculation - Secondary Compression Settlement	Sheet: 3	Of: 19

MW PZ-3 continued

Layer	Boring Log Description	Step 3	
		Initial Void Ratio of Clay before Secondary Settlement, e_{os}	Secondary Compression Settlement of Clay Layer, Z_{α} (ft)
1	Hard, Reddish-brown, clayey silt		
2	PWR		
3	0		
4	0		
5	0		
6	0		
7	0		

Step 4: Total Estimated Secondary Compression Settlement for MW PZ-3 0 ft

MW PZ-4

Layer	Boring Log Description	From Previous Calculations				Step 1
		Initial Layer Thickness, H_o (ft)	Elastic Layer Settlement, Z_e (ft)	Primary Consolidation Settlement of Clay, Z_c (ft)	Wet Unit Weight, γ_{wet} (pcf)	Minimum dry unit weight, $\gamma_{dry\ min}$ (pcf)
1	Stiff, Brownish-yellow, silty clay	5	0.11	1.15	114	50
2	Very stiff, Red, clayey silt	7	0.12	0.00	109	
3	PWR	0	0.00	0.00	0	
4	0	0	0.00	0.00	0	
5	0	0	0.00	0.00	0	
6	0	0	0.00	0.00	0	
7	0	0	0.00	0.00	0	

HDR Computation

Project: Charah Colon Mine	Computed By: TMY	Date: 10/27/2014
Subject: Permit Application	Checked By: KP	Date: 10/29/2014
Task: Settlement Calculation - Secondary Compression Settlement	Sheet: 4	Of: 19

MW PZ-4 continued

Layer	Boring Log Description	Step 1, continued			Secondary Consolidation Compression Index, C_{α}	Step 2 Initial Thickness of Clay Layer before Secondary Settlement, H_{os} (ft)
		Maximum dry unit weight, $\gamma_{dry\ max}$ (pcf)	Average dry unit weight, $\gamma_{dry\ avg}$ (pcf)	water content, w_n		
1	Stiff, Brownish-yellow, silty clay	112	81	0.40	0.004	3.74
2	Very stiff, Red, clayey silt					
3	PWR					
4	0					
5	0					
6	0					
7	0					

MW PZ-4 continued

Layer	Boring Log Description	Step 3	
		Initial Void Ratio of Clay before Secondary Settlement, e_{os}	Secondary Compression Settlement of Clay Layer, Z_{α} (ft)
1	Stiff, Brownish-yellow, silty clay	0.50	0.02
2	Very stiff, Red, clayey silt		
3	PWR		
4	0		
5	0		
6	0		
7	0		

Step 4: Total Estimated Secondary Compression Settlement for MW PZ-4 0.02 ft

HDR Computation

Project: Charah Colon Mine	Computed By: TMY	Date: 10/27/2014
Subject: Permit Application	Checked By: KP	Date: 10/29/2014
Task: Settlement Calculation - Secondary Compression Settlement	Sheet: 5	Of: 19

MW PZ-6

Layer	Boring Log Description	From Previous Calculations				Step 1
		Initial Layer Thickness, H_o (ft)	Elastic Layer Settlement, Z_e (ft)	Primary Consolidation Settlement of Clay, Z_c (ft)	Wet Unit Weight, γ_{wet} (pcf)	Minimum dry unit weight, $\gamma_{dry\ min}$ (pcf)
1	Very stiff, Dark reddish-gray, silty clay (above GW)	7	0.19	0.53	124	60
2	Very stiff, Dark reddish-gray, silty clay (below GW)	3	0.06	0.16	124	60
3	PWR	0	0.00	0.00	0	
4	0	0	0.00	0.00	0	
5	0	0	0.00	0.00	0	
6	0	0	0.00	0.00	0	
7	0	0	0.00	0.00	0	

MW PZ-6 continued

Layer	Boring Log Description	Step 1, continued				Step 2
		Maximum dry unit weight, $\gamma_{dry\ max}$ (pcf)	Average dry unit weight, $\gamma_{dry\ avg}$ (pcf)	water content, w_n	Secondary Consolidation Compression Index, C_α	Initial Thickness of Clay Layer before Secondary Settlement, H_{os} (ft)
1	Very stiff, Dark reddish-gray, silty clay (above GW)	135	98	0.30	0.003	6.28
2	Very stiff, Dark reddish-gray, silty clay (below GW)	135	98	0.30	0.003	2.78
3	PWR					
4	0					
5	0					
6	0					
7	0					

HDR Computation

Project: Charah Colon Mine	Computed By: TMY	Date: 10/27/2014
Subject: Permit Application	Checked By: KP	Date: 10/29/2014
Task: Settlement Calculation - Secondary Compression Settlement	Sheet: 6	Of: 19

MW PZ-6 continued

Layer	Boring Log Description	Step 3	
		Initial Void Ratio of Clay before Secondary Settlement, e_{os}	Secondary Compression Settlement of Clay Layer, Z_s (ft)
1	Very stiff, Dark reddish-gray, silty clay (above GW)	0.25	0.03
2	Very stiff, Dark reddish-gray, silty clay (below GW)	0.25	0.01
3	PWR		
4	0		
5	0		
6	0		
7	0		

Step 4: Total Estimated Secondary Compression Settlement for MW PZ-6 0.04 ft

MW PZ-8

Layer	Boring Log Description	From Previous Calculations				Step 1
		Initial Layer Thickness, H_o (ft)	Elastic Layer Settlement, Z_e (ft)	Primary Consolidation Settlement of Clay, Z_c (ft)	Wet Unit Weight, γ_{wet} (pcf)	Minimum dry unit weight, $\gamma_{dry\ min}$ (pcf)
1	Very stiff, Red, gravelly silt (above GW)	7	0.07	0.00	109	
2	Very stiff, Red, gravelly silt (below GW)	2	0.02	0.00	109	
3	PWR	0	0.00	0.00	0	
4	0	0	0.00	0.00	0	
5	0	0	0.00	0.00	0	
6	0	0	0.00	0.00	0	
7	0	0	0.00	0.00	0	

HDR Computation

Project: Charah Colon Mine	Computed By: TMY	Date: 10/27/2014
Subject: Permit Application	Checked By: KP	Date: 10/29/2014
Task: Settlement Calculation - Secondary Compression Settlement	Sheet: 7	Of: 19

MW PZ-8 continued

Layer	Boring Log Description	Step 1, continued			Secondary Consolidation Compression Index, C_{α}	Step 2 Initial Thickness of Clay Layer before Secondary Settlement, H_{os} (ft)
		Maximum dry unit weight, $\gamma_{dry\ max}$ (pcf)	Average dry unit weight, $\gamma_{dry\ avg}$ (pcf)	water content, w_n		
1	Very stiff, Red, gravelly silt (above GW)					
2	Very stiff, Red, gravelly silt (below GW)					
3	PWR					
4	0					
5	0					
6	0					
7	0					

MW PZ-8 continued

Layer	Boring Log Description	Step 3	
		Initial Void Ratio of Clay before Secondary Settlement, e_{os}	Secondary Compression Settlement of Clay Layer, Z_{α} (ft)
1	Very stiff, Red, gravelly silt (above GW)		0.00
2	Very stiff, Red, gravelly silt (below GW)		0.00
3	PWR		
4	0		
5	0		
6	0		
7	0		

Step 4: Total Estimated Secondary Compression Settlement for MW PZ-8 0 ft

HDR Computation

Project: Charah Colon Mine	Computed By: TMY	Date: 10/27/2014
Subject: Permit Application	Checked By: KP	Date: 10/29/2014
Task: Settlement Calculation - Secondary Compression Settlement	Sheet: 8	Of: 19

MW PZ-9

Layer	Boring Log Description	From Previous Calculations				Step 1
		Initial Layer Thickness, H_o (ft)	Elastic Layer Settlement, Z_e (ft)	Primary Consolidation Settlement of Clay, Z_c (ft)	Wet Unit Weight, γ_{wet} (pcf)	Minimum dry unit weight, $\gamma_{dry\ min}$ (pcf)
1	Stiff, Yellowish-brown, silty clay	4	0.09	0.32	124	60
2	Compact, Weak red, clayey sand (above GW)	3	0.05	0.00	115	
3	Compact, Weak red, clayey sand (below GW)	4	0.07	0.00	115	
4	PWR	0	0.00	0.00	0	
5	0	0	0.00	0.00	0	
6	0	0	0.00	0.00	0	
7	0	0	0.00	0.00	0	

MW PZ-9 continued

Layer	Boring Log Description	Step 1, continued			Step 2
		Maximum dry unit weight, $\gamma_{dry\ max}$ (pcf)	Average dry unit weight, $\gamma_{dry\ avg}$ (pcf)	water content, w_n	Secondary Consolidation Compression Index, C_α
1	Stiff, Yellowish-brown, silty clay	135	98	0.30	0.003
2	Compact, Weak red, clayey sand (above GW)				
3	Compact, Weak red, clayey sand (below GW)				
4	PWR				
5	0				
6	0				
7	0				

HDR Computation

Project: Charah Colon Mine	Computed By: TMY	Date: 10/27/2014
Subject: Permit Application	Checked By: KP	Date: 10/29/2014
Task: Settlement Calculation - Secondary Compression Settlement	Sheet: 9	Of: 19

MW PZ-9 continued

Layer	Boring Log Description	Step 3	
		Initial Void Ratio of Clay before Secondary Settlement, e_{os}	Secondary Compression Settlement of Clay Layer, Z_{α} (ft)
1	Stiff, Yellowish-brown, silty clay	0.25	0.02
2	Compact, Weak red, clayey sand (above GW)		
3	Compact, Weak red, clayey sand (below GW)		
4	PWR		
5	0		
6	0		
7	0		

Step 4: Total Estimated Secondary Compression Settlement for MW PZ-9 0.02 ft

MW PZ-12

Layer	Boring Log Description	From Previous Calculations				Step 1
		Initial Layer Thickness, H_o (ft)	Elastic Layer Settlement, Z_e (ft)	Primary Consolidation Settlement of Clay, Z_c (ft)	Wet Unit Weight, γ_{wet} (pcf)	Minimum dry unit weight, $\gamma_{dry\ min}$ (pcf)
1	PWR	0	0.00	0.00	0	
2	0	0	0.00	0.00	0	
3	0	0	0.00	0.00	0	
4	0	0	0.00	0.00	0	
5	0	0	0.00	0.00	0	
6	0	0	0.00	0.00	0	
7	0	0	0.00	0.00	0	

HDR Computation

Project: Charah Colon Mine	Computed By: TMY	Date: 10/27/2014
Subject: Permit Application	Checked By: KP	Date: 10/29/2014
Task: Settlement Calculation - Secondary Compression Settlement	Sheet: 10	Of: 19

MW PZ-12 continued

Layer	Boring Log Description	Step 1, continued			Secondary Consolidation Compression Index, C_{α}	Step 2 Initial Thickness of Clay Layer before Secondary Settlement, H_{os} (ft)
		Maximum dry unit weight, $\gamma_{dry\ max}$ (pcf)	Average dry unit weight, $\gamma_{dry\ avg}$ (pcf)	water content, w_n		
1	PWR					
2	0					
3	0					
4	0					
5	0					
6	0					
7	0					

MW PZ-12 continued

Layer	Boring Log Description	Step 3	
		Initial Void Ratio of Clay before Secondary Settlement, e_{os}	Secondary Compression Settlement of Clay Layer, Z_{α} (ft)
1	PWR		
2	0		
3	0		
4	0		
5	0		
6	0		
7	0		

Step 4: Total Estimated Secondary Compression Settlement for MW PZ-12 0 ft

HDR Computation

Project: Charah Colon Mine	Computed By: TMY	Date: 10/27/2014
Subject: Permit Application	Checked By: KP	Date: 10/29/2014
Task: Settlement Calculation - Secondary Compression Settlement	Sheet: 11	Of: 19

MW PZ-13

Layer	Boring Log Description	From Previous Calculations				Step 1
		Initial Layer Thickness, H_o (ft)	Elastic Layer Settlement, Z_e (ft)	Primary Consolidation Settlement of Clay, Z_c (ft)	Wet Unit Weight, γ_{wet} (pcf)	Minimum dry unit weight, $\gamma_{dry\ min}$ (pcf)
1	Stiff, Red, sandy silt	6	0.06	0.00	109	
2	Very hard, red, silty clay (below GW)	15	0.27	0.69	124	60
3	PWR	0	0.00	0.00	0	
4	0	0	0.00	0.00	0	
5	0	0	0.00	0.00	0	
6	0	0	0.00	0.00	0	
7	0	0	0.00	0.00	0	

MW PZ-13 continued

Layer	Boring Log Description	Step 1, continued			Step 2
		Maximum dry unit weight, $\gamma_{dry\ max}$ (pcf)	Average dry unit weight, $\gamma_{dry\ avg}$ (pcf)	water content, w_n	Secondary Consolidation Compression Index, C_α
1	Stiff, Red, sandy silt				
2	Very hard, red, silty clay (below GW)	135	98	0.30	0.003
3	PWR				
4	0				
5	0				
6	0				
7	0				

HDR Computation

Project: Charah Colon Mine	Computed By: TMY	Date: 10/27/2014
Subject: Permit Application	Checked By: KP	Date: 10/29/2014
Task: Settlement Calculation - Secondary Compression Settlement	Sheet: 12	Of: 19

MW PZ-13 continued

Layer	Boring Log Description	Step 3	
		Initial Void Ratio of Clay before Secondary Settlement, e_{os}	Secondary Compression Settlement of Clay Layer, Z_c (ft)
1	Stiff, Red, sandy silt		
2	Very hard, red, silty clay (below GW)	0.25	0.07
3	PWR		
4	0		
5	0		
6	0		
7	0		

Step 4: Total Estimated Secondary Compression Settlement for MW PZ-13 0.07 ft

MW PZ-15

Layer	Boring Log Description	From Previous Calculations				Step 1
		Initial Layer Thickness, H_o (ft)	Elastic Layer Settlement, Z_e (ft)	Primary Consolidation Settlement of Clay, Z_c (ft)	Wet Unit Weight, γ_{wet} (pcf)	Minimum dry unit weight, $\gamma_{dry\ min}$ (pcf)
1	Very stiff, red, silty clay	7	0.14	0.48	124	60
2	Very hard, red, silty clay (below GW)	10	0.16	0.43	124	60
3	PWR	0	0.00	0.00	0	
4	0	0	0.00	0.00	0	
5	0	0	0.00	0.00	0	
6	0	0	0.00	0.00	0	
7	0	0	0.00	0.00	0	

HDR Computation

Project: Charah Colon Mine	Computed By: TMY	Date: 10/27/2014
Subject: Permit Application	Checked By: KP	Date: 10/29/2014
Task: Settlement Calculation - Secondary Compression Settlement	Sheet: 13	Of: 19

MW PZ-15 continued

Layer	Boring Log Description	Step 1, continued			Step 2
		Maximum dry unit weight, $\gamma_{dry\ max}$ (pcf)	Average dry unit weight, $\gamma_{dry\ avg}$ (pcf)	water content, w_n	Secondary Consolidation Compression Index, C_α
1	Very stiff, red, silty clay	135	98	0.30	0.003
2	Very hard, red, silty clay (below GW)	135	98	0.30	0.003
3	PWR				
4	0				
5	0				
6	0				
7	0				

MW PZ-15 continued

Layer	Boring Log Description	Step 3	
		Initial Void Ratio of Clay before Secondary Settlement, e_{os}	Secondary Compression Settlement of Clay Layer, Z_α (ft)
1	Very stiff, red, silty clay	0.25	0.03
2	Very hard, red, silty clay (below GW)	0.25	0.05
3	PWR		
4	0		
5	0		
6	0		
7	0		

Step 4: Total Estimated Secondary Compression Settlement for MW PZ-15 0.08 ft

HDR Computation

Project: Charah Colon Mine	Computed By: TMY	Date: 10/27/2014
Subject: Permit Application	Checked By: KP	Date: 10/29/2014
Task: Settlement Calculation - Secondary Compression Settlement	Sheet: 14	Of: 19

MW PZ-16

Layer	Boring Log Description	From Previous Calculations				Step 1
		Initial Layer Thickness, H_o (ft)	Elastic Layer Settlement, Z_e (ft)	Primary Consolidation Settlement of Clay, Z_c (ft)	Wet Unit Weight, γ_{wet} (pcf)	Minimum dry unit weight, $\gamma_{dry\ min}$ (pcf)
1	Stiff, Strong brown, clayey silt	2	0.06	0.00	109	
2	Stiff, Yellowish-red, silty clay (above GW)	6	0.14	0.38	124	60
3	Very hard, Red, silty clay (below GW)	12	0.22	0.52	124	60
4	PWR	0	0.00	0.00	0	
5	0	0	0.00	0.00	0	
6	0	0	0.00	0.00	0	
7	0	0	0.00	0.00	0	

MW PZ-16 continued

Layer	Boring Log Description	Step 1, continued				Step 2
		Maximum dry unit weight, $\gamma_{dry\ max}$ (pcf)	Average dry unit weight, $\gamma_{dry\ avg}$ (pcf)	water content, w_n	Secondary Consolidation Compression Index, C_α	Initial Thickness of Clay Layer before Secondary Settlement, H_{os} (ft)
1	Stiff, Strong brown, clayey silt					
2	Stiff, Yellowish-red, silty clay (above GW)	135	98	0.30	0.003	5.48
3	Very hard, Red, silty clay (below GW)	135	98	0.30	0.003	11.26
4	PWR					
5	0					
6	0					
7	0					

HDR Computation

Project: Charah Colon Mine	Computed By: TMY	Date: 10/27/2014
Subject: Permit Application	Checked By: KP	Date: 10/29/2014
Task: Settlement Calculation - Secondary Compression Settlement	Sheet: 15	Of: 19

MW PZ-16 continued

Layer	Boring Log Description	Step 3	
		Initial Void Ratio of Clay before Secondary Settlement, e_{os}	Secondary Compression Settlement of Clay Layer, Z_α (ft)
1	Stiff, Strong brown, clayey silt		
2	Stiff, Yellowish-red, silty clay (above GW)	0.25	0.03
3	Very hard, Red, silty clay (below GW)	0.25	0.05
4	PWR		
5	0		
6	0		
7	0		

Step 4: Total Estimated Secondary Compression Settlement for MW PZ-16 0.08 ft

MW PZ-18

Layer	Boring Log Description	From Previous Calculations				Step 1
		Initial Layer Thickness, H_o (ft)	Elastic Layer Settlement, Z_e (ft)	Primary Consolidation Settlement of Clay, Z_c (ft)	Wet Unit Weight, γ_{wet} (pcf)	Minimum dry unit weight, $\gamma_{dry\ min}$ (pcf)
1	Very stiff, Red, silty clay	2	0.06	0.22	124	60
2	Hard, Red, clayey silt	5	0.12	0.00	109	
3	PWR	0	0.00	0.00	0	
4	0	0	0.00	0.00	0	
5	0	0	0.00	0.00	0	
6	0	0	0.00	0.00	0	
7	0	0	0.00	0.00	0	

HDR Computation

Project: Charah Colon Mine	Computed By: TMY	Date: 10/27/2014
Subject: Permit Application	Checked By: KP	Date: 10/29/2014
Task: Settlement Calculation - Secondary Compression Settlement	Sheet: 16	Of: 19

MW PZ-18 continued

Layer	Boring Log Description	Step 1, continued			Secondary Consolidation Compression Index, C_α	Step 2 Initial Thickness of Clay Layer before Secondary Settlement, H_{os} (ft)
		Maximum dry unit weight, $\gamma_{dry\ max}$ (pcf)	Average dry unit weight, $\gamma_{dry\ avg}$ (pcf)	water content, w_n		
1	Very stiff, Red, silty clay	135	98	0.30	0.003	1.72
2	Hard, Red, clayey silt					
3	PWR					
4	0					
5	0					
6	0					
7	0					

MW PZ-18 continued

Layer	Boring Log Description	Step 3	
		Initial Void Ratio of Clay before Secondary Settlement, e_{os}	Secondary Compression Settlement of Clay Layer, Z_α (ft)
1	Very stiff, Red, silty clay	0.25	0.01
2	Hard, Red, clayey silt		
3	PWR		
4	0		
5	0		
6	0		
7	0		

Step 4: Total Estimated Secondary Compression Settlement for MW PZ-18 0.01 ft

HDR Computation

Project: Charah Colon Mine	Computed By: TMY	Date: 10/27/2014
Subject: Permit Application	Checked By: KP	Date: 10/29/2014
Task: Settlement Calculation - Secondary Compression Settlement	Sheet: 17	Of: 19

MW PZ-19

Layer	Boring Log Description	From Previous Calculations				Step 1
		Initial Layer Thickness, H_o (ft)	Elastic Layer Settlement, Z_e (ft)	Primary Consolidation Settlement of Clay, Z_c (ft)	Wet Unit Weight, γ_{wet} (pcf)	Minimum dry unit weight, $\gamma_{dry\ min}$ (pcf)
1	Medium, Light brownish-gray, silty clay	5	1.37	0.45	124	60
2	Hard, Yellowish-brown, clayey silt (below GW)	10	0.32	0.00	109	
3	PWR	0	0.00	0.00	0	
4	0	0	0.00	0.00	0	
5	0	0	0.00	0.00	0	
6	0	0	0.00	0.00	0	
7	0	0	0.00	0.00	0	

MW PZ-19 continued

Layer	Boring Log Description	Step 1, continued				Step 2
		Maximum dry unit weight, $\gamma_{dry\ max}$ (pcf)	Average dry unit weight, $\gamma_{dry\ avg}$ (pcf)	water content, w_n	Secondary Consolidation Compression Index, C_α	Initial Thickness of Clay Layer before Secondary Settlement, H_{os} (ft)
1	Medium, Light brownish-gray, silty clay	135	98	0.30	0.003	3.18
2	Hard, Yellowish-brown, clayey silt (below GW)					
3	PWR					
4	0					
5	0					
6	0					
7	0					

HDR Computation

Project: Charah Colon Mine	Computed By: TMY	Date: 10/27/2014
Subject: Permit Application	Checked By: KP	Date: 10/29/2014
Task: Settlement Calculation - Secondary Compression Settlement	Sheet: 18	Of: 19

MW PZ-19 continued

Layer	Boring Log Description	Step 3	
		Initial Void Ratio of Clay before Secondary Settlement, e_{os}	Secondary Compression Settlement of Clay Layer, Z_{α} (ft)
1	Medium, Light brownish-gray, silty clay	0.25	0.02
2	Hard, Yellowish-brown, clayey silt (below GW)		
3	PWR		
4	0		
5	0		
6	0		
7	0		

Step 4: Total Estimated Secondary Compression Settlement for MW PZ-19 0.02 ft

MW PZ-20

Layer	Boring Log Description	From Previous Calculations				Step 1
		Initial Layer Thickness, H_o (ft)	Elastic Layer Settlement, Z_e (ft)	Primary Consolidation Settlement of Clay, Z_c (ft)	Wet Unit Weight, γ_{wet} (pcf)	Minimum dry unit weight, $\gamma_{dry\ min}$ (pcf)
1	Stiff, Red, sandy silty clay (above GW)	10	0.17	0.54	124	60
2	Stiff, Red, sandy silty clay (below GW)	8	0.11	0.27	124	60
3	PWR	0	0.00	0.00	0	
4	0	0	0.00	0.00	0	
5	0	0	0.00	0.00	0	
6	0	0	0.00	0.00	0	
7	0	0	0.00	0.00	0	

HDR Computation

Project: Charah Colon Mine	Computed By: TMY	Date: 10/27/2014
Subject: Permit Application	Checked By: KP	Date: 10/29/2014
Task: Settlement Calculation - Secondary Compression Settlement	Sheet: 19	Of: 19

MW PZ-20 continued

Layer	Boring Log Description	Step 1, continued			Step 2	
		Maximum dry unit weight, $\gamma_{dry\ max}$ (pcf)	Average dry unit weight, $\gamma_{dry\ avg}$ (pcf)	water content, w_n	Secondary Consolidation Compression Index, C_α	Initial Thickness of Clay Layer before Secondary Settlement, H_{os} (ft)
1	Stiff, Red, sandy silty clay (above GW)	135	98	0.30	0.003	9.29
2	Stiff, Red, sandy silty clay (below GW)	135	98	0.30	0.003	7.62
3	PWR					
4	0					
5	0					
6	0					
7	0					

MW PZ-20 continued

Layer	Boring Log Description	Step 3	
		Initial Void Ratio of Clay before Secondary Settlement, e_{os}	Secondary Compression Settlement of Clay Layer, Z_α (ft)
1	Stiff, Red, sandy silty clay (above GW)	0.25	0.04
2	Stiff, Red, sandy silty clay (below GW)	0.25	0.04
3	PWR		
4	0		
5	0		
6	0		
7	0		

Step 4: Total Estimated Secondary Compression Settlement for MW PZ-20 0.08 ft

This page intentionally left blank.

FIGURE 1

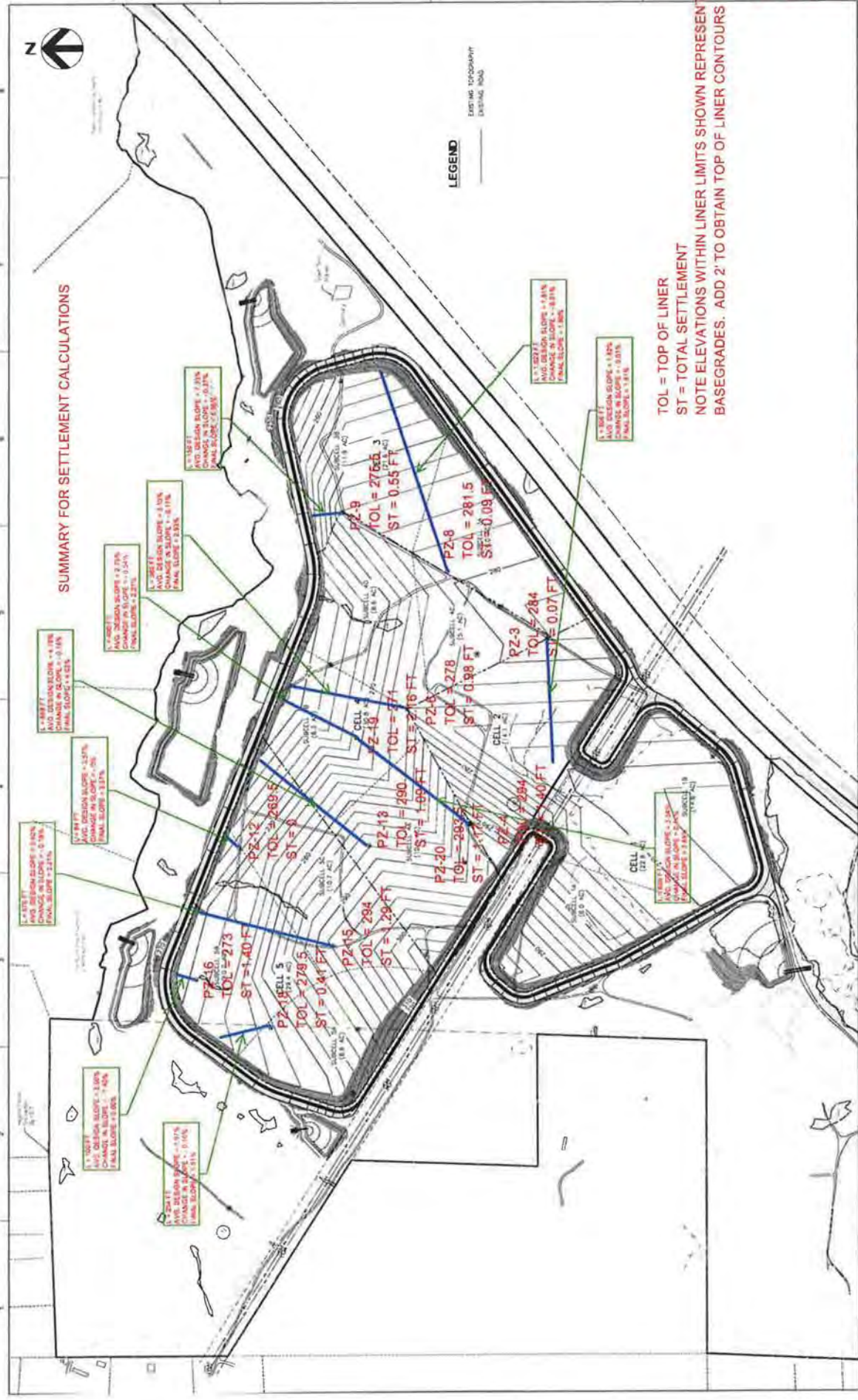

Charah
 COLON MINE SITE STRUCTURAL FILL
 SANFORD, NC

BASEGRADE PLAN (BOTTOM OF SOIL LINER)

PROJECT NUMBER: W-11-000000-02
 DATE: 07/13/11
 ISSUE: 01
 REVISION: 01

SCALE: 1" = 200'

FILE NAME: 00C-01.dwg
 DRAWN: J. J. JONES
 CHECKED: J. J. JONES

PROJECT NUMBER: 00C-03



HDR Engineering Inc.
 440 S. Church St. Suite 400
 Durham, NC 27601-2075
 919.286.8000

TOL = TOP OF LINER
 ST = TOTAL SETTLEMENT
 NOTE ELEVATIONS WITHIN LINER LIMITS SHOWN REPRESENT BASEGRADES. ADD 2' TO OBTAIN TOP OF LINER CONTOURS



Buxton Environmental, Inc. Consulting Services 1101 South Blvd., Suite 101 Charlotte, North Carolina 28203 Ph (704) 344-1450 Fax (704) 344-1451 buxtonenv@bellsouth.net		Boring Log, PZ-3s and 3		(Page 1 of 1)				
Sanford Mine Reclamation Site 1303 Brickyard Road Sanford, North Carolina		Date Started: : 7/16/14 Date Completed: : 7/16/14 Drilling Company: : Red Dog Drilling Drillers Name: : Mark Seiler NC Driller Certification: : 2789A		Logged By: : Ross Klingman, P.G. Drilling Method: : HSA; CME-45C Top-of-Casing Elev.: : 299.12'/299.29' Ground Surface Elev.: : 296.20' Natural, Cut, Fill Grade: : slight cut				
Depth (feet bgs.)	Elevation (feet asl.)	Blow Count/6-inches	Sampler Type	Recovery (in.)	Water Levels ▼ 1 Hour = dry/36.11'bgs ▽ 24 Hours = dry/30.91' bgs	Sample Type SS = Split Spoon ST = Shelby Tube RC = Rock Core BAG = Bag Sample	Lithologic Description	Well1: PZ-3s Well2: PZ-3 TOC Elev.: Cover
0 EL 5 CUT 10 MIA 15 PWR 20 25 30 35 40 45	296.2 291.2 286.2 281.2 276.2 271.2 266.2 261.2 256.2	66.4 76.11 71.8 154.4 50.8 50.5 50.2 50.5	SS,ST SS SS SS SS SS SS SS,BAG	16,24 14 14 16 7 9 5 6	moist; stiff; yellowish red (5YR 5/6) with light gray and orange yellow mottled; fine to coarse sandy gravelly clayey silt; low plasticity; cohesive; Soil Horizon; (Lab Results: PZ-3 UD (0-2'); USCS=CL, Sand=6.7%; Silt=52.8%; Clay=40.5%; Specific Gravity=2.67; Hydraulic Conductivity=2.42 x 10-6 cm/sec; Total Porosity=39.3%; Effective Porosity=2%; Atterberg Limits: PL=27, LL=48, PI=21) moist; very stiff; red (2.5YR 4/6) with white and brown specks; clayey fine to coarse sandy and gravelly silt; no plasticity; cohesive; Residuum dry; hard; reddish brown (2.5YR 5/4) with light orange and maroon mottles; clayey silt; no plasticity; cohesive; Residuum moist; very hard; red (10R 5/6) with maroon mottles and vertical manganese fracture planes; clayey silt; no plasticity; cohesive; Partially Weathered Rock dry; very hard; reddish brown (2.5YR 5/4) with olive green and white specks; fine to medium sandy silt with rock fragments; no plasticity; cohesive; Partially Weathered Rock dry; very compact; reddish brown (2.5YR 5/4) with white and green specks; medium horizontal fissile; silty fine to coarse sand with gravel; no plasticity or cohesion; Partially Weathered Rock dry; very hard; weak red (10R 5/3); highly horizontal fissile; fine mica sandy silt; no plasticity; cohesive; Partially Weathered Rock moist; weak red (10R 4/3) with green, yellow and black specks and mottles; slightly clayey silty fine to coarse sand with phyllite gravel; no plasticity or cohesion; Partially Weathered Rock; (Lab Results: PZ-3 Bag (34-34.5'); USCS=SM; Gravel=12.8%; Sand=59.7%; Silt and Clay=27.5%; Effective Porosity=30%)	6" Dia. Hollow-Stem Auger Boring Grout Bentonite Seal Casing (2" Dia. Sch. 40 PVC) #2 Silica Sand Pack Screen (10' Section of 2" Dia. Sch. 40 PVC) Total Depth (bgs.) = 23.45 Bentonite Seal #2 Silica Sand Pack Screen (10' Section of 2" Dia. Sch. 40 PVC) Total Depth (bgs.) = 37.05 Auger Refual @ 38'		



Buxton Environmental, Inc.
 Consulting Services
 1101 South Blvd., Suite 101
 Charlotte, North Carolina 28203
 Ph (704) 344-1450 Fax (704) 344-1451
 buxtonenv@bellsouth.net

Boring Log, PZ-4

(Page 1 of 1)

Sanford Mine Reclamation Site
 1303 Brickyard Road
 Sanford, North Carolina

Date Started: 7/16/14
 Date Completed: 7/16/14
 Drilling Company: Red Dog Drilling
 Drillers Name: Mark Seiler
 NC Driller Certification: 2789A

Logged By: Ross Klingman, P.G.
 Drilling Method: HSA; CME-45C
 Top-of-Casing Elev.: 299.50'(Lawrence Survey)
 Ground Surface Elev.: 298.82'(Lawrence Survey)
 Natural, Cut, Fill Grade: slight cut

Depth (feet bgs.)	Elevation (feet asl.)	Blow Count/6-inches	Sampler Type	Recovery (in.)	Water Levels	Sample Type	Lithologic Description
					▼ 1 Hour = dry ▽ 24 Hours = 33.22' bgs	SS = Split Spoon ST = Shelby Tube RC = Rock Core BAG = Bag Sample	
0	298.82	0/0.4	SS	14			moist; stiff; brownish yellow (10YR 6/8); fine to coarse sandy clayey silt with gravel; low plasticity; cohesive; Soil Horizon
5	291.82	0/0.4	SS, BAG	16			moist; stiff; brownish yellow (10YR 6/8) with rust mottles; silty clay; low plasticity; cohesive; Soil Horizon; (Lab Results: PZ-4 Bag (4-5.5'); USCS=CH; Sand=3.0%; Silt=50.9%; Clay=46.1%; Effective Porosity=2%; Atterberg Limits: PL=27, LL=60, PI=33)
10	286.82	12	SS	18			moist; very stiff; red (2.5YR 4/8) with olive green, rust, light gray and light purple mottled; gravelly clayey silt; no plasticity; cohesive; Residuum
15	281.82	27/5"	SS	12			dry; very hard; weak red (2.5YR 5/2) with light green specks; medium horizontal fissile; silt; no plasticity; cohesive; Partially Weathered Rock
20	276.82	28/3"	SS	12			dry; very hard; weak red (2.5YR 5/2) with white stringers and vertical black manganese fracture planes; silt; no plasticity; cohesive; Partially Weathered Rock
25	271.82	47/4"	SS, BAG	15			moist; very hard; red (2.5YR 4/6); highly horizontal fissile; very slightly clayey silt; no plasticity; cohesive; Partially Weathered Rock; (Lab Results: PZ-4 Bag (24-24.5'); USCS=CL; Sand=21.0%; Silt=61.6%; Clay=17.4%; Effective Porosity=11%; Atterberg Limits: PL=16, LL=31, PI=15)
30	266.82	34/2"	SS	20			moist; very hard; weak red (10R 4/2) with white, black and yellow specks and stringers; medium horizontal fissile; slightly clayey silt; no plasticity; cohesive; Partially Weathered Rock
35	261.82	50/0"	SS	0			No Recovery
Auger Refusal @ 36.7'							
40	256.82						
45							

ML
 CH
 MIT
 PHZ

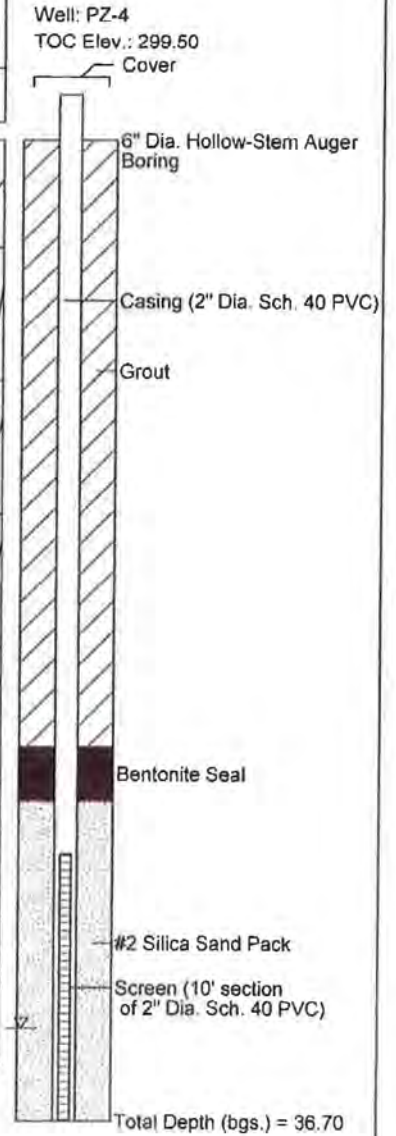



Buxton Environmental, Inc.
 Consulting Services
 1101 South Blvd., Suite 101
 Charlotte, North Carolina 28203
 Ph (704) 344-1450 Fax (704) 344-1451
 buxtonenv@bellsouth.net

Boring Log, PZ-6

(Page 1 of 1)

Sanford Mine Reclamation Site
 1303 Brickyard Road
 Sanford, North Carolina

Date Started: 7/17/14
 Date Completed: 7/17/14
 Drilling Company: Red Dog Drilling
 Drillers Name: Mark Seiler
 NC Driller Certification: 2789A

Logged By: Ross Klingman, P.G.
 Drilling Method: HSA; CME-45C
 Top-of-Casing Elev.: 286.13'(Lawrence Survey)
 Ground Surface Elev.: 283.48'(Lawrence Survey)
 Natural, Cut, Fill Grade: slight cut

Depth (feet bgs.)	Elevation (feet asl.)	Blow Count/6-inches	Sampler Type	Recovery (in.)	Water Levels	Sample Type	Lithologic Description
					▼ 1 Hour = dry ▽ 24 Hours = 19.30' bgs	SS = Split Spoon ST = Shelby Tube RC = Rock Core BAG = Bag Sample	
0	283.48	0	SS	10			moist; medium compact; yellow (10YR 7/6); horizontal fissle; silt; no plasticity or cohesion; Soil Horizon
5	278.48	13	SS	13			moist; medium; pale yellow (2.5 Y 7/4) with light rust mottles; silty clay with roots; low plasticity; cohesive; Soil Horizon
10	273.48	20	SS	20			moist; very stiff; dark reddish gray (2.5YR 4/1) with white and yellow mottles; silty clay; low plasticity; cohesive; Residuum
15	268.48	24	SS	24			moist; weak red (10R 4/4); clayey silt; no plasticity; cohesive; Residuum; (Lab Results: PZ-6 UD (10.5-11'); USCS=CL; Sand=11.3%, Silt=72.5%, Clay=16.2%; Specific Gravity=2.68; Hydraulic Conductivity=6.01 x 10 ⁻⁶ cm/sec; Total Porosity=30.7%; Effective Porosity=8%; Atterberg Limits: PL=23, LL=37, PI=14)
20	263.48	5	SS BAG	5			moist; very hard; red (2.5YR 4/6); fine to coarse sandy clayey silt with gravel and rock fragments; no plasticity; cohesive; Partially Weathered Rock
25	258.48	1	SS	1			dry; very hard; dark reddish brown (2.5YR 4/1); silty medium to coarse sand with rounded phyllite gravel; no plasticity; cohesive; Partially Weathered Rock; (Lab Results: PZ-6 Bag (19-19.5'); USCS=SC; Sand=59.9%; Silt=27.1%; Clay=13.0%; Effective Porosity=16%; Atterberg Limits: PL=18, LL=33, PI=15)
30	253.48	1	SS	1			moist; very hard; reddish brown (2.5YR 4/4); horizontal fissle; weathered mudstone; Partially Weathered Rock
35	248.48	1	SS	1			dry; very hard; weak red (2.5YR 5/2); horizontal fissle; sandy mudstone; Partially Weathered Rock
40	243.48						
45							



ML
 CL
 PWR



Buxton Environmental, Inc.
 Consulting Services
 1101 South Blvd., Suite 101
 Charlotte, North Carolina 28203
 Ph (704) 344-1450 Fax (704) 344-1451
 buxtonenv@bellsouth.net

Boring Log, PZ-8

(Page 1 of 1)

Sanford Mine Reclamation Site
 1303 Brickyard Road
 Sanford, North Carolina

Date Started: 7/21/14
 Date Completed: 7/21/14
 Drilling Company: Summit Engineering
 Drillers Name: Robert Cassell
 NC Driller Certification: 4143A

Logged By: Ross Klingman, P.G.
 Drilling Method: HSA; CME-550x
 Top-of-Casing Elev.: 304.85'(Lawrence Survey)
 Ground Surface Elev.: 302.58'(Lawrence Survey)
 Natural, Cut, Fill Grade: slight cut

Depth (feet bgs.)	Elevation (feet asl.)	Blow Count/6-inches	Sampler Type	Recovery (in.)	Water Levels	Sample Type	Lithologic Description	Well: PZ-8 TOC Elev.: 304.85 Cover
					▼ 1 Hour = dry ▽ 24 Hours = 41.38' bgs	SS = Split Spoon ST = Shelby Tube RC = Rock Core BAG = Bag Sample		
0	302.56		SS	18			moist; stiff; strong brown (7.5Y 5/8) with white specks; silty clay; medium plasticity; cohesive; Residuum	
5	297.56		SS	14			moist; stiff; red (2.5YR 4/6) with light orange mottles; silty clay; low plasticity; cohesive; Residuum	
10	292.56		SS	15			moist; stiff; red (2.5YR 4/6); silty clay; low plasticity; cohesive; Residuum	
15	287.56		SS,BAG	16			moist; very stiff; red (2.5YR 4/6) with orange mottles and black stringers; silty clay; low plasticity; cohesive; Residuum; (Lab Results: PZ-8 Bag (13.5-15'); USCS=CL; Sand=3.1%; Silt=68.1%; Clay=28.8%; Effective Porosity=3%; Atterberg Limits: PL=23, LL=39, PI=16)	
20	282.56		SS	14			moist; very stiff; red (10R 4/8) with light gray and yellow mottles; clayey quartz and phyllite gravelly silt; no plasticity; cohesive; Residuum	
25	277.56		SS	20			moist; very stiff; red (10R 4/6) with light gray and yellow mottles; clayey quartz and phyllite gravelly silt; no plasticity; cohesive; Residuum	
30	272.56		SS	20			moist; very hard; red (10R 4/8) with maroon mottles; silty clay; low plasticity; cohesive; Residuum	
35	267.56		SS	15			moist; very hard; red (10R 4/8) with maroon mottles; silty clay; low plasticity; cohesive; Residuum	
40	262.56		SS	12			dry; very compact; weak red (10R 4/4); clayey silty fine to coarse sand; no plasticity or cohesion; Partially Weathered Rock	
45			SS	10			moist; very hard; red (10R 4/8); highly horizontal fissile; silty clay; low plasticity; cohesive; Partially Weathered Rock	

CL

CWS

TOC

ML

▽ 274.75

PWP



Buxton Environmental, Inc.
 Consulting Services
 1101 South Blvd., Suite 101
 Charlotte, North Carolina 28203
 Ph (704) 344-1450 Fax (704) 344-1451
 buxtonenv@bellsouth.net

Boring Log, PZ-9s and 9

(Page 1 of 1)

Sanford Mine Reclamation Site
 1303 Brickyard Road
 Sanford, North Carolina

Date Started: 7/21/14
 Date Completed: 7/21/14
 Drilling Company: Summit Engineering
 Drillers Name: Robert Cassell
 NC Driller Certification: 4143A

Logged By: Ross Klingman, P.G.
 Drilling Method: HSA; CME-550x
 Top-of-Casing Elev.: 288.11'/288.11'
 Ground Surface Elev.: 285.74'
 Natural, Cut, Fill Grade: slight cut

Depth (feet bgs.)	Elevation (feet asl.)	Blow Count/6-inches	Sampler Type	Recovery (in.)	Water Levels ▼ 1 Hour = dry/dry ▽ 24 Hours = dry/38.03' bgs	Sample Type SS = Split Spoon ST = Shelby Tube RC = Rock Core BAG = Bag Sample	Lithologic Description	Well1: PZ-9s Well2: PZ-9 TOC Elev. 288.11' Cover
0	285.74	0	SS	18			moist; stiff; yellowish red (5YR 5/6) with rust mottles; silty clay; low plasticity; cohesive; Soil Horizon	
5	280.74	0	SS	16			moist; stiff; light yellow brown (2.5 Y 6/3) with light orange mottles; silty clay; low plasticity; cohesive; Soil Horizon	
10	275.74	0	SS	16			moist; stiff; light yellowish brown (2.5Y 6/3) with rust and maroon mottles; silty clay; low plasticity; cohesive; Soil Horizon	
15	270.74	13	SS, BAG	22			dry; compact; weak red (10R 4/3) with white and gray specks; silty fine to coarse sand with phyllite gravel; no plasticity or plasticity; Residuum; (Lab Results: PZ-9 Bag (13.5-15'); USCS=SC; Gravel=0.4%; Sand=52.2; Silt=35.9; Clay=11.5%; Effective Porosity=17; Atterberg Limits: PL=20, LL=34, PI=14)	
20	265.74	50/5"	SS	8			dry; very hard; weak red (10R 4/3); highly horizontal fissile; fine sandy silt; no plasticity; cohesive; Partially Weathered Rock	
25	260.74	34	SS	8			dry; very compact; weak red (10R 4/3) with white and gray specks; silty fine to coarse sand with phyllite gravel; no plasticity or cohesion, Partially Weathered Rock	
30	255.74	50/5"	SS	8			dry; very compact; weak red (10R 4/3) with white and gray specks; silty fine to coarse sand with phyllite gravel; no plasticity or cohesion; Partially Weathered Rock	
35	250.74	50/5"	SS	4			dry; very compact; weak red (10R 4/3) with white and gray specks; medium horizontal fissile; silty fine to coarse sand with phyllite gravel; no plasticity or cohesion; Partially Weathered Rock	
40	245.74	50/5"	SS	8			dry; very hard; reddish brown (2.5YR 4/4); highly horizontal fissile; weathered mudstone; Partially Weathered Rock	

CL
 SC
 PWR



Buxton Environmental, Inc.
 Consulting Services
 1101 South Blvd., Suite 101
 Charlotte, North Carolina 28203
 Ph (704) 344-1450 Fax (704) 344-1451
 buxtonenv@bellsouth.net

Boring Log, PZ-12

(Page 1 of 1)

Sanford Mine Reclamation Site
 1303 Brickyard Road
 Sanford, North Carolina

Date Started: 7/22/14
 Date Completed: 7/22/14
 Drilling Company: Summit Engineering
 Drillers Name: Robert Cassell
 NC Driller Certification: 4143A

Logged By: Ross Klingman, P.G.
 Drilling Method: HSA; CME-550x
 Top-of-Casing Elev.: 287.15' (Lawrence Survey)
 Ground Surface Elev.: 284.32' (Lawrence Survey)
 Natural, Cut, Fill Grade: natural

Depth (feet bgs.)	Elevation (feet asl.)	Blow Count/6-inches	Sampler Type	Recovery (in.)	Water Levels ▼ 1 Hour = dry ▽ 24 Hours = dry	Sample Type SS = Split Spoon ST = Shelby Tube RC = Rock Core BAG = Bag Sample	Lithologic Description	Well: PZ-12 TOC Elev.: 287.15
0	284.32		SS	16			moist; medium; yellowish red (5YR 5/8) with brown mottles; clayey, quartz gravelly silt and silty clay; low plasticity; cohesive; Soil Horizon	
5	279.32		SS	14			moist; stiff; reddish yellow (7.5YR 6/8) with rust and light gray mottles; silty clay; medium plasticity; cohesive; Soil Horizon	
10	274.32		SS	13			moist; stiff; red (2.5YR 4/6) with green and black specks; fine to medium sandy clayey silt; low plasticity; cohesive; Residuum	
15	269.32		SS	15			moist; very hard; red (2.5YR 4/6) with green and black specks; medium horizontal fissile; mica sandy clayey silt; no plasticity; cohesive; Partially Weathered Rock	
20	264.32		SS,BAG	21			moist; very stiff; red (2.5YR 4/6) with purple mottles; blocky; silty clay; no plasticity; cohesive; Residuum; (Lab Results: PZ-12 Bag (18.5-20'); USCS=CL; Sand=0.7%; Silt=66.5%; Clay=32.8%; Effective Porosity=2%; Atterberg Limits: PL=20, LL=42, PI=22)	
25	259.32		SS	8			dry; very hard; red (2.5YR 5/6); horizontal fissile; weathered fine sandy mudstone; Partially Weathered Rock	
30	254.32		SS	10			dry; very hard; red (2.5YR 5/6); horizontal fissile; weathered fine sandy mudstone; Partially Weathered Rock	
35	249.32							
40	244.32							
45								

CL
 CUT
 MIT
 PWR

253.21

Total Depth (bgs.) = 30.60'



Buxton Environmental, Inc.
 Consulting Services
 1101 South Blvd., Suite 101
 Charlotte, North Carolina 28203
 Ph (704) 344-1450 Fax (704) 344-1451
 buxtonenv@bellsouth.net

Boring Log, PZ-13

(Page 1 of 1)

Sanford Mine Reclamation Site
 1303 Brickyard Road
 Sanford, North Carolina

Date Started: 7/22/14
 Date Completed: 7/22/14
 Drilling Company: Summit Engineering
 Drillers Name: Robert Cassell
 NC Driller Certification: 4143A

Logged By: Ross Klingman, P.G.
 Drilling Method: HSA; CME-550x
 Top-of-Casing Elev.: 296.59'(Lawrence Survey)
 Ground Surface Elev.: 293.48'(Lawrence Survey)
 Natural, Cut, Fill Grade: natural

Depth (feet bgs.)	Elevation (feet asl.)	Blow Count/6-inches	Sampler Type	Recovery (in.)	Water Levels ▼ 1 Hour = dry ▽ 24 Hours = dry	Sample Type SS = Split Spoon ST = Shelby Tube RC = Rock Core BAG = Bag Sample	Lithologic Description	Well: PZ-12 TOC Elev.: 296.59	
								8" Dia. Hollow-Stem Auger Boring	Casing (2" Dia. Sch. 40 PVC)
0	293.48		SS,BAG	10			moist; medium compact; brownish yellow (10YR 6/6) with white specks; clayey silty quartz sandy gravel; no plasticity or cohesion; Soil Horizon; (Lab Results: PZ-13 Bag (0-1.5'); USCS=SC-SM, Gravel=36.1%; Sand=37.2%; Silt=19.4%; Clay=7.3%; Effective Porosity=25%; Atterberg Limits: PL=17, LL=21, PI=4)		
5	288.48		SS	21			moist; stiff; red (2.5YR 4/6); fine to medium sandy silt and silty clay layers; low plasticity; cohesive; Residuum		
10	288.48 293.40	50/5"	SS	6			moist; very hard; red (2.5YR 4/6); silty clay with large quartz gravel; no plasticity; cohesive; Residuum		
15	278.48	50/8"	SS	24			moist; very hard; weak red (10R 5/3) with light green mottles; medium horizontal fissle; silty clay; no plasticity; cohesive; Residuum		
20	273.48	50/8"	SS	20			moist; hard; pinkish gray (7.5YR 6/2) with black vertical and 45 degree planes; medium horizontal fissle; silty clay; no plasticity; cohesive; Residuum		
25	268.48	50/8"	SS	18			moist; very hard; gray (7.5YR 5/1); medium horizontal fissle; silty clay; no plasticity; cohesive; Partially Weathered Rock		
30	263.48	50/5"	SS	22			moist; very hard; gray (7.5YR 5/1); medium horizontal fissle; silty clay; no plasticity; cohesive; Residuum		
35	258.48	50/1"	SS	3			dry; very hard; dark blueish gray (Gley 2 4/1); weathered mudstone; Partially Weathered Rock		
40	253.48						Auger Refusal @ 35'		
45									

SC-SM
 ML
 CL
 PWR

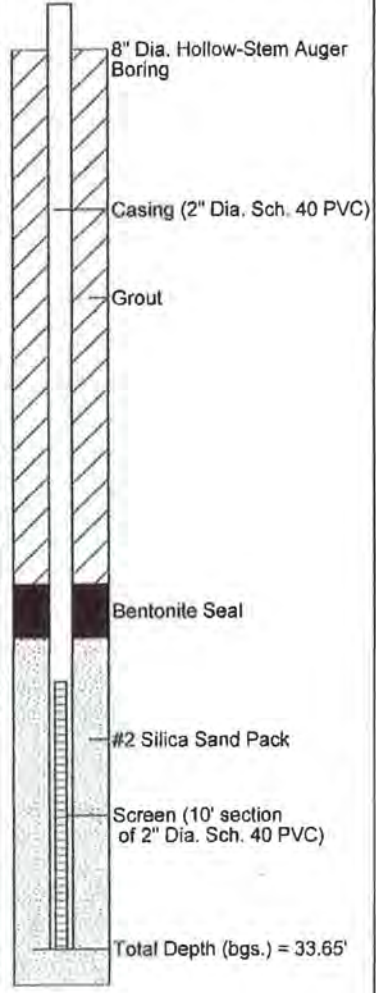



Buxton Environmental, Inc.
 Consulting Services
 1101 South Blvd., Suite 101
 Charlotte, North Carolina 28203
 Ph (704) 344-1450 Fax (704) 344-1451
 buxtonenv@bellsouth.net

Boring Log, PZ-15s and 15

(Page 1 of 1)

Sanford Mine Reclamation Site
 1303 Brickyard Road
 Sanford, North Carolina

Date Started: 7/23/14
 Date Completed: 7/23/14
 Drilling Company: Summit Engineering
 Drillers Name: Robert Cassell
 NC Driller Certification: 4143A

Logged By: Ross Klingman, P.G.
 Drilling Method: HSA; CME-550x
 Top-of-Casing Elev: 303.11/303.24'
 Ground Surface Elev.: 300.63'
 Natural, Cut, Fill Grade: natural

Depth (feet bgs.)	Elevation (feet asl.)	Blow Count/6-inches	Sampler Type	Recovery (in.)	Water Levels	Sample Type
					▼ 1 Hour = 13.48'/15.34' bgs ▽ 24 Hours = 13.65'/13.31' bgs	SS = Split Spoon ST = Shelby Tube RC = Rock Core BAG = Bag Sample
Lithologic Description						
0	300.63	0/5	SS	18	moist; medium; yellowish red (7.5YR 6/6); coarse quartz sandy silty clay; medium plasticity; cohesive; Soil Horizon	
5	295.63	9/11	SS	20	moist; very stiff; yellow (10YR 7/6) with rust and orange mottles; coarse quartz sandy silty clay; low plasticity; cohesive; Soil Horizon	
10	290.63	7/9	SS	21	moist; very stiff; red (2.5YR 4/6) with light gray and yellow mottles; silty clay; medium plasticity; cohesive; Residuum	
15	285.63	12/28	SS	18	moist; hard; red (10R 4/6) with white specks; blocky; silty clay; low plasticity; cohesive; Residuum	
20	280.63	24/50/4"	SS	18	moist; very hard; red (2.5YR 4/6) with white specks; blocky; silty clay; low plasticity; cohesive; Residuum	
25	275.63	50/6"	SS, BAG	16	wet; very hard; red (10R 4/6) with white specks; medium horizontal fissile; silty clay; low plasticity; cohesive; Partially Weathered Rock; (Lab Results: PZ-15 Bag (23.5-24'): USCS=CL; Gravel=0.7%; Sand=4.5%; Silt=52.8%; Clay=19.9%; Effective Porosity=8; Atterberg Limits: PI=16, LL=32, P _i =16)	
30	270.63	50/5"	SS	18	wet; very hard; weak red (10R 5/4) with light gray specks; highly horizontal fissile; weathered mudstone; Partially Weathered Rock	

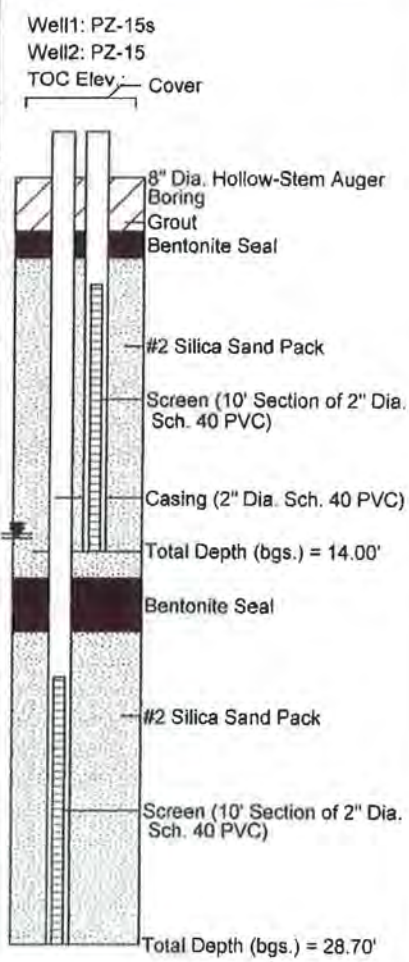

CL
 CUT
 TUL
 PWR



Buxton Environmental, Inc.
 Consulting Services
 1101 South Blvd., Suite 101
 Charlotte, North Carolina 28203
 Ph (704) 344-1450 Fax (704) 344-1451
 buxtonenv@bellsouth.net

Boring Log, PZ-16

(Page 1 of 1)

Sanford Mine Reclamation Site
 1303 Brickyard Road
 Sanford, North Carolina

Date Started: 7/23/14
 Date Completed: 7/23/14
 Drilling Company: Summit Engineering
 Drillers Name: Robert Cassell
 NC Driller Certification: 4143A

Logged By: Ross Klingman, P.G.
 Drilling Method: HSA; CME-550x
 Top-of-Casing Elev.: 272.78' (Lawrence Survey)
 Ground Surface Elev.: 270.63' (Lawrence Survey)
 Natural, Cut, Fill Grade: natural (drainage bottom)

Depth (feet bgs.)	Elevation (feet asl.)	Blow Count/6-inches	Sampler Type	Recovery (in.)	Water Levels	Sample Type	Lithologic Description	Well: PZ-16 TOC Elev.: 272.78 Cover
					▼ 1 Hour = 22.35' bgs ▽ 24 Hours = 8.33' bgs	SS = Split Spoon ST = Shelby Tube RC = Rock Core BAG = Bag Sample		
0	270.63	4	SS	24			moist; stiff; strong brown (7.5YR 5/6) with white specks; quartz gravelly clayey silt; no plasticity; cohesive; Soil Horizon	8" Dia. Hollow-Stem Auger Boring
5	265.63	16	SS	16			moist; stiff; yellowish red (5YR 4/6) with light gray mottles; silty clay; low plasticity; cohesive; Soil Horizon	Grout
10	260.63	33 35 39	SS	14			dry; very hard; dark red (10R 3/6); horizontal fissile; weathered mudstone; Residuum	Casing (2" Dia. Sch. 40 PVC)
15	255.63	17 31 50/5"	SS	16			moist; very hard; red (10R 4/6) with purple mottles; mica sandy silty clay; no plasticity; cohesive; Residuum	Bentonite Seal
20	250.63	58 1/2"	SS, BAG	10			moist; very hard; red (10R 4/6) with purple mottles; silty clay; no plasticity; cohesive; Partially Weathered Rock; (Lab Results: PZ-16 Bag (18.5-20'): USCS=CL; Sand=3.1%; Silt=65.5%; Clay=31.4%; Effective Porosity=3; Atterberg Limits: PI=19, LL=38, PI=19)	#2 Silica Sand Pack
25	245.63	50/3"	SS	6			wet; very hard; red (10R 4/6) with purple mottles; highly horizontal fissile; silty clay; no plasticity; cohesive; Partially Weathered Rock	Screen (10' section of 2" Dia. Sch. 40 PVC)
30	240.63							Total Depth (bgs.) = 24.00'
35	235.63							
40	230.63							
45								

273
 Fall
 12/11

CL

power

262.23



Buxton Environmental, Inc.
 Consulting Services
 1101 South Blvd., Suite 101
 Charlotte, North Carolina 28203
 Ph (704) 344-1450 Fax (704) 344-1451
 buxtonenv@bellsouth.net

Boring Log, PZ-18

(Page 1 of 1)

Sanford Mine Reclamation Site
 1303 Brickyard Road
 Sanford, North Carolina

Date Started: 7/23/14
 Date Completed: 7/23/14
 Drilling Company: Summit Engineering
 Drillers Name: Robert Cassell
 NC Driller Certification: 4143A

Logged By: Ross Klingman, P.G.
 Drilling Method: HSA: CME-550x
 Top-of-Casing Elev.: 294.72 (Lawrence Survey)
 Ground Surface Elev.: 292.27 (Lawrence Survey)
 Natural, Cut, Fill Grade: natural

Depth (feet bgs.)	Elevation (feet asl.)	Blow Count/6-inches	Sampler Type	Recovery (in.)	Water Levels	Sample Type	Lithologic Description
					▼ 1 Hour = dry ▽ 24 Hours = dry	SS = Split Spoon ST = Shelby Tube RC = Rock Core BAG = Bag Sample	
0	292.27	1/5	SS	22			moist; medium, brownish yellow (10R 6/6); slightly clayey silt; no plasticity; cohesive; Soil Horizon
5	287.27	4/5	SS	16			moist; stiff; reddish yellow (7.5YR 6/8) with tan and rust mottles; silty clay; medium plasticity; cohesive; Soil Horizon
10	282.27	5/12	SS	15			moist; very stiff; red (10R 4/8) with light green gray mottles; silty clay; low plasticity; cohesive; Residuum
15	277.27	27/24	SS	18			moist; hard; red (10R 4/8) with light green gray mottles; highly horizontal fissile; very fine sandy clayey silt; no plasticity; cohesive; Residuum
20	272.27	40/50/3"	SS, BAG	12			moist; very hard; red (10R 4/8) with light green gray mottles; highly horizontal fissile; very fine sandy clayey silt; no plasticity; cohesive; Partially Weathered Rock; (Lab Results: PZ-18 Bag (18.5-19.5'); USCS=CL; Sand=24.4%; Silt=55.7%; Clay=19.9%; Effective Porosity=8%; Atterberg Limits: PL=17, LL=32, PI=15)
25	267.27	9/50/3"	SS	10			moist; very hard; red (10R 4/8) with black horizontal planes; blocky and medium horizontal fissile; silty clay; no plasticity; cohesive; Partially Weathered Rock
30	262.27	50/6"	SS	6			moist; very hard; red (10R 4/8); highly horizontal fissile; weathered mudstone; Partially Weathered Rock
35	257.27	50/3"	SS	6			dry; very hard; weak red (10R 4/3); highly horizontal fissile; fine mica sandy silt; no plasticity; cohesive; Partially Weathered Rock
40	252.27	50/3"	SS	5			moist; very hard; red (10R 4/8); highly horizontal fissile; weathered mudstone; Partially Weathered Rock
45		50/3"	SS	4			moist; very hard; red (10R 4/8) with purple mottles; blocky; weathered mudstone; Partially Weathered Rock

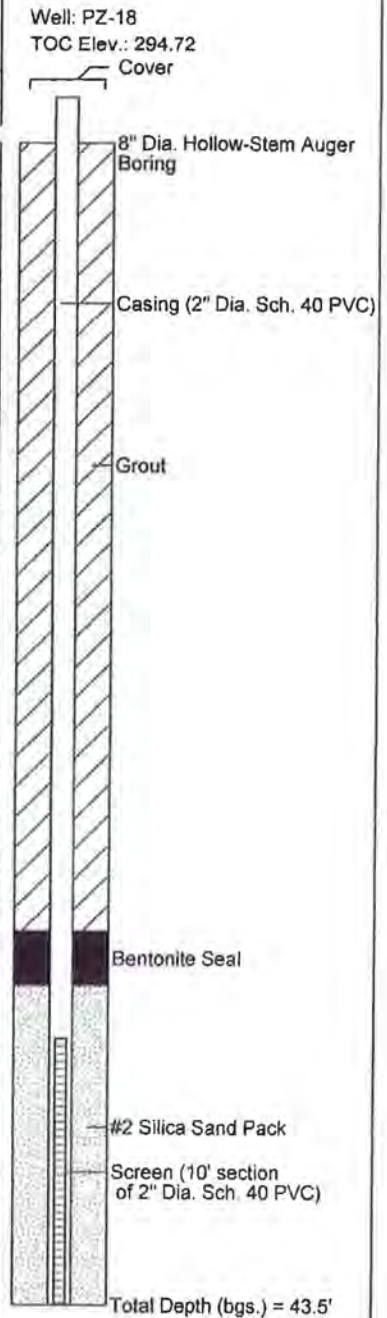

mit
 CL
 CWJ
 TOC
 MH
 PWR



Buxton Environmental, Inc.
 Consulting Services
 1101 South Blvd., Suite 101
 Charlotte, North Carolina 28203
 Ph (704) 344-1450 Fax (704) 344-1451
 buxtonenv@bellsouth.net

Boring Log, PZ-19

(Page 1 of 1)

Sanford Mine Reclamation Site
 1303 Brickyard Road
 Sanford, North Carolina

Date Started: : 8/29/14
 Date Completed: : 8/29/14
 Drilling Company: : Environmental Drilling & Probing
 Drillers Name: : Tommy Bolyard
 NC Driller Certification: : 3307

Logged By: : Ross Klingman, P.G.
 Drilling Method: : HSA; Geoprobe 7822
 Top-of-Casing Elev.: : (Lawrence Survey)
 Ground Surface Elev.: : 265.99'(Lawrence Survey)
 Natural, Cut, Fill Grade: : slight cut

Depth (feet bgs.)	Elevation (feet asl.)	Blow Count/6-inches	Sampler Type	Recovery (in.)	Water Levels	Sample Type	Lithologic Description	Well: PZ-19 TOC Elev.: Cover
					▼ 1 Hour = 11.00' bgs ▽ 24 Hours = 5.75' bgs	SS = Split Spoon ST = Shelby Tube RC = Rock Core BAG = Bag Sample		
0	265.99	23	SS	24			wet; medium; light brownish gray (10YR 6/2) with light orange mottles; silty clay; medium plasticity; cohesive; Soil Horizon	
5	260.99	26	SS	18			wet; soft; light brownish gray (10YR 6/2) with light orange mottles; silty clay; medium plasticity; cohesive; Soil Horizon	
10	255.99	27	SS	17			moist; hard; yellowish brown (10YR 5/4); medium horizontal fissile; clayey silt; no plasticity; cohesive; Residium	
15	250.99	27	SS	24			moist; very hard; yellowish brown (10YR 5/4) with black manganese planes; medium horizontal fissile; clayey silt; no plasticity; cohesive; Residium	
20	245.99	27	SS	10			dry; very hard; brown (10YR 5/3); highly horizontal fissile; weathered mudstone; Partially Weathered Rock	
25	240.99	27	SS	12			wet; very hard; reddish brown (5YR 4/3); medium horizontal fissile; weathered mudstone; Partially Weathered Rock	
30	235.99							
35	230.99							
40	225.99							
45								

FSL
 CL
 MH
 PWR



Buxton Environmental, Inc.
 Consulting Services
 1101 South Blvd., Suite 101
 Charlotte, North Carolina 28203
 Ph (704) 344-1450 Fax (704) 344-1451
 buxtonenv@bellsouth.net

Boring Log, PZ-20

(Page 1 of 1)

Sanford Mine Reclamation Site
 1303 Brickyard Road
 Sanford, North Carolina

Date Started: : 8/29/14
 Date Completed: : 8/29/14
 Drilling Company: : Environmental Drilling & Probing
 Drillers Name: : Tommy Bolyard
 NC Driller Certification: : 3307

Logged By: : Ross Klingman, P.G.
 Drilling Method: : HSA; Geoprobe 7822
 Top-of-Casing Elev.: : (Lawrence Survey)
 Ground Surface Elev.: : 296.51'(Lawrence Survey)
 Natural, Cut, Fill Grade: : natural

Depth (feet bgs.)	Elevation (feet asl.)	Blow Count/6-inches	Sampler Type	Recovery (in.)	Water Levels ▼ 1 Hour = 24.00' bgs ▽ 24 Hours = 12.44' bgs	Sample Type SS = Split Spoon ST = Shelby Tube RC = Rock Core BAG = Bag Sample	Lithologic Description	Well: PZ-20 TOC Elev.: Cover
0	296.51		SS	24			moist; medium; Red (2.5YR 4/6) with yellow mottles; fine sandy silty clay; low plasticity; cohesive; Soil Horizon	
5	291.51		SS	24			moist; stiff; red (2.5YR 4/6) with yellow mottles; fine sandy silty clay; low plasticity; cohesive; Soil Horizon	
10	286.51		SS	20			moist; stiff; red (2.5YR 4/6) with yellow mottles; mica sandy silty clay; low plasticity; cohesive; Soil Horizon	
15	281.51		SS	18			very moist; stiff; weak red (10R 4/4) with white and light gray specks; phyllite and quartz gravelly sandy silty clay; no plasticity; cohesive; Residium	
20	276.51	50/3"	SS	8			dry; very hard; weak red (10R 4/4) with white and light gray specks; weathered mudstone; Partially Weathered Rock	
25	271.51	50/4"	SS	8			wet; very hard; red (10R 4/6); highly horizontal fissile; mica sandy clayey silt; no plasticity; cohesive; Partially Weathered Rock	
30	266.51							
35	261.51							
40	256.51							
45								

CUT
 CC
 PWR



NOTES

1. POTENTIAL MAP PREPARED BY LANCE BURDICK OF HOBBS & ASSOCIATES, INC. DATED AUGUST 21, 2014.
2. GROUNDWATER POTENTIOMETRIC CONTOURS GENERATED UTILIZING AUTOCAD DRAWING AND INTERPOLATION SOFTWARE BY HOBBS ENGINEERING, INC. PREPARED BY ROSS ALKMAN, P.E. WITH BURDICK ENGINEERING, INC.
3. GROUNDWATER CONTOURS WERE GENERATED WITH THE SHALLOWEST DEPTH BASED ON WATER LEVEL READINGS COLLECTED ON JULY 28 AND AUGUST 13, 2014. THE MOST EXTENDED GROUNDWATER LEVEL OCCURRED ON AUGUST 13, 2014.
4. READER ATTENTION: INCLUDING ENLARGED WATER LEVEL POND AND WATER LEVELS AT POTENTIOMETER PZ-19 (-10 FEET BELOW GRADE) AND POTENTIOMETER PZ-20 (-10 FEET BELOW GRADE) AND POTENTIOMETER PZ-21 (-10 FEET BELOW GRADE) AND POTENTIOMETER PZ-22 (-10 FEET BELOW GRADE) AND POTENTIOMETER PZ-23 (-10 FEET BELOW GRADE) AND POTENTIOMETER PZ-24 (-10 FEET BELOW GRADE) AND POTENTIOMETER PZ-25 (-10 FEET BELOW GRADE) AND POTENTIOMETER PZ-26 (-10 FEET BELOW GRADE) AND POTENTIOMETER PZ-27 (-10 FEET BELOW GRADE) AND POTENTIOMETER PZ-28 (-10 FEET BELOW GRADE) AND POTENTIOMETER PZ-29 (-10 FEET BELOW GRADE) AND POTENTIOMETER PZ-30 (-10 FEET BELOW GRADE) AND POTENTIOMETER PZ-31 (-10 FEET BELOW GRADE) AND POTENTIOMETER PZ-32 (-10 FEET BELOW GRADE) AND POTENTIOMETER PZ-33 (-10 FEET BELOW GRADE) AND POTENTIOMETER PZ-34 (-10 FEET BELOW GRADE) AND POTENTIOMETER PZ-35 (-10 FEET BELOW GRADE) AND POTENTIOMETER PZ-36 (-10 FEET BELOW GRADE) AND POTENTIOMETER PZ-37 (-10 FEET BELOW GRADE) AND POTENTIOMETER PZ-38 (-10 FEET BELOW GRADE) AND POTENTIOMETER PZ-39 (-10 FEET BELOW GRADE) AND POTENTIOMETER PZ-40 (-10 FEET BELOW GRADE) AND POTENTIOMETER PZ-41 (-10 FEET BELOW GRADE) AND POTENTIOMETER PZ-42 (-10 FEET BELOW GRADE) AND POTENTIOMETER PZ-43 (-10 FEET BELOW GRADE) AND POTENTIOMETER PZ-44 (-10 FEET BELOW GRADE) AND POTENTIOMETER PZ-45 (-10 FEET BELOW GRADE) AND POTENTIOMETER PZ-46 (-10 FEET BELOW GRADE) AND POTENTIOMETER PZ-47 (-10 FEET BELOW GRADE) AND POTENTIOMETER PZ-48 (-10 FEET BELOW GRADE) AND POTENTIOMETER PZ-49 (-10 FEET BELOW GRADE) AND POTENTIOMETER PZ-50 (-10 FEET BELOW GRADE) AND POTENTIOMETER PZ-51 (-10 FEET BELOW GRADE) AND POTENTIOMETER PZ-52 (-10 FEET BELOW GRADE) AND POTENTIOMETER PZ-53 (-10 FEET BELOW GRADE) AND POTENTIOMETER PZ-54 (-10 FEET BELOW GRADE) AND POTENTIOMETER PZ-55 (-10 FEET BELOW GRADE) AND POTENTIOMETER PZ-56 (-10 FEET BELOW GRADE) AND POTENTIOMETER PZ-57 (-10 FEET BELOW GRADE) AND POTENTIOMETER PZ-58 (-10 FEET BELOW GRADE) AND POTENTIOMETER PZ-59 (-10 FEET BELOW GRADE) AND POTENTIOMETER PZ-60 (-10 FEET BELOW GRADE) AND POTENTIOMETER PZ-61 (-10 FEET BELOW GRADE) AND POTENTIOMETER PZ-62 (-10 FEET BELOW GRADE) AND POTENTIOMETER PZ-63 (-10 FEET BELOW GRADE) AND POTENTIOMETER PZ-64 (-10 FEET BELOW GRADE) AND POTENTIOMETER PZ-65 (-10 FEET BELOW GRADE) AND POTENTIOMETER PZ-66 (-10 FEET BELOW GRADE) AND POTENTIOMETER PZ-67 (-10 FEET BELOW GRADE) AND POTENTIOMETER PZ-68 (-10 FEET BELOW GRADE) AND POTENTIOMETER PZ-69 (-10 FEET BELOW GRADE) AND POTENTIOMETER PZ-70 (-10 FEET BELOW GRADE) AND POTENTIOMETER PZ-71 (-10 FEET BELOW GRADE) AND POTENTIOMETER PZ-72 (-10 FEET BELOW GRADE) AND POTENTIOMETER PZ-73 (-10 FEET BELOW GRADE) AND POTENTIOMETER PZ-74 (-10 FEET BELOW GRADE) AND POTENTIOMETER PZ-75 (-10 FEET BELOW GRADE) AND POTENTIOMETER PZ-76 (-10 FEET BELOW GRADE) AND POTENTIOMETER PZ-77 (-10 FEET BELOW GRADE) AND POTENTIOMETER PZ-78 (-10 FEET BELOW GRADE) AND POTENTIOMETER PZ-79 (-10 FEET BELOW GRADE) AND POTENTIOMETER PZ-80 (-10 FEET BELOW GRADE) AND POTENTIOMETER PZ-81 (-10 FEET BELOW GRADE) AND POTENTIOMETER PZ-82 (-10 FEET BELOW GRADE) AND POTENTIOMETER PZ-83 (-10 FEET BELOW GRADE) AND POTENTIOMETER PZ-84 (-10 FEET BELOW GRADE) AND POTENTIOMETER PZ-85 (-10 FEET BELOW GRADE) AND POTENTIOMETER PZ-86 (-10 FEET BELOW GRADE) AND POTENTIOMETER PZ-87 (-10 FEET BELOW GRADE) AND POTENTIOMETER PZ-88 (-10 FEET BELOW GRADE) AND POTENTIOMETER PZ-89 (-10 FEET BELOW GRADE) AND POTENTIOMETER PZ-90 (-10 FEET BELOW GRADE) AND POTENTIOMETER PZ-91 (-10 FEET BELOW GRADE) AND POTENTIOMETER PZ-92 (-10 FEET BELOW GRADE) AND POTENTIOMETER PZ-93 (-10 FEET BELOW GRADE) AND POTENTIOMETER PZ-94 (-10 FEET BELOW GRADE) AND POTENTIOMETER PZ-95 (-10 FEET BELOW GRADE) AND POTENTIOMETER PZ-96 (-10 FEET BELOW GRADE) AND POTENTIOMETER PZ-97 (-10 FEET BELOW GRADE) AND POTENTIOMETER PZ-98 (-10 FEET BELOW GRADE) AND POTENTIOMETER PZ-99 (-10 FEET BELOW GRADE) AND POTENTIOMETER PZ-100 (-10 FEET BELOW GRADE).

- LEGEND
- SINGLE SHALLOW OR INTERMEDIATE MEZONETER
 - ⊕ NESTED SHALLOW AND INTERMEDIATE MEZONETER MAP
 - ⊙ NESTED INTERMEDIATE AND DEEP POTENTIOMETER MAP (WITH ROCK CORE)
 - ⬤ GEOTECHNICAL SOIL BORING (COTINCHAK) (APPROX. LOCATIONS FOR B-1, B-2, B-4 & B-5)
 - ▲ SURFACE WATER TANK
 - ▲ INTERIOR METAL GROUNDWATER ELEVATIONS (277.5E)
 - TOP OF WATER DIVISION (PZ-1 TO PZ-11)
 - GROUNDWATER POTENTIOMETRIC CONTOUR
 - - - - - GROUNDWATER FLOW DIRECTION
 - POTENTIOMETRIC MAP

GROUNDWATER POTENTIOMETRIC MAP

COLON MINE SITE STRUCTURAL FILL
SANFORD, NC

ISSUE NUMBER	DESCRIPTION	DATE	BY	APP'D.

Prepared by:
HOBBS ENGINEERING, INC.
445 S. CHERRY ST. SUITE 100
SANFORD, NC 28787
TEL: 704.896.1000 FAX: 704.896.1001



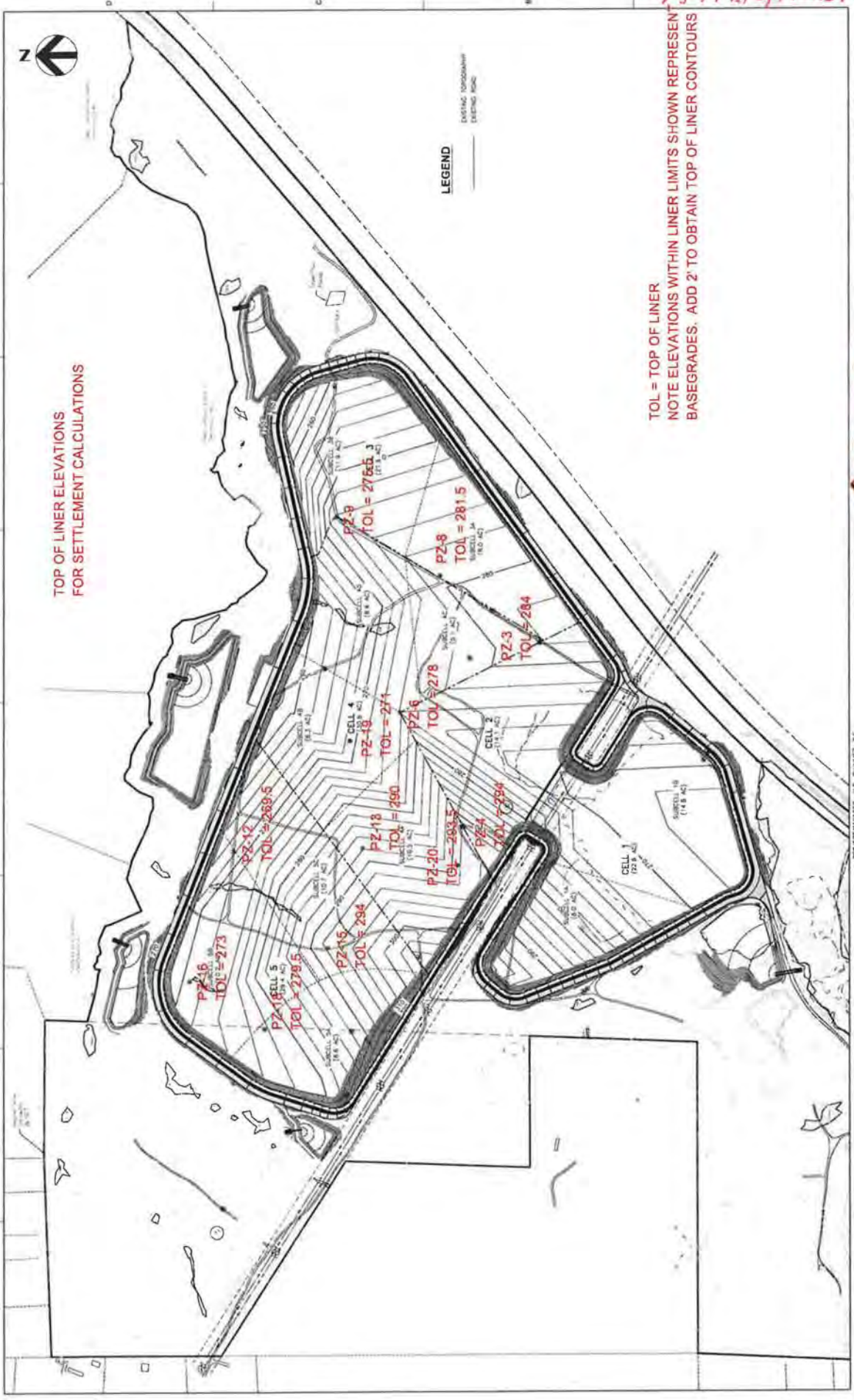

BASEGRADE PLAN (BOTTOM OF SOIL LINER)

PROJECT NUMBER: 00C-03 Rev 2
 SHEET: 00C-03 Rev 2
 SCALE: 1" = 200'



ISSUE	DATE	DESCRIPTION

High Engineering, Inc.
 440 S. Church St., Suite 1000
 Durham, NC 27602-2615
 919.286.1234



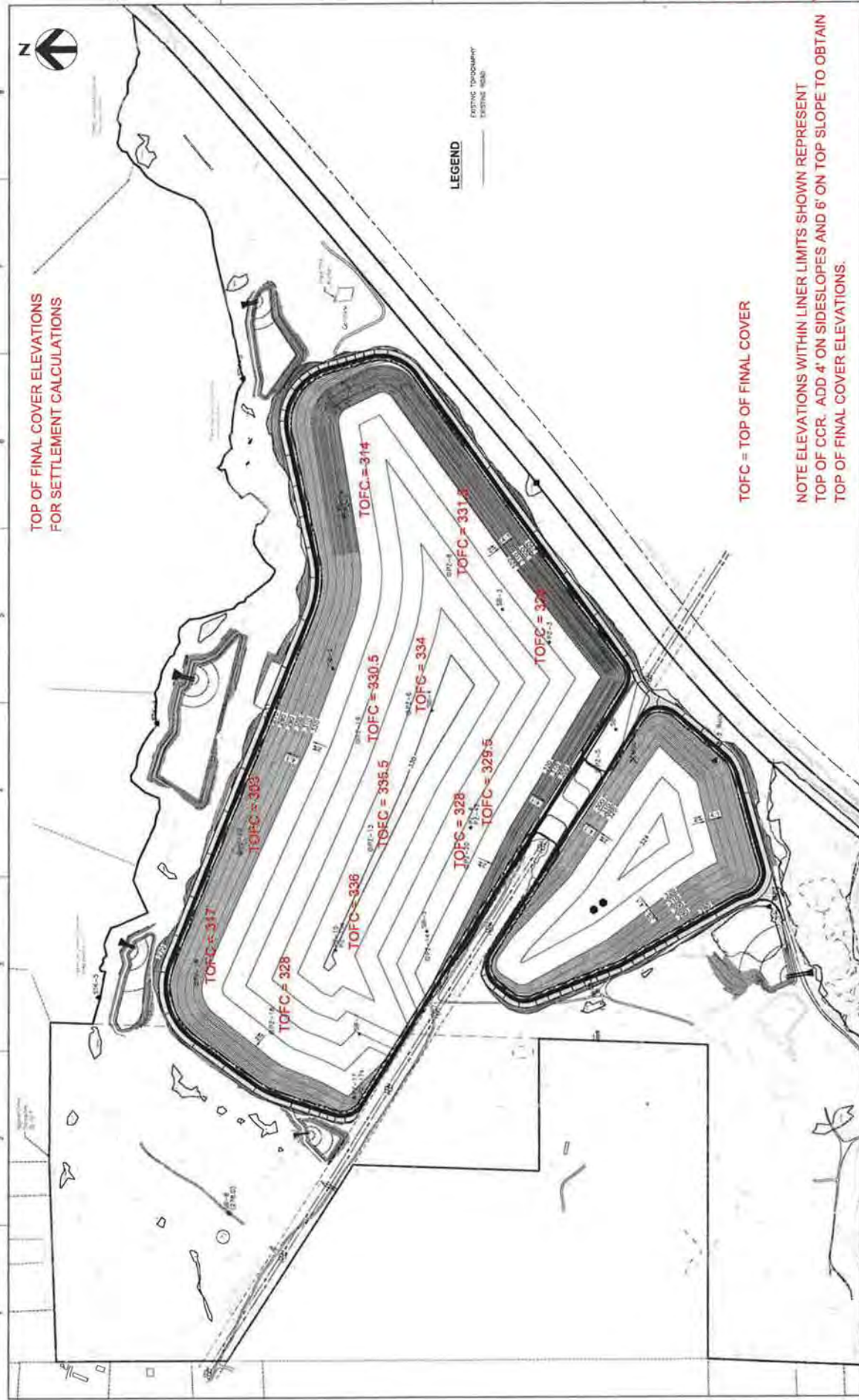

TOP OF FINAL COVER ELEVATIONS FOR SETTLEMENT CALCULATIONS

TOFC = TOP OF FINAL COVER

NOTE ELEVATIONS WITHIN LINER LIMITS SHOWN REPRESENT TOP OF CCR. ADD 4' ON SIDESLOPES AND 6' ON TOP SLOPE TO OBTAIN TOP OF FINAL COVER ELEVATIONS.

LEGEND

EXISTING TOPOGRAPHY
EXISTING ROAD

PROPOSED FINAL CLOSURE PLAN

DATE: 08/22/19
SCALE: 1"=300'

PROJECT NUMBER: 00C-02

Charah
COLON MINE SITE STRUCTURAL FILL
SANFORD, NC

PROJECT MANAGER	A.C. LAMAR, P.E.
DATE	08/22/19
STATUS	ISSUED FOR REVIEW
REVISION	
PROJECT NUMBER	00C-02

USI Engineering, Inc.
143 E. DAVIS ST. SUITE 200
CHARLOTTE, NC 28203-2791
TEL: 704.366.4444



TABLE 6
Typical Values of Soil Index Properties

	Particle Size and Gradation				Voids (1)				Unit Weight (2) (lb./cu.ft.)					
	Approximate Size Range (mm)		Approx. D ₁₀ (mm)	Approx. Range Uniform Coefficient C _u	Void Ratio		Porosity (%)		Dry Weight		Wet Weight		Submerged Weight	
	D _{max}	D _{min}			e _{cr}	e _{min} dense	D _{max} loose	D _{min} dense	100% Mod. AASHO	Min loose	Max dense	Min loose	Max dense	Min loose
GRANULAR MATERIALS														
Uniform Materials														
a. Equal spheres (theoretical values)	-	-	-	1.0	-	0.35	47.6	26	-	-	-	-	-	-
b. Standard Ottawa SAND	0.84	0.59	0.67	1.1	0.75	0.50	44	33	92	110	93	131	57	69
c. Clean, uniform SAND (fine or medium)	-	-	-	1.2 to 2.0	0.80	0.40	50	29	83	118	84	136	52	73
d. Uniform, inorganic SILT	0.05	0.005	0.012	1.2 to 2.0	1.1	0.40	52	29	80	118	81	136	51	73
Well-graded Materials														
a. Silty SAND	2.0	0.005	0.02	5 to 10	0.90	0.30	47	23	87	127	88	142	54	79
b. Clean, fine to coarse SAND	2.0	0.05	0.09	4 to 6	0.95	0.20	49	17	85	138	86	148	53	86
c. Micaceous SAND	-	-	-	15 to 300	1.2	0.40	55	29	76	120	77	138	48	76
d. Silty SAND & GRAVEL	100	0.005	0.02	15 to 300	0.85	0.14	46	12	89	146(3)	90	155(3)	56	92
MIXED SOILS														
Sandy or Silty CLAY	2.0	0.001	0.003	10 to 30	1.8	0.25	64	20	60	130	100	147	38	85
Skip-graded Silty CLAY with stones or rk frags	250	0.001	-	-	1.0	0.20	50	17	84	140	115	151	53	89
Well-graded GRAVEL, SAND, SILT & CLAY mixture	250	0.001	0.002	25 to 1000	0.70	0.13	41	11	100	148(4)	125	156(4)	62	94
CLAY SOILS														
CLAY (30%-50% clay sizes) Colloidal CLAY (-0.002 mm: 50%)	0.05	0.5μ	0.001	-	2.4	0.50	71	33	50	112	94	133	31	71
ORGANIC SOILS	0.01	10μ	-	-	12	0.60	92	37	13	106	71	128	8	66
ORGANIC SILT	-	-	-	-	3.0	0.55	75	35	40	110	87	131	25	69
ORGANIC CLAY (30% - 50% clay sizes)	-	-	-	-	4.4	0.70	81	41	30	100	81	125	18	62

ML/MH

SC/SM

MH/CL
Grainy-MH

CH

Source: Ref. 1

Young's modulus of soil, E_s , and the constrained modulus of soil, M_s , where E_s and D_s are related through Poisson's ratio of soil, ν_s , by

$$M_s = \frac{E_s \cdot (1 - \nu_s)}{(1 + \nu_s)(1 - 2 \cdot \nu_s)} \quad (9.27)$$

where M_s = constrained modulus of soil, lb/ft² or kN/m²;
 E_s = elastic modulus of soil, lb/ft² or kN/m²; and
 ν_s = Poisson's ratio of soil.

The studies and analyses by Neilson (1967), Allgood and Takahashi (1972), and Hartely and Duncan (1987) indicated that for

$$E' = k \cdot M_s \quad (9.28)$$

the value of k may vary from 0.7 to 2.3. Using $k = 1.5$ as a representative value and $\nu_s = 0.3$, in addition to combining Equations 9.27 and 9.28 yields the following relationship between the elastic modulus of the pipe and soil (Selig, 1990):

$$E' = 2 \cdot E_s \quad (9.29)$$

The values of elastic parameters, E_s and ν_s , can be found in Table 9.5 according to different percents of density from a standard Proctor compaction test (ASTM D698).

TABLE 9.5 Elastic Soil Parameters (Selig, 1990)

Soil Type	Stress Level		85% Standard Density			95% Standard Density		
			E_s		ν_s	E_s		ν_s
	psi	kPa	psi	MPa		psi	MPa	
SW, SP, GW, GP	1	7	1,300	9	0.26	1,600	11	0.40
	5	35	2,100	14	0.21	4,100	28	0.29
	10	70	2,600	18	0.19	6,000	41	0.24
	20	140	3,300	23	0.19	8,600	59	0.23
	40	280	4,100	28	0.23	13,000	90	0.25
	60	420	4,700	32	0.28	16,000	110	0.29
GM, SM, ML, and GC, SC with < 20% fines	1	7	600	4	0.25	1,800	12	0.34
	5	35	700	5	0.24	2,500	17	0.29
	10	70	800	6	0.23	2,900	20	0.27
	20	140	850	6	0.30	3,200	22	0.29
	40	280	900	6	0.38	3,700	25	0.32
	60	420	1,000	7	0.41	4,100	28	0.35
CH, CL, MH, GC, SC	1	7	100	1	0.33	400	3	0.42
	5	35	250	2	0.29	800	6	0.35
	10	70	400	3	0.28	1,100	8	0.32
	20	140	600	4	0.25	1,300	9	0.30
	40	280	700	5	0.35	1,400	10	0.35
	60	420	800	6	0.40	1,500	10	0.36

Source: Ref. 3

9.4.2 Pipe Wall Buckling

Buckling can occur in flexible pipes subject to internal pressures in compact conduits (e.g., high velocity) resisting buckling.

Most conduits have a certain resistance. An exact elastic medium entails a number of uncertainties in the solution is not necessarily a simple formula for comp

Where,

- P_{cr} = critical
- E' = modul
- μ = Poisso
- E = modul
- I = mome
- in⁴/in
- r = mean

Because $I = r^3$,

where

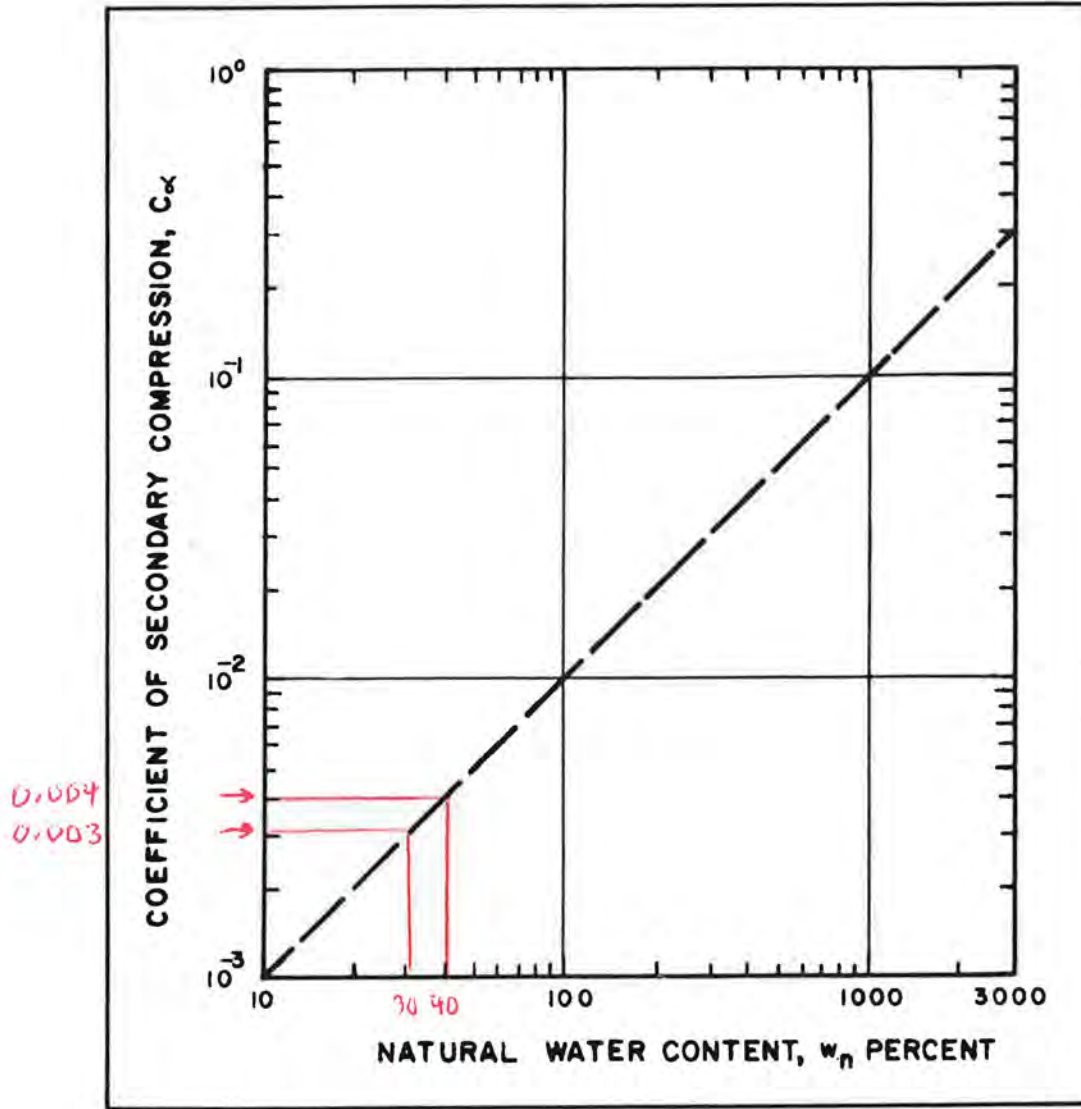
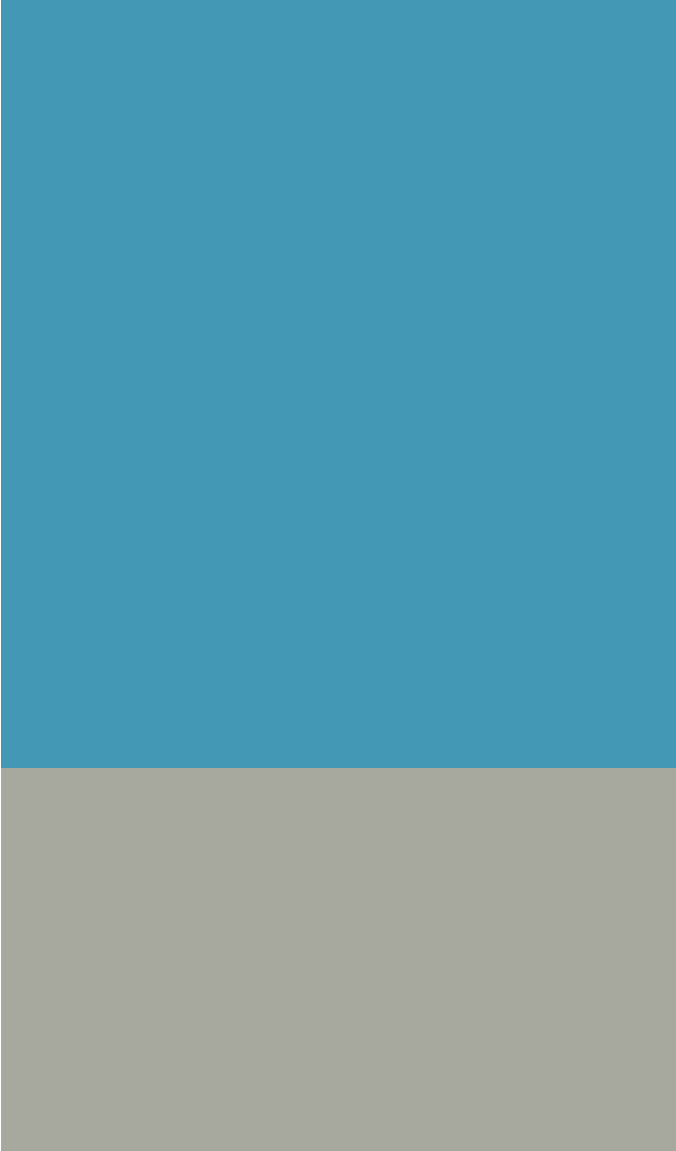

FIGURE 16
Coefficient of Secondary Compression as Related to
Natural Water Content

Source: Ref. 1

This page intentionally left blank.



B

Stability

Slope Stability Analysis
Final Cover Veneer Stability (Options 1 and 2)
Operational Cover Veneer Stability

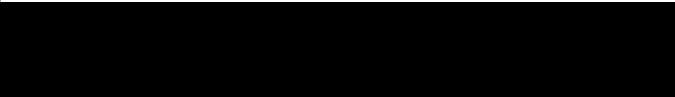



This page intentionally left blank.

HDR Computation

Project: Charah Colon Mine	Computed By: TMY	Date: 10/27/2014
Subject: Permit Application	Checked By: KP	Date: 10/29/2014
Task: Slope Stability Analyses	Sheet: 1	Of: 3

Objective:

Evaluate the slope stability of the proposed coal ash structural fill. Evaluate both global stability of the foundation soils, the stability of the structural fill ash slope, and the sliding block stability of the ash along the bottom liner system using PCSTABL 5M and the STEDwin editor (Ref. 3).

References:

1. Naval Facilities Engineering Command (1986). Design Manual 7.01 - Soil Mechanics.
2. Bowles, J.E. (1984). Physical and Geotechnical Properties of Soils. McGraw-Hill.
3. Van Aller, H.W. (1999 - 2013). STEDwin 2.88 (32 bit), The Smart Editor for PCSTABL 5M. Annapolis Engineering Software.
4. Naval Facilities Engineering Command (1982). Design Manual 7.02 - Foundations and Earth Structures.
5. Koerner, G.R. and D. Narejo (2005). Direct Shear Database of Geosynthetic-to-Geosynthetic and Geosynthetic-to-Soil Interfaces. GRI Report #30.

Steps:

1. Estimate subsurface conditions beneath the structural fill using soil boring logs provided by Buxton Environmental, Inc. (see Attachment A). Based on the boring logs, the typical soil profile for the site consists of approximately 5' soil horizon consisting of medium silty and clayey soils underlain by approximately 10' of stiff residuum. Hard partially weathered rock (PWR) underlies the residuum. For the purposes of global stability, it is assumed that failure surfaces will not penetrate the PWR. The estimated intervals of the soil horizon, residuum, and PWR are shown in Attachment A.
2. Estimate the coal ash parameters for input into PCSTABL 5M using physical characterization testing information provided by Charah for samples obtained at the Riverbend Steam Station. This testing information, performed by Geotrack Technologies, Inc., is provided in Attachment B. An estimate of the compacted unit weight (γ) of the ash was obtained based on the results of a standard Proctor test assuming the material would be placed at maximum dry density and optimum moisture content. Total and effective stress strength properties of the coal ash were obtained from the Triaxial Shear Test reports provided in Attachment B. The total stress parameters are applicable for undrained conditions when loading occurs over a relatively short time which leads to the development of excess pore water pressures within the ash. The effective stress parameters are applicable for drained conditions when loading occurs over a sufficient amount of time to allow excess pore water pressures to dissipate. Since typical hydraulic conductivity values for fly ash generally range between 1×10^{-4} to 1×10^{-5} cm/sec, it is not clear whether undrained or drained conditions will develop within the ash therefore both sets of parameters were analyzed. The assumed values for unit weight (γ), friction angle (ϕ), and cohesion (c) for the ash are provided below:
 - Compacted Ash (Total Stress): $\gamma = 83.8$ pcf, $\phi = 8^\circ$, $c = 4,300$ psf
 - Compacted Ash (Effective Stress): $\gamma = 83.8$ pcf, $\phi = 22^\circ$, $c = 2,600$ psf
3. Estimate foundation soil parameters for input into PCSTABL 5M. Use Ref. 1 to correlate γ based with soil type (see Attachment C). From information provided in soil borings (Attachment A), which includes geotechnical laboratory classification data, use Attachments D and E to correlate total and effective stress parameters for the soil horizon and residuum, respectively (see Ref. 2). Note that in Attachment D, $c = 1/2 q_u$ where q_u is the unconfined compressive strength of the soil. Since the PWR at the site is classified as "hard" with blowcounts generally in excess of 50/6in, it is assumed that failure surfaces will not enter the PWR and therefore parameters were not assigned to this layer. Since the foundation soils are generally fine grained at the site, it is not clear whether undrained or drained conditions will develop within the soils, therefore both sets of parameters were analyzed. The assumed values for unit weight (γ), friction angle (ϕ), and cohesion (c) for the foundation soils are provided below:
 - Soil Horizon (Total Stress): $\gamma = 120$ pcf, $\phi = 0^\circ$, $c = 470$ psf
 - Soil Horizon (Effective Stress): $\gamma = 120$ pcf, $\phi = 31^\circ$, $c = 0$
 - Residuum (Total Stress): $\gamma = 130$ pcf, $\phi = 0^\circ$, $c = 1,045$ psf
 - Residuum (Effective Stress): $\gamma = 130$ pcf, $\phi = 32^\circ$, $c = 0$ psf
4. Estimate soil parameters for the compacted soil berm that will be constructed along the perimeter of the structural fill. Assume on site soils consisting of predominantly clayey and silt soils will be used. Use Attachment F (Ref. 1) to obtain obtain estimated strength parameters and Attachment C to estimate γ as shown below:
 - Compacted Clayey Fill: $\gamma = 125$ pcf, $\phi = 28^\circ$, $c = 1,800$ psf

HDR Computation

Project: Charah Colon Mine	Computed By: TMY	Date: 10/27/2014
Subject: Permit Application	Checked By: KP	Date: 10/29/2014
Task: Slope Stability Analyses	Sheet: 2	Of: 3

5. Estimate soil parameters for the final cover soils. Since a variety of soils may be used for final cover and considering that a high degree of compaction of the final cover probably can not be achieved without the risk of damaging the underlying geomembrane, conservatively assume the following parameters:

Final Cover soils: $\gamma = 120$ pcf, $\phi = 30^\circ$, $c = 0$ psf

6. Determine critical liner interface for sliding block analyses. A detail of the proposed liner system is provided below. Determine typical interface strength parameters for each interface based on Attachment G (Ref. 5) for each interface as shown below. Use peak parameters which are appropriate to use before failure initiates. Based on this information, the critical (i.e. lowest strength) interface is between the textured 60 mil HDPE geomembrane and the saturated cohesive soil. Therefore, use these parameters for the critical interface.

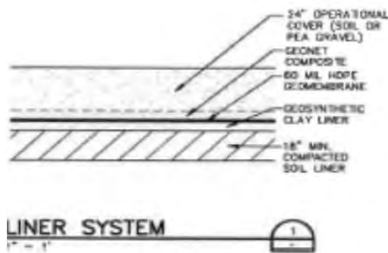

Geocomposite/Granular Soil Interface: $\phi = 33^\circ$, $c = 0$

Critical \rightarrow Geocomposite/Textured HDPE Interface: $\phi = 26^\circ$, $c = 0$

Textured HDPE/Saturated Reinforced GCL: $\phi = 23^\circ$, $c = 167$ psf

Saturated Reinforced GCL/Saturated Cohesive Soil: $\phi = 29^\circ$, $c = 0$

7. Determine most critical cross-section for stability analysis. Factors to consider include proposed ash height, liner slope, foundation conditions, perimeter berm height, and water table location. Using this criteria, a critical stability section was selected along the northern side of the structural fill. The location of this section is shown superimposed on the Basegrade Plan (Attachment H), the Proposed Final Closure Plan (Attachment I), and a groundwater contour map (Attachment J). This section (north slope) represents the greatest depth of waste that will be placed and therefore the greatest amount of driving forces leading to potential failure. The section also represents an area where the perimeter berm will be constructed above existing grade and therefore there will be less buttressing effect at the toe of the slope.

8. Determine the peak ground acceleration for the site for use in the seismic stability analyses. From Attachment K (Ref. 6), the estimated peak ground acceleration for the site with a 2% probability of exceedance in 50 years (equivalent to 10% probability of exceedance in 250 years) is 0.09g. This value was entered as a horizontal pseudo-static coefficient in the PCSTABL 5M seismic analyses.

9. Using the information developed in Steps 1 through 7, input the data into PCSTABL 5M using the STEDwin editor (Ref. 3). Evaluate the both the global stability of the foundation soils beneath the structural fill as well as the stability of the ash slope and sliding block failure along the bottom liner system.

Results/Conclusions

Plots showing the output results from the PCSTABL 5M analyses for the global, ash slope, and sliding block stability under both static and seismic conditions are attached to this calculation. The minimum factors of safety are summarized in the table below. The most critical analysis was for the sliding block failure along the bottom liner system under effective stress conditions with factors of safety of 4.33 and 3.03 for static and seismic conditions, respectively. The generally accepted minimum static and seismic factors of safety for landfill stability are 1.5 and 1.0, respectively. Since the calculated factors of safety exceed the minimum acceptable, the proposed structural fill is adequately stable.

Since the interface shear strength parameters for the liner system components can vary significantly based on soil and product properties, it is helpful to determine the minimum ϕ value required for the interfaces to achieve an adequate factor of safety. The last two plots show the minimum ϕ required to achieve factors of safety of 1.5 and 1.0 for static and seismic analyses, respectively. The plots show that along the critical cross section, very little friction is required along the bottom liner interfaces due to the buttressing effect of the perimeter berm. Due to variations of slope along the structural fill liner system and temporary loading conditions during filling, however, it is recommended that a minimum bottom liner interface ϕ of 26 be required. This requirement should be confirmed by project specific interface shear strength testing.

HDR Computation

Project: Charah Colon Mine	Computed By: TMY	Date: 10/27/2014
Subject: Permit Application	Checked By: KP	Date: 10/29/2014
Task: Slope Stability Analyses	Sheet: 3	Of: 3

Analysis	Static FS	Seismic FS
Global/Static/Total Stress	4.72	3.21
Global/Static/Effective Stress	4.95	3.49
Ash Slope/Static/Total Stress	4.50	3.08
Ash Slope/Static/Effective Stress	5.20	3.69
Sliding Block/Static/Total Stress	5.02	3.55
Sliding Block/Static/Effective Stress	4.33	3.03 ← Critical Analysis
Minimum ϕ Required for Static FS = 1.5	0°	
Minimum ϕ Required for Seismic FS = 1.0	0°	

This page intentionally left blank.

Charah Colon Mine Structural Fill Global - Static (Total Stress)

c:\users\tyanosch\documents\istedwin and stablccm1a.pl2 Run By: Tom Yanoschak 10/6/2014 09:49AM

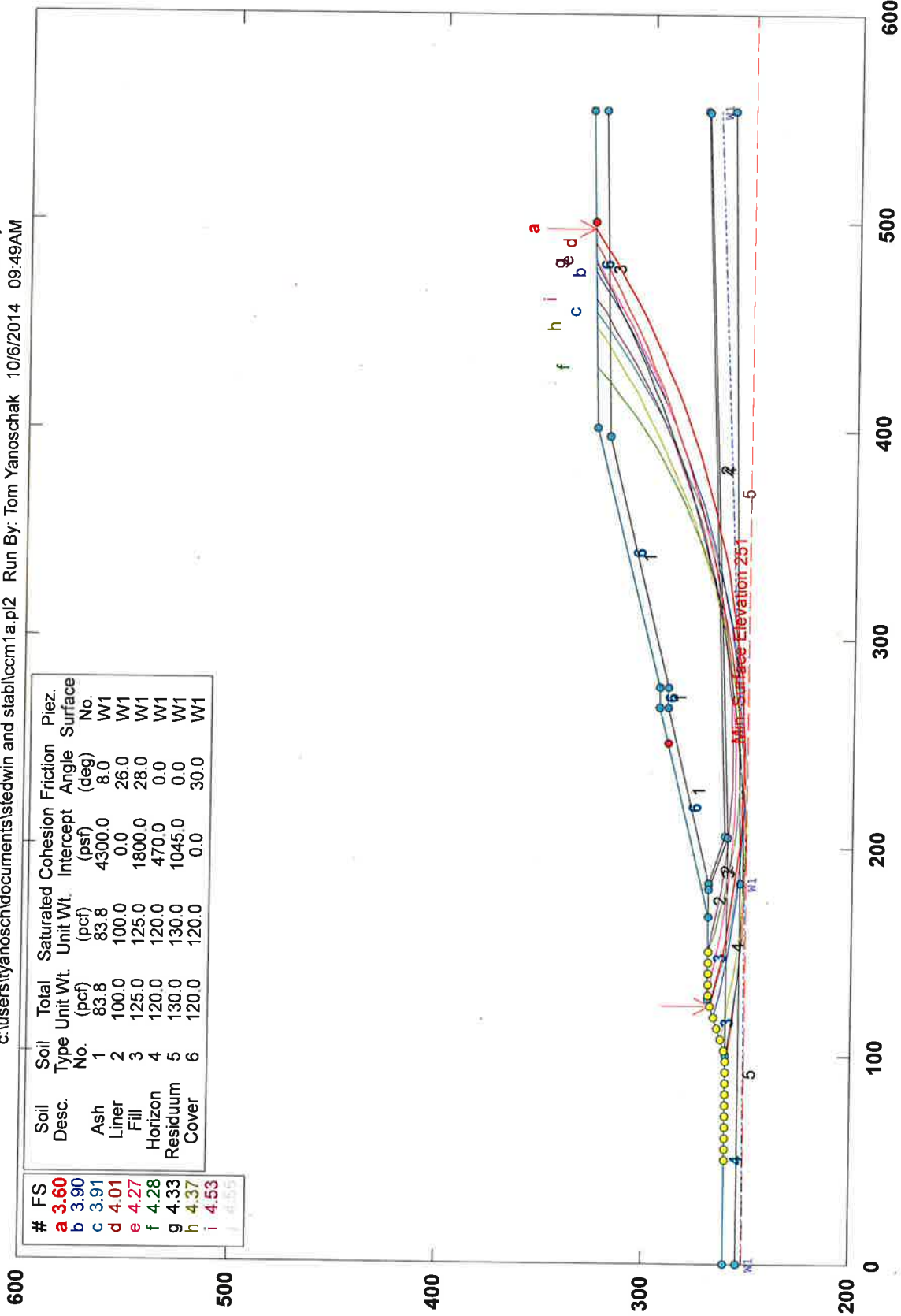

#	FS	Soil Desc.	Soil Type No.	Total Unit Wt. (pcf)	Saturated Unit Wt. (pcf)	Cohesion Intercept (psf)	Friction Angle (deg)	Piez. Surface No.
a	3.60	Ash	1	83.8	100.0	4300.0	8.0	W1
b	3.90	Liner	2	100.0	100.0	0.0	26.0	W1
c	3.91	Fill	3	125.0	125.0	1800.0	28.0	W1
d	4.01	Horizon	4	120.0	120.0	470.0	0.0	W1
e	4.27	Residuuum	5	130.0	130.0	1045.0	0.0	W1
f	4.28	Cover	6	120.0	120.0	0.0	30.0	W1
g	4.33							
h	4.37							
i	4.53							

PCSTABL5M/si FSmin=3.60
Safety Factors Are Calculated By The Modified Bishop Method

Charah Colon Mine Structural Fill Global - Seismic (Total Stress)

c:\users\tyanosch\documents\istedwin and stabl\ccm1sa.pl2 Run By: Tom Yanoschak 10/6/2014 09:53AM

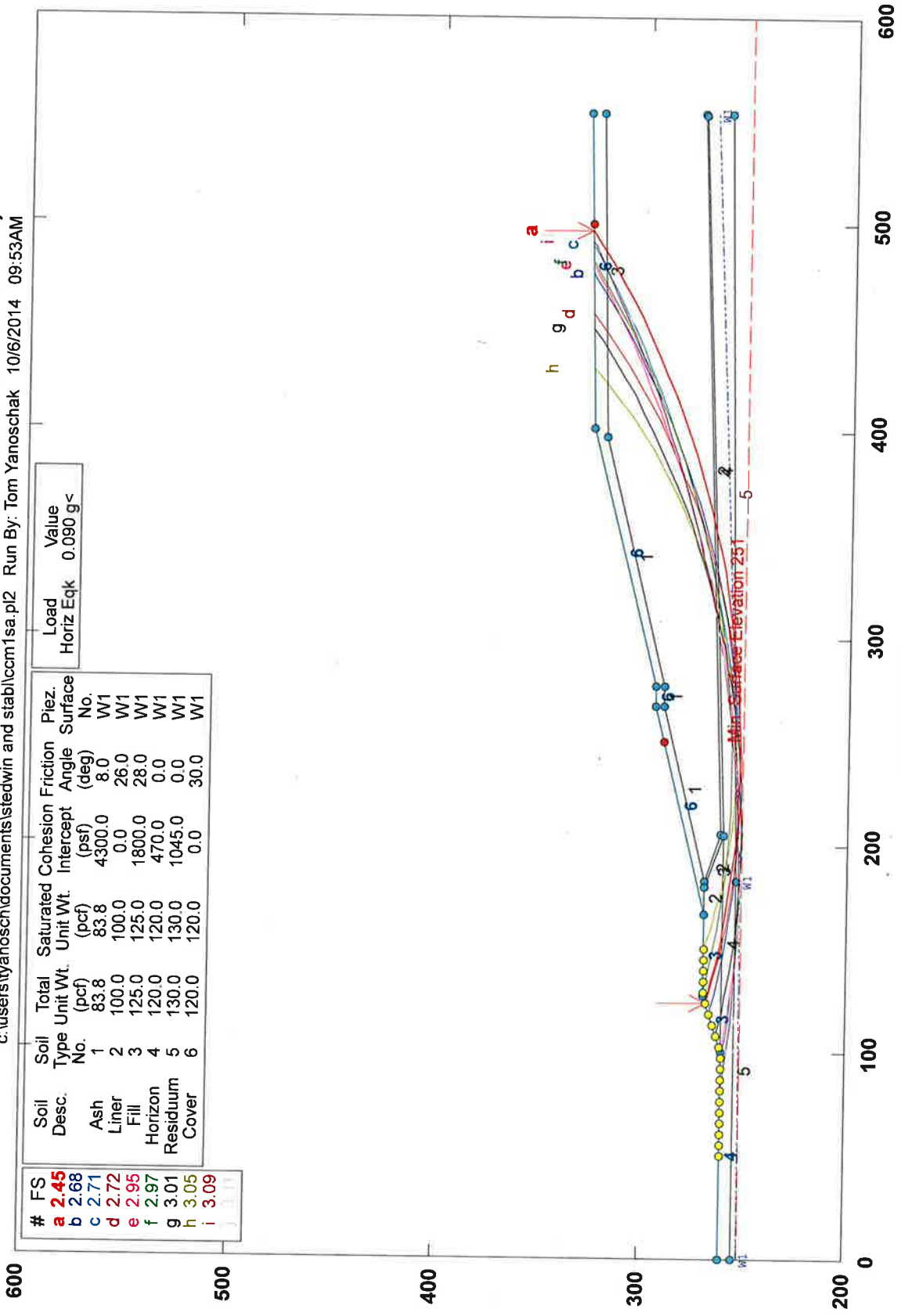

#	FS
a	2.45
b	2.68
c	2.71
d	2.72
e	2.95
f	2.97
g	3.01
h	3.05
i	3.09

Soil Desc.	Soil Type No.	Total Unit Wt. (pcf)	Saturated Unit Wt. (pcf)	Cohesion (psf)	Friction Angle (deg)	Piez. Surface No.
Ash	1	83.8	83.8	4300.0	8.0	W1
Liner	2	100.0	100.0	0.0	26.0	W1
Fill	3	125.0	125.0	1800.0	28.0	W1
Horizon	4	120.0	120.0	470.0	0.0	W1
Residuum	5	130.0	130.0	1045.0	0.0	W1
Cover	6	120.0	120.0	0.0	30.0	W1

Load Horiz Eqk	Value
0.090	g<

PCSTABL5M/si FSmin=2.45
Safety Factors Are Calculated By The Modified Bishop Method

Charah Colon Mine Structural Fill Global - Static (Effective Stress)

c:\users\yanosch\documents\stabilwin and stabilccm2a.pl2 Run By: Tom Yanoschak 10/6/2014 10:30AM

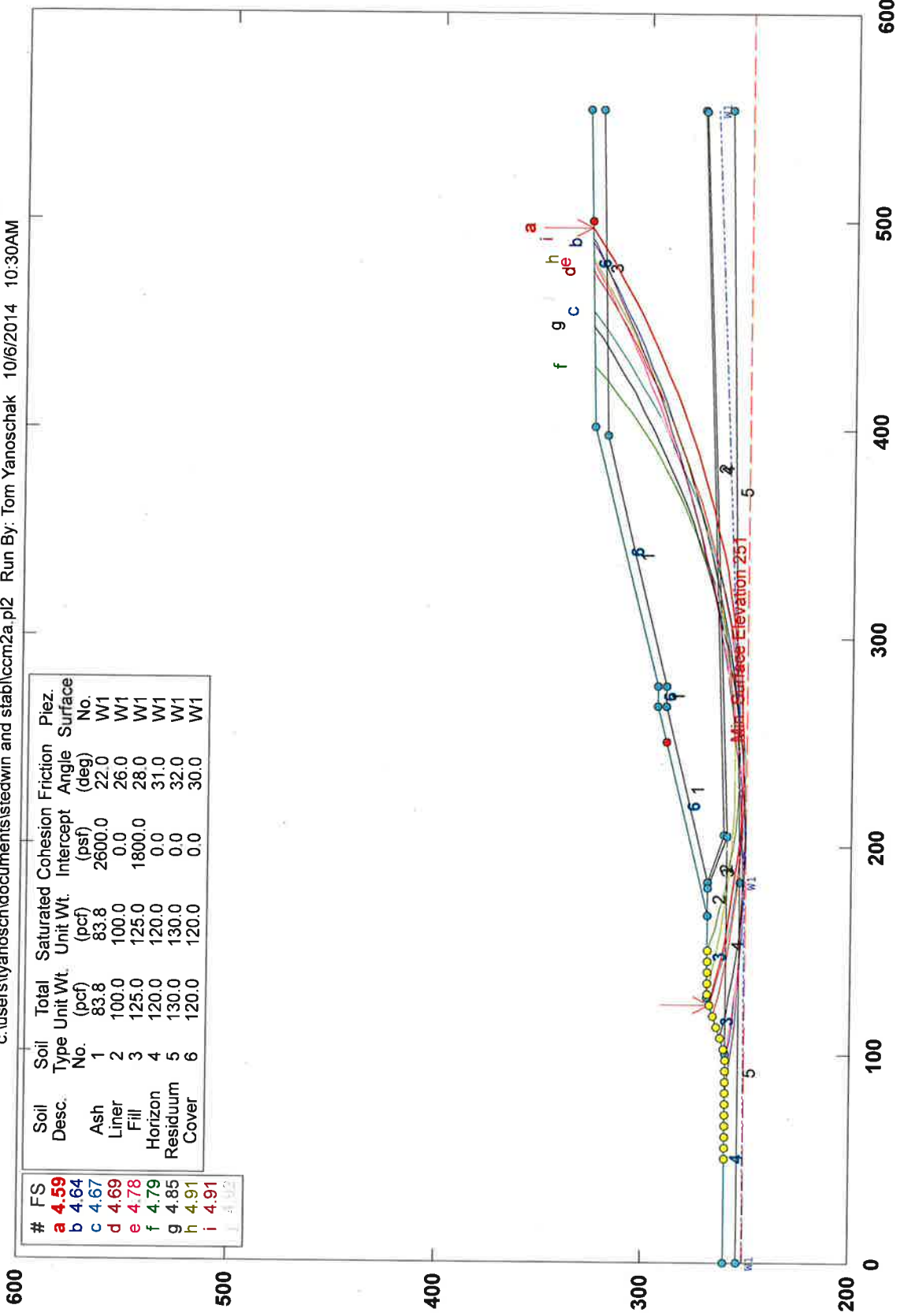

#	FS	Soil Desc.	Soil Type No.	Total Unit Wt. (pcf)	Saturated Unit Wt. (pcf)	Cohesion Intercept (psf)	Friction Angle (deg)	Piez. Surface No.
a	4.59	Ash	1	83.8	83.8	2600.0	22.0	W1
b	4.64	Liner	2	100.0	100.0	0.0	26.0	W1
c	4.67	Fill	3	125.0	125.0	1800.0	28.0	W1
d	4.69	Horizon	4	120.0	120.0	0.0	31.0	W1
e	4.78	Residuuum	5	130.0	130.0	0.0	32.0	W1
f	4.79	Cover	6	120.0	120.0	0.0	30.0	W1
g	4.85							
h	4.91							
i	4.92							

PCSTABL5M/si FSmin=4.59
Safety Factors Are Calculated By The Modified Bishop Method

Charah Colon Mine Structural Fill Global - Seismic (Effective Stress)

c:\users\tyanosch\documents\stedwin and stab\ccm2sa.pl2 Run By: Tom Yanoschak 10/6/2014 10:35AM

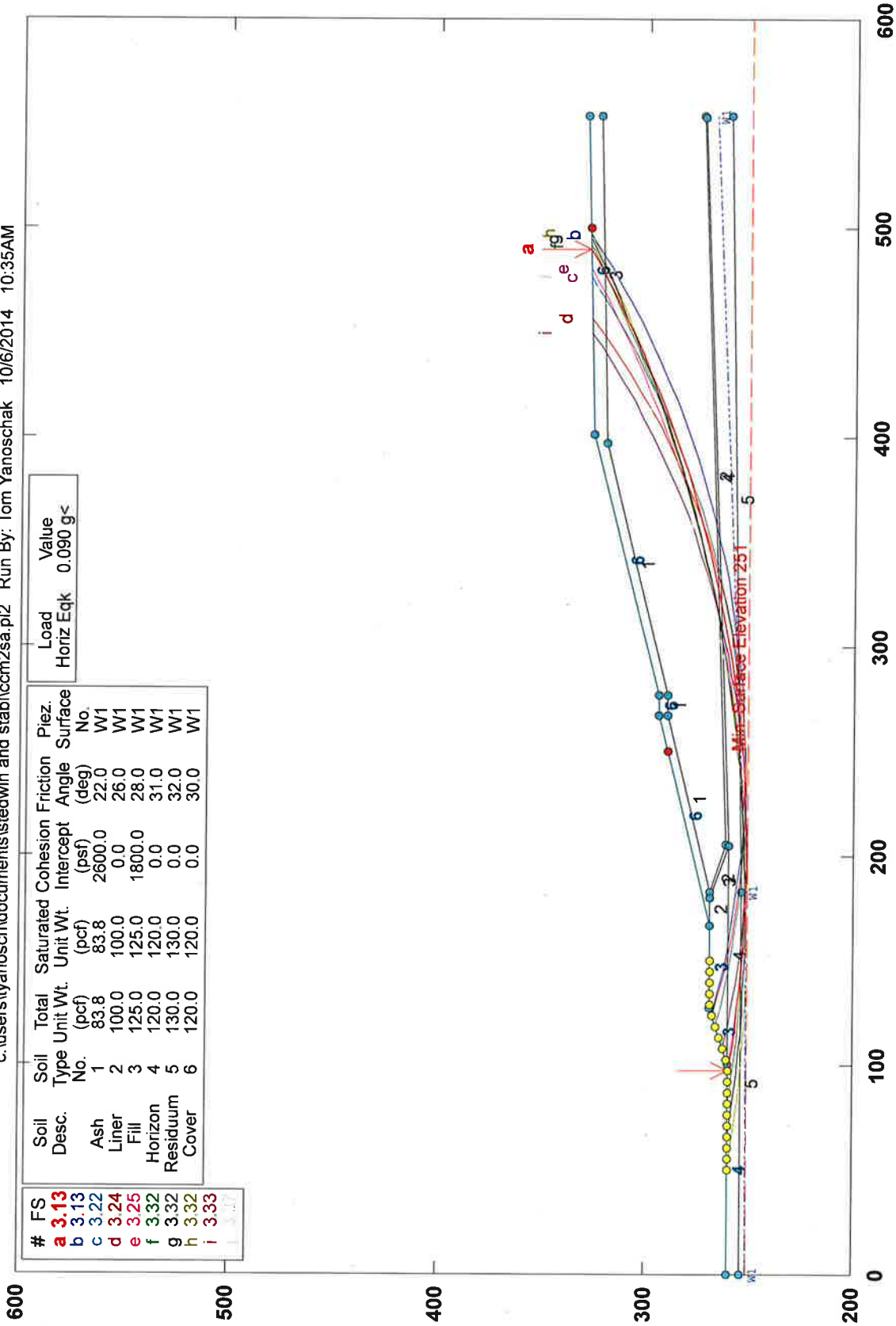

PCSTABL5M/si FSmin=3.13
 Safety Factors Are Calculated By The Modified Bishop Method

Charah Colon Mine Structural Fill Ash Slope - Static (Total Stress)

c:\users\tyanosch\documents\stedwin and stablccm3a.pl2 Run By: Tom Yanoschak 10/6/2014 10:48AM

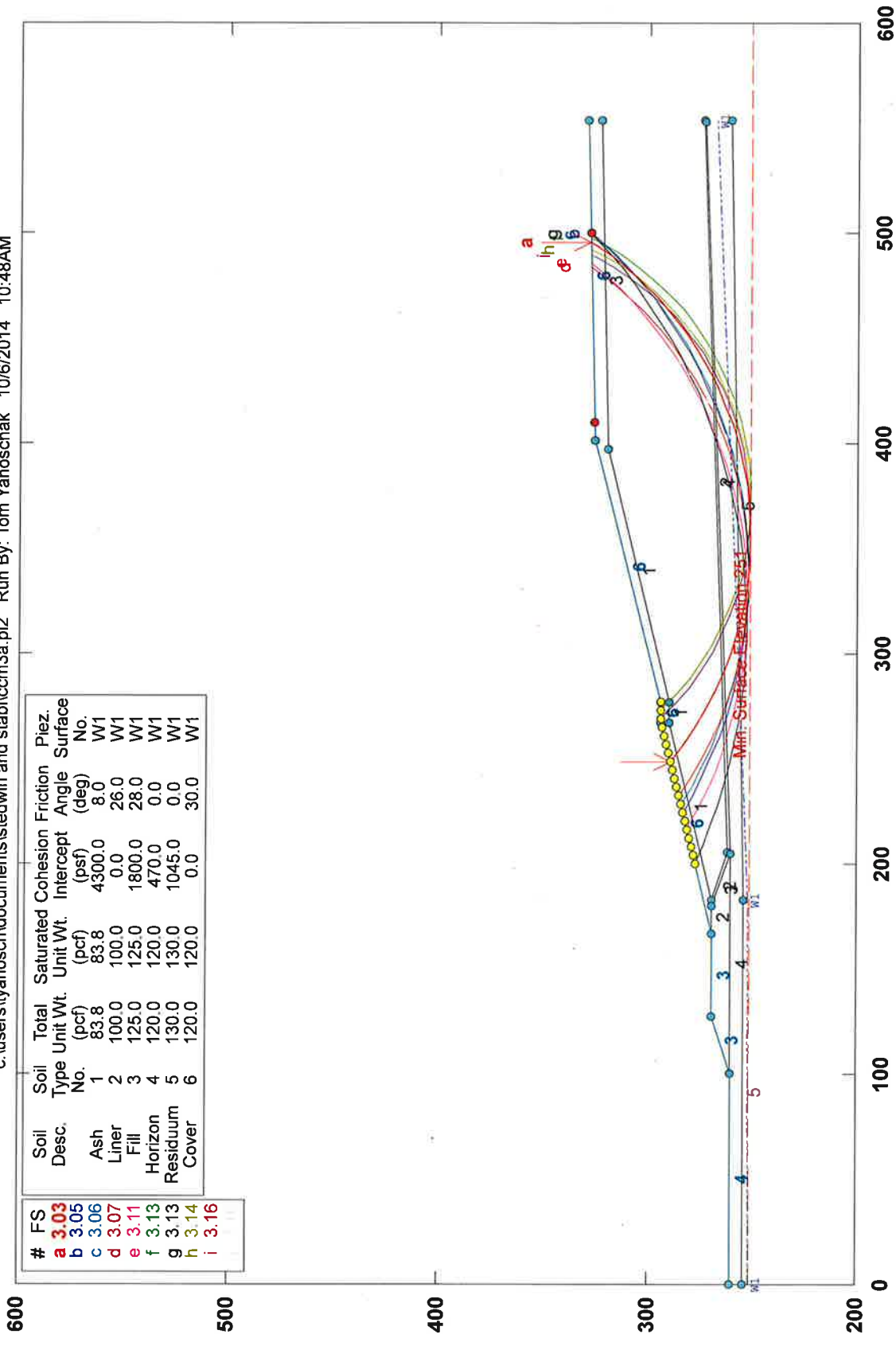

Soil Desc.	Soil Type No.	Total Unit Wt. (pcf)	Saturated Unit Wt. (pcf)	Cohesion (psf)	Friction Angle (deg)	Piez. Surface No.
Ash	1	83.8	83.8	4300.0	8.0	W1
Liner	2	100.0	100.0	0.0	26.0	W1
Fill	3	125.0	125.0	1800.0	28.0	W1
Horizon	4	120.0	120.0	470.0	0.0	W1
Residuuum	5	130.0	130.0	1045.0	0.0	W1
Cover	6	120.0	120.0	0.0	30.0	W1

#	FS
a	3.03
b	3.05
c	3.06
d	3.07
e	3.11
f	3.13
g	3.13
h	3.14
i	3.16

PCSTABL5M/si FSmin=3.03

Safety Factors Are Calculated By The Modified Bishop Method

Charah Colon Mine Structural Fill Ash Slope - Seismic (Total Stress)

c:\users\tyanosch\documents\stedwin and stabil\ccm3as.pl2 Run By: Tom Yanoschak 10/6/2014 10:50AM

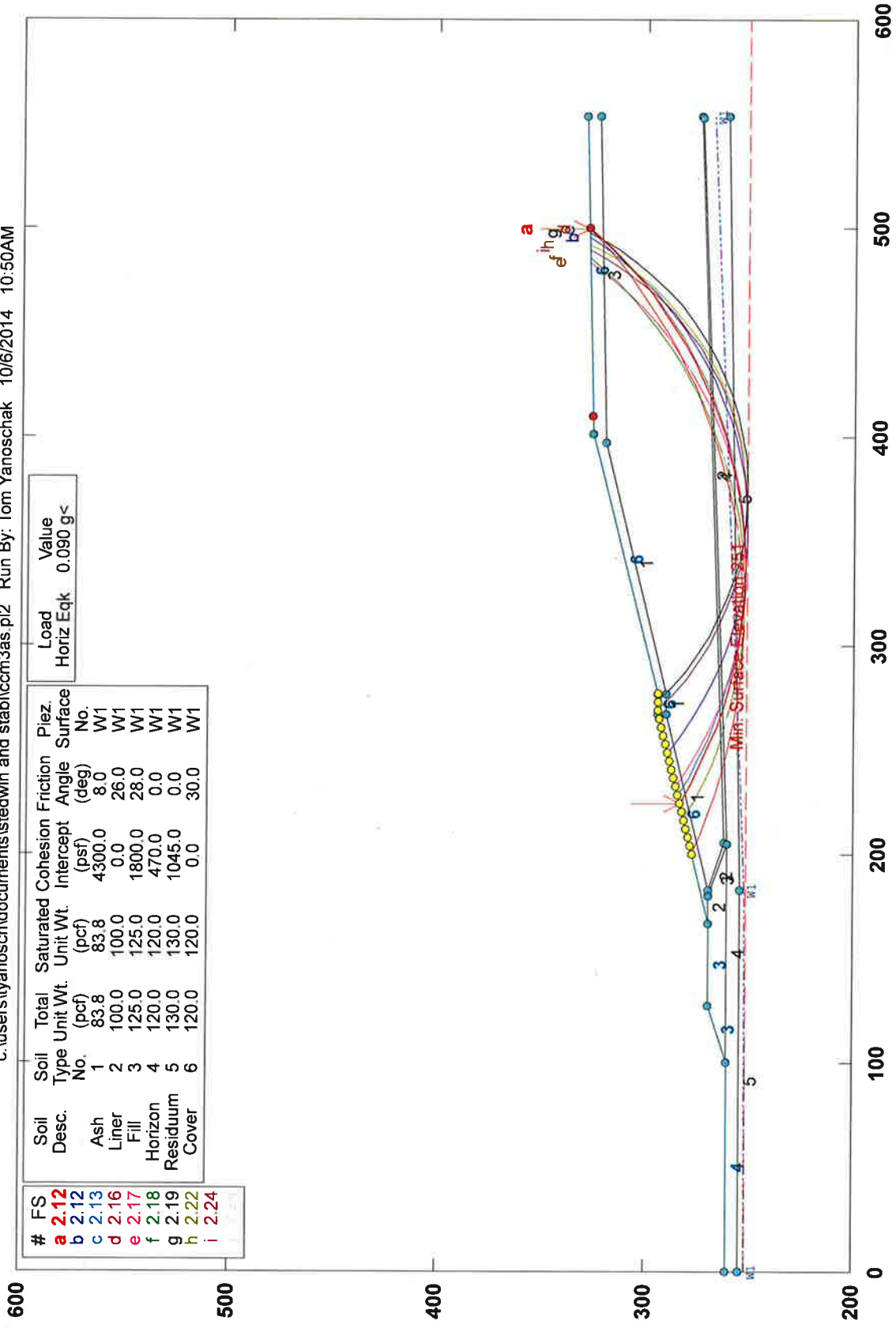

#	FS	Soil Desc.	Soil Type No.	Total Unit Wt. (pcf)	Saturated Unit Wt. (pcf)	Cohesion Intercept (psf)	Friction Angle (deg)	Piez. Surface No.
a	2.12	Ash	1	83.8	83.8	4300.0	8.0	W1
b	2.13	Liner	2	100.0	100.0	0.0	26.0	W1
c	2.16	Fill	3	125.0	125.0	1800.0	28.0	W1
d	2.17	Horizon	4	120.0	120.0	470.0	0.0	W1
e	2.18	Residuum	5	130.0	130.0	1045.0	0.0	W1
f	2.19	Cover	6	120.0	120.0	0.0	30.0	W1
g	2.22							
h	2.24							
i								

Load	Value
Horiz Eqk	0.090 g<

PCSTABL5M/si FSmin=2.12
Safety Factors Are Calculated By The Modified Bishop Method

Charah Colon Mine Structural Fill Ash Slope - Static (Effective Stress)

c:\users\yanosch\documents\stedwin and stab\ccm4a.pl2 Run By: Tom Yanoschak 10/6/2014 10:54AM

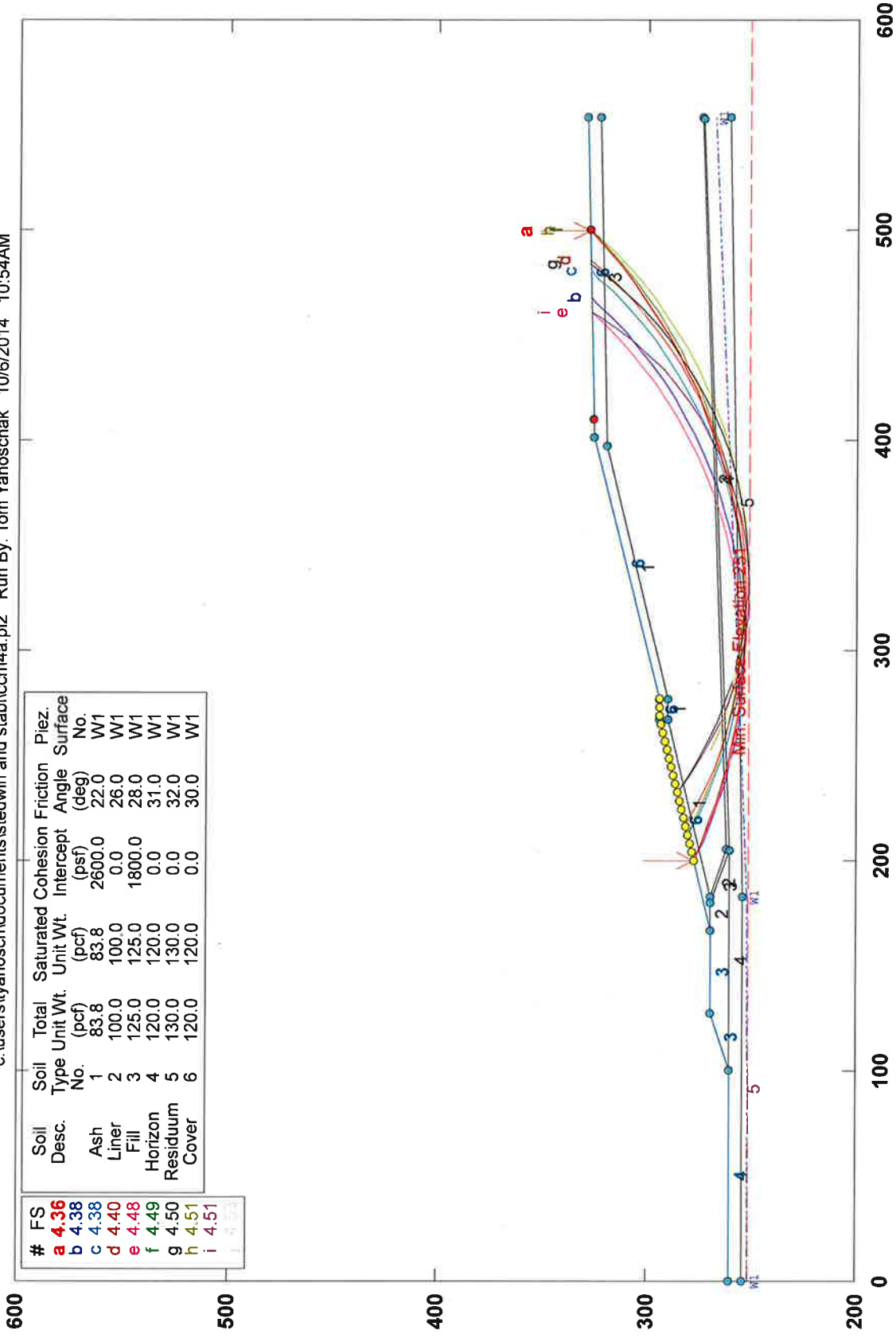

#	FS	Soil Desc.	Soil Type No.	Total Unit Wt. (pcf)	Saturated Unit Wt. (pcf)	Cohesion Intercept (psf)	Friction Angle (deg)	Piez. Surface No.
a	4.36	Ash	1	83.8	83.8	2600.0	22.0	W1
b	4.38	Liner	2	100.0	100.0	0.0	26.0	W1
c	4.38	Fill	3	125.0	125.0	1800.0	28.0	W1
d	4.40	Horizon	4	120.0	120.0	0.0	31.0	W1
e	4.48	Residuum	5	130.0	130.0	0.0	32.0	W1
f	4.49	Cover	6	120.0	120.0	0.0	30.0	W1
g	4.50							
h	4.51							
i	4.51							

PCSTABL5M/si FSmin=4.36

Safety Factors Are Calculated By The Modified Bishop Method

Charah Colon Mine Structural Fill Ash Slope - Seismic (Effective Stress)

c:\users\tyanosch\d\documents\stedwin and stabil\ccm4as.pl2 Run By: Tom Yanoschak 10/6/2014 10:56AM

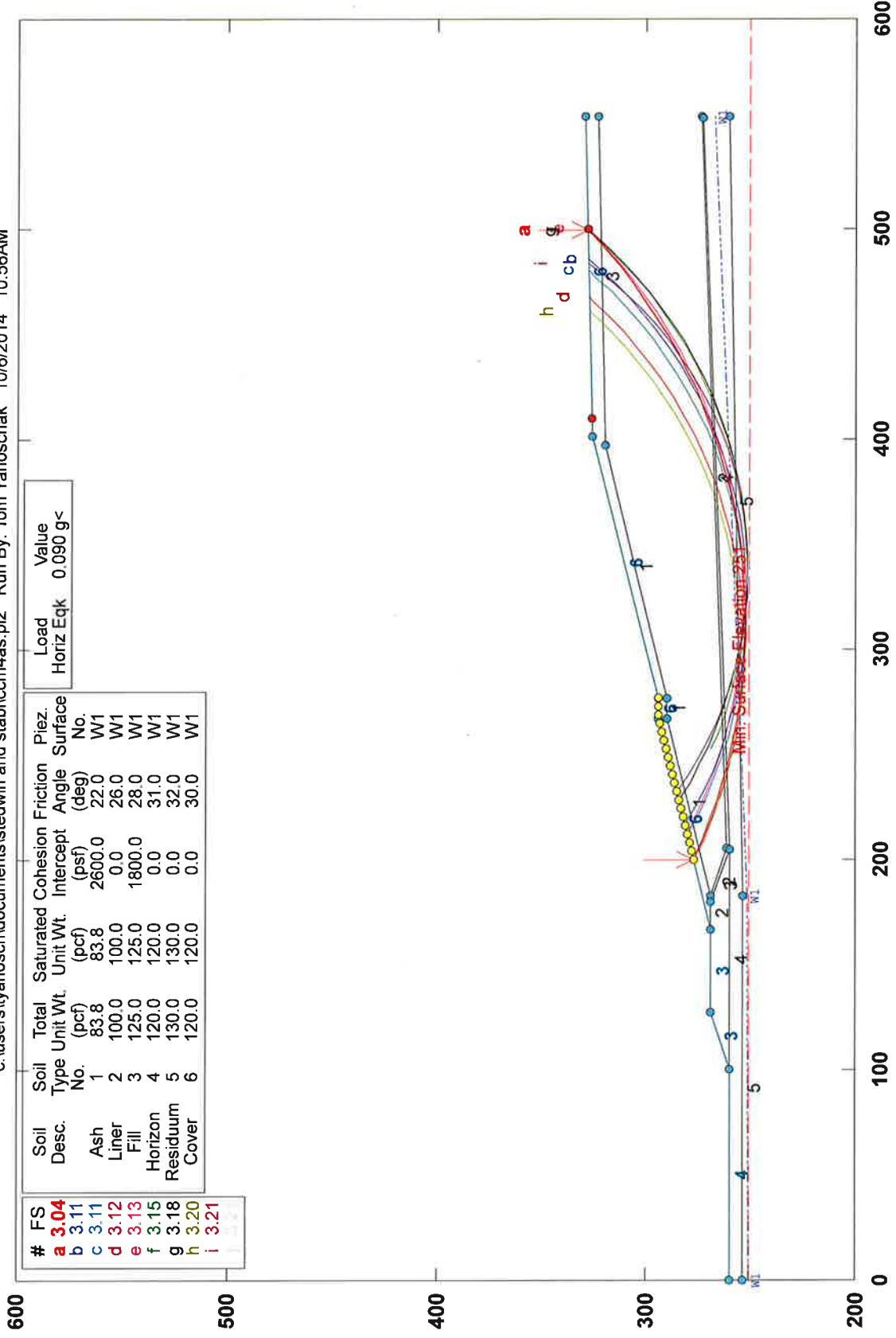

#	FS	Soil Desc.	Soil Type No.	Total Unit Wt. (pcf)	Saturated Unit Wt. (pcf)	Cohesion Intercept (psf)	Friction Angle (deg)	Piez. Surface No.
a	3.04	Ash	1	83.8	83.8	2600.0	22.0	W1
b	3.11	Liner	2	100.0	100.0	0.0	26.0	W1
c	3.11	Fill	3	125.0	125.0	1800.0	28.0	W1
d	3.12	Horizon	4	120.0	120.0	0.0	31.0	W1
e	3.13	Residuum	5	130.0	130.0	0.0	32.0	W1
f	3.15	Cover	6	120.0	120.0	0.0	30.0	W1
g	3.18							
h	3.20							
i	3.21							

Load	Value
Horiz Eqk	0.090 g<

PCSTABL5M/si FSmin=3.04
Safety Factors Are Calculated By The Modified Bishop Method

Charah Colon Mine Structural Fill Sliding Block - Static (Total Stress)

c:\users\tyanosch\documents\stedwin and stabl\ccm5a.pl2 Run By: Tom Yanoschak 10/6/2014 11:05AM

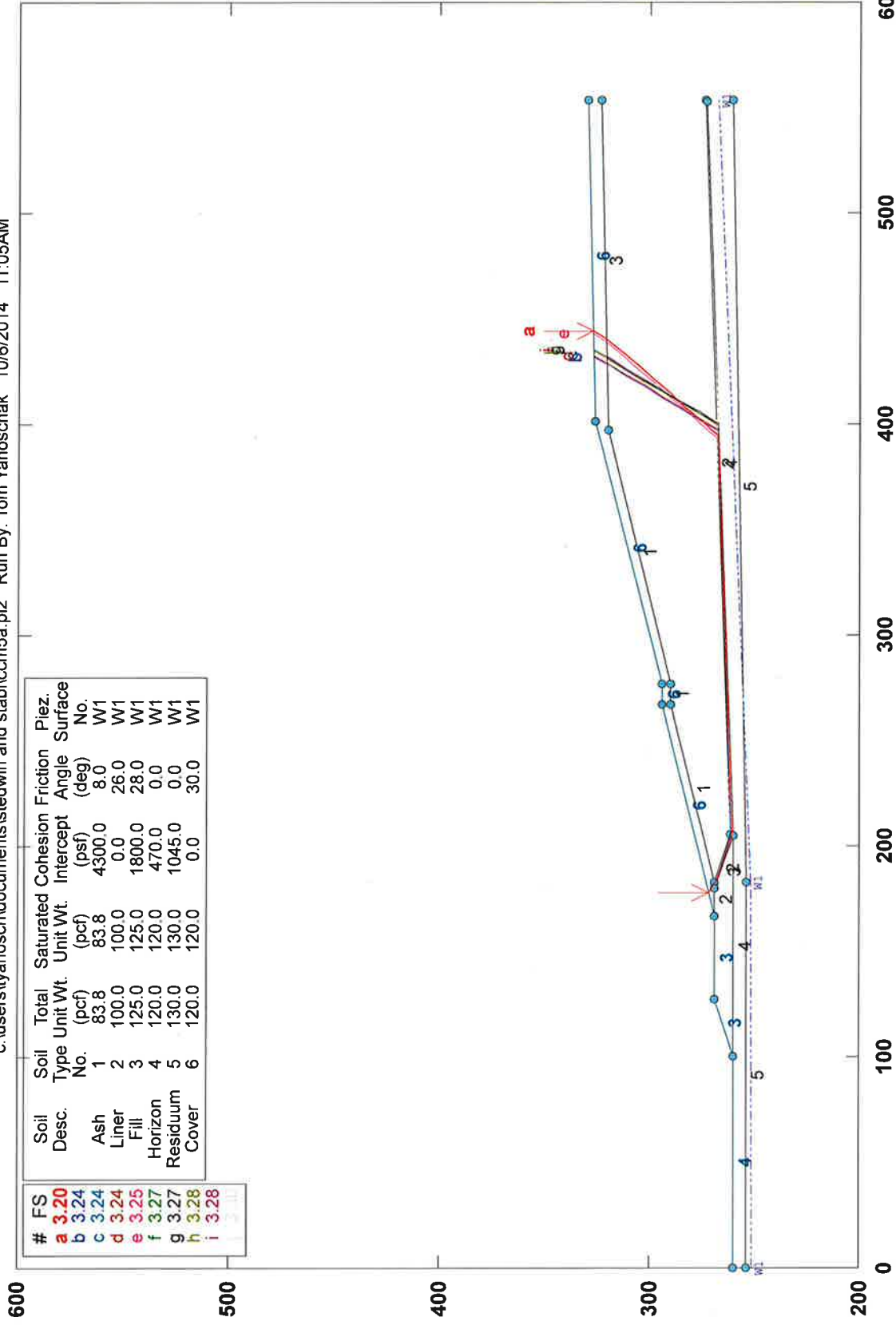

#	FS	Soil Desc.	Soil Type No.	Total Unit Wt. (pcf)	Saturated Unit Wt. (pcf)	Cohesion Intercept (psf)	Friction Angle (deg)	Piez. Surface No.
a	3.20	Ash	1	83.8	83.8	4300.0	8.0	W1
b	3.24	Liner	2	100.0	100.0	0.0	26.0	W1
c	3.24	Fill	3	125.0	125.0	1800.0	28.0	W1
d	3.25	Horizon	4	120.0	120.0	470.0	0.0	W1
e	3.27	Residuum	5	130.0	130.0	1045.0	0.0	W1
f	3.27	Cover	6	120.0	120.0	0.0	30.0	W1
g	3.27							
h	3.28							
i	3.28							

PCSTABL5M/si FSmin=3.20

Safety Factors Are Calculated By The Modified Janbu Method for the case of c & phi both > 0

Charah Colon Mine Structural Fill Sliding Block - Seismic (Total Stress)

c:\users\tyanosch\documents\stedwin and stabilccm5as.pl2 Run By: Tom Yanoschak 10/6/2014 11:06AM

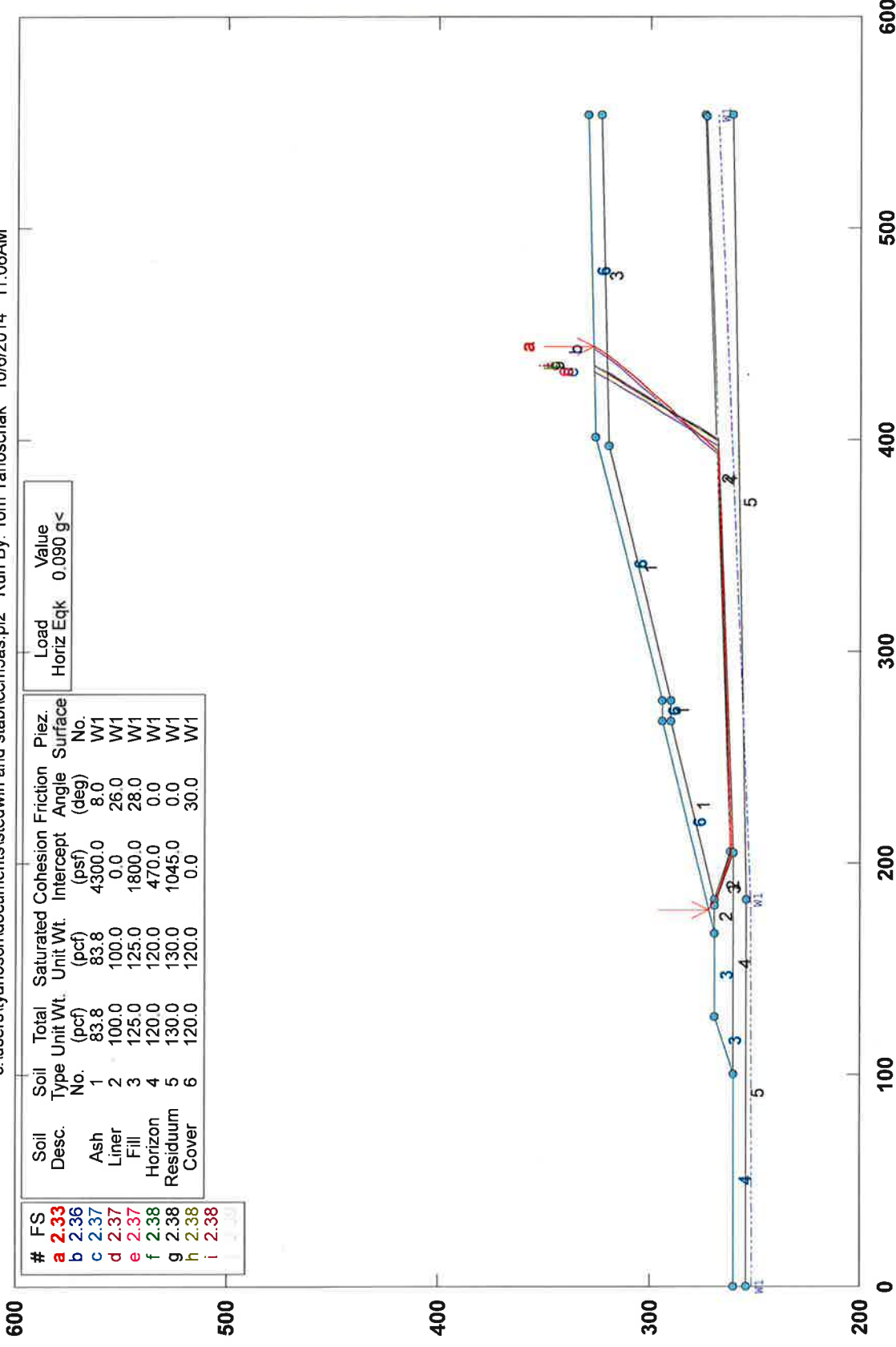

#	FS
a	2.33
b	2.36
c	2.37
d	2.37
e	2.38
f	2.38
g	2.38
h	2.38
i	2.38

Soil Desc.	Soil Type No.	Total Unit Wt. (pcf)	Saturated Unit Wt. (pcf)	Cohesion Intercept (psf)	Friction Angle (deg)	Piez. Surface No.
Ash	1	83.8	83.8	4300.0	8.0	W1
Liner	2	100.0	100.0	0.0	26.0	W1
Fill	3	125.0	125.0	1800.0	28.0	W1
Horizon	4	120.0	120.0	470.0	0.0	W1
Residuum	5	130.0	130.0	1045.0	0.0	W1
Cover	6	120.0	120.0	0.0	30.0	W1

Load	Value
Horiz Eqk	0.090 g<

PCSTABL5M/si FSmin=2.33

Safety Factors Are Calculated By The Modified Janbu Method for the case of c & phi both > 0

Charah Colon Mine Structural Fill Sliding Block - Static (Effectiv Stress)

c:\users\tyanosch\documents\istedwin and stablccr6a.pl2 Run By: Tom Yanoschak 10/6/2014 11:09AM

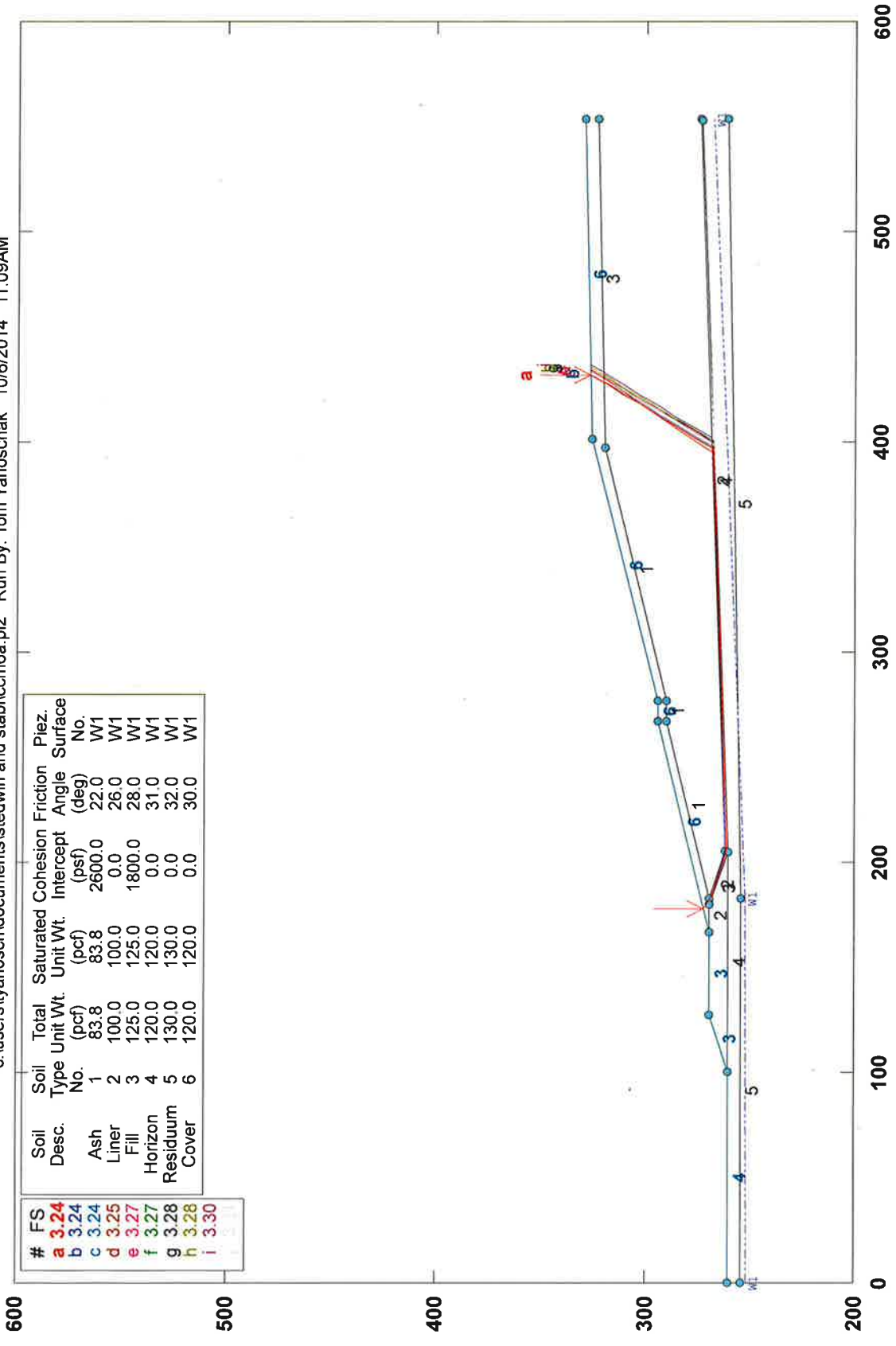

#	FS	Soil Desc.	Soil Type No.	Total Unit Wt. (pcf)	Saturated Unit Wt. (pcf)	Cohesion Intercept (psf)	Friction Angle (deg)	Piez. Surface No.
a	3.24	Ash	1	83.8	83.8	2600.0	22.0	W1
b	3.24	Liner	2	100.0	100.0	0.0	26.0	W1
c	3.24	Fill	3	125.0	125.0	1800.0	28.0	W1
d	3.25	Horizon	4	120.0	120.0	0.0	31.0	W1
e	3.27	Residuum	5	130.0	130.0	0.0	32.0	W1
f	3.27	Cover	6	120.0	120.0	0.0	30.0	W1
g	3.28							
h	3.28							
i	3.30							

PCSTABL5M/si FSmin=3.24

Safety Factors Are Calculated By The Modified Janbu Method for the case of c & phi both > 0

Charah Colon Mine Structural Fill Sliding Block - Seismi (Effectiv Stress)

c:\users\tyanosch\documents\stedwin and stabl\ccmfas.pl2 Run By: Tom Yanoschak 10/6/2014 11:11AM

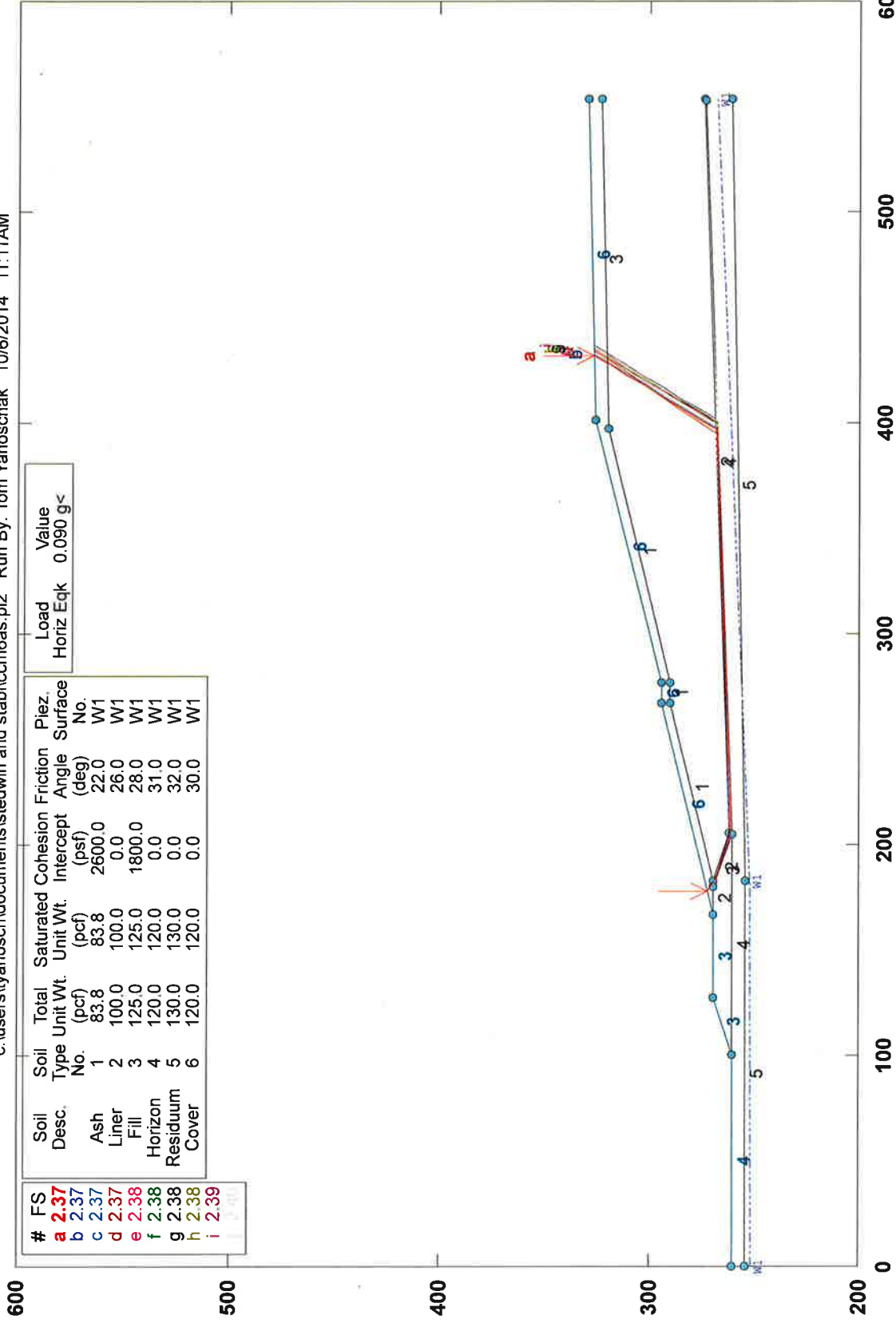

Load	Value
Horiz Eqk	0.090 g<

Soil Desc.	Soil Type No.	Total Unit Wt. (pcf)	Saturated Unit Wt. (pcf)	Cohesion Intercept (psf)	Friction Angle (deg)	Piez. Surface No.
Ash	1	83.8	83.8	2600.0	22.0	W1
Liner	2	100.0	100.0	0.0	26.0	W1
Fill	3	125.0	125.0	1800.0	28.0	W1
Horizon	4	120.0	120.0	0.0	31.0	W1
Residuum	5	130.0	130.0	0.0	32.0	W1
Cover	6	120.0	120.0	0.0	30.0	W1

#	FS
a	2.37
b	2.37
c	2.37
d	2.38
e	2.38
f	2.38
g	2.38
h	2.38
i	2.39

PCSTABL5M/si FSmin=2.37

Safety Factors Are Calculated By The Modified Janbu Method for the case of c & phi both > 0

Charah Colon Mine Structural Fill Sliding Block - Static (Min Liner Phi)

c:\users\tyanosch\d\documents\stedwin and stablccm7a.pl2 Run By: Tom Yanoschak 10/6/2014 11:16AM

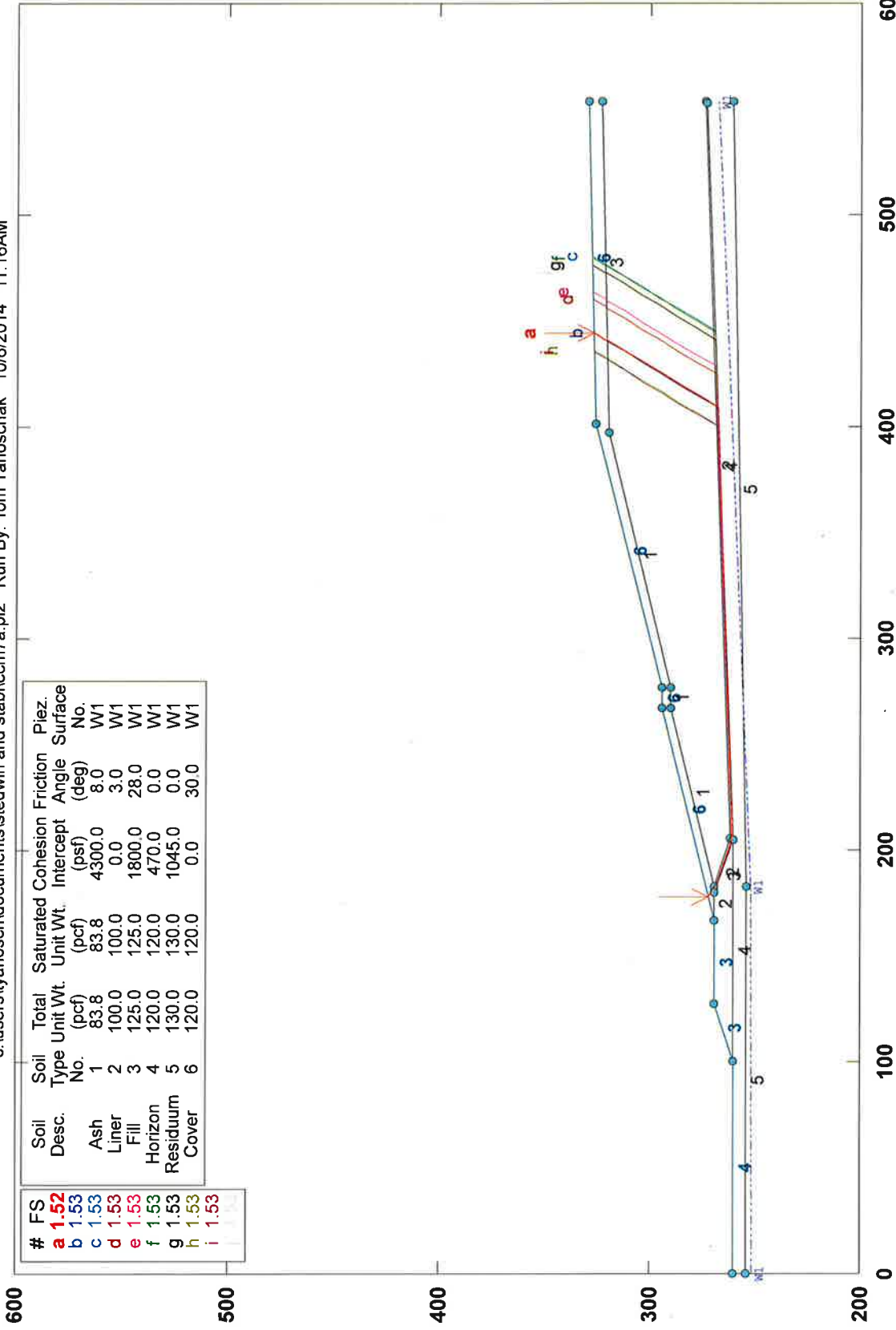

#	FS	Soil Desc.	Soil Type No.	Total Unit Wt. (pcf)	Saturated Unit Wt. (pcf)	Cohesion Intercept (psf)	Friction Angle (deg)	Piez. Surface No.
a	1.52	Ash	1	83.8	83.8	4300.0	8.0	W1
b	1.53	Liner	2	100.0	100.0	0.0	3.0	W1
c	1.53	Fill	3	125.0	125.0	1800.0	28.0	W1
d	1.53	Horizon	4	120.0	120.0	470.0	0.0	W1
e	1.53	Residuuum	5	130.0	130.0	1045.0	0.0	W1
f	1.53	Cover	6	120.0	120.0	0.0	30.0	W1

PCSTABL5M/si FSmin=1.52

Safety Factors Are Calculated By The Modified Janbu Method for the case of c & phi both > 0

Charah Colon Mine Structural Fill Sliding Block - Seismic (Min Liner Phi)

c:\users\tyanosch\documents\stedwin and stabil\ccm8a.pl2 Run By: Tom Yanoschak 10/6/2014 11:19AM

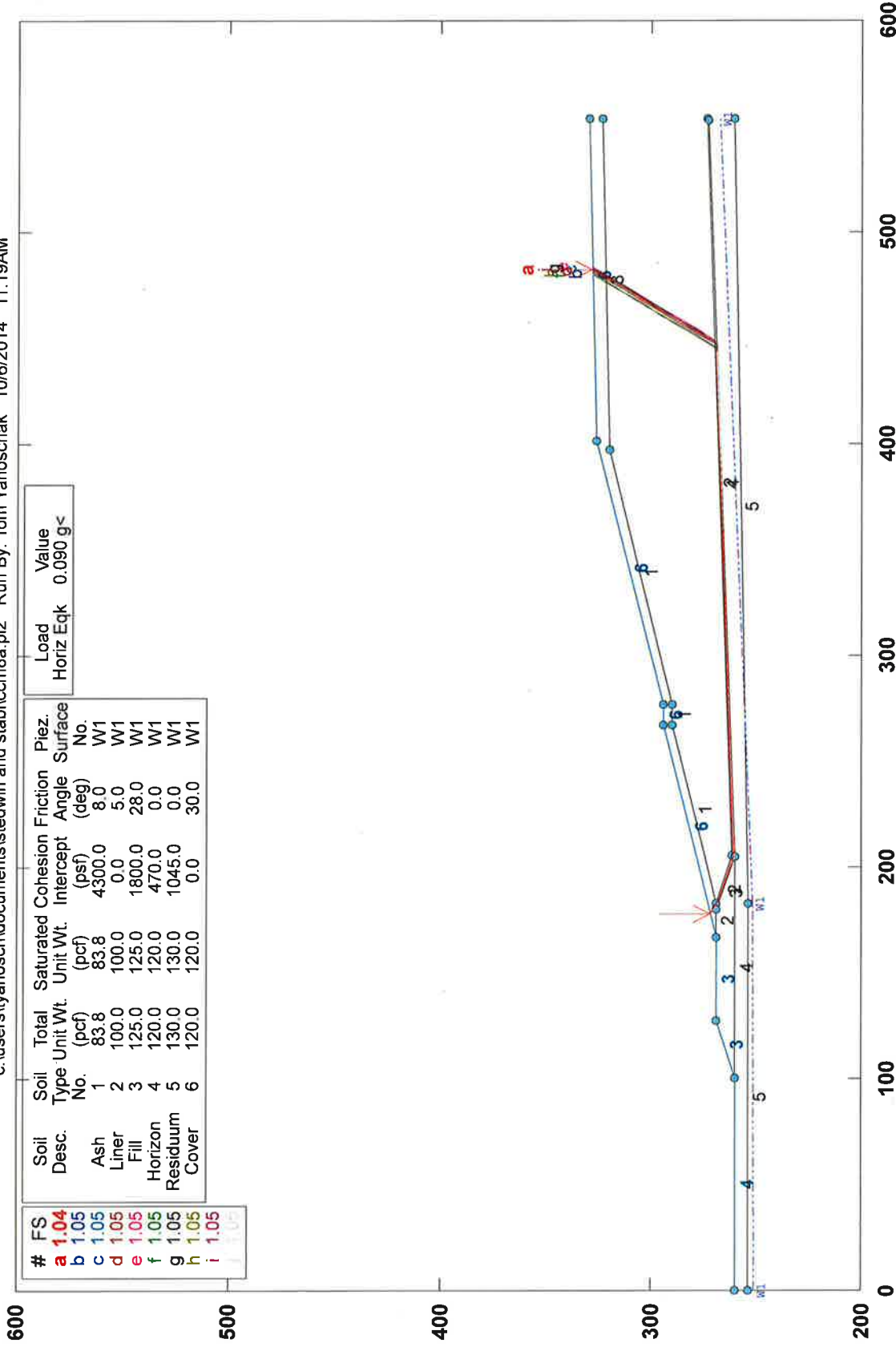

Soil Desc.	Soil Type No.	Total Unit Wt. (pcf)	Saturated Unit Wt. (pcf)	Cohesion Intercept (psf)	Friction Angle (deg)	Piez. Surface No.
Ash	1	83.8	83.8	4300.0	8.0	W1
Liner	2	100.0	100.0	0.0	5.0	W1
Fill	3	125.0	125.0	1800.0	28.0	W1
Horizon	4	120.0	120.0	470.0	0.0	W1
Residuum	5	130.0	130.0	1045.0	0.0	W1
Cover	6	120.0	120.0	0.0	30.0	W1

#	FS
a	1.04
b	1.05
c	1.05
d	1.05
e	1.05
f	1.05
g	1.05
h	1.05
i	1.05

Load	Value
Horiz Eqk	0.090 g<

PCSTABL5M/si FSmin=1.04

Safety Factors Are Calculated By The Modified Janbu Method for the case of c & phi both > 0



Buxton Environmental, Inc.
 Consulting Services
 1101 South Blvd., Suite 101
 Charlotte, North Carolina 28203
 Ph (704) 344-1450 Fax (704) 344-1451
 buxtonenv@bellsouth.net

Boring Log, PZ-1

(Page 1 of 1)

Sanford Mine Reclamation Site
 1303 Brickyard Road
 Sanford, North Carolina

Date Started: 7/15/14
 Date Completed: 7/15/14
 Drilling Company: Red Dog Drilling
 Drillers Name: Mark Seiler
 NC Driller Certification: 2789A

Logged By: Ross Klingman, P.G.
 Drilling Method: HSA; CME-45C
 Top-of-Casing Elev.: 269.36'(Lawrence Survey)
 Ground Surface Elev.: 266.78'(Lawrence Survey)
 Natural, Cut, Fill Grade: Fill (road bed)

Water Levels

▼ 1 Hour = 18.17' bgs
 ▼ 24 Hours = 8.89' bgs

Sample Type

SS = Split Spoon
 ST = Shelby Tube
 RC = Rock Core
 BAG = Bag Sample

Lithologic Description

Well: PZ-1
 TOC Elev.: 269.36
 Cover

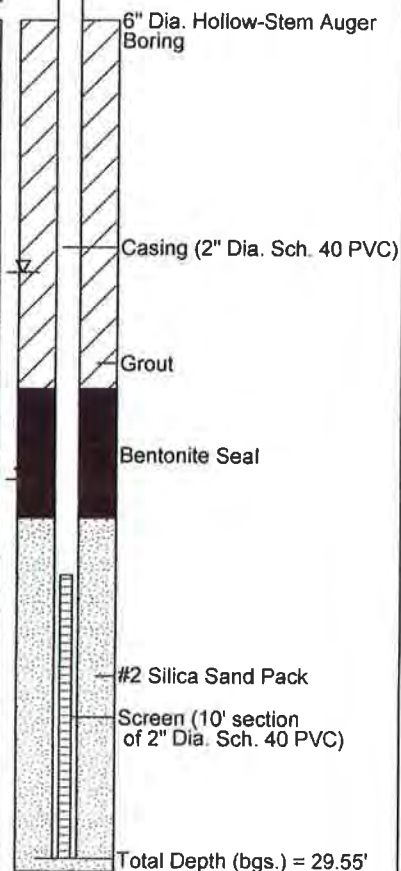

Fill CL
 CL
 PWR

Depth (feet bgs.)	Elevation (feet asl.)	Blow Count/6-inches	Sampler Type	Recovery (in.)	Lithologic Description
0	266.78	33/4 55	SS	14	dry; very hard; red (2.5YR 4/6) with brown mottles; fine to coarse sandy silty clay with brick gravel fragments; cohesive; medium plasticity; Fill CL
5	261.78	5/6 16	SS	16	moist; very stiff; reddish brown (2.5 YR 4/3) with orange and yellow mottles and black vertical stringers; quartz gravelly silty clay; high plasticity; cohesive; Fill CL
10	256.78	7/8 13	SS	18	moist; stiff; reddish yellow (5YR 6/6) with white and rust mottles and stringers; silty clay; medium plasticity; cohesive; Fill CL
15	251.78	17/4"	SS	10	moist; very hard; yellowish red (5YR 4/6) with black stringers; horizontal fissle; very fine mica sandy silty clay with large quartz gravel; low plasticity; cohesive; Partially Weathered Rock
20	246.78	7/4"	SS, BAG	8	dry; very compact; red (2.5YR 4/6); clayey silty medium sand; no plasticity or cohesion; Partially Weathered Rock; (Lab Results: PZ-1 Bag (19-20'); USCS=SC; Gravel=12.1%; Sand=58.9%; Silt=22.7%; Clay=6.3%; Effective Porosity=26%; Atterberg Limits: PL=17, LL=29, PI=12)
25	241.78	41/50/1"	SS, BAG	10	dry; very compact; weak red (2.5YR 4/6) with white mottles and specks; horizontal fissle; quartz gravelly clayey silt; low plasticity; cohesive; Partially Weathered Rock; (Lab Results: PZ-1 Bag (24-25'); USCS=CL; Sand=38.9%; Silt=47.1%; Clay=14.0%; Effective Porosity=15%; Atterberg Limits: PL=17, LL=30, PI=13)
30	236.78	50/5"	SS	4	wet; weak red (10R 4/4); weathered mudstone with quartz and phyllite gravel; Partially Weathered Rock
Auger Refusal @ 30'					
35	231.78				
40	226.78				
45					



Buxton Environmental, Inc.
 Consulting Services
 1101 South Blvd., Suite 101
 Charlotte, North Carolina 28203
 Ph (704) 344-1450 Fax (704) 344-1451
 buxtonenv@bellsouth.net

Boring Log, PZ-2s and 2

(Page 1 of 1)

Sanford Mine Reclamation Site
 1303 Brickyard Road
 Sanford, North Carolina

Date Started: : 7/15/14
 Date Completed: : 7/16/14
 Drilling Company: : Red Dog Drilling
 Drillers Name: : Mark Seiler
 NC Driller Certification: : 2789A

Logged By: : Ross Klingman, P.G.
 Drilling Method: : HSA; CME-45C
 Top-of-Casing Elev.: : 276.93/276.84'
 Ground Surface Elev.: : 274.31'
 Natural, Cut, Fill Grade: : Fill (road bed)

Depth (feet bgs.)	Elevation (feet asl.)	Blow Count/6-inches	Sampler Type	Recovery (in.)	Water Levels	Sample Type
					▼ 1 Hour = dry/16.10' bgs ▽ 24 Hours = dry/11.84' bgs	SS = Split Spoon ST = Shelby Tube RC = Rock Core BAG = Bag Sample
Lithologic Description						

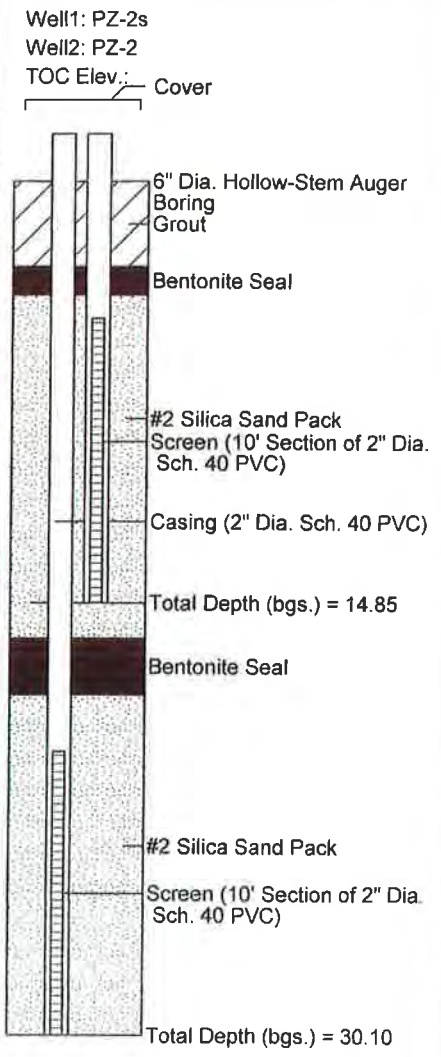

Fill
 MLR
 CL
 PWR
 CL
 PWR

0	274.31	17 24	SS	21	dry; compact; reddish yellow (7.5YR 6/8); horizontal fissile; clayey silt with gravel and brick fragments; no plasticity or cohesion; Fill	
5	269.31	14 18	SS	20	moist; very stiff; brown (10YR 5/3) with gray and white mottles; quartz gravelly fine sandy clayey silt with roots and organic odor; low plasticity; cohesive; Fill	
10	264.31	4 6	SS,ST	20,24	moist; stiff; brownish yellow (10YR 6/6) with light gray and light orange mottles; coarse quartz sandy clayey silt; low plasticity; cohesive; Flood Plain; (Lab Results: PZ-2 UD (9-11'); USCS=CH; Gravel=2.1%; Sand=15.3%; Silt= 40.2%; Clay=42.4%; Specific Gravity=2.66' Hydraulic Conductivity= 6.23 x 10-5 cm/sec; Total Porosity=40.7%; Effective Porosity=2%; Atterberg Limits: PL=25, LL=50; PI=25)	
15	259.31	30 50/4"	SS	12	dry; very hard; yellowish red (5YR 4/6) with black manganese horizontal planes between fissile layers; clayey silt; low plasticity; cohesive; Partially Weathered Rock	
20	254.31	13 20	SS	16	moist; hard; red (2.5YR 5/6) with yellow stringers; silty clay; low plasticity; cohesive; Residuum	
25	249.31	26 30	SS	18	moist; hard; reddish brown (2.5YR 5/4) with light green gray and black stringers; horizontal fissile; fine sandy clayey silt; low plasticity; cohesive; Residuum	
30	244.31	17 22 50/2"	SS,BAG	14	wet; very hard; red (2.5YR 4/8); silty clay; low plasticity; cohesive; Partially Weathered Rock; (Lab Results: PZ-2 Bag (29-30.5'); USCS=CL; Sand=2.2%; Silt=70.7%; Clay=27.1%; Effective Porosity=4; Atterberg Limits= PL=22, LL=43, PI=21)	

Auger Refusal @ 30.5'

35	239.31					
40	234.31					
45						



Buxton Environmental, Inc.
 Consulting Services
 1101 South Blvd., Suite 101
 Charlotte, North Carolina 28203
 Ph (704) 344-1450 Fax (704) 344-1451
 buxtonenv@bellsouth.net

Boring Log, PZ-3s and 3

(Page 1 of 1)

Sanford Mine Reclamation Site
 1303 Brickyard Road
 Sanford, North Carolina

Date Started: : 7/16/14
 Date Completed: : 7/16/14
 Drilling Company: : Red Dog Drilling
 Drillers Name: : Mark Seiler
 NC Driller Certification: : 2789A

Logged By: : Ross Klingman, P.G.
 Drilling Method: : HSA; CME-45C
 Top-of-Casing Elev.: : 299.12/299.29'
 Ground Surface Elev.: : 296.20'
 Natural, Cut, Fill Grade: : slight cut

Depth (feet bgs.)	Elevation (feet asl.)	Blow Count/6-inches	Sampler Type	Recovery (in.)	Water Levels	Sample Type
					▼ 1 Hour = dry/36.11' bgs ▽ 24 Hours = dry/30.91' bgs	SS = Split Spoon ST = Shelby Tube RC = Rock Core BAG = Bag Sample

Well1: PZ-3s
 Well2: PZ-3
 TOC Elev.: Cover

Lithologic Description

CL
 MLT
 PWR

0	296.2	4 80	SS,ST	16,24	moist; stiff; yellowish red (5YR 5/6) with light gray and orange yellow mottled; fine to coarse sandy gravelly clayey silt; low plasticity; cohesive; Soil Horizon; (Lab Results: PZ-3 UD (0-2'); USCS=CL; Sand=6.7%; Silt=52.8%; Clay=40.5%; Specific Gravity=2.67; Hydraulic Conductivity=2.42 x 10 ⁻⁶ cm/sec; Total Porosity=39.3%; Effectuve Porosity=2%; Atterberg Limits: PL=27, LL=48, PI=21)
5	291.2	8 11	SS	14	moist; very stiff; red (2.5YR 4/6) with white and brown specks; clayey fine to coarse sandy and gravelly silt; no plasticity; cohesive; Residuuum
10	286.2	7 16	SS	14	dry; hard; reddish brown (2.5YR 4/6) with light orange and maroon mottles; clayey silt; no plasticity; cohesive; Residuuum
15	281.2	15 44 50/3"	SS	16	moist; very hard; red (10R 5/6) with maroon mottles and vertical manganese fracture planes; clayey silt; no plasticity; cohesive; Partially Weathered Rock
20	276.2	50/6"	SS	7	dry; very hard; reddish brown (2.5YR 5/4) with olive green and white specks; fine to medium sandy silt with rock fragments; no plasticity; cohesive; Partially Weathered Rock
25	271.2	50/5"	SS	9	dry; very compact; reddish brown (2.5YR 5/4) with white and green specks; medium horizontal fissle; silty fine to coarse sand with gravel; no plasticity or cohesion; Partially Weathered Rock
30	266.2	50/2"	SS	5	dry; very hard; weak red (10R 5/3); highly horizontal fissle; fine mica sandy silt; no plasticity; cohesive; Partially Weathered Rock
35	261.2	50/5"	SS,BAG	6	moist; weak red (10R 4/3) with green, yellow and black specks and mottles; slightly clayey silty fine to coarse sand with phyllite gravel; no plasticity or cohesion; Partially Weathered Rock; (Lab Results: PZ-3 Bag (34-34.5'); USCS=SM; Gravel=12.8%; Sand=59.7%; Silt and Clay=27.5%; Effective Porosity=30%)

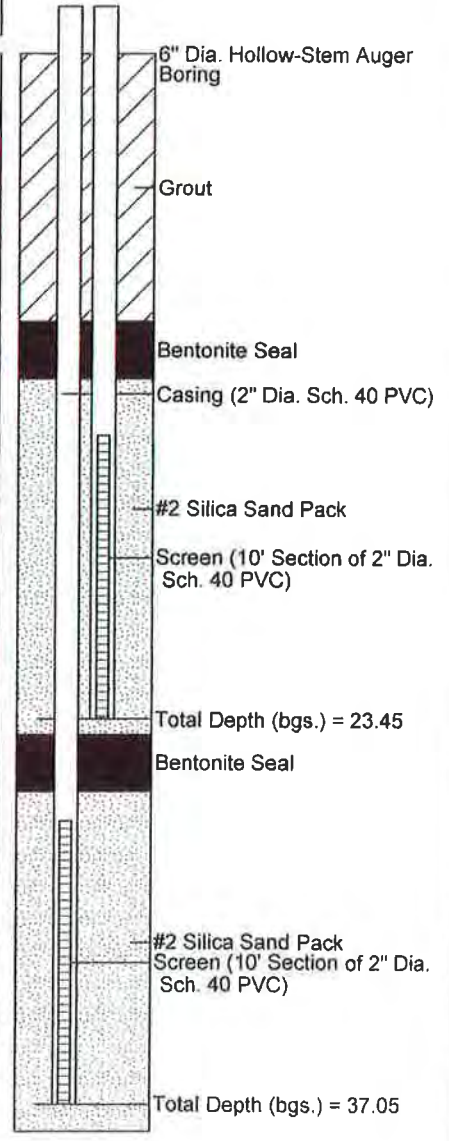

Auger Refual @ 38'

45



Buxton Environmental, Inc.
 Consulting Services
 1101 South Blvd., Suite 101
 Charlotte, North Carolina 28203
 Ph (704) 344-1450 Fax (704) 344-1451
 buxtonenv@bellsouth.net

Boring Log, PZ-4

(Page 1 of 1)

Sanford Mine Reclamation Site
 1303 Brickyard Road
 Sanford, North Carolina

Date Started: 7/16/14
 Date Completed: 7/16/14
 Drilling Company: Red Dog Drilling
 Drillers Name: Mark Seiler
 NC Driller Certification: 2789A

Logged By: Ross Klingman, P.G.
 Drilling Method: HSA; CME-45C
 Top-of-Casing Elev.: 299.50'(Lawrence Survey)
 Ground Surface Elev.: 296.82'(Lawrence Survey)
 Natural, Cut, Fill Grade: slight cut

Depth (feet bgs.)	Elevation (feet asl.)	Blow Count/6-inches	Sampler Type	Recovery (in.)	Water Levels	Sample Type	Lithologic Description
					▼ 1 Hour = dry ▽ 24 Hours = 33 22' bgs	SS = Split Spoon ST = Shelby Tube RC = Rock Core BAG = Bag Sample	
0	296.82	10	SS	14			moist; stiff; brownish yellow (10YR 6/8); fine to coarse sandy clayey silt with gravel; low plasticity; cohesive; Soil Horizon <i>MH</i>
5	291.82	11	SS, BAG	16			moist; stiff; brownish yellow (10YR 6/8) with rust mottles; silty clay; low plasticity; cohesive; Soil Horizon; (Lab Results: PZ-4 Bag (4-5.5'); USCS=CH; Sand=3.0%; Silt=50.9%; Clay=46.1%; Effective Porosity=2%; Atterberg Limits: PL=27, LL=60, PI=33) <i>CH</i>
10	286.82	12	SS	18			moist; very stiff; red (2.5YR 4/8) with olive green, rust, light gray and light purple mottled; gravelly clayey silt; no plasticity; cohesive; Residuum <i>MH</i>
15	281.82	27 50/5"	SS	12			dry; very hard; weak red (2.5YR 5/2) with light green specks; medium horizontal fissile; silt; no plasticity; cohesive; Partially Weathered Rock
20	276.82	29 50/3"	SS	12			dry; very hard; weak red (2.5YR 5/2) with white stringers and vertical black manganese fracture planes; silt; no plasticity; cohesive; Partially Weathered Rock
25	271.82	47 50/4"	SS, BAG	15			moist; very hard; red (2.5YR 4/6); highly horizontal fissile; very slightly clayey silt; no plasticity; cohesive; Partially Weathered Rock; (Lab Results: PZ-4 Bag (24-24.5'); USCS=CL; Sand=21.0%; Silt=61.6%; Clay=17.4%; Effective Porosity=11%; Atterberg Limits: PL=16, LL=31, PI=15)
30	266.82	34 50/2"	SS	20			moist; very hard; weak red (10R 4/2) with white, black and yellow specks and stringers; medium horizontal fissile; slightly clayey silt; no plasticity; cohesive; Partially Weathered Rock
35	261.82	50/0"	SS	0			No Recovery
Auger Refusal @ 36.7'							
40	256.82						
45							

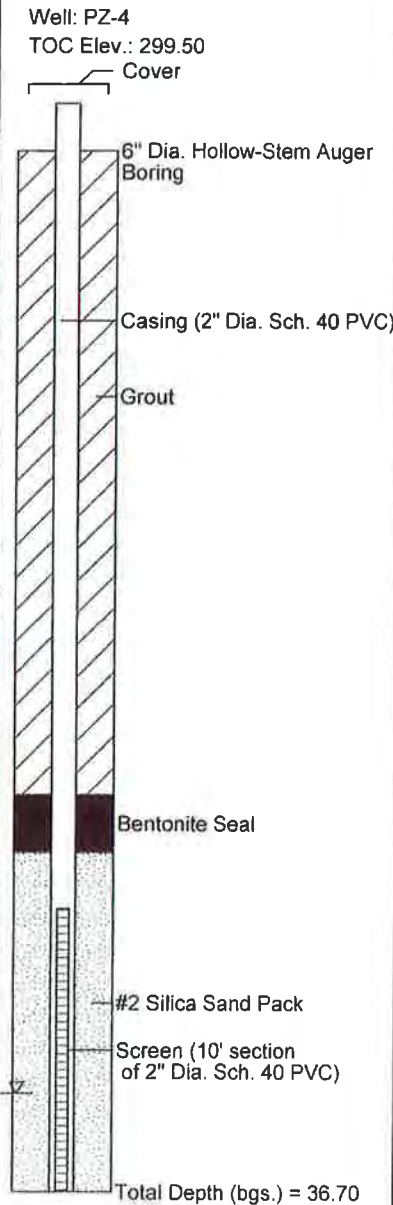

MH

CH

MH

PHR



Buxton Environmental, Inc.
 Consulting Services
 1101 South Blvd., Suite 101
 Charlotte, North Carolina 28203
 Ph (704) 344-1450 Fax (704) 344-1451
 buxtonenv@bellsouth.net

Boring Log, PZ-4D

(Page 1 of 1)

Sanford Mine Reclamation Site
 1303 Brickyard Road
 Sanford, North Carolina

Date Started: 7/16/14
 Date Completed: 7/16/14
 Drilling Company: Geologic Exploration
 Drillers Name: Johnny Burr
 NC Driller Certification: 3098A

Logged By: Ross Klingman, P.G.
 Drilling Method: HSA; Geoprobe 8040DT
 Top-of-Casing Elev.: 299.76'(Lawrence Survey)
 Ground Surface Elev.: 297.25'(Lawrence Survey)
 Natural, Cut, Fill Grade: slight cut

Depth (feet bgs.)	Elevation (feet asl.)	Blow Count/6-inches	Sampler Type	Recovery (in.)	Water Levels	Sample Type	Lithologic Description	Well: PZ-4D TOC Elev.: 299.76
					▼ 1 Hour = dry ▽ 24 Hours = 35.00' bgs	SS = Split Spoon ST = Shelby Tube RC = Rock Core BAG = Bag Sample		
0	297.25						Advance 10" diameter Hollow-Stem Augers from 0-35' See Boring Log PZ-4 for lithologic information from 0-36.5'	
5	292.25							
10	287.25							
15	282.25							
20	277.25							
25	272.25							
30	267.25							
35	262.25						Auger Refusal @ 35'	
40	257.25						Advance 5 5/8" diameter mud-rotary drilling from 35-45', (layered rock and soil from 35-42'; moderately competent rock from 42-45')	
45	252.25						Advance HQ rock core (3 5/8" outer diameter) from 45-55'	
50	247.25						*1st Run from 45-50' (23.5" Recovery; RQD=39.2%; Rock Mass Quality=Poor)	
55	242.25						Upper 9" core (blocky mudstone with healed 80 degree fracture; grading downward to muddy coarse sandstone)	
60	237.25						Lower 14.5" core (muddy sandy conglomerate; consisting of horizontally oriented rounded phyllite discs and rounded quartz gravel)	
65	232.25						*2nd Run (50-55') (45" Recovery; RQD=23.3%; Rock Mass Quality=Very Poor)	
70							Broken conglomerate as above (4" total length); grading downward into blocky mudstone with horizontal fractures every 1.5 to 5" (37.5" total length); grading downward into muddy coarse sandstone (3.5" length total)	



Buxton Environmental, Inc.
 Consulting Services
 1101 South Blvd., Suite 101
 Charlotte, North Carolina 28203
 Ph (704) 344-1450 Fax (704) 344-1451
 buxtonenv@bellsouth.net

Boring Log, PZ-5

(Page 1 of 1)

Sanford Mine Reclamation Site
 1303 Brickyard Road
 Sanford, North Carolina

Date Started: : 7/17/14
 Date Completed: : 7/17/14
 Drilling Company: : Red Dog Drilling
 Drillers Name: : Mark Seiler
 NC Driller Certification: : 2789A

Logged By: : Ross Klingman, P.G.
 Drilling Method: : HSA; CME-45C
 Top-of-Casing Elev.: : 291.66'(Lawrence Survey)
 Ground Surface Elev.: : 289.11'(Lawrence Survey)
 Natural, Cut, Fill Grade: : slight cut

Depth (feet bgs.)	Elevation (feet asl.)	Blow Count/6-inches	Sampler Type	Recovery (in.)	Water Levels ▼ 1 Hour = 33.10' bgs ▽ 24 Hours = 26.06' bgs	Sample Type SS = Split Spoon ST = Shelby Tube RC = Rock Core BAG = Bag Sample	Lithologic Description	Well: PZ-5 TOC Elev.: 291.66 Cover
0	289.11	11	SS	16			moist; stiff; yellow (10YR 7/8) with light orange mottles; silty clay; medium plasticity; cohesive; Soil Horizon	
5	284.11	7	SS	19			wet; stiff; red (2.5YR 5/6) with yellow and light gray mottles; silty clay; low plasticity; cohesive; Soil Horizon	
			ST	24			moist; red (2.5YR 4/6); clayey silt and silty clay; low plasticity; cohesive; Residuuum; (Lab Results: PZ-5 UD (6-8'); USCS=CL; Sand=2.2%; Silt=62.1%; Clay=35.7%; Specific Gravity=2.69; Hydraulic Conductivity=2.43 x 10 ⁻⁷ cm/sec; Total Porosity=30.6%; Effective Porosity=2%; Atterberg Limits: PL=26, LL=48, PI=22)	
10	279.11	54	SS	15			moist; very hard; red (2.5YR 4/6); medium horizontal fissile; clayey silt; low plasticity; cohesive; Residuuum	
15	274.11	63	SS	18			moist; very hard; red (2.5YR 4/6); medium horizontal fissile; clayey silt; low plasticity; cohesive; Residuuum	
20	269.11	50/5"	SS	14			moist; very hard; weak red (10R 4/3) with dark gray mottles; blocky horizontal fissile; silty clay; no plasticity; cohesive; Partially Weathered Rock	
25	264.11	50/6"	SS	14			moist; very hard; red (10R 4/6); highly horizontal fissile; slightly clayey silt; no plasticity; cohesive; Partially Weathered Rock	
30	259.11	50/2"	SS	5			moist; very hard; red (10R 4/6) with gray pods; highly horizontal fissile; slightly clayey silt; no plasticity; cohesive; Partially Weathered Rock	
35	254.11	50/6"	SS, BAG	8			wet; very hard; red (10R 4/6) with gray pods; highly horizontal fissile; slightly clayey silt; no plasticity; cohesive; Partially Weathered Rock; (Lab Results: PZ-5 Bag (34-34.5'); USCS=CL; Sand 13.7%; Silt=73.6; Clay=12.7%; Effective Porosity=8; Atterberg Limits: PL=20, LL=32, PI=12)	
40	249.11							
45								

CL
 Silt
 Mit
 pms



Buxton Environmental, Inc.
 Consulting Services
 1101 South Blvd., Suite 101
 Charlotte, North Carolina 28203
 Ph (704) 344-1450 Fax (704) 344-1451
 buxtonenv@bellsouth.net

Boring Log, PZ-6

Sanford Mine Reclamation Site
 1303 Brickyard Road
 Sanford, North Carolina

Date Started: 7/17/14
 Date Completed: 7/17/14
 Drilling Company: Red Dog Drilling
 Drillers Name: Mark Seiler
 NC Driller Certification: 2789A

Logged By: Ross Klingman, P.G.
 Drilling Method: HSA; CME-45C
 Top-of-Casing Elev.: 286.13'(Lawrence Survey)
 Ground Surface Elev.: 283.48'(Lawrence Survey)
 Natural, Cut, Fill Grade: slight cut

ML

CL

PWR

Depth (feet bgs.)	Elevation (feet asl.)	Blow Count/6-inches	Sampler Type	Recovery (in.)	Water Levels	Sample Type	Lithologic Description
					▼ 1 Hour = dry ▽ 24 Hours = 19 30' bgs	SS = Split Spoon ST = Shelby Tube RC = Rock Core BAG = Bag Sample	
0	283.48	13	SS	10			moist; medium compact; yellow (10YR 7/6); horizontal fissile; silt; no plasticity or cohesion; Soil Horizon <i>ML</i>
5	278.48	8	SS	13			moist; medium; pale yellow (2.5 Y 7/4) with light rust mottles; silty clay with roots; low plasticity; cohesive; Soil Horizon <i>CL</i>
10	273.48	26	SS	20			moist; very stiff; dark reddish gray (2.5YR 4/1) with white and yellow mottles; silty clay; low plasticity; cohesive; Residuum <i>CL</i>
15	268.48	50/5"	SS	24			moist; weak red (10R 4/4); clayey silt; no plasticity; cohesive; Residuum; (Lab Results: PZ-6 UD (10.5-11'); USCS=CL; Sand=11.3%, Silt=72.5%, Clay=16.2%; Specific Gravity=2.68; Hydraulic Conductivity=6.01 x 10-6 cm/sec; Total Porosity=30.7%; Effective Porosity=8%; Atterberg Limits: PL=23, LL=37, PI=14) <i>CL</i>
20	263.48	50/4"	SS BAG	6			moist; very hard; red (2.5YR 4/6); fine to coarse sandy clayey silt with gravel and rock fragments; no plasticity; cohesive; Partially Weathered Rock
25	258.48	50/1"	SS	1			dry; very hard; dark reddish brown (2.5YR 4/1); silty medium to coarse sand with rounded phyllite gravel; no plasticity; cohesive; Partially Weathered Rock; (Lab Results: PZ-6 Bag (19-19.5'); USCS=SC; Sand=59.9%; Silt=27.1%; Clay=13.0%; Effective Porosity=16%; Atterberg Limits: PL=18, LL=33, PI=15)
30	253.48	50/5"	SS	1			moist; very hard; reddish brown (2.5YR 4/4); horizontal fissile; weathered mudstone; Partially Weathered Rock
35	248.48	50/5"	SS	1			dry; very hard; weak red (2.5YR 5/2); horizontal fissile; sandy mudstone; Partially Weathered Rock
40	243.48						dry; very hard; weak red (2.5YR 5/2); weathered silty conglomerate; Partially Weathered Rock

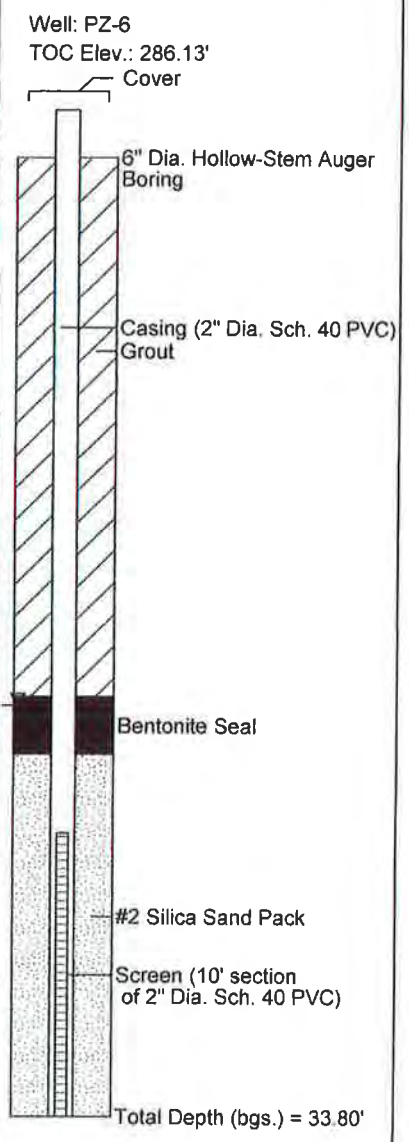



Buxton Environmental, Inc.

Consulting Services
1101 South Blvd., Suite 101
Charlotte, North Carolina 28203
Ph (704) 344-1450 Fax (704) 344-1451
buxtonenv@bellsouth.net

Boring Log, PZ-7

(Page 1 of 1)

Sanford Mine Reclamation Site
1303 Brickyard Road
Sanford, North Carolina

Date Started: 7/17/14
Date Completed: 7/17/14
Drilling Company: Red Dog Drilling
Drillers Name: Mark Seiler
NC Driller Certification: 2789A

Logged By: Ross Klingman, P.G.
Drilling Method: HSA
Top-of-Casing Elev.: 290.57 (Lawrence Survey)
Ground Surface Elev.: 287.92 (Lawrence Survey)
Natural, Cut, Fill Grade: slight cut

Depth (feet bgs.)	Elevation (feet asl.)	Blow Count/6-inches	Sampler Type	Recovery (in.)	Water Levels	Sample Type	Lithologic Description
					▼ 1 Hour = 17.20' bgs ▽ 24 Hours = 6.69' bgs	SS = Split Spoon ST = Shelby Tube RC = Rock Core BAG = Bag Sample	
0	287.92	8	SS	16			moist; medium; light yellowish brown (2.5Y 6/3); fine to coarse sandy clayey silt with roots; no plasticity; cohesive; Soil Horizon MH
5	282.92	20	SS	12			moist; very stiff; reddish brown (%YR 5/4) with light gray mottles; blocky; fine to coarse sandy silty clay; low plasticity; cohesive; Residuum CL
			ST	24			
10	277.92	28	SS	20			moist; reddish brown (5YR 5/4) with light gray mottles; blocky; fine to coarse sandy silty clay; low plasticity; cohesive; Residuum; (Lab Results: PZ-7 UD (6-8'); USCS=CL; Sand=3.2%; Silt=67.5%; Clay=29.3%; Specific Gravity=2.74; Hydraulic Conductivity=1.76 x 10 ⁻⁶ cm/sec; Total Porosity=30.1; Effective Porosity=3; Atterberg Limits: PL=24, LL=40, PI=16) CL
15	272.92	50/6"	SS, BAG	15			moist/wet; very stiff; reddish brown (5YR 5/4) with vertical black manganese planes; silty clay; low plasticity; cohesive; Residuum CL
20	267.92	50/1"	SS	3			moist/wet; very hard; red (2.5YR 5/8); highly horizontal fissile; clayey silt; no plasticity; cohesive; Partially Weathered Rock; (Lab Results: PZ-7 Bag (14-14.5); USCS=CL; Sand=0.4%; Silt=76.8%; Clay=22.8%; Effective Porosity=4%; Atterberg Limits: PL=22, LL=41, PI=19) CL
							wet; very hard; reddish brown (5YR 5/4); highly horizontal fissile; weathered sandy mud stone; Partially Weathered Rock
25	262.92						
30	257.92						
35	252.92						
40	247.92						
45							

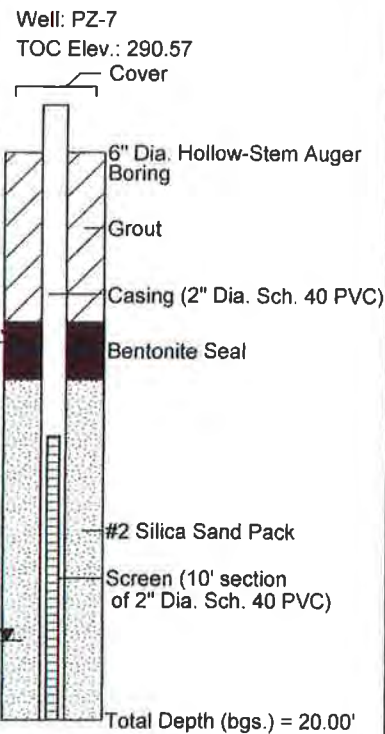

MH

CL

PWR



Buxton Environmental, Inc.
 Consulting Services
 1101 South Blvd., Suite 101
 Charlotte, North Carolina 28203
 Ph (704) 344-1450 Fax (704) 344-1451
 buxtonenv@bellsouth.net

Boring Log, PZ-8

(Page 1 of 1)

Sanford Mine Reclamation Site
 1303 Brickyard Road
 Sanford, North Carolina

Date Started: 7/21/14
 Date Completed: 7/21/14
 Drilling Company: Summit Engineering
 Drillers Name: Robert Cassell
 NC Driller Certification: 4143A

Logged By: Ross Klingman, P.G.
 Drilling Method: HSA; CME-550x
 Top-of-Casing Elev.: 304.85'(Lawrence Survey)
 Ground Surface Elev.: 302.56'(Lawrence Survey)
 Natural, Cut, Fill Grade: slight cut

Depth (feet bgs.)	Elevation (feet asl.)	Blow Count/6-inches	Sampler Type	Recovery (in.)	Water Levels	Sample Type	Lithologic Description
					▼ 1 Hour = dry ▽ 24 Hours = 41.38' bgs	SS = Split Spoon ST = Shelby Tube RC = Rock Core BAG = Bag Sample	
0	302.56	06/4	SS	18			moist; stiff, strong brown (7.5Y 5/8) with white specks; silty clay; medium plasticity; cohesive; Residuuum <i>CL</i>
5	297.56	04/3	SS	14			moist; stiff; red (2.5YR 4/6) with light orange mottles; silty clay; low plasticity; cohesive; Residuuum <i>CL</i>
10	292.56	06/4	SS	15			moist; stiff; red (2.5YR 4/6); silty clay; low plasticity; cohesive; Residuuum <i>CL</i>
15	287.56	10/13	SS,BAG	16			moist; very stiff; red (2.5YR 4/6) with orange mottles and black stringers; silty clay; low plasticity; cohesive; Residuuum; (Lab Results: PZ-8 Bag (13.5-15'); USCS=CL; Sand=3.1%; Silt=68.1%; Clay=28.8%; Effective Porosity=3%; Atterberg Limits: PL=23, LL=39, PI=16) <i>CL</i>
20	282.56	9/13	SS	14			moist; very stiff; red (10R 4/8) with light gray and yellow mottles; clayey quartz and phyllite gravelly silt; no plasticity; cohesive; Residuuum <i>ML</i>
25	277.56	8/13	SS	20			moist; very stiff; red (10R 4/6) with light gray and yellow mottles; clayey quartz and phyllite gravelly silt; no plasticity; cohesive; Residuuum <i>ML</i>
30	272.56	9/27	SS	20			moist; very hard; red (10R 4/8) with maroon mottles; silty clay; low plasticity; cohesive; Residuuum <i>CL</i>
35	267.56	34/50	SS	15			moist; very hard; red (10R 4/8) with maroon mottles; silty clay; low plasticity; cohesive; Residuuum <i>CL</i>
40	262.56	50/5"	SS	12			dry; very compact; weak red (10R 4/4); clayey silty fine to coarse sand; no plasticity or cohesion; Partially Weathered Rock <i>Sc</i>
45		50/5"	SS	10			moist; very hard; red (10R 4/8); highly horizontal fissile; silty clay; low plasticity; cohesive; Partially Weathered Rock <i>CL</i>

Well: PZ-8
 TOC Elev.: 304.85
 Cover

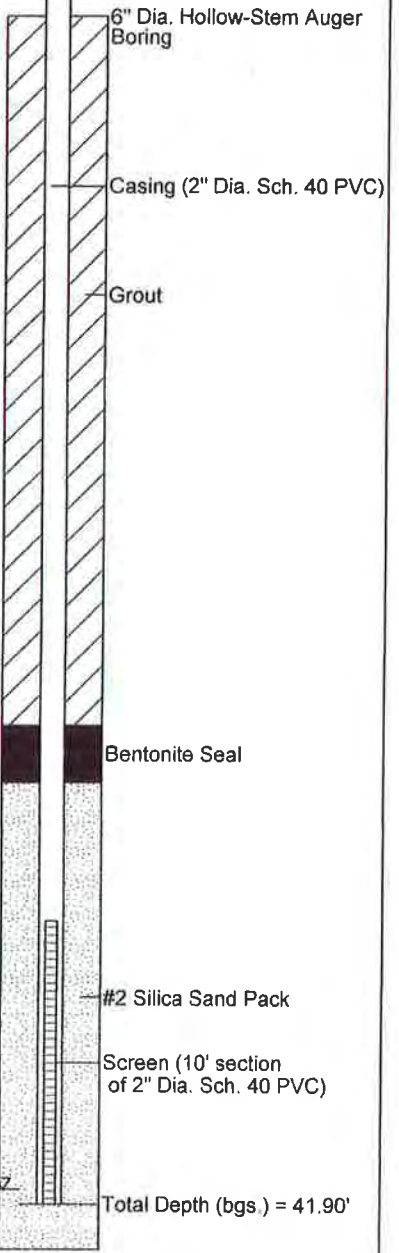

CL

ML

AWR

BL



Buxton Environmental, Inc.
 Consulting Services
 1101 South Blvd., Suite 101
 Charlotte, North Carolina 28203
 Ph (704) 344-1450 Fax (704) 344-1451
 buxtonenv@bellsouth.net

Boring Log, PZ-9s and 9

(Page 1 of 1)

Sanford Mine Reclamation Site
 1303 Brickyard Road
 Sanford, North Carolina

Date Started: 7/21/14
 Date Completed: 7/21/14
 Drilling Company: Summit Engineering
 Drillers Name: Robert Cassell
 NC Driller Certification: 4143A

Logged By: Ross Klingman, P.G.
 Drilling Method: HSA; CME-550x
 Top-of-Casing Elev.: 288.11'/288.11'
 Ground Surface Elev.: 285.74'
 Natural, Cut, Fill Grade: slight cut

Depth (feet bgs.)	Elevation (feet asl.)	Blow Count/6-inches	Sampler Type	Recovery (in.)	Water Levels	Sample Type	Lithologic Description
					▼ 1 Hour = dry/dry ▽ 24 Hours = dry/36.03' bgs	SS = Split Spoon ST = Shelby Tube RC = Rock Core BAG = Bag Sample	
0	285.74	10	SS	16			moist; stiff, yellowish red (5YR 5/6) with rust mottles; silty clay; low plasticity; cohesive; Soil Horizon <i>CL</i>
5	280.74	12	SS	16			moist; stiff; light yellow brown (2.5 Y 6/3) with light orange mottles; silty clay; low plasticity; cohesive; Soil Horizon <i>CL</i>
10	275.74	11	SS	16			moist; stiff; light yellowish brown (2.5Y 6/3) with rust and maroon mottles; silty clay; low plasticity; cohesive; Soil Horizon <i>CL</i>
15	270.74	47	SS,BAG	22			dry; compact; weak red (10R 4/3) with white and gray specks; silty fine to coarse sand with phyllite gravel; no plasticity or plasticity; Residuum; (Lab Results: PZ-9 Bag (13.5-15'); USCS=SC; Gravel=0.4%; Sand=52.2; Silt=35.9; Clay=11.5%; Effective Porosity=17; Atterberg Limits: PL=20, LL=34, PI=14) <i>SC</i>
20	265.74	50/5"	SS	8			dry; very hard; weak red (10R 4/3); highly horizontal fissile; fine sandy silt; no plasticity; cohesive; Partially Weathered Rock
25	260.74	50/4"	SS	8			dry; very compact; weak red (10R 4/3) with white and gray specks; silty fine to coarse sand with phyllite gravel; no plasticity or cohesion; Partially Weathered Rock
30	255.74	50/5"	SS	8			dry; very compact; weak red (10R 4/3) with white and gray specks; silty fine to coarse sand with phyllite gravel; no plasticity or cohesion; Partially Weathered Rock
35	250.74	50/5"	SS	4			dry; very compact; weak red (10R 4/3) with white and gray specks; medium horizontal fissile; silty fine to coarse sand with phyllite gravel; no plasticity or cohesion; Partially Weathered Rock
40	245.74	50/5"	SS	8			dry; very hard; reddish brown (2.5YR 4/4); highly horizontal fissile; weathered mudstone; Partially Weathered Rock

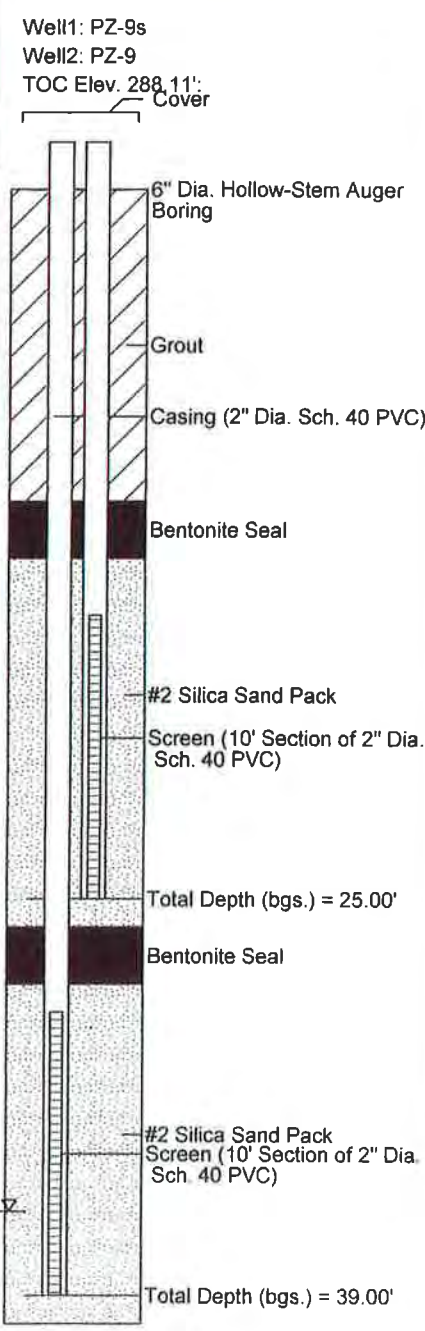

CL
CL
SC
PWR

Basegrade



Buxton Environmental, Inc.

Consulting Services
1101 South Blvd., Suite 101
Charlotte, North Carolina 28203
Ph (704) 344-1450 Fax (704) 344-1451
buxtonenv@bellsouth.net

Boring Log, PZ-10

(Page 1 of 1)

Sanford Mine Reclamation Site
1303 Brickyard Road
Sanford, North Carolina

Date Started: : 7/21/14
Date Completed: : 7/21/14
Drilling Company: : Summit Engineering
Drillers Name: : Robert Cassell
NC Driller Certification: : 4143A

Logged By: : Ross Klingman, P.G.
Drilling Method: : HSA; CME-550x
Top-of-Casing Elev.: : 266.51'(Lawrence Survey)
Ground Surface Elev.: : 263.48'(Lawrence Survey)
Natural, Cut, Fill Grade: : slight cut

Depth (feet bgs.)	Elevation (feet asl.)	Blow Count/6-inches	Sampler Type	Recovery (in.)	Water Levels	Sample Type	Lithologic Description
					▼ 1 Hour = dry ▽ 24 Hours = dry	SS = Split Spoon ST = Shelby Tube RC = Rock Core BAG = Bag Sample	
0	263.48	11	SS	24			moist; stiff; reddish yellow (7.5YR 6/6) with light gray and rust mottles; silty clay; no plasticity; cohesive; Soil Horizon <i>CL</i>
5	258.48	14	SS	14			dry; very stiff; red (2.5YR 4/8) with maroon and light gray mottles; clayey fine sandy silt; no plasticity; cohesive; Residuuum <i>MH</i>
10	253.48	18	SS	12			dry; very hard; red (2.5YR 4/6) with black vertical planes; blocky; silty clay; no plasticity; cohesive; Partially Weathered Rock <i>CL</i>
15	248.48	50/3"	SS	3			dry; very hard; red (2.5YR 4/6) with black vertical planes; highly horizontal fissile; mica sandy silty clay; low plasticity; cohesive; Partially Weathered Rock
20	243.48	50/1"	SS	2			dry; very compact; weak red (10R 5/3); silty fine to coarse sand with quartz and phyllite gravel; no plasticity or cohesion; Partially Weathered Rock
25	238.48	50/6"	SS	12			dry; very hard; red (10R 4/6); highly horizontal fissile; silty clay; no plasticity; cohesive; Partially Weathered Rock
30	233.48	29	SS,BAG	18			moist; very hard; red (10R 4/6) with light orange mottles; highly horizontal fissile; silty clay; no plasticity; cohesive; Residuuum; (Lab Results: PZ-10 Bag (28.5-30'); USCS=CL; Sand=5.7%; Silt=74.0%; Clay=20.3%; Effective Porosity=5%; Atterberg Limits: PL=18, LL=36; PI=18)
35	228.48						
40	223.48						
45							

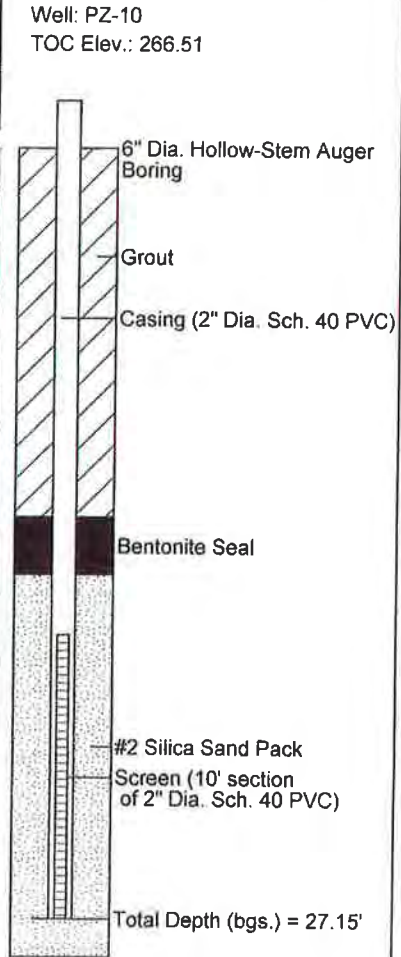

PWP

SH

11
14
27

CL

MH

CL

Total Depth (bgs.) = 27.15'



Buxton Environmental, Inc.
 Consulting Services
 1101 South Blvd., Suite 101
 Charlotte, North Carolina 28203
 Ph (704) 344-1450 Fax (704) 344-1451
 buxtonenv@bellsouth.net

Boring Log, PZ-11

(Page 1 of 1)

Sanford Mine Reclamation Site
 1303 Brickyard Road
 Sanford, North Carolina

Date Started: 7/22/14
 Date Completed: 7/22/14
 Drilling Company: Summit Engineering
 Drillers Name: Robert Cassell
 NC Driller Certification: 4143A

Logged By: Ross Klingman, P.G.
 Drilling Method: HSA; CME-550x
 Top-of-Casing Elev.: 262.30'(Lawrence Survey)
 Ground Surface Elev.: 259.56'(Lawrence Survey)
 Natural, Cut, Fill Grade: natural (drainage bottom)

Depth (feet bgs.)	Elevation (feet asl.)	Blow Count/6-inches	Sampler Type	Recovery (in.)	Water Levels ▼ 1 Hour = dry ▽ 24 Hours = 19.59' bgs	Sample Type SS = Split Spoon ST = Shelby Tube RC = Rock Core BAG = Bag Sample	Lithologic Description	Well: PZ-10 TOC Elev.: 266.51 Cover
0	263.48							8" Dia. Hollow-Stem Auger Boring
		16	SS	20			moist; very stiff; reddish yellow (7.5YR 6/8) with rust and light gray mottles; quartz gravelly fine to coarse sandy clayey silt; no plasticity; cohesive; Soil Horizon	Grout
5	254.58 258.48	5	SS	17			moist; stiff; yellowish red (5YR 4/6) with light gray mottles; fine mica sandy clayey silt; no plasticity; cohesive; Soil Horizon	Casing (2" Dia. Sch. 40 PVC)
		12	ST	5			dry; red (2.5YR 4/6), mica and quartz sandy silt; low plasticity; cohesive; Residuum; (Lab Results: PZ-11 UD (6-6.5'); USCS=SM; Gravel=4.8%; Sand=65.5%; Silt=22.6%; Clay=7.1%; Specific Gravity=2.71; Hydraulic Conductivity=3.86 x 10 ⁻⁶ cm/sec; Total Porosity=19.7%; Effective Porosity=25%)	
10	263.48 249.78	39 50/3"	SS	12			dry; very hard; weak red (10R 4/3); silty fine to coarse sand with gravel; no plasticity; cohesive; Partially Weathered Rock	Bentonite Seal
15	248.48	16 38 50/6"	SS	15			moist; very hard; red (2.5YR 4/6) with black and purple mottles; medium horizontal fissle; silty clay; no plasticity; cohesive; Partially Weathered Rock	#2 Silica Sand Pack
20	243.48	15 36 50/4"	SS	20			moist; very hard; red (2.5YR 4/6) with black and purple mottles; highly horizontal fissle; silty clay; no plasticity; cohesive; Partially Weathered Rock	Screen (10' section of 2" Dia. Sch. 40 PVC)
25	238.48	20 10 8	SS,BAG	16			wet; very stiff; red (2.5YR 4/6) with black and purple mottles; highly horizontal fissle; silty clay with rock and gravel layers; no plasticity; cohesive; Residuum	Total Depth (bgs.) = 24.75'
30	233.48							
35	228.48							
40	223.48							
45								

259.56
 MIT
 85 ft
 PWR

91

514

MIT

SM



Buxton Environmental, Inc.
 Consulting Services
 1101 South Blvd., Suite 101
 Charlotte, North Carolina 28203
 Ph (704) 344-1450 Fax (704) 344-1451
 buxtonenv@bellsouth.net

Boring Log, PZ-12

(Page 1 of 1)

Sanford Mine Reclamation Site
 1303 Brickyard Road
 Sanford, North Carolina

Date Started: : 7/22/14
 Date Completed: : 7/22/14
 Drilling Company: : Summit Engineering
 Drillers Name: : Robert Cassell
 NC Driller Certification: : 4143A

Logged By: : Ross Klingman, P.G.
 Drilling Method: : HSA; CME-550x
 Top-of-Casing Elev.: : 287.15'(Lawrence Survey)
 Ground Surface Elev.: : 284.32'(Lawrence Survey)
 Natural, Cut, Fill Grade: : natural

Depth (feet bgs.)	Elevation (feet asl.)	Blow Count/6-inches	Sampler Type	Recovery (in.)	Water Levels	Sample Type	Lithologic Description	Well: PZ-12 TOC Elev.: 287.15
					▼ 1 Hour = dry ▽ 24 Hours = dry	SS = Split Spoon ST = Shelby Tube RC = Rock Core BAG = Bag Sample		
0	284.32	4	SS	18			moist; medium; yellowish red (5YR 5/8) with brown mottles; clayey, quartz gravelly silt and silty clay; low plasticity; cohesive; Soil Horizon	
5	279.32	13	SS	14			moist; stiff; reddish yellow (7.5YR 6/8) with rust and light gray mottles; silty clay; medium plasticity; cohesive; Soil Horizon	
10	274.32	10	SS	13			moist; stiff; red (2.5YR 4/6) with green and black specks; fine to medium sandy clayey silt; low plasticity; cohesive; Residuum	
15	269.32	5 26 50/4"	SS	15			moist; very hard; red (2.5YR 4/6) with green and black specks; medium horizontal fissile; mica sandy clayey silt; no plasticity; cohesive; Partially Weathered Rock	
20	264.32	12 16	SS,BAG	21			moist; very stiff; red (2.5YR 4/6) with purple mottles; blocky; silty clay; no plasticity; cohesive; Residuum; (Lab Results: PZ-12 Bag (18.5-20'); USCS=CL; Sand=0.7%; Silt=66.5%; Clay=32.8%; Effective Porosity=2%; Atterberg Limits: PL=20, LL=42, PI=22)	
25	259.32	50/3"	SS	8			dry; very hard; red (2.5YR 5/6); horizontal fissile; weathered fine sandy mudstone; Partially Weathered Rock	
30	254.32	50/3"	SS	10			dry; very hard; red (2.5YR 5/6); horizontal fissile; weathered fine sandy mudstone; Partially Weathered Rock	
35	249.32							
40	244.32							
45								

CL

MIT

PWR

7

13

10

5
26
50/4"

12
16

50/3"

50/3"

CL

CL

MIT

8" Dia. Hollow-Stem Auger Boring

Casing (2" Dia. Sch. 40 PVC)

Grout

Bentonite Seal

#2 Silica Sand Pack

Screen (10' section of 2" Dia. Sch. 40 PVC)

Total Depth (bgs.) = 30.60'



Buxton Environmental, Inc.
 Consulting Services
 1101 South Blvd., Suite 101
 Charlotte, North Carolina 28203
 Ph (704) 344-1450 Fax (704) 344-1451
 buxtonenv@bellsouth.net

Boring Log, PZ-13

(Page 1 of 1)

Sanford Mine Reclamation Site
 1303 Brickyard Road
 Sanford, North Carolina

Date Started: 7/22/14
 Date Completed: 7/22/14
 Drilling Company: Summit Engineering
 Drillers Name: Robert Cassell
 NC Driller Certification: 4143A

Logged By: Ross Klingman, P.G.
 Drilling Method: HSA; CME-550x
 Top-of-Casing Elev.: 296.59'(Lawrence Survey)
 Ground Surface Elev.: 293.48'(Lawrence Survey)
 Natural, Cut, Fill Grade: natural

Depth (feet bgs.)	Elevation (feet asl.)	Blow Count/6-inches	Sampler Type	Recovery (in.)	Water Levels	Sample Type	Lithologic Description	Well: PZ-12 TOC Elev.: 296.59
					▼ 1 Hour = dry ▽ 24 Hours = dry	SS = Split Spoon ST = Shelby Tube RC = Rock Core BAG = Bag Sample		
0	293.48	13	SS, BAG	10			moist; medium compact; brownish yellow (10YR 6/6) with white specks; clayey silty quartz sandy gravel; no plasticity or cohesion; Soil Horizon; (Lab Results: PZ-13 Bag (0-1.5'); USCS=SC-SM; Gravel=36.1%; Sand=37.2%; Silt=19.4%; Clay=7.3%; Effective Porosity=25%; Atterberg Limits: PL=17, LL=21, PI=4)	
5	288.48	12	SS	21			moist; stiff; red (2.5YR 4/6); fine to medium sandy silt and silty clay layers; low plasticity; cohesive; Residuum	
10	283.48	50/5"	SS	6			moist; very hard; red (2.5YR 4/6); silty clay with large quartz gravel; no plasticity; cohesive; Residuum	
15	278.48	50/6"	SS	24			moist; very hard; weak red (10R 5/3) with light green mottles; medium horizontal fissle; silty clay; no plasticity; cohesive; Residuum	
20	273.48	11/22	SS	20			moist; hard; pinkish gray (7.5YR 6/2) with black vertical and 45 degree planes; medium horizontal fissle; silty clay; no plasticity; cohesive; Residuum	
25	268.48	50/6"	SS	18			moist; very hard; gray (7.5YR 5/1); medium horizontal fissle; silty clay; no plasticity; cohesive; Partially Weathered Rock	
30	263.48	11/50/5"	SS	22			moist; very hard; gray (7.5YR 5/1); medium horizontal fissle; silty clay; no plasticity; cohesive; Residuum	
35	258.48	50/1"	SS	3			dry; very hard; dark blueish gray (Gley 2 4/1); weathered mudstone; Partially Weathered Rock	
40	253.48						Auger Refusal @ 35'	

SC-SM

ML

CL

PWR



Buxton Environmental, Inc.
 Consulting Services
 1101 South Blvd., Suite 101
 Charlotte, North Carolina 28203
 Ph (704) 344-1450 Fax (704) 344-1451
 buxtonenv@bellsouth.net

Boring Log, PZ-14

(Page 1 of 1)

Sanford Mine Reclamation Site
 1303 Brickyard Road
 Sanford, North Carolina

Date Started: 7/23/14
 Date Completed: 7/23/14
 Drilling Company: Summit Engineering
 Drillers Name: Robert Cassell
 NC Driller Certification: 4143A

Logged By: Ross Klingman, P.G.
 Drilling Method: HSA; CME-550x
 Top-of-Casing Elev.: 322.15'(Lawrence Survey)
 Ground Surface Elev.: 319.44'(Lawrence Survey)
 Natural, Cut, Fill Grade: natural

Depth (feet bgs.)	Elevation (feet asl.)	Blow Count/6-inches	Sampler Type	Recovery (in.)	Water Levels ▼ 1 Hour = dry ▽ 24 Hours = dry	Sample Type SS = Split Spoon ST = Shelby Tube RC = Rock Core BAG = Bag Sample	Lithologic Description	Well: PZ-14 TOC Elev.: 322.15
0	319.44	13	SS	16			moist; stiff; reddish yellow (7.5YR 6/8) with rust and light gray mottles; gravelly silty clay; low plasticity; cohesive; Soil Horizon <i>CL</i>	
5	314.44	11	SS	18			moist; stiff; reddish yellow (7.5YR 6/8) with rust and light gray mottles; gravelly silty clay; low plasticity; cohesive; Soil Horizon <i>CL</i>	
			ST	12			moist; reddish yellow (7.5YR 6/8) with rust and light gray mottles; large quartz gravelly silty clay; low plasticity; cohesive; Soil Horizon; (Lab Results: PZ-14 UD (6-7'); USCS=CH; Gravel=1.8% Sand=18.4%; Silt=37.7; Clay=42.1%; Specific Gravity=2.67; Hydraulic Conductivity=1.35 x 10 ⁻⁷ cm/sec; Total Porosity=38.6%; Effective Porosity=2%; Atterburg Limits: PI=28, LL=55, PL=27) <i>CH</i>	
10	309.44	14	SS	15			moist; stiff; red (10R 4/6) with white specks; clayey quartz gravelly fine to coarse sandy silt; no plasticity, cohesive; Residuum <i>ML</i>	
15	304.44	18	SS	18			moist; very stiff; red (10R 4/6) with white specks; clayey quartz gravelly fine to coarse sandy silt; no plasticity, cohesive; Residuum <i>ML</i>	
20	299.44	18	SS	20			moist; very stiff; red (10R 4/8); silty clay; low plasticity; cohesive; Residuum <i>CL</i>	
25	294.44	21	SS	18			moist; very hard; weak red (10R 5/3) with white and gray specks; fine to medium sandy silty clay; low plasticity; cohesive; Residuum <i>CL</i>	
30	289.44	50/5"	SS	10			dry; very hard; red (10R 4/6); medium horizontal fissle; clayey fine to medium sandy silt; no plasticity; cohesive; Partially Weathered Rock <i>PWR</i>	
35	284.44	50/1"	SS	8			moist; very hard; weak red (10R 4/6); highly horizontal fissle; weathered mudstone; Partially Weathered Rock	
40	279.44	50/0"	SS	1			moist; very hard; weak red (10R 4/3); highly horizontal fissle; weathered mudstone; Partially Weathered Rock	
45							Auger Refusal @ 39'	

CL
CH
ML
CL

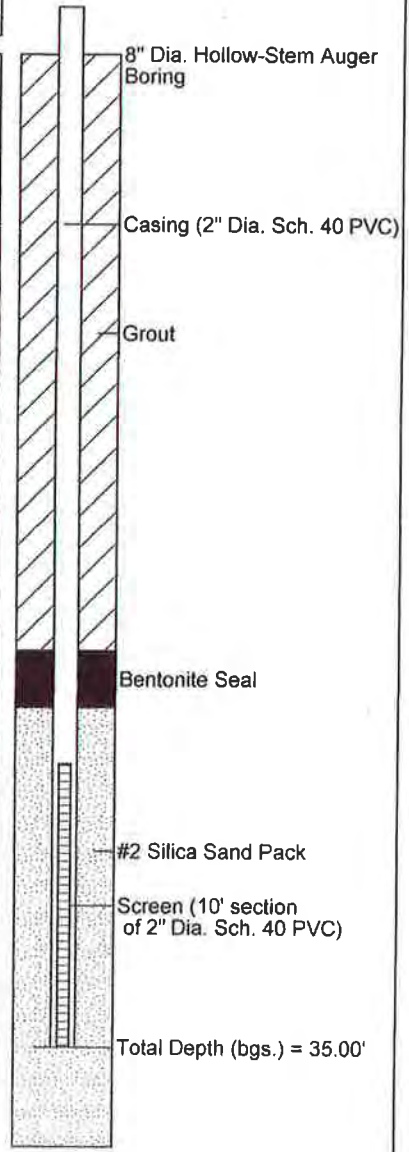



Buxton Environmental, Inc.
 Consulting Services
 1101 South Blvd., Suite 101
 Charlotte, North Carolina 28203
 Ph (704) 344-1450 Fax (704) 344-1451
 buxtonenv@bellsouth.net

Boring Log, PZ-15s and 15

Sanford Mine Reclamation Site
 1303 Brickyard Road
 Sanford, North Carolina

Date Started: 7/23/14
 Date Completed: 7/23/14
 Drilling Company: Summit Engineering
 Drillers Name: Robert Cassell
 NC Driller Certification: 4143A

Logged By: Ross Klingman, P.G.
 Drilling Method: HSA; CME-550x
 Top-of-Casing Elev.: 303.11/303.24'
 Ground Surface Elev.: 300.63'
 Natural, Cut, Fill Grade: natural

Depth (feet bgs.)	Elevation (feet asl.)	Blow Count/6-inches	Sampler Type	Recovery (in.)	Water Levels	Sample Type	Lithologic Description
					▼ 1 Hour = 13.48/15.34' bgs ▽ 24 Hours = 13.65/13.31' bgs	SS = Split Spoon ST = Shelby Tube RC = Rock Core BAG = Bag Sample	
0	300.63	12	SS	18			moist; medium; yellowish red (7.5YR 6/6); coarse quartz sandy silty clay; medium plasticity; cohesive; Soil Horizon CL
5	295.63	11	SS	20			moist; very stiff; yellow (10YR 7/6) with rust and orange mottles; coarse quartz sandy silty clay; low plasticity; cohesive; Soil Horizon CL
10	290.63	13	SS	21			moist; very stiff; red (2.5YR 4/6) with light gray and yellow mottles; silty clay; medium plasticity; cohesive; Residuum CL
15	285.63	28	SS	18			moist; hard; red (10R 4/6) with white specks; blocky; silty clay; low plasticity; cohesive; Residuum CL
20	280.63	50/4"	SS	18			moist; very hard; red (2.5YR 4/6) with white specks; blocky; silty clay; low plasticity; cohesive; Residuum CL
25	275.63	50/6"	SS, BAG	16			wet; very hard; red (10R 4/6) with white specks; medium horizontal fissile; silty clay; low plasticity; cohesive; Partially Weathered Rock; (Lab Results: PZ-15 Bag (23.5-24'): USCS=CL; Gravel=0.7%; Sand=4.5%; Silt=52.8%; Clay=19.9%; Effective Porosity=8; Atterberg Limits: PI=16, LL=32, PI=16)
30	270.63	50/5"	SS	18			wet; very hard; weak red (10R 5/4) with light gray specks; highly horizontal fissile; weathered mudstone; Partially Weathered Rock

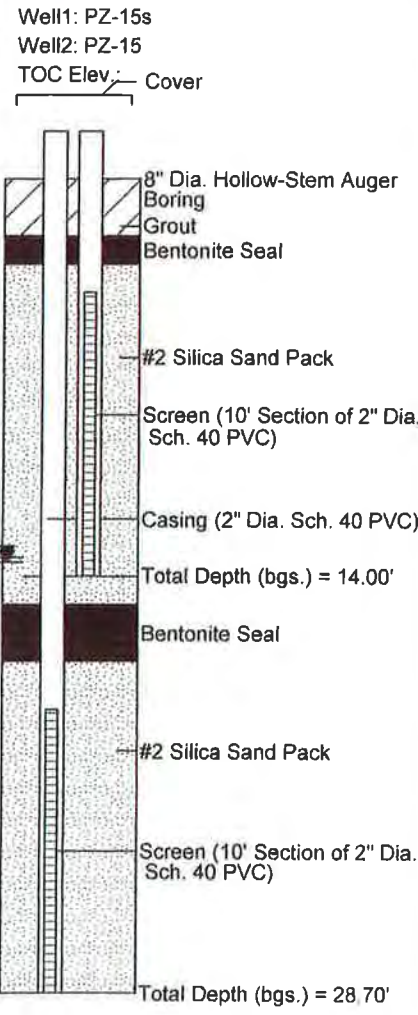

CL

PWR

SH

45

50/4"

50/6"

50/5"



Buxton Environmental, Inc.
 Consulting Services
 1101 South Blvd., Suite 101
 Charlotte, North Carolina 28203
 Ph (704) 344-1450 Fax (704) 344-1451
 buxtonenv@bellsouth.net

Boring Log, PZ-16

(Page 1 of 1)

Sanford Mine Reclamation Site
 1303 Brickyard Road
 Sanford, North Carolina

Date Started: : 7/23/14
 Date Completed: : 7/23/14
 Drilling Company: : Summit Engineering
 Drillers Name: : Robert Cassell
 NC Driller Certification: : 4143A

Logged By: : Ross Klingman, P.G.
 Drilling Method: : HSA; CME-550x
 Top-of-Casing Elev.: : 272.78'(Lawrence Survey)
 Ground Surface Elev.: : 270.63'(Lawrence Survey)
 Natural, Cut, Fill Grade: : natural (drainage bottom)

Depth (feet bgs.)	Elevation (feet asl.)	Blow Count/6-inches	Sampler Type	Recovery (in.)	Water Levels	Sample Type	Lithologic Description
					▼ 1 Hour = 22.35' bgs ▽ 24 Hours = 8.33' bgs	SS = Split Spoon ST = Shelby Tube RC = Rock Core BAG = Bag Sample	
0	270.63	11	SS	24			moist; stiff; strong brown (7.5YR 5/6) with white specks; quartz gravelly clayey silt; no plasticity; cohesive; Soil Horizon <i>MH</i>
5	265.63	10	SS	16			moist; stiff; yellowish red (5YR 4/6) with light gray mottles; silty clay; low plasticity; cohesive; Soil Horizon <i>CL</i>
10	260.63	32 38	SS	14			dry; very hard; dark red (10R 3/6); horizontal fissile; weathered mudstone; Residuum
15	255.63	17 31	SS	16			moist; very hard; red (10R 4/6) with purple mottles; mica sandy silty clay; no plasticity; cohesive; Residuum <i>CL</i>
20	250.63	58 1/2"	SS, BAG	10			moist; very hard; red (10R 4/6) with purple mottles; silty clay; no plasticity; cohesive; Partially Weathered Rock; (Lab Results: PZ-16 Bag (18.5-20'): USCS=CL; Sand=3.1%; Silt=65.5%; Clay=31.4%; Effective Porosity=3; Atterberg Limits: PI=19, LL=38, PI=19)
25	245.63	50/3"	SS	6			wet; very hard; red (10R 4/6) with purple mottles; highly horizontal fissile; silty clay; no plasticity; cohesive; Partially Weathered Rock
30	240.63						
35	235.63						
40	230.63						
45							

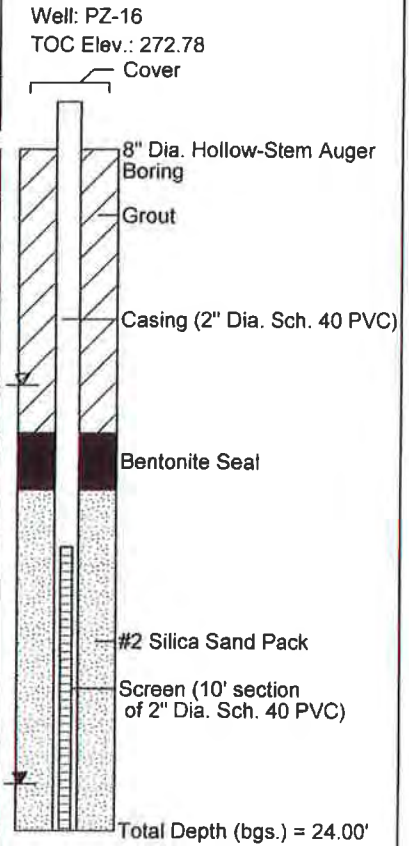

MH
SH
CL
CL
PWR



Buxton Environmental, Inc.
 Consulting Services
 1101 South Blvd., Suite 101
 Charlotte, North Carolina 28203
 Ph (704) 344-1450 Fax (704) 344-1451
 buxtonenv@bellsouth.net

Boring Log, PZ-17s and 17

(Page 1 of 1)

Sanford Mine Reclamation Site
 1303 Brickyard Road
 Sanford, North Carolina

Date Started: 7/23/14
 Date Completed: 7/23/14
 Drilling Company: Summit Engineering
 Drillers Name: Robert Cassell
 NC Driller Certification: 4143A

Logged By: Ross Klingman, P.G.
 Drilling Method: HSA; CME-550x
 Top-of-Casing Elev.: 306.62/306.56'
 Ground Surface Elev.: 304.00'
 Natural, Cut, Fill Grade: natural

Depth (feet bgs.)	Elevation (feet asl.)	Blow Count/6-inches	Sampler Type	Recovery (in.)	Water Levels	Sample Type
					▼ 1 Hour = dry/27.44" ▽ 24 Hours = dry/27.46" bgs	SS = Split Spoon ST = Shelby Tube RC = Rock Core BAG = Bag Sample
Lithologic Description						

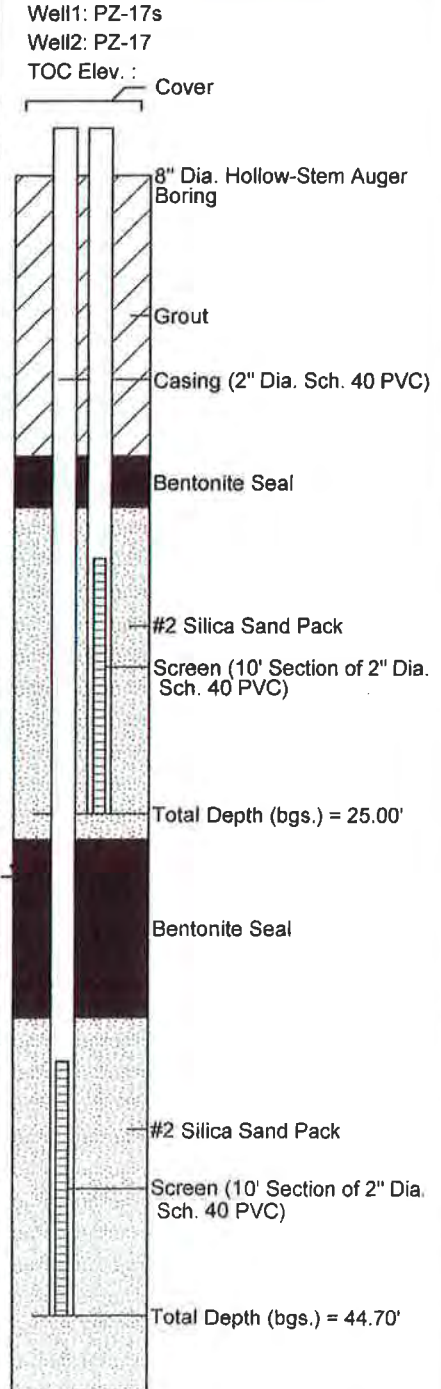

CL

PWR

PBR

0	304	7	SS	24	moist; stiff; reddish brown (5YR 4/4); silty clay; medium plasticity; cohesive; Residuum	CL
5	299	12	SS	16	moist; stiff; reddish brown (5YR 4/4); silty clay with mudstone rock fragments; medium plasticity; cohesive; Residuum	CL
10	294	50/4"	SS	14	dry; very hard; reddish brown (2.5YR 5/4); highly horizontal fissile; weathered mudstone; Partially Weathered Rock	
15	289	50/6"	SS	8	dry; very hard; reddish brown (2.5YR 5/4); highly horizontal fissile; weathered mudstone; Partially Weathered Rock	
20	284	50/2"	SS	12	dry; very hard; reddish brown (2.5YR 5/4); highly horizontal fissile; weathered mudstone; Partially Weathered Rock	
25	279	18/26"	SS	18	dry; very hard; weak red (2.5YR 4/2); medium horizontal fissile; weathered mudstone; Residuum	
30	274	50/3"	SS	12	dry; very hard; weak red (2.5YR 4/2); medium horizontal fissile; weathered mica sandy mudstone; Partially Weathered Rock	
35	269	50/3"	SS	8	dry; very hard; weak red (2.5YR 4/2); medium horizontal fissile; weathered mica sandy mudstone; Partially Weathered Rock	
40	264	50/4"	SS	8	very moist; very hard; weak red (2.5YR 4/2); blocky; fine sandy clayey silt; no plasticity; cohesive; Partially Weathered Rock	
45	259	38/50/3"	SS,BAG	14	wet; very hard; reddish brown (2.5YR 4/4); medium horizontal fissile; weathered mudstone; Partially Weathered Rock; (Lab Results: PZ-17 Bag (43.5-44.5'); USCS=CL; Sand=40.2%; Silt=48.9%; Clay=10.9%; Effective Porosity=16%; Atterberg Limits: PL=19, LL=32, PI=13)	



Buxton Environmental, Inc.
 Consulting Services
 1101 South Blvd., Suite 101
 Charlotte, North Carolina 28203
 Ph (704) 344-1450 Fax (704) 344-1451
 buxtonenv@bellsouth.net

Boring Log, PZ-18

(Page 1 of 1)

Sanford Mine Reclamation Site
 1303 Brickyard Road
 Sanford, North Carolina

Date Started: 7/23/14
 Date Completed: 7/23/14
 Drilling Company: Summit Engineering
 Drillers Name: Robert Cassell
 NC Driller Certification: 4143A

Logged By: Ross Klingman, P.G.
 Drilling Method: HSA; CME-550x
 Top-of-Casing Elev.: 294.72'(Lawrence Survey)
 Ground Surface Elev.: 292.27'(Lawrence Survey)
 Natural, Cut, Fill Grade: natural

Depth (feet bgs.)	Elevation (feet asl.)	Blow Count/6-inches	Sampler Type	Recovery (in.)	Water Levels	Sample Type	Lithologic Description
					▼ 1 Hour = dry ▽ 24 Hours = dry	SS = Split Spoon ST = Shelby Tube RC = Rock Core BAG = Bag Sample	
0	292.27	1	SS	22			moist; medium, brownish yellow (10R 6/6); slightly clayey silt; no plasticity; cohesive; Soil Horizon <i>mit</i>
5	287.27	4	SS	16			moist; stiff, reddish yellow (7.5YR 6/8) with tan and rust mottles; silty clay; medium plasticity; cohesive; Soil Horizon <i>CL</i>
10	282.27	5	SS	15			moist; very stiff, red (10R 4/8) with light green gray mottles; silty clay; low plasticity; cohesive; Residuum <i>CL</i>
15	277.27	21	SS	18			moist; hard, red (10R 4/8) with light green gray mottles; highly horizontal fissile; very fine sandy clayey silt; no plasticity; cohesive; Residuum <i>mit</i>
20	272.27	40	SS,BAG	12			moist; very hard; red (10R 4/8) with light green gray mottles; highly horizontal fissile; very fine sandy clayey silt; no plasticity; cohesive; Partially Weathered Rock; (Lab Results: PZ-18 Bag (18.5-19.5'); USCS=CL; Sand=24.4%; Silt=55.7%; Clay=19.9%; Effective Porosity=8%; Atterberg Limits: PL=17, LL=32, PI=15)
25	267.27	9	SS	10			moist; very hard; red (10R 4/8) with black horizontal planes; blocky and medium horizontal fissile; silty clay; no plasticity; cohesive; Partially Weathered Rock
30	262.27	50/6"	SS	8			moist; very hard; red (10R 4/8); highly horizontal fissile; weathered mudstone; Partially Weathered Rock
35	257.27	50/3"	SS	8			dry; very hard; weak red (10R 4/3); highly horizontal fissile; fine mica sandy silt; no plasticity; cohesive; Partially Weathered Rock
40	252.27	50/3"	SS	5			moist; very hard; red (10R 4/8); highly horizontal fissile; weathered mudstone; Partially Weathered Rock
45		50/3"	SS	4			moist; very hard; red (10R 4/8) with purple mottles; blocky; weathered mudstone; Partially Weathered Rock

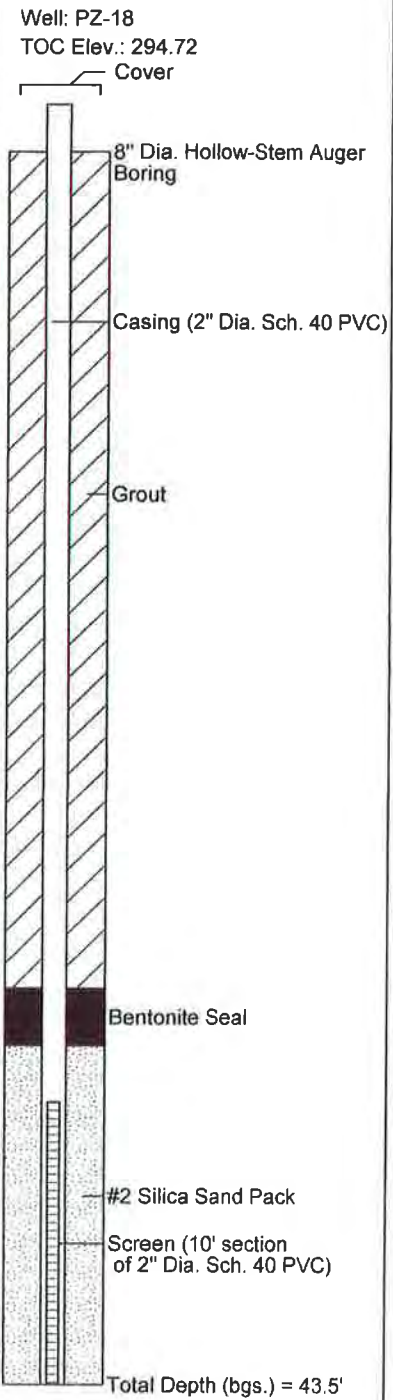

mit
CL
mit
mit

SH

6
4
5
7
5
12
19
21
24
45
40
50/3"
9
50/3"
50/6"
50/3"
50/3"
50/3"

BL

mit

CL

CL

mit

Total Depth (bgs.) = 43.5'



Buxton Environmental, Inc.
 Consulting Services
 1101 South Blvd., Suite 101
 Charlotte, North Carolina 28203
 Ph (704) 344-1450 Fax (704) 344-1451
 buxtonenv@bellsouth.net

Boring Log, PZ-19

(Page 1 of 1)

Sanford Mine Reclamation Site
 1303 Brickyard Road
 Sanford, North Carolina

Date Started: 8/29/14
 Date Completed: 8/29/14
 Drilling Company: Environmental Drilling & Probing
 Drillers Name: Tommy Bolyard
 NC Driller Certification: 3307

Logged By: Ross Klingman, P.G.
 Drilling Method: HSA; Geoprobe 7822
 Top-of-Casing Elev: (Lawrence Survey)
 Ground Surface Elev: 265.99'(Lawrence Survey)
 Natural, Cut, Fill Grade: slight cut

Depth (feet bgs.)	Elevation (feet asl.)	Blow Count/6-inches	Sampler Type	Recovery (in.)	Water Levels ▼ 1 Hour = 11.00' bgs ▽ 24 Hours = 5.75' bgs	Sample Type SS = Split Spoon ST = Shelby Tube RC = Rock Core BAG = Bag Sample	Lithologic Description	Well: PZ-19 TOC Elev.: Cover 6" Dia. Hollow-Stem Auger Boring Grout Casing (2" Dia. Sch. 40 PVC) Bentonite Seal #2 Silica Sand Pack Screen (10' section of 2" Dia. Sch. 40 PVC) Total Depth (bgs.) = 24.70
0	265.99	5	SS	24			wet; medium; light brownish gray (10YR 6/2) with light orange mottles; silty clay; medium plasticity; cohesive; Soil Horizon <i>CL</i>	
5	260.99	3	SS	18			wet; soft; light brownish gray (10YR 6/2) with light orange mottles; silty clay; medium plasticity; cohesive; Soil Horizon <i>CL</i>	
10	255.99	15 20 27	SS	17			moist; hard; yellowish brown (10YR 5/4); medium horizontal fissile; clayey silt; no plasticity; cohesive; Residuum <i>mlt</i>	
15	250.99	6 18 50/4"	SS	24			moist; very hard; yellowish brown (10YR 5/4) with black manganese planes; medium horizontal fissile; clayey silt; no plasticity; cohesive; Residuum <i>hlt</i>	
20	245.99	24 50/3"	SS	10			dry; very hard; brown (10YR 5/3); highly horizontal fissile; weathered mudstone; Partially Weathered Rock	
25	240.99	14 50/3"	SS	12			wet; very hard; reddish brown (5YR 4/3); medium horizontal fissile; weathered mudstone; Partially Weathered Rock	
30	235.99							
35	230.99							
40	225.99							
45								

CL

mlt

pwr

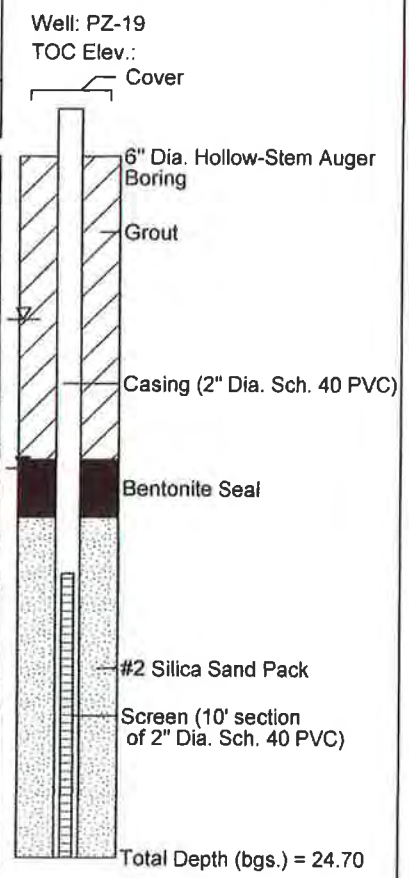



Buxton Environmental, Inc.
 Consulting Services
 1101 South Blvd., Suite 101
 Charlotte, North Carolina 28203
 Ph (704) 344-1450 Fax (704) 344-1451
 buxtonenv@bellsouth.net

Boring Log, PZ-20

(Page 1 of 1)

Sanford Mine Reclamation Site
 1303 Brickyard Road
 Sanford, North Carolina

Date Started: : 8/29/14
 Date Completed: : 8/29/14
 Drilling Company: : Environmental Drilling & Probing
 Drillers Name: : Tommy Bolyard
 NC Driller Certification: : 3307

Logged By: : Ross Klingman, P.G.
 Drilling Method: : HSA; Geoprobe 7822
 Top-of-Casing Elev.: : (Lawrence Survey)
 Ground Surface Elev.: : 296.51' (Lawrence Survey)
 Natural, Cut, Fill Grade: : natural

Depth (feet bgs.)	Elevation (feet asl.)	Blow Count/6-inches	Sampler Type	Recovery (in.)	Water Levels	Sample Type	Lithologic Description
					▼ 1 Hour = 24 00' bgs ▽ 24 Hours = 12 44' bgs	SS = Split Spoon ST = Shelby Tube RC = Rock Core BAG = Bag Sample	
0	296.51	6	SS	24			moist; medium; Red (2.5YR 4/6) with yellow mottles; fine sandy silty clay; low plasticity; cohesive; Soil Horizon <i>CL</i>
5	291.51	9	SS	24			moist; stiff; red (2.5YR 4/6) with yellow mottles; fine sandy silty clay; low plasticity; cohesive; Soil Horizon <i>CL</i>
10	286.51	11	SS	20			moist; stiff; red (2.5YR 4/6) with yellow mottles; mica sandy silty clay; low plasticity; cohesive; Soil Horizon <i>CL</i>
15	281.51	12	SS	18			very moist; stiff; weak red (10R 4/4) with white and light gray specks; phyllite and quartz gravelly sandy silty clay; no plasticity; cohesive; Residuum <i>CL</i>
20	276.51	50/3"	SS	8			dry; very hard; weak red (10R 4/4) with white and light gray specks; weathered mudstone; Partially Weathered Rock <i>PWR</i>
25	271.51	50/4"	SS	8			wet; very hard; red (10R 4/6); highly horizontal fissle; mica sandy clayey silt; no plasticity; cohesive; Partially Weathered Rock

Well: PZ-20
 TOC Elev.:
 Cover

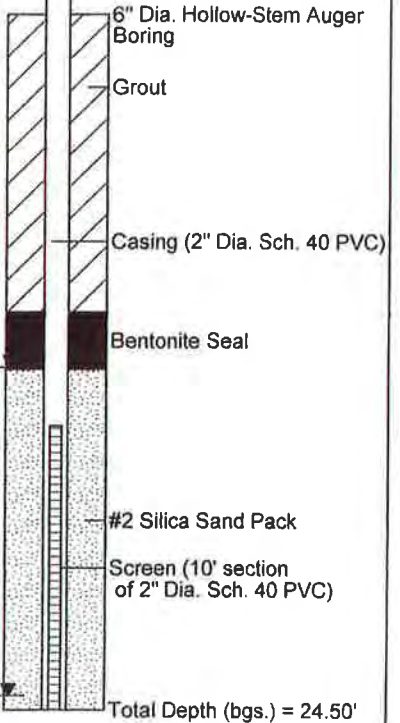



3620 Pelham Road, PMB #292 Phone: 864-329-0013
Greenville, SC 29615-5044 FAX: 864-329-0014

June 30, 2014

Charah, Inc
12601 Plantside Drive
Louisville, KY 40299

Attention: Mr. Norman E. Divers, III

Re: Physical Characterization Testing of Coal Combustion By-products
Riverbend Steam Station
Mount Holly, NC
GeoTrack Project No. 14-3425-N

Ladies and Gentlemen:

GeoTrack Technologies, Inc. has completed characterization testing of a sample from the referenced plant, and we present the results herein. The work was performed as a preliminary evaluation of whether the material is satisfactory for use as structural fill at the Charlotte-Douglas Airport, Area C. This letter presents a brief summary of the procedures and presents the testing results.

Project Description: The material in question includes coal combustion by-products that might include a mixture of fly ash and bottom ash that are collected and discharged to holding ponds on the power plant property. The combined combustion by-products (hereinafter referred to as CCB's) are proposed for use in an engineered fill. The engineered fill will be constructed by excavating native soils, constructing a composite (membrane) liner, placing the CCB as compacted fill, and covering the fill with a combination of a membrane cap and compacted soil. Subsequent uses of the completed fill have not been finalized; we anticipate that the property could be developed as part of nearby airport expansion, for commercial purposes (retail development, light industrial, etc), or to reclaim land that was previously excavated for other purposes.

Sampling Procedures: GeoTrack visited the power plant on May 15, 2014 and collected CCB samples. Grab samples were collected from the pond nearest the plant site (a wet pond). The sample locations included the northern corner, at the primary effluent structure, and the diagonally opposite corner, near the primary influent. Those locations were selected because they provided access to the CCB. Most areas of the exposed CCB were saturated and soft to both vehicular and pedestrian traffic.

Sampling was performed using procedures in general conformance with ASTM C 311 (ASTM D 75) for physical testing. The physical test sample was split in accordance with ASTM procedures

and subjected to various laboratory tests. The physical (engineering) tests included classification tests, strength tests, and consolidation tests.

Portions of the samples were also placed in laboratory-prepared containers in accordance with applicable EPA SW846 procedures for the chemical analyses. The chemical analyses are reported separately.

Physical (Engineering) Testing: Table 1 presents the physical (engineering) tests performed, the applicable test methods, and the results. Where applicable, individual test reports are attached. Detailed evaluation of the engineering characteristics is beyond the scope of this report, and the suitability of the various properties is dependent upon final site geometry and fill usage; however, a few comments are offered based upon our preliminary review of the test results.

The grain size characteristics and specific gravity are within expected ranges based on general experience with similar CCB's. The material consists predominantly of silt-sized particles that are essentially cohesionless in nature. Atterberg limits tests indicate the material to be non-plastic despite the fine grained size characteristics. The sand content of the sample might be influenced by the bottom ash content of this CCB.

The Standard Proctor Maximum Dry Density achieved for this sample (56.6 pounds per cubic foot (pcf) at an optimum moisture content of 48 percent) was low relative to the range typically achieved for similar products. The Proctor curve is relatively flat, indicating the material is not sensitive to moisture content. The compaction curve indicates that 95 percent compaction can be theoretically achieved with the standard Proctor compactive effort over a range of moisture contents spanning greater than 10 percent. Our experience indicates considerable variability in densities, moisture contents, etc. might be expected, and these properties are most likely influenced by long-term variations in plant procedures and the flow/sedimentation processes within the pond.

Three separate specimens were collected from the bulk sample and tested for field moisture content. They were selected based on their proximity to the prevailing water level within the pond at the time of sampling (collected from above and below the water surface). They ranged from 50.0 to 92.2 percent by dry weight. The average of the three moisture contents was 73.3 percent. While this average moisture content is well above the optimum moisture content, the wide variation in collected samples indicates that significant reductions in moisture content can occur simply by passively draining the materials. Also, more active moisture adjustment should require minor effort within temporary stockpiles and in the fill lifts.

Despite the low compacted dry density, the strength properties of this sample are favorable for most routine engineering applications. Three sets of strength properties were derived from two separate strength tests. The tests simulate both drained (effective or long-term) and undrained (total or short-term loading) conditions that might be experienced in service. The undrained strength test results indicate short-term strengths that varied, but are characteristic of fine grained materials. The undrained strength tests exhibited strength envelopes that are combinations of cohesion and internal friction. They exhibited undrained cohesion ranging from moderate to high ($C = 1,900$ to $4,300$ pounds per square foot; psf), with corresponding angles of internal friction

ranging from low to moderate ($\phi = 8$ to 27°). In combination, the two sets of computed undrained strength parameters represent moderately high overall strength characteristics.

The effective (drained) strength properties reported by the laboratory ($C = 2,600$ psf and $\phi = 22^\circ$) based on a "best-fit" strength envelope were uncharacteristic of cohesionless materials. That result is assessed to be the result of scatter in the laboratory results, which is common with earthen materials. Often CCB materials and similar fine-grained, non-plastic materials exhibit low to non-existent cohesion, and the strength is derived almost entirely from internal friction. The reported drained parameters are more characteristic of undrained behavior; however, review of the graphical results indicates the drained test is subject to interpretation. A strength envelope drawn through the graphical origin ($C = 0$) and tangent to the lowest failure circle indicates a relatively high angle of internal friction ($\phi = 39^\circ$), with little deviation from the other failure circles. That adjusted strength envelope is both characteristic of non-plastic, cohesionless materials, and relatively high internal strength. The adjusted test results are similar to drained strengths of CCB materials sampled from other plants. The laboratory interpretation and adjusted strength parameters are shown in attachments.

Similarly, the consolidation test results indicate settlement characteristics of the CCB's will be favorable. With total strain of less than 3 percent and 4 percent at applied pressures of 8 and 16 kips per square foot (psf), respectively, the material has characteristics of low compressibility. Our experience indicates that the settlement characteristics will be comparable, or more favorable (less compressible) than, typical area soils.

Closing: GeoTrack is pleased to be of service to you on this project. Please call if you have any questions concerning this letter or if we may provide additional assistance.

Respectfully submitted,
GeoTrack Technologies, Inc.



David D. Wilson, P.E.
Senior Engineer
NC Registration No. 17088



**TABLE 1 – PHYSICAL/ENGINEERING CHARACTERISTICS
RIVERBEND STEAM STATION
GEOTRACK PROJECT NO. 14-3425-N**

Physical/Engineering Characteristic	Test Method	Test Result/ Applicable Parameters	Remarks
Grain Size Distribution	ASTM 422	22 Percent Sand 72 Percent Silt 6 Percent Clay <i>Grain Size Distribution Attached</i>	Sieve and Hydrometer
Specific Gravity	ASTM 854	Specific Gravity: $G_s = 2.13$	
Water Content	ASTM D 2216	Field Moisture Content: $w = 73.3\%$	Moisture Content at Time of Sampling – Note 5
Compaction	ASTM D 698	Maximum Dry Density: $\gamma_{d\max} = 56.6$ pcf Optimum Moisture Cont.: $w_{opt} = 48.0\%$ <i>Moisture Density Relationship Attached</i>	Standard Proctor Compaction Test
Strength:			
Shear Strength	ASTM 4767	Total Cohesion: $C = 4.3$ ksf Total Angle of Int. Friction: $= 8^\circ$ Eff. Cohesion: $C' = 2.6$ ksf Eff. Angle of Int. Friction: $\phi' = 22^\circ$ <i>Triaxial Shear Test Report Attached</i>	Consolidated Undrained Triaxial Shear Test with Pore Pressure Measurements Note 3 Note 4
Compressive Strength	ASTM 2850	Total Cohesion: $C = 1.9$ ksf Total Angle of Int. Friction: $\phi = 27^\circ$ <i>Triaxial Shear Test Report Attached</i>	Unconsolidated Undrained Triaxial Shear Test. Unconfined Compressive Strength not Meaningful for Ash Samples Note 3 Note 3
Compressibility	ASTM D 2435	<i>Consolidation Test Report Attached</i>	Note 3

See notes on next page

Notes: 1. Sample collected May 15, 2014

2. The referenced ASTM procedures are as suggested in ASTM E 2277, and common geotechnical practice.
3. Tests performed on specimens remolded in the laboratory to approx. 95% of the Standard Proctor Maximum Dry Density at approximately the Optimum Moisture Content.
4. An alternative strength envelope derived from the test data is shown graphically in the attachments.
5. The reported field moisture content is the average of three separate specimens with moisture contents ranging from 50.0 to 92.2 %.

Moisture - Density Report



Quality Assurance

S&ME, Inc. - Greenville 281 Fairforest Way Greenville, SC 29607

S&ME Project #:	1263-10-195	Report Date:	6/02/14
Project Name:	Geotrack Technologies, Inc. - 14-3425-N	Test Date:	5/30/14
Client Name:	3620 Pelham Road, PMB #292 Greenville, SC 29615		
Client Address:	336 Longview Drive Piedmont, South Carolina 29673		
Boring #:	N/A	Log #:	44g
Location:	Riverbend Pond	Type:	Bulk
Sample Description:	Coal Ash	Sample Date:	5/15/14
		Depth:	N/A

Maximum Dry Density 56.6 PCF. Optimum Moisture Content 48.0%

ASTM D 698 -- Method A

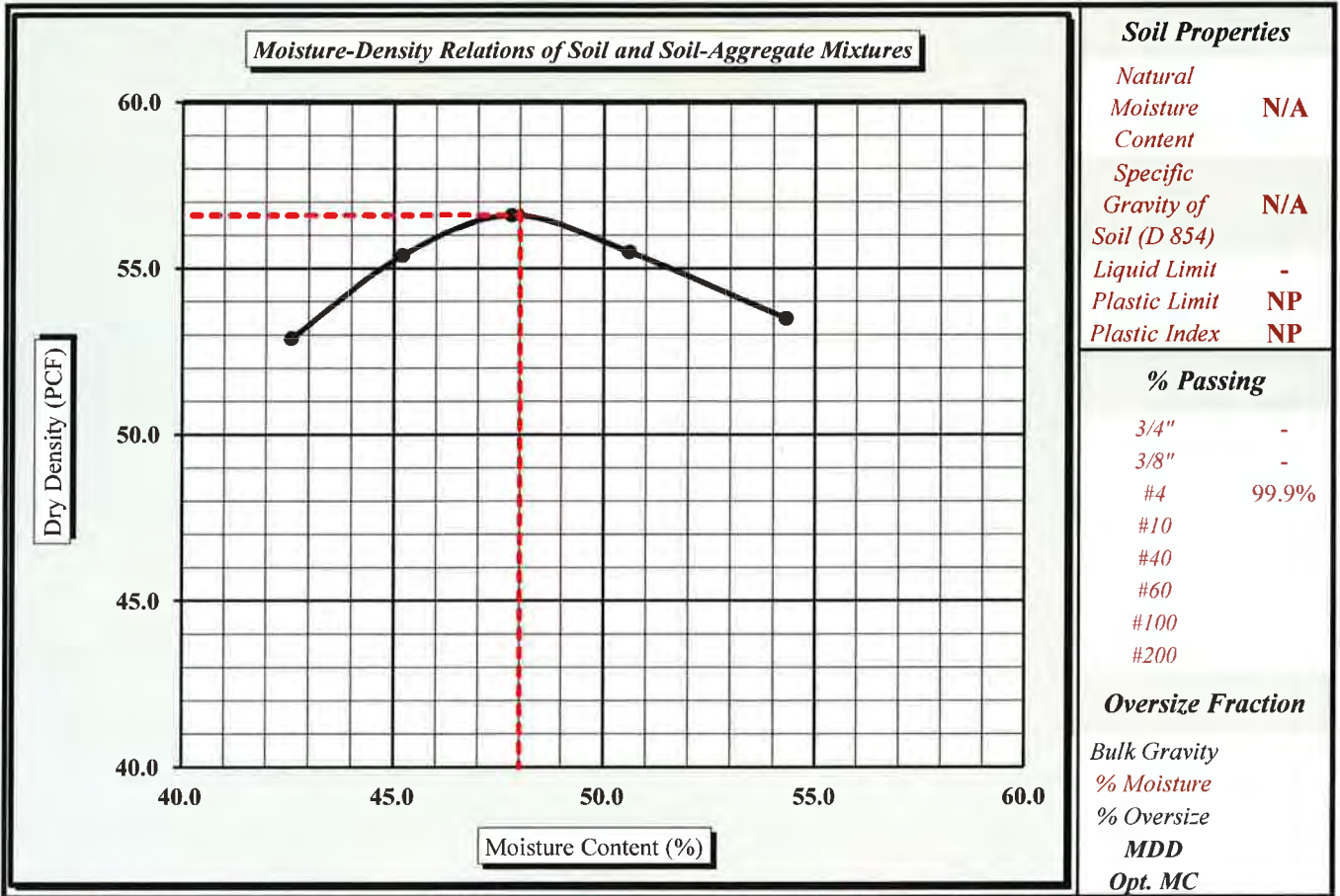

Moisture-Density Curve Displayed: Fine Fraction Corrected for Oversize Fraction (ASTM D 4718)
 Sieve Size used to separate the Oversize Fraction: #4 Sieve 3/8 inch Sieve 3/4 inch Sieve
 Mechanical Rammer Manual Rammer Moist Preparation Dry Preparation

References / Comments / Deviations:

- ASTM D 2216: Laboratory Determination of Water (Moisture) Content of Soil and Rock by Mass
- ASTM D 698: Laboratory Compaction Characteristics of Soil Using Standard Effort

Brian Vaughan, P.E.
 Technical Responsibility

Brian Vaughan
 Signature

Location Coordinator
 Position

6/02/14
 Date

This report shall not be reproduced, except in full, without the written approval of S&ME, Inc.

Particle Size Analysis of Soils



ASTM D 422

Quality Assurance

S&ME, Inc. - Greenville 281 Fairforest Way Greenville, SC 29607

S&ME Project #:	1263-10-195	Report Date:	6/05/14
Project Name:	Geotrack Technologies, Inc. - 14-3425-N	Test Date(s):	6/02 - 6/05/14
Client Name:	Geotrack Technologies, Inc.		
Address:	3620 Pelham Road, PMB #292 Greenville, SC 29615		
Boring #:	N/A	Log #:	44g
		Sample Date:	5/15/14
Location:	Riverbend Pond	Type:	Bulk
		Sample Depth:	N/A
Sample Description:	Coal Ash		

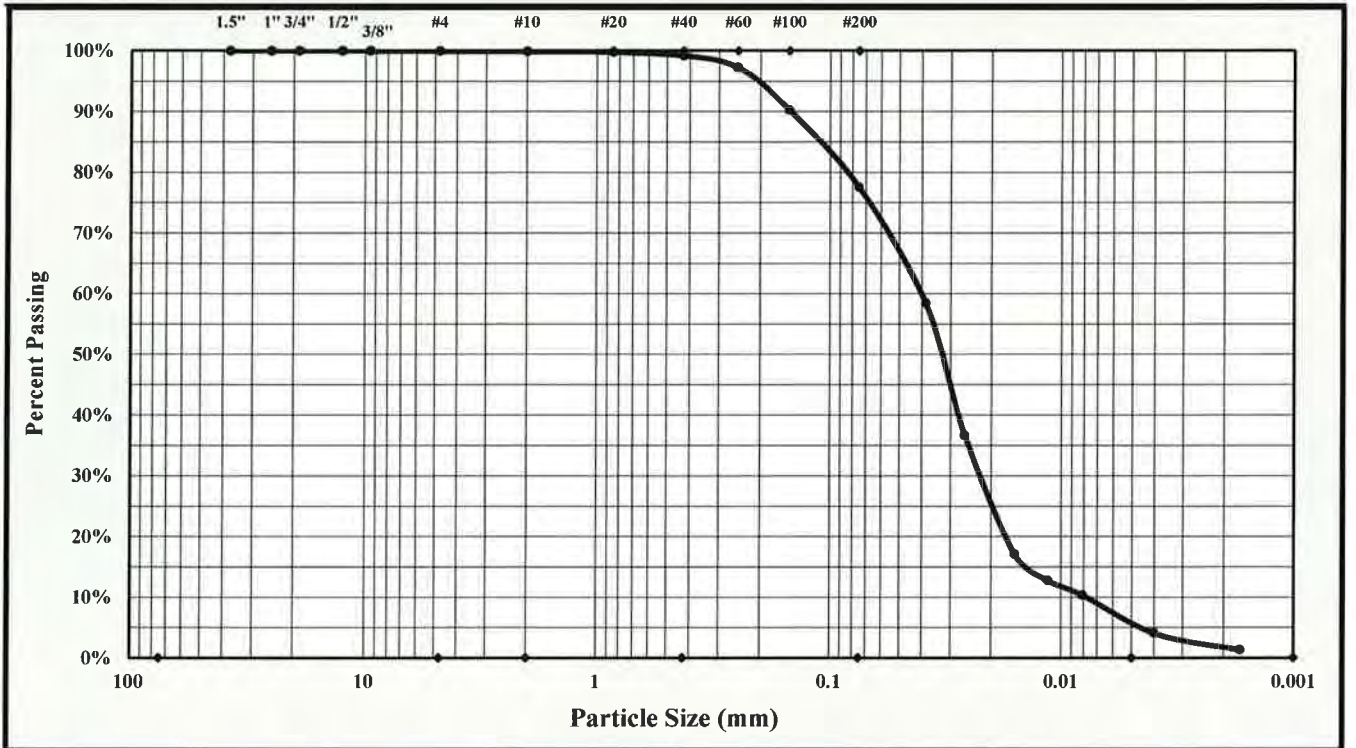

Cobbles	< 300 mm (12") and > 75 mm (3")	Fine Sand	< 0.425 mm and > 0.075 mm (#200)
Gravel	< 75 mm and > 4.75 mm (#4)	Silt	< 0.075 mm and > 0.005 mm
Coarse Sand	< 4.75 mm and > 2.00 mm (#10)	Clay	< 0.005 mm
Medium Sand	< 2.00 mm and > 0.425 mm (#40)	Colloids	< 0.001 mm

Maximum Particle Size:	.425 mm	Gravel:	0.1%	Silt	71.9%
Silt & Clay (% Passing #200):	77.5%	Total Sand:	22.4%	Clay	5.7%
Specific Gravity	2.130	Moisture Content		Colloids	1.0%
Liquid Limit	-	Plastic Limit	NP	Plastic Index	NP

Coarse Sand:	0.0%	Medium Sand:	0.7%	Fine Sand:	21.7%
--------------	------	--------------	------	------------	-------

Description of Sand and Gravel Rounded Angular Hard & Durable Soft Weathered & Friable

Mechanical Stirring Apparatus A Dispersion Period: 1 min. Dispersing Agent: Sodium Hexametaphosphate: 40 g./ Liter

References / Comments / Deviations: ASTM D 4318, D 854, D 2487

Brian Vaughan, P.E.
 Technical Responsibility

Brian Vaughan
 Signature

Location Coordinator
 Position

6/05/14
 Date

This report shall not be reproduced, except in full, without the written approval of S&ME, Inc.



CONSOLIDATION TEST REPORT



(ASTM D 2435)

Page 1

Project Name :		Geotrack Technologies, Inc. - 14-3425-N		Report Date:	6/13/2014
Project No. :		1263-10-195		Boring No.:	N/A
Client Name :		Geotrack Technologies, Inc.		Depth/Elev.:	N/A
Client Address :		3620 Pelham Road, PMB #292 Greenville, SC 29615		Sample Type:	Bulk
Initial Wet Density, γ_{wet} , pcf :	79.6	Load vs. Time Plot :	Log of time	Log No.:	44g
Initial Void Ratio, e_o :	1.472	Final Void Ratio, e_f :	1.400	Sp. Gravity, G_s :	2.13
Initial Saturation, S_o , % :	69.4	Final Saturation, S_f , % :	100.0	Estimated Preconsolidation	
Initial Dry Density, γ_{DRY} , pcf :	53.8	Final Dry Density, γ_{DRY} , pcf :	54.7	Stress, P_o , ksf :	1.0
Initial Moisture Content, % :	48.0	Final Moisture Content, % :	67.1	Fines, % :	77.5
Liquid Limit, % :	-	Plasticity Index, % :	NP		

Sample Description : Coal Ash

Remolded Properties : Specimen was remolded to 95% of maximum dry density at about 0% wet of optimum

Notes: Loading Schedule - as requested by client (ksf)- 0.25, 0.5, 1.0, 0.5, 0.25, 0.5, 1.0, 2.0, 4.0, 8.0, 16.0, 4.0, 1.0, 0.25

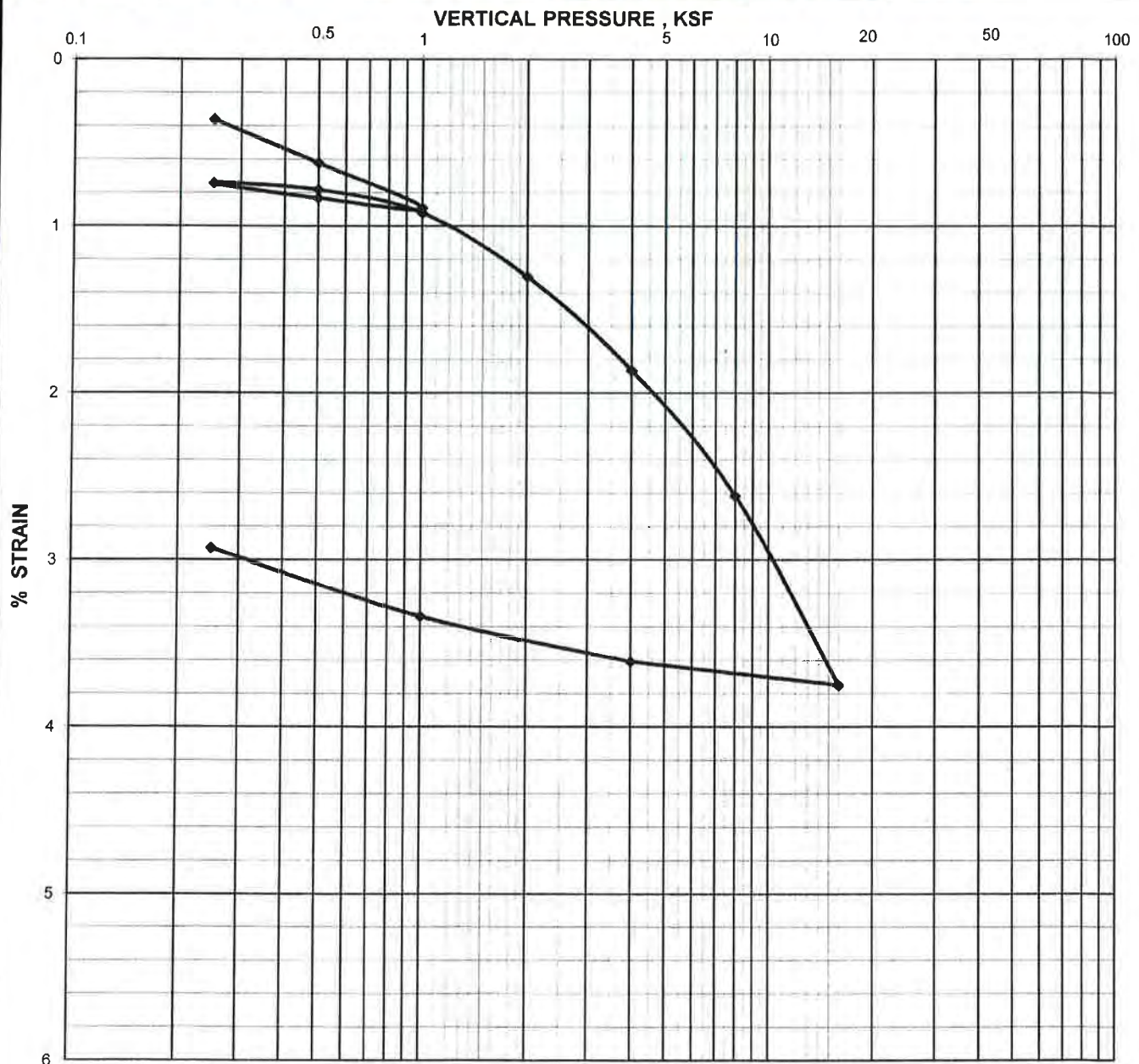



CONSOLIDATION TEST REPORT



(ASTM D 2436)

Page 2

Project Name :		Geotrack Technologies, Inc. - 14-3425-N	
Project No. :		1263-10-195	Report Date: 6/13/2014
Client Name :		Geotrack Technologies, Inc.	Boring No.: N/A
Client Address :		3620 Pelham Road, PMB #292 Greenville, SC 29615	Depth/Elev.: N/A
Initial Wet Density, γ_{wet} , pcf :	79.6	Load vs. Time Plot :	Log of time
Initial Void Ratio, e_o :	1.472	Final Void Ratio, e_f :	1.400
Initial Saturation, S_o , % :	69.4	Final Saturation, S_f , % :	100.0
Initial Dry Density, γ_{DRY} , pcf :	53.8	Final Dry Density, γ_{DRY} , pcf :	54.7
Initial Moisture Content, % :	48.0	Final Moisture Content, % :	67.1
Liquid Limit, % :	-	Plasticity Index, % :	NP
Sample Description :		Coal Ash	
Remolded Properties :		Specimen was remolded to 95% of maximum dry density at about 0% wet of optimum	
Notes: Loading Schedule - as requested by client (ksf)- 0.25, 0.5, 1.0, 0.5, 0.25, 0.5, 1.0, 2.0, 4.0, 8.0, 16.0, 4.0, 1.0, 0.25			





TRIAXIAL SHEAR TEST REPORT

(ASTM D 2850)
Unconsolidated Undrained



REV4,1/13/04

Project Name: Geotrack Technologies, Inc. - 14-3425-N
Project No.: 1263-10-195 **Report Date:** 06/10/14
Client Name: Geotrack Technologies, Inc. **Test Date:** 6/9/14
Client Address: 3620 Pelham Road, PMB #292 Greenville, SC 29615
Boring #: N/A **Depth / Elev. :** N/A **Log #:** 44g **Type:** Bulk
Sample Location : Riverbend Pond
Sample Description : Coal Ash

LL, % : - **PI, % :** NP **Percent Passing #200 :** 77.5 **G_s :** 2.130

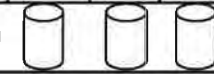
SPECIMEN PROPERTIES									TEST PARAMETERS, TEST TYPE : UU				
SPECIMEN NO.	INITIAL			FINAL			SPECIMEN NO.			1	2	3	
		1	2	3		1	2	3	B Value				
DIAMETER, INCHES	D _o	2.82	2.81	2.82	D _c	N/A	N/A	N/A	BACK PRESSURE, ksf	U _o	7.2	7.2	7.2
HEIGHT, INCHES	H _o	6.04	6.02	6.03	H _c	N/A	N/A	N/A	CONFINING PRESSURE, ksf	σ ₃	1.0	3.0	5.0
WATER CONTENT, %	W _o	48.0	48.0	48.0	W _c	N/A	N/A	N/A	MAX. DEVIATOR STRESS, ksf	σ ₁ -σ ₃	8.4	11.9	15.0
DRY DENSITY, PCF	γ _{dryo}	53.7	53.9	53.7	γ _{dryc}	N/A	N/A	N/A	ULT. DEVIATOR STRESS, ksf	σ ₁ -σ ₃	8.4	10.7	14.8
SATURATION, %	S _o	69.2	69.8	69.3	S _c	N/A	N/A	N/A	Specimen Shape @ Failure				
VOID RATIO	e _o	1.477	1.464	1.476	e _c	N/A	N/A	N/A	Sheared 				

CONTROLLED : Strain @ 1.0 % per minute

PROCTOR TYPE : Standard, **MAXIMUM DRY DENSITY, PCF :** 56.6, **OPTIMUM MOISTURE CONTENT, % :** 48.0

REMOVED : Specimens were remolded to 95 % of maximum dry density at about 0.0 % wet of o.m.c.

SHEAR STRENGTH PARAMETERS	TOTAL		EFFECTIVE	
	COHESION, C (ksf) :	1.9	APPARENT COHESION, (ksf) :	N/A
	ANGLE OF INTER. FRICTION, φ (DEGREES) :	27	ANGLE OF INTER. FRICTION, φ' (DEGREES) :	N/A

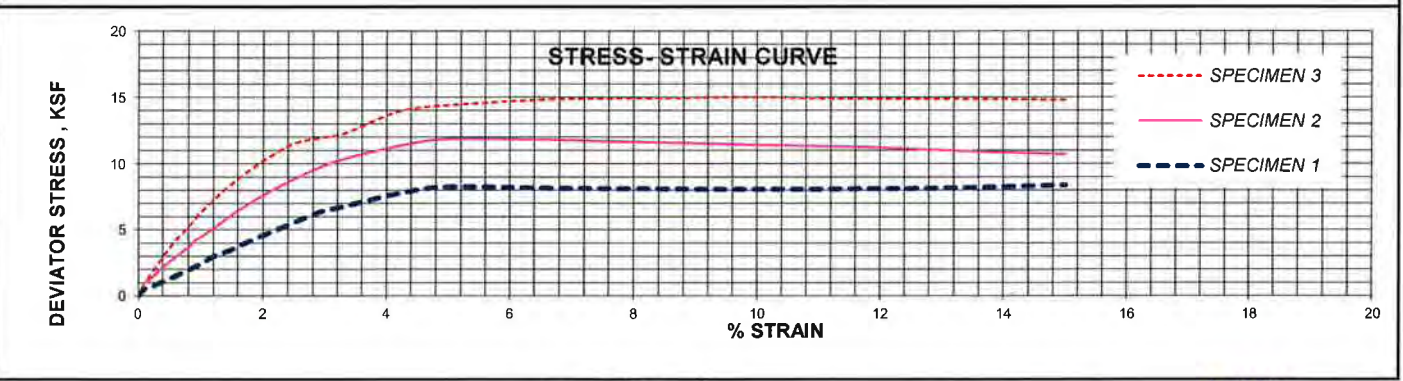
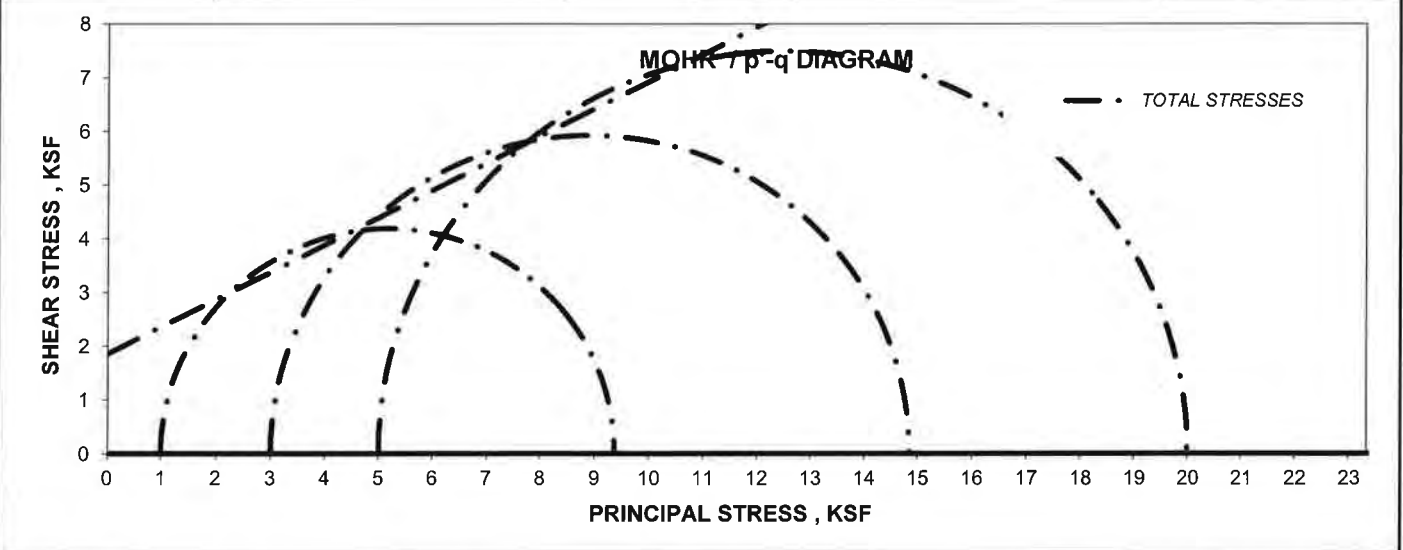

Brian Vaughan, P.E.
Technical Responsibility

Brian Vaughan
Signature

Location Coordinator
Position

06/10/14
Date



TRIAxIAL SHEAR TEST REPORT

(ASTM D 4767)



REV4, 1/13/04

Project Name: Geotrack Technologies, Inc. - 14-3425-N		Report Date: 06/10/14	
Project No.: 1263-10-195		Test Date: 6/02 - 6/10/14	
Client Name: Geotrack Technologies, Inc.		Client Address: 3620 Pelham Road, PMB #292 Greenville, SC 29615	
Boring No.: N/A	Depth / Elev.: N/A	Sample No.: 44g	Type: Bulk
Sample Location: Riverbend Pond			
Sample Description: Coal Ash			

LL, %: -	PI, %: NP	Percent Passing #200: 77.5	G_s: 2.130
-----------------	------------------	-----------------------------------	-----------------------------

SPECIMEN PROPERTIES									TEST PARAMETERS, TEST TYPE : CU/PP			
SPECIMEN NO.	INITIAL			AFTER CONSOLIDATION			SPECIMEN NO.	1	2	3		
	D_o	2.82	2.82	2.82	D_c	2.81					2.79	2.79
H_o	6.03	6.01	6.01	H_c	6.00	5.96	5.95	BACK PRESSURE, ksf	U_o	7.2	7.2	7.2
W_o	48.0	48.0	48.0	W_c	67.6	65.8	65.0	CONFINING PRESSURE, ksf	σ₃	1.0	3.0	5.0
γ_{dryo}	53.8	53.9	54.0	γ_{dryc}	54.5	55.4	55.8	MAX. DEVIATOR STRESS, ksf	σ₁-σ₃	10.3	11.0	11.7
S_o	69.4	69.7	70.0	S_c	100.0	100.0	100.0	ULT. DEVIATOR STRESS, ksf	σ₁-σ₃	8.5	9.0	9.4
e_o	1.472	1.468	1.461	e_c	1.439	1.401	1.384	Specimen Shape @			Sheared 	
VOID RATIO								Failure				

CONTROLLED : Strain @ 0.02 % per minute T50, Minutes = 18.0

PROCTOR TYPE : Standard, MAXIMUM DRY DENSITY, PCF : 56.6, OPTIMUM MOISTURE CONTENT, % : 48.0

REMOVED : Specimens were remolded to 95 % of maximum dry density at about 0.0 % wet of o.m.c.

SHEAR STRENGTH PARAMETERS	TOTAL		EFFECTIVE	
	COHESION, C (ksf) :	4.3	APPARENT COHESION, (ksf) :	2.6
ANGLE OF INTER. FRICTION, φ (DEGREES) :	8	ANGLE OF INTER. FRICTION, φ' (DEGREES) :	22	

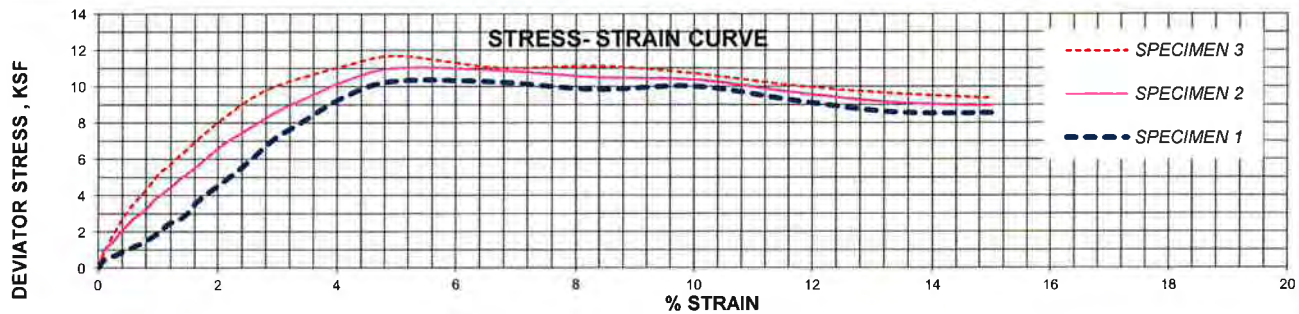
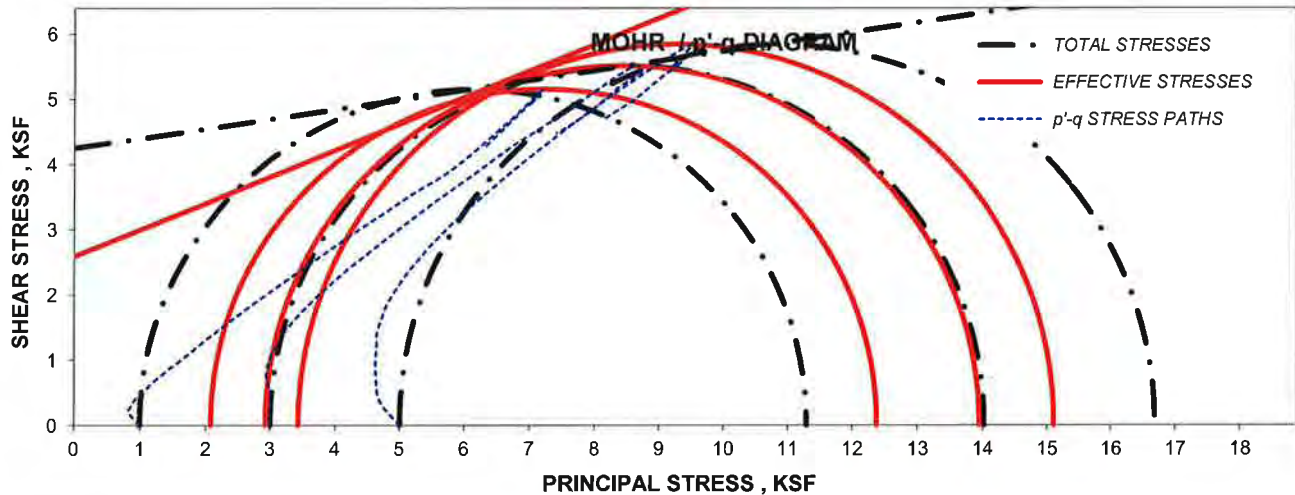

Brian Vaughan, P.E.
Technical Responsibility

Brian Vaughan
Signature

Location Coordinator
Position

06/10/14
Date



TRIAXIAL SHEAR TEST REPORT (ASTM D 4767)



REV4, 1/13/04

Project Name: Geotrack Technologies, Inc. - 14-3425-N		Report Date: 06/10/14	
Project No.: 1263-10-195		Test Date: 6/02 - 6/10/14	
Client Name: Geotrack Technologies, Inc.			
Client Address: 3620 Pelham Road, PMB #292 Greenville, SC 29615			
Boring No.: N/A	Depth / Elev.: N/A	Sample No.: 44g	Type: Bulk
Sample Location: Riverbend Pond			
Sample Description: Coal Ash			

LL, %: -	PI, %: NP	Percent Passing #200: 77.5	G_s: 2.130
-----------------	------------------	-----------------------------------	-----------------------------

SPECIMEN PROPERTIES									TEST PARAMETERS, TEST TYPE : CU/PP				
SPECIMEN NO.	INITIAL			AFTER CONSOLIDATION			SPECIMEN NO.	1	2	3			
	D _o	1	2	3	D _c	1					2	3	
DIAMETER, INCHES	D _o	2.82	2.82	2.82	D _c	2.81	2.79	2.79	B Value	0.95	0.95	0.95	
HEIGHT, INCHES	H _o	6.03	6.01	6.01	H _c	6.00	5.96	5.95	BACK PRESSURE, ksf	U _o	7.2	7.2	7.2
WATER CONTENT, %	W _o	48.0	48.0	48.0	W _c	67.6	65.8	65.0	CONFINING PRESSURE, ksf	σ ₃	1.0	3.0	5.0
DRY DENSITY, PCF	γ _{dryo}	53.8	53.9	54.0	γ _{dryc}	54.5	55.4	55.8	MAX. DEVIATOR STRESS, ksf	σ ₁ -σ ₃	10.3	11.0	11.7
SATURATION, %	S _o	69.4	69.7	70.0	S _c	100.0	100.0	100.0	ULT. DEVIATOR STRESS, ksf	σ ₁ -σ ₃	8.5	9.0	9.4
VOID RATIO	e _o	1.472	1.468	1.461	e _c	1.439	1.401	1.384	Specimen Shape @	Sheared			

CONTROLLED: Strain @ 0.02 % per minute	T50, Minutes = 18.0	
PROCTOR TYPE: Standard	MAXIMUM DRY DENSITY, PCF: 56.6	OPTIMUM MOISTURE CONTENT, %: 48.0
REMOVED: Specimens were remolded to 95 % of maximum dry density at about 0.0 % wet of o.m.c.		

SHEAR STRENGTH PARAMETERS	TOTAL		EFFECTIVE (ALT. FAILURE INTERPRETATION)	
	COHESION, C (ksf): 4.3	ANGLE OF INTER. FRICTION, Φ (DEGREES): 8	APPARENT COHESION, (ksf): 0	ANGLE OF INTER. FRICTION, Φ' (DEGREES): 39

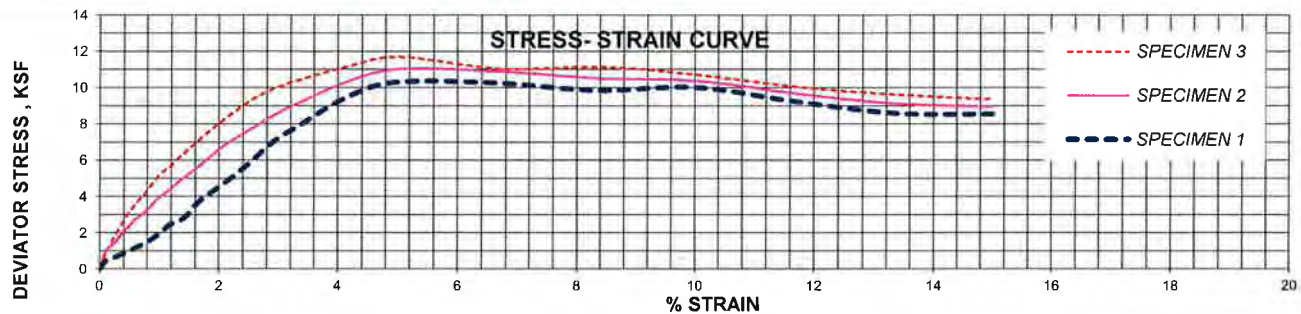
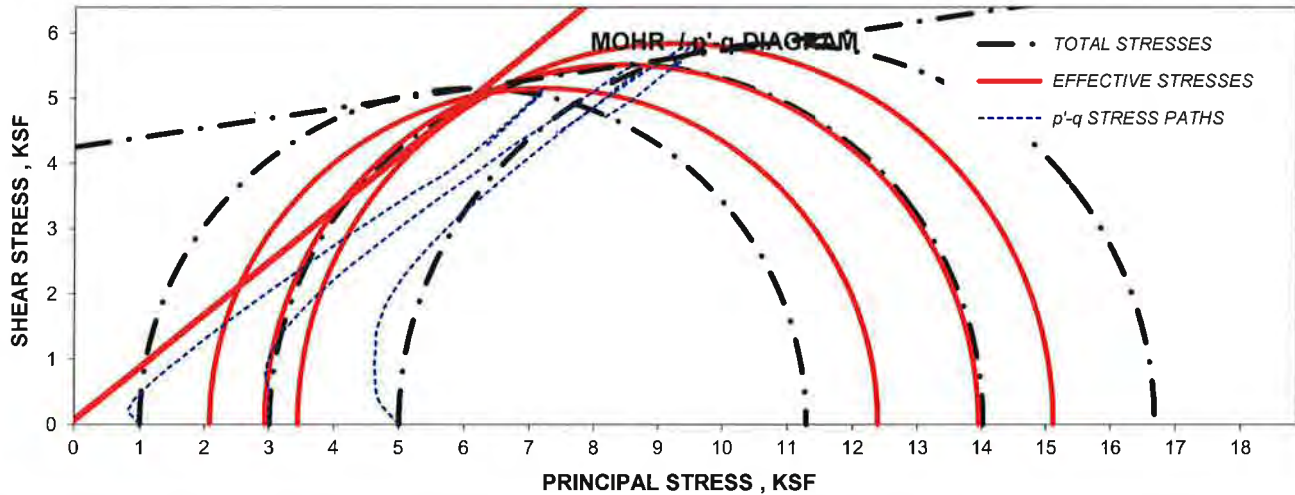

Brian Vaughan, P.E.
Technical Responsibility

Brian Vaughan
Signature

Location Coordinator
Position

06/10/14
Date

TABLE 6
Typical Values of Soil Index Properties

	Particle Size and Gradation				Voids (1)						Unit Weight (2) (lb./cu.ft.)						
	Approximate Size Range (mm)		Approx. D ₁₀ (mm)	Approx. Range Uniform Coefficient C _u	Void Ratio			Porosity (%)			Dry Weight		Wet Weight		Submerged Weight		
	D _{max}	D _{min}			e _{cr}	e _{min} dense	P _{max} loose	P _{min} dense	Min loose	100% Mod. AASHO	Max dense	Min loose	Max dense	Min loose	Max dense		
			e _{max} loose														
GRANULAR MATERIALS																	
Uniform Materials																	
a.	Equal spheres (theoretical values)	-	-	1.0	-	0.92	-	0.35	47.6	26	-	-	-	-	-	-	-
b.	Standard Ottawa SAND	0.84	0.59	1.1	0.75	0.80	0.75	0.50	44	33	92	110	93	131	57	69	
c.	Clean, uniform SAND (fine or medium)	-	-	1.2 to 2.0	0.80	1.0	0.80	0.40	50	29	83	118	84	136	52	73	
d.	Uniform, inorganic SILT	0.05	0.005	1.2 to 2.0	-	1.1	-	0.40	52	29	80	118	81	136	51	73	
Well-graded Materials																	
a.	Silty SAND	2.0	0.005	5 to 10	-	0.90	-	0.30	47	23	87	127	88	142	54	79	
b.	Clean, fine to coarse SAND	2.0	0.05	4 to 6	0.70	0.95	0.70	0.20	49	17	85	138	86	148	53	86	
c.	Micaceous SAND	-	-	-	-	1.2	-	0.40	55	29	76	120	77	138	48	76	
d.	Silty SAND & GRAVEL	100	0.005	15 to 300	-	0.85	-	0.14	46	12	89	146(3)	90	155(3)	56	92	
MIXED SOILS																	
	Sandy or Silty CLAY	2.0	0.001	10 to 30	-	1.8	-	0.25	64	20	60	135	100	147	38	85	
	Skip-graded Silty CLAY with stones or rk frags	250	0.001	-	-	1.0	-	0.20	50	17	84	140	115	151	53	89	
	Well-graded GRAVEL, SAND, SILT & CLAY mixture	250	0.001	25 to 1000	-	0.70	-	0.13	41	11	100	148(4)	125	156(4)	62	94	
CLAY SOILS																	
	CLAY (30%-50% clay sizes)	0.05	0.5/4	-	-	2.4	-	0.50	71	33	50	112	94	133	31	71	
	Colloidal CLAY (-0.002 mm: 50%)	0.01	10/8	-	-	12	-	0.60	92	37	13	106	71	128	8	66	
ORGANIC SOILS																	
	Organic SILT	-	-	-	-	3.0	-	0.55	75	35	40	110	87	131	25	69	
	Organic CLAY (30% - 50% clay sizes)	-	-	-	-	4.4	-	0.70	81	41	30	100	81	125	18	62	

See Ref 1

a height of 760 mm (30 in).

g of the falling weight onto the ding to the ground surface, the test. The free fall and height of of drill rigs use a rope wrapped the rope which then tightens on rope until the weight is visually ne the rope is released with the ggestion around the power pulley count will be obtained. Several mechanical hoist-trip device. This factors such as pushing a rock, e pressures also contribute error ducible in situ).

ow count $N \geq 100$. The log may indicating 70 blows for 150 mm ration. Large blow counts both ause rapid equipment wear and refusal" by ASTM at 100 assists g firm to better identify drilling

igate the status of cohesionless ly used in both cohesionless and types of foundations. In loose available to aid in retaining the ithout falling out of the sampler

the string of rods, the sampler lay (see Fig. 6-3a) the recovered usually immediately tested for (Fig. 6-3a) or a portable field ally stored in small glass jars mple depth, and blow count N . as necessary for sieve analyses, rg limits. The boxes of samples boratory for a stated period of

properties have been proposed. than guesses. For example, in most meaningless. The estimate

Table 6-1 Standard penetration test (SPT) correlations

Strength correlations will be given in later chapters as needed. Values shown are primarily for "order of magnitude."

Cohesionless Soil					
N	0-10	11-30	31-50	>50	
Unit weight γ , kN/m ³	12-16	14-18	16-20	18-23	
Angle of friction ϕ	25-32	28-36	30-40	>35	
State	Loose	Medium	Dense	Very dense	
Relative density D_r	see Eq. (6-3) and Eq. (6-4) since depends on $p_0 = \gamma y$				
Cohesive Soil					
N	<4	4-6	6-15	16-25	>25
Unit weight γ , kN/m ³	14-18	16-18	16-18	16-20	>20
q_u , kPa†	<25	20-50	30-60	40-200	>100
Consistency	Very soft	Soft	Medium	Stiff	Hard

$1 \text{ kn/m}^3 = 6.36 \text{ pcf}$

† Values heavily dependent on water content.

SOIL HOISTON RESIDUAL

for angle of internal friction ϕ is generally conservative, and (as noted in Chap. 13) it is common to estimate ϕ as 30 to 32° for many projects.

The relative density D_r is often related to N but is often a very poor correlation. This results from N being somewhat project- and site-dependent and from D_r being rather tenuous to define (or reliably compute). As a consequence of this and some recent work which seems promising, it was decided not to include D_r in Table 6-1, but rather provide the current "best estimate" equations.

According to Marcusson and Bieganousky (1977)

$$D_r = 0.086 + 0.0083(2311 + 222N - 711(OCR) - C_1\sigma'_v)^{1/2} \quad (6-3)$$

and according to Fardis and Veneziano (1981), who applied much of the data used to develop Eq. (6-3), the relationship is

$$\ln N = C_2 + 2.06 \ln D_r + C_3 \ln \sigma'_v \quad (6-4)$$

where $C_1 = 7.7$ for σ'_v in kPa; 53 for psi units

C_2 = depth function which should be determined at a site by measuring N and D_r †

$C_3 = 0.222$ for σ'_v in kPa; 0.442 for psi units

OCR = overconsolidation ratio defined by Eq. (11-2)

Both of these equations are based on regression analyses. Equation (6-3) is based on four dissimilar soils and a large number of tests and claims a 78 percent reliability with a ± 0.075 standard deviation.

Example 6-2 Given: the SPT blow count at a depth of 4 m is 12. The soil is very sandy with traces of gravel and has an estimated unit weight $\gamma = 17.9 \text{ kN/m}^3$. The soil is damp but above the water table.

† If no correlation is made for C_2 , use the value of $C_2 = 2.67$ obtained from the data base used for the equation.

See Ref. 2

as glacial till clays and those found in the B horizon of residual deposits, are of medium sensitivity. A few glacial clays and most fresh-water deposits are very sensitive. A few of the fresh-water and marine deposits are quick. The sensitivity of the large majority of cohesive deposits will range from 2 to 8. Sensitivities greater or less than this are much less commonly encountered. Most quick clays seem to be found (or at least reported) in Canada and Scandinavia.

13-10 EMPIRICAL METHODS FOR SHEAR STRENGTH

Numerous correlations for shear strength or shear strength parameters have been proposed in the literature. Several will be presented here to illustrate some of those available.

One of the earliest correlations is that between the SPT (Sec. 6-9) and the unconfined compression strength, as was illustrated in Table 6-1.

Correlations between ϕ and plasticity index I_p are shown in Fig. 13-20. A relationship between ϕ and percent clay fraction (Skempton, 1964) is shown in Fig. 13-21. Both of these curves should be used cautiously, as there are several major exceptions which can be found in the literature as well as substantial scatter in the data points used to establish the curves. For routine soil work, however, particularly in regions where w_L is on the order of 20 to 45 and I_p on the order of 15 to 30, these curves will be reasonably reliable.

ATTACHMENT E

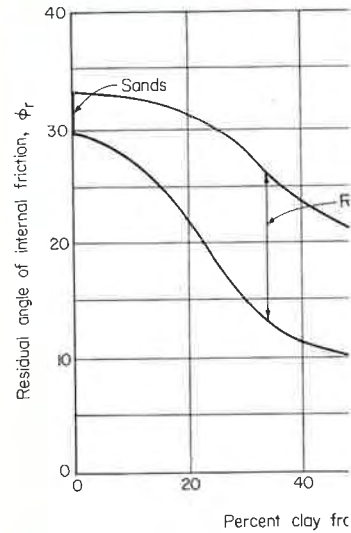

Figure 13-21 Correlation between residual angle of internal friction, ϕ_r , and percent clay fraction, 1964.)

Figure 13-22 illustrates the shear strength of soft to very soft soils. It can be made for statistical determination of test pits.

Figure 13-23 (also Fig. 6) can be used in test pits or where a person can be lowered into the soil. It works well in any fine-grained soil, free location, pushes the piston into the soil.



Figure 13-22 The torvane.

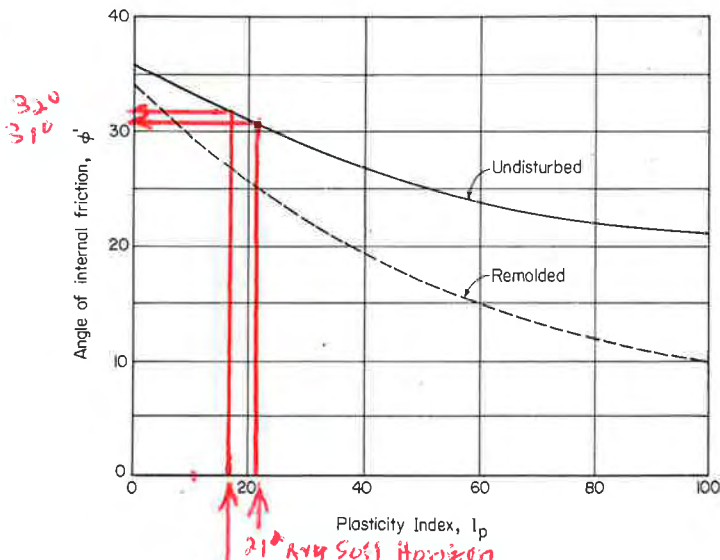

Figure 13-20 Correlation between angle of internal friction ϕ' (true) and plasticity index for both undisturbed and remolded soil. (After Bjerrum and Simons, 1960.)

See Ref. 2

TABLE 1
Typical Properties of Compacted Soils

Group Symbol	Soil Type	Range of Maximum Dry Unit Weight, pcf	Range of Optimum Moisture, Percent	Typical Value of Compression		Typical Strength Characteristics				Typical Coefficient of Permeability ft./min.	Range of CBR Values	Range of Subgrade Modulus k lbs./sq.in. ψ si/ft
				At 1.4 taf (20 psi)	At 3.6 taf (50 psi)	Cohesion (as compacted) pcf	Cohesion (saturated) pcf	(Effective Stress Envelope Degrees)	Tan θ			
				Percent of Original Height								
GW	Well graded clean gravels, gravel-sand mixtures.	125 - 135	11 - 8	0.3	0.6	0	0	>38	>0.79	5×10^{-2}	40 - 80	300 - 500
GP	Poorly graded clean gravels, gravel-sand mix	115 - 125	14 - 11	0.4	0.9	0	0	>37	>0.74	10^{-1}	30 - 60	250 - 400
GM	Silty gravels, poorly graded gravel-sand-silt.	120 - 135	12 - 8	0.5	1.1	>34	>0.67	$>10^{-6}$	20 - 60	100 - 400
GC	Clayey gravels, poorly graded gravel-sand-clay.	115 - 130	14 - 9	0.7	1.6	>31	>0.60	$>10^{-7}$	20 - 40	100 - 300
SW	Well graded clean sands, gravelly sands.	110 - 130	16 - 9	0.6	1.2	0	0	38	0.79	$>10^{-3}$	20 - 40	200 - 300
SP	Poorly graded clean sands, sand-gravel mix.	100 - 120	21 - 12	0.8	1.4	0	0	37	0.74	$>10^{-3}$	10 - 40	200 - 300
SM	Silty sands, poorly graded sand-silt mix.	110 - 125	16 - 11	0.8	1.6	1050	420	34	0.67	$5 \times >10^{-5}$	10 - 40	100 - 300
SM-SC	Sand-silt clay mix with slightly plastic fines.	110 - 130	15 - 11	0.8	1.4	1050	300	33	0.66	$2 \times >10^{-6}$	5 - 30	100 - 300
SC	Clayey sands, poorly graded sand-clay-mix.	105 - 125	19 - 11	1.1	2.2	1550	230	31	0.60	$5 \times >10^{-7}$	5 - 20	100 - 300
ML	Inorganic silts and clayey silts.	95 - 120	24 - 12	0.9	1.7	1400	190	32	0.62	$>10^{-5}$	15 or less	100 - 200
ML-CL	Mixture of inorganic silt and clay.	100 - 120	22 - 12	1.0	2.2	1350	460	32	0.62	$5 \times >10^{-7}$
CL	Inorganic clays of low to medium plasticity.	95 - 120	24 - 12	1.3	2.5	1800	270	28	0.54	$>10^{-7}$	15 or less	50 - 200
OL	Organic silts and silty clays, low plasticity.	80 - 100	33 - 21	5 or less	50 - 100
MH	Inorganic clayey silts, elastic silts.	70 - 95	40 - 24	2.0	3.8	1500	420	25	0.47	$5 \times >10^{-7}$	10 or less	50 - 100
CH	Inorganic clays of high plasticity	75 - 105	36 - 19	2.6	3.9	2150	230	19	0.35	$>10^{-7}$	15 or less	50 - 150
OH	Organic clays and silty clays	65 - 100	45 - 21	5 or less	25 - 100

- Notes:
- All properties are for condition of "Standard Proctor" maximum density, except values of k and CBR which are for "modified Proctor" maximum density.
 - Typical strength characteristics are for effective strength envelopes and are obtained from USBR data.
 - Compression values are for vertical loading with complete lateral confinement.
 - (>) indicates that typical property is greater than the value shown.
(..) indicates insufficient data available for an estimate.

See Ref. 4

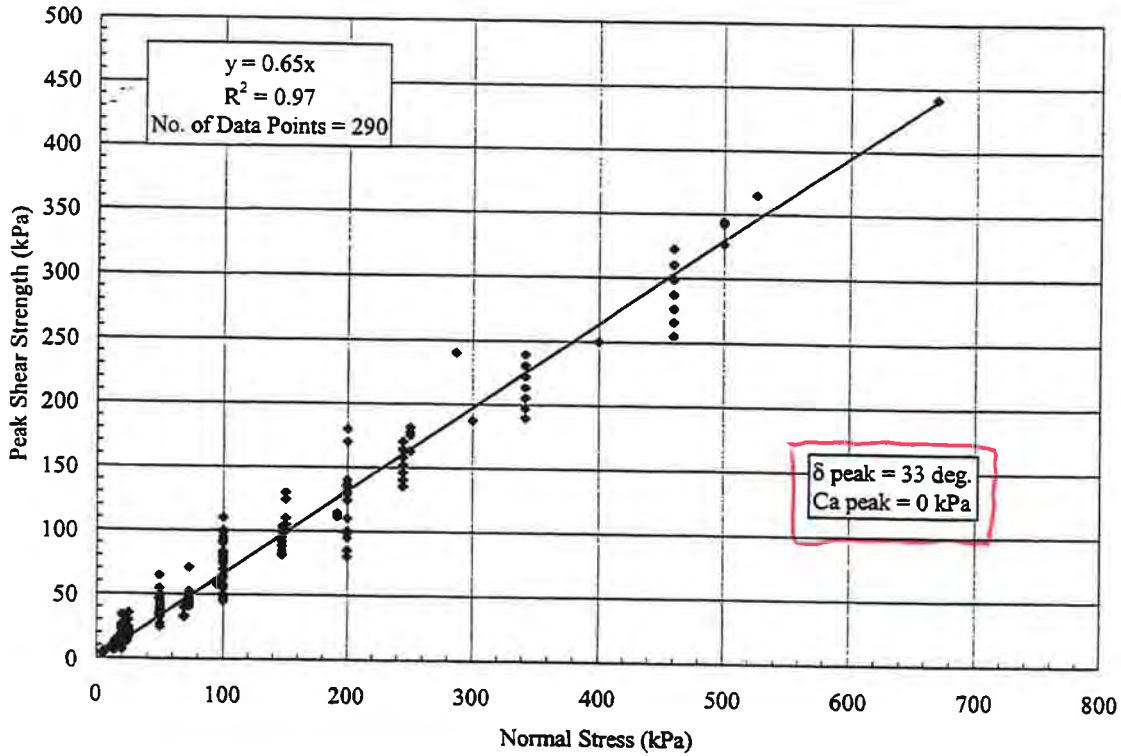

Appendix Figure 8a – Peak Shear Strength; NW-NP Geotextile against Granular Soil.

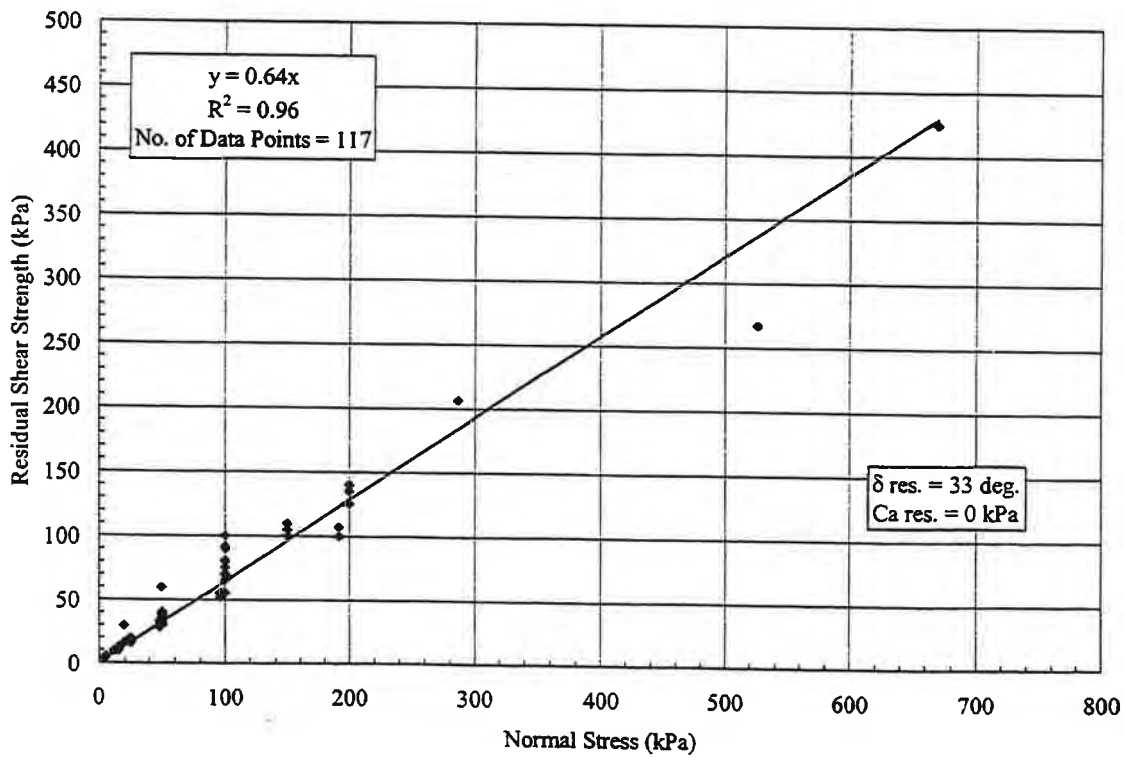

Appendix Figure 8b – Residual Shear Strength; NW-NP Geotextile against Granular Soil.

See Ref. 5

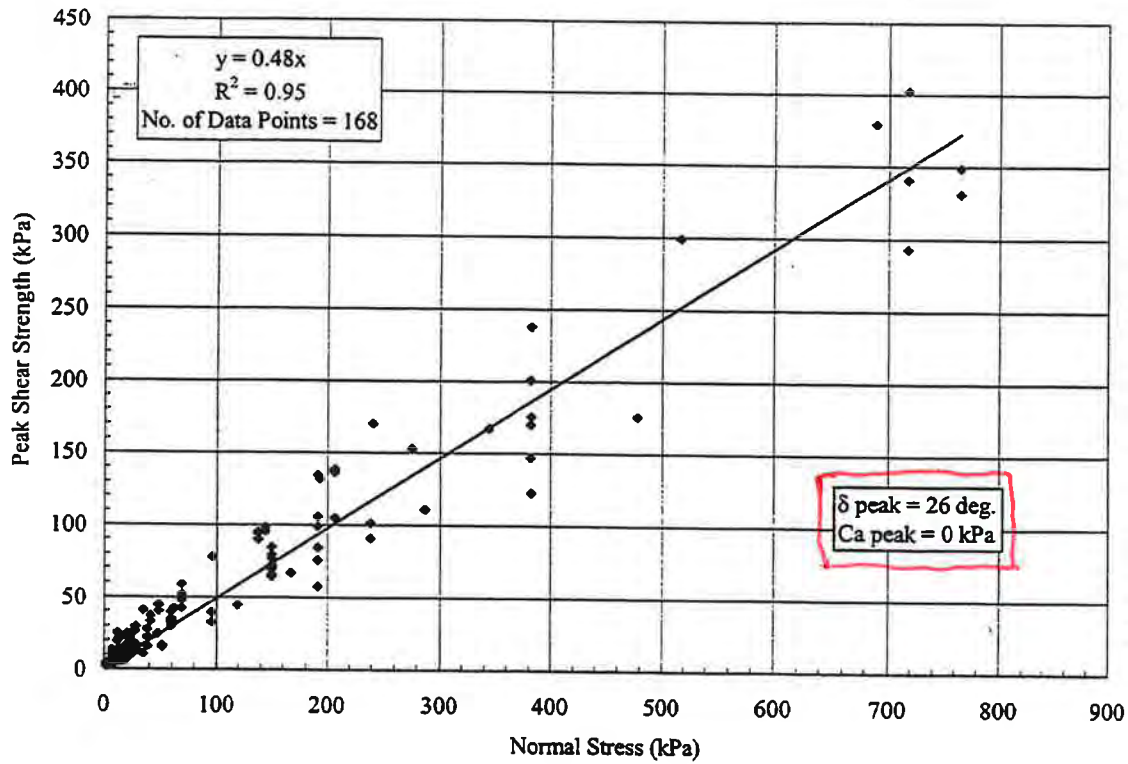

Appendix Figure 2i – Peak Shear Strength; Textured HDPE against NW-NP Geotextile on a Drainage Geocomposite.

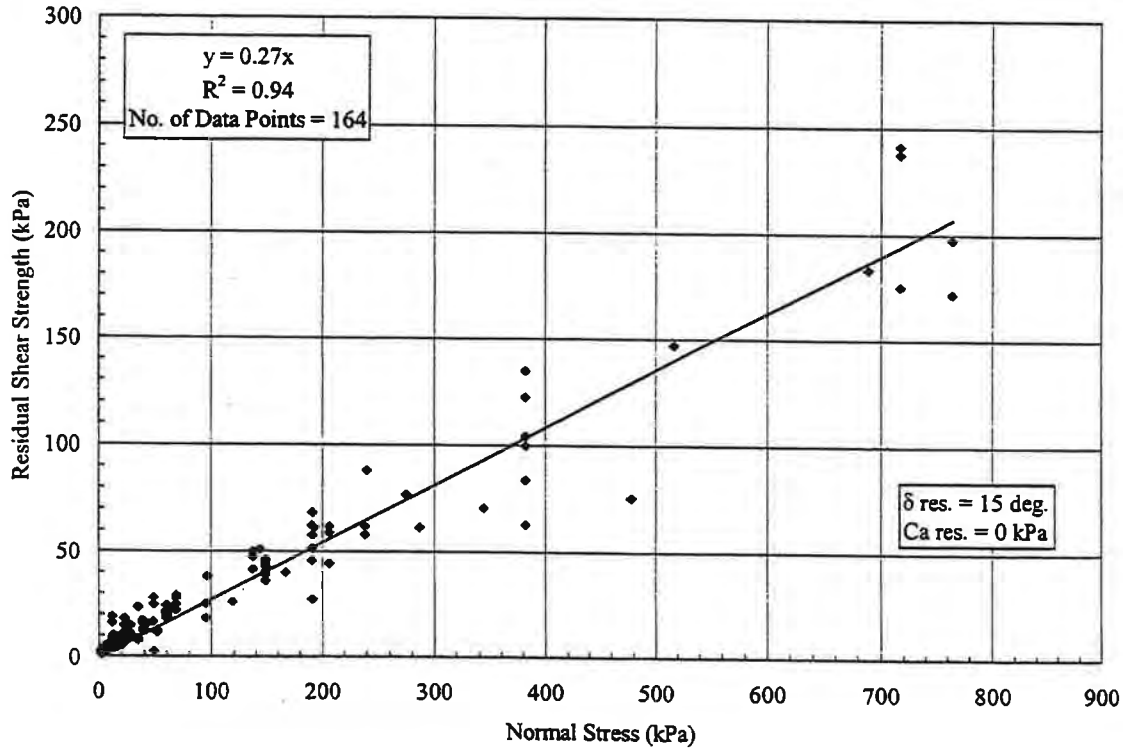

Appendix Figure 2j – Residual Shear Strength; Textured HDPE against NW-NP Geotextile on a Drainage Geocomposite.

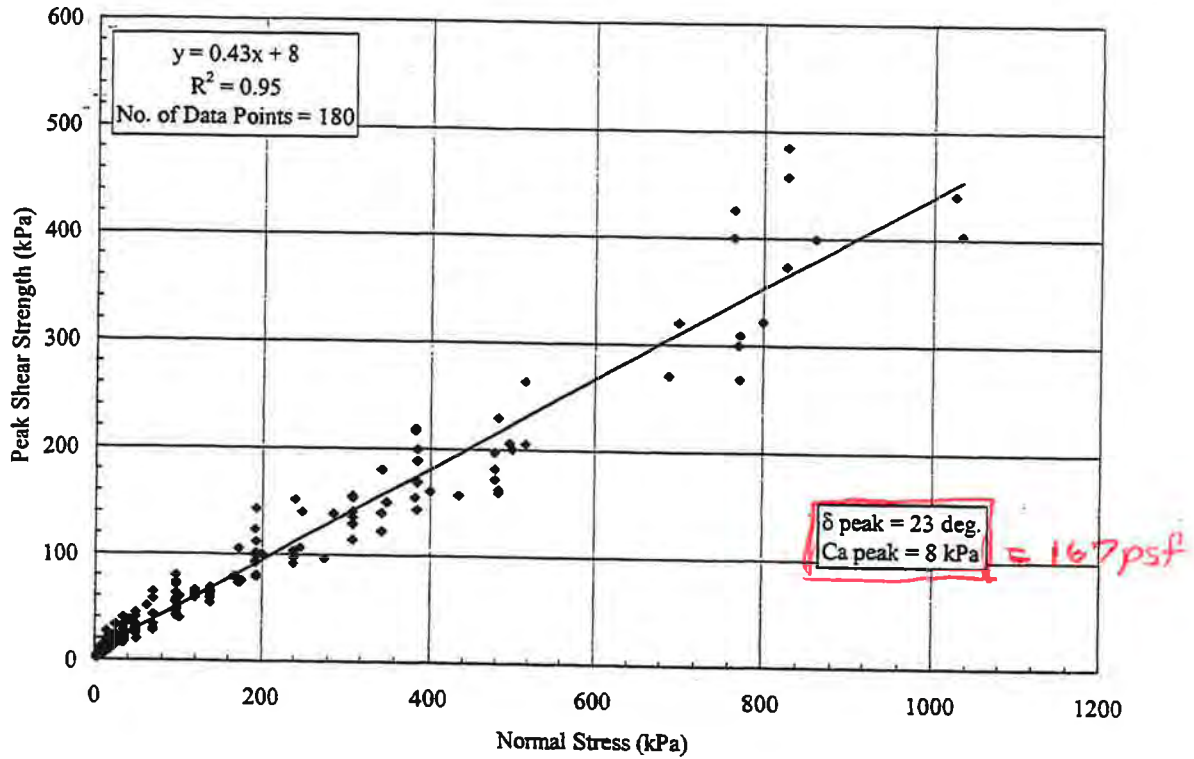

Appendix Figure 11a - Peak Shear Strength; Textured HDPE against NW-NP Side of Fabric-Reinforced GCL.

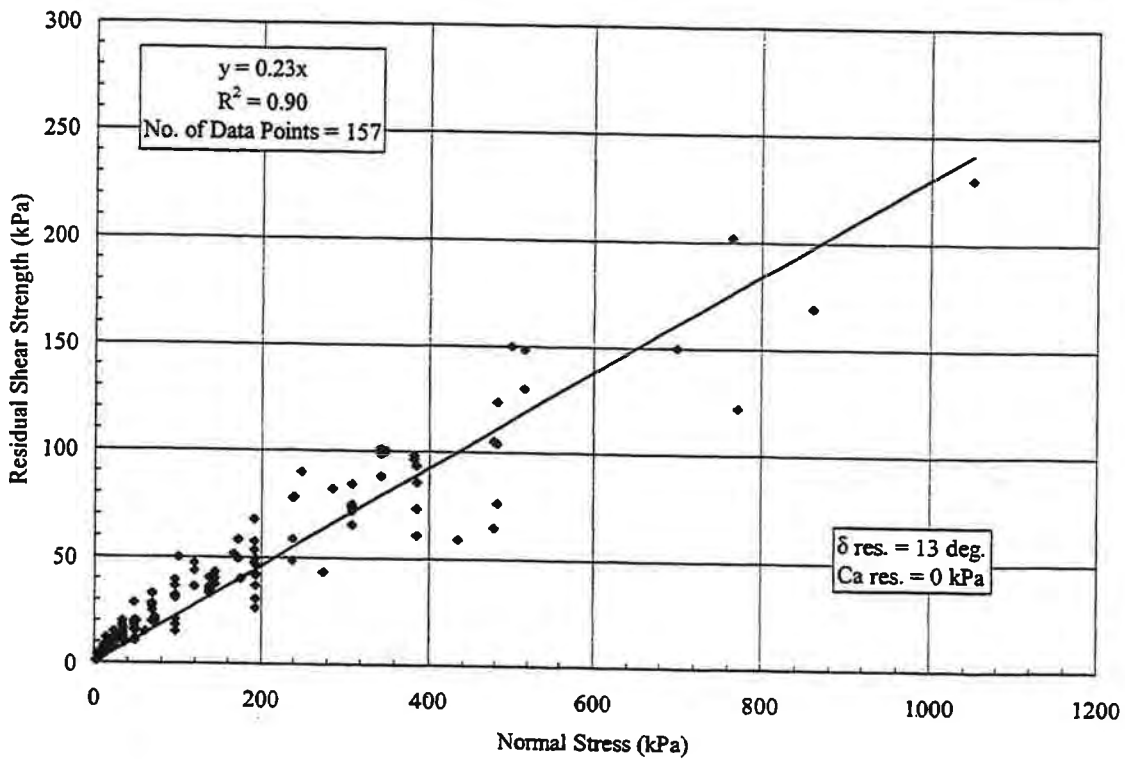

Appendix Figure 11b - Residual Shear Strength; Textured HDPE against NW-NP Side of Fabric-Reinforced GCL.

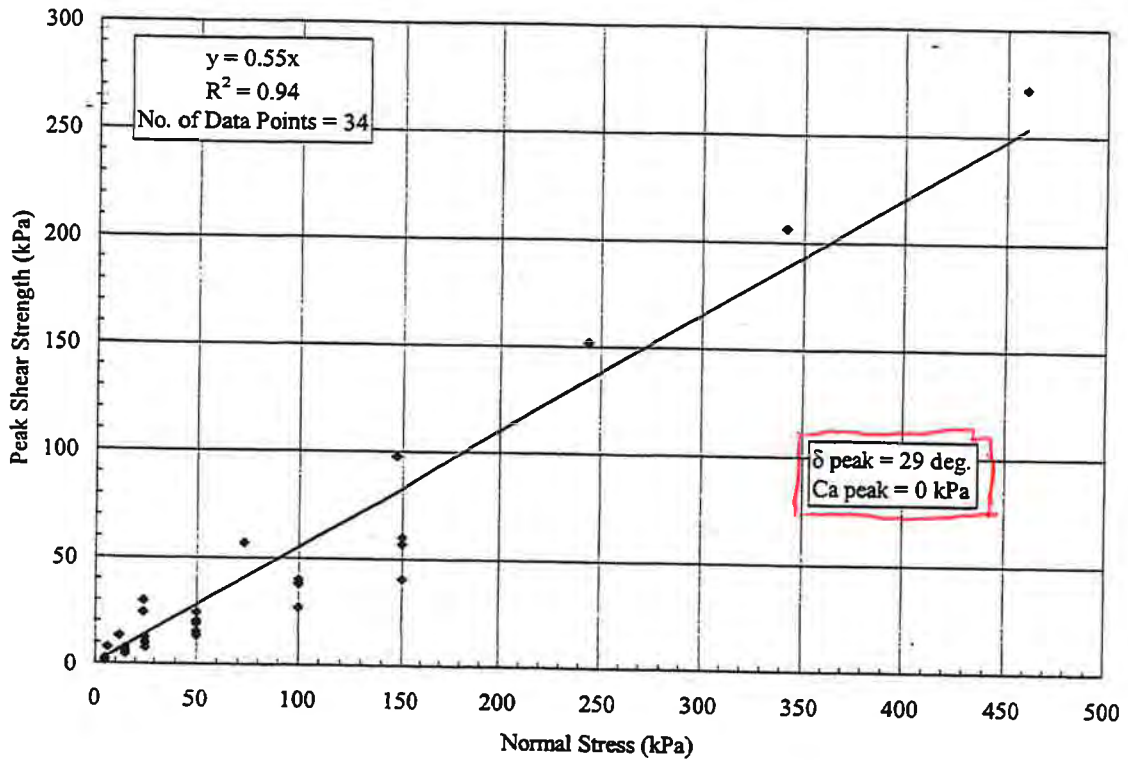

Appendix Figure 9e - Peak Shear Strength; Woven Geotextile against Cohesive Soil.

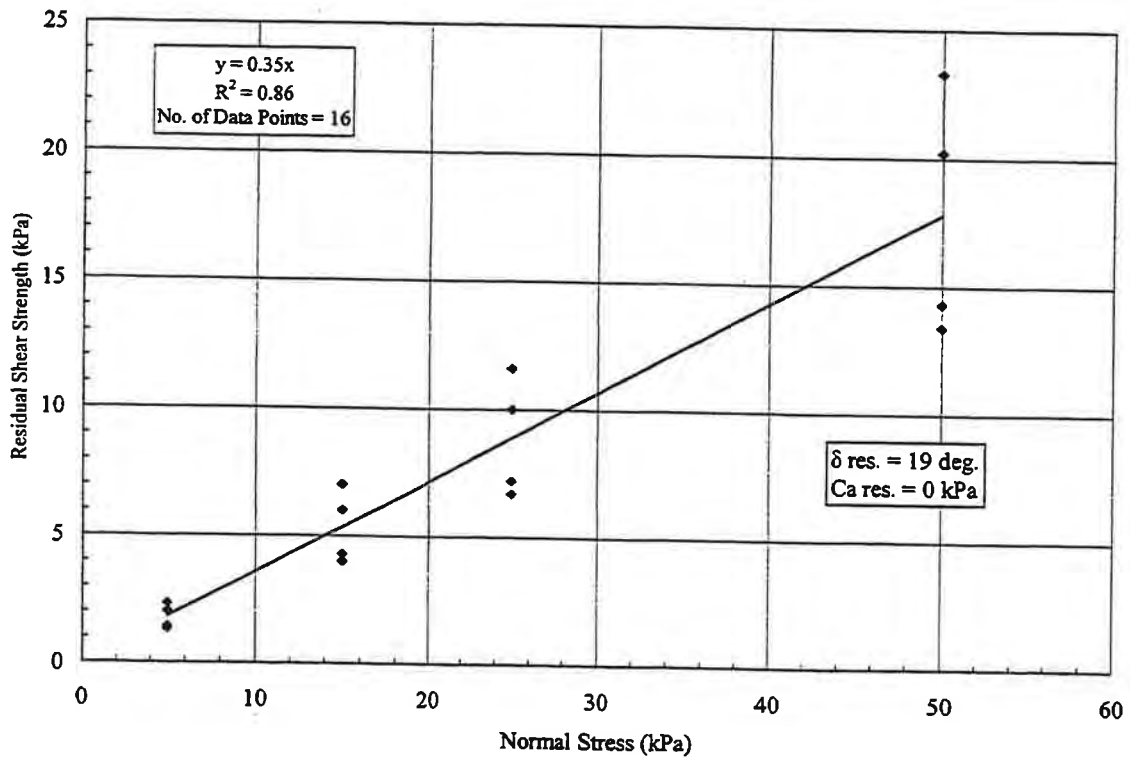

Appendix Figure 9f - Residual Shear Strength; Woven Geotextile against Cohesive Soil.

ATTACHMENT I



LEGEND

EXISTING BOUNDARY
EXISTING ROAD

CRITICAL STABILITY SECTION



COLON MINE SITE STRUCTURAL FILL
SANFORD, NC

PROJECT NUMBER: M.D. PLUMMER, S.E.
DATE: 9/19/14

PROJECT NUMBER

DATE: 9/19/14

DESCRIPTION

HOK Engineering Inc.
a hok company
442 S. Cherry St. Suite 1000
Charlotte, NC 28202-3075
Tel: 704.376.1444 Fax: 704.376.1445

PROPOSED FINAL CLOSURE PLAN

SCALE: 1" = 200'

PLANNING: 00C-02.dwg
SHEET: 00C-02

DATE: 9/19/14

ATTACHMENT K6



Earthquake Hazards Program

US Seismic Hazard 2008

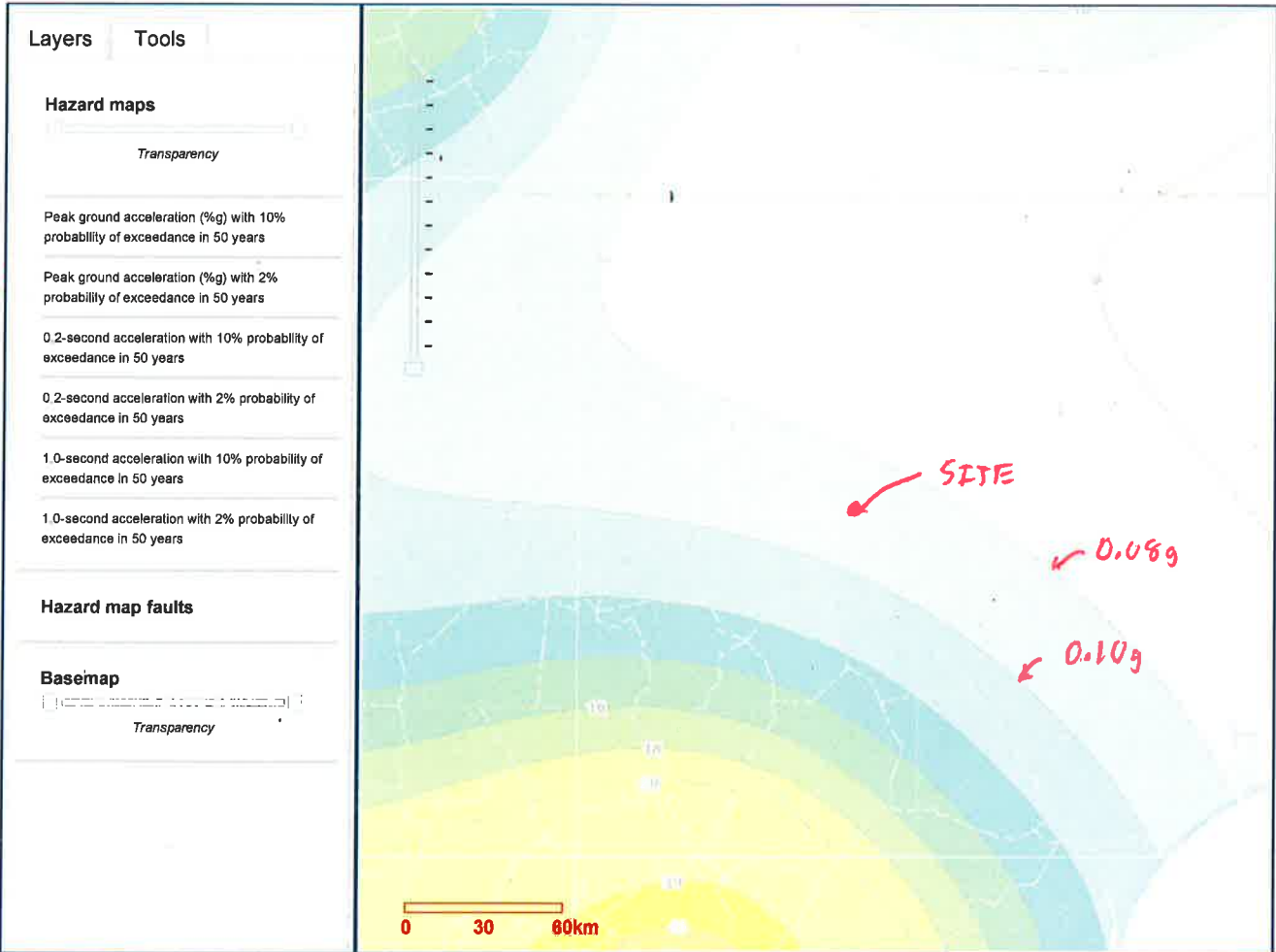

*

Share this page: [Facebook](#) [Twitter](#) [Google](#) [Email](#)

This page intentionally left blank.

HDR Computation

Job Number	453925-235691-018	No.	
Project	Charah Colon Mine	Computed	TMY
Subject	Permit Application	Checked	KP
Task	Final Cover Veneer Stability (Option 1)	Sheet	1
		Date	10/27/2014
		Date	10/29/2014
		Of	3

Objective: Determine the smallest interface friction angle allowable to meet dynamic and static factors of safety for final cover stability due to sliding for Option 1 final cover (see second page of calc.)

References:

1. Matasovic, N. (1991), "Selection of Method for Seismic Slope Stability Analysis," Proc. 2nd International Conference on Recent Advances in Geotechnical Earthquake Engineering and Soil Dynamics, St. Louis, Vol. 2, pp. 1057-1062.
2. Koerner, G.R. and D. Narejo (2005). Direct Shear Database of Geosynthetic-to-Geosynthetic and Geosynthetic-to-Soil Interfaces. GRI Report #30.

Calculations:

Infinite slope:

$$FS = \frac{\text{Resisting Moment (RM)}}{\text{Driving Moment (DM)}}$$

$$FS = \frac{\left(\frac{c}{\gamma z \cos^2 \beta} \right) + \tan \phi \left(1 - \gamma_w \frac{z - d_w}{\gamma z} \right) - k_g \tan \beta \tan \phi}{k_g + \tan \beta}$$

Given:

γ =	120	lb/ft ³
γ_w =	62.4	lb/ft ³
z =	4.0	ft
Slope, M =	4	H:1V
c =	0.0	lb/ft ²
Depth to Water =	2.50	ft
Ground surface acceleration =	0.09	(seismic coefficient)
Ground surface acceleration =	0	(static)

Where:

- FS = Factor of Safety
- k_g = seismic coefficient (=0 for static stability)
- γ = unit weight of cover soil
- c = cohesion of cover soil
- γ_w = unit weight of water
- z = depth to failure surface
- d_w = depth to seepage surface (=z if slope is dry)
- β = slope angle of cover
- ϕ = interface friction angle

Assume lateral seepage is contained within lower 18" layer of higher permeability soil in final cover.

USGS National Seismic Hazards Map - 2008 showing peak horizontal acceleration with a 2% probability of exceedance in 50 years. See Attachment A.

HDR Computation

Job Number	453925-235691-018	No.	
Project	Charah Colon Mine	Computed	TMY
Subject	Permit Application	Checked	KP
Task	Final Cover Veneer Stability (Option 1)	Sheet	2
		Date	10/27/2014
		Date	10/29/2014
		Of	3

Solution:

$\beta = 14.04$ degrees

Dynamic Conditions ($k_g = 0.09$)

Dynamic FS Against Sliding: (EPA Guidance Document EPA/600/R-95/051 - RCRA Subtitle D (258) Seismic Design Guidelines for MSW Landfill Facilities page 102 requires a minimum factor of safety of 1.0)

$FS_{min} = 1.0$ Dynamic conditions

ϕ (°)	RM	DM	FS
5	0.068	0.340	0.20
10	0.138	0.340	0.41
15	0.210	0.340	0.62
20	0.285	0.340	0.84
23.4	0.339	0.340	1.00 ← CRITICAL
30	0.452	0.340	1.33
35	0.548	0.340	1.61

Static Conditions ($k_g = 0$)

Static FS Against Sliding:

$FS_{min} = 1.5$ Static conditions

ϕ (°)	RM	DM	FS
5	0.070	0.250	0.28
10	0.142	0.250	0.57
15	0.216	0.250	0.86
20	0.293	0.250	1.17
25	0.375	0.250	1.50 ← CRITICAL
30	0.465	0.250	1.86
35	0.564	0.250	2.25

HDR Computation

Job Number	453925-235691-018	No.	
Project	Charah Colon Mine	Computed	TMY
Subject	Permit Application	Checked	KP
Task	Final Cover Veneer Stability (Option 1)	Sheet	3
		Date	10/27/2014
		Date	10/29/2014
		Of	3

Conclusion:

A minimum interface friction angle of 25 degrees between the components of the final cover system is necessary for stability.

Determine if components of proposed final cover system are capable of achieving the minimum friction angle using typical values of ϕ for each interface from Attachment B (Ref. 2).

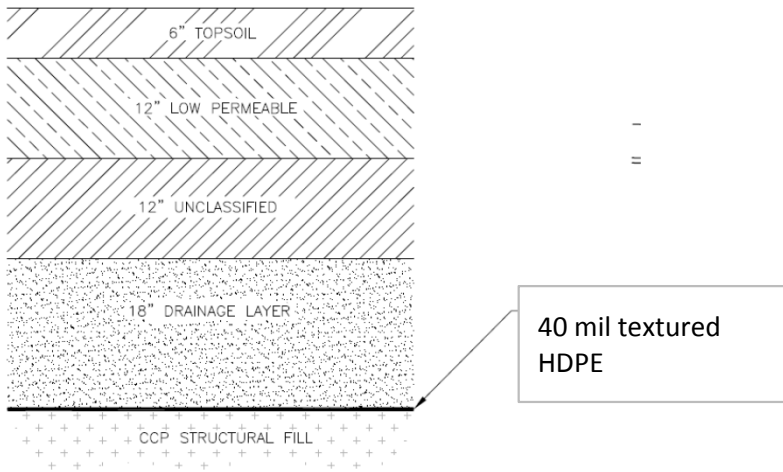

Textured Geomembrane/Granular Soil: $\phi = 34^\circ$, $c = 0$ psf

From the typical values above, the proposed materials to be used for final cover construction are capable of achieving the minimum required friction angle. This should be verified, however, with project specific lab testing.

This page intentionally left blank.

HDR Computation

Job Number	453925-235691-018	No.	
Project	Charah Colon Mine	Computed	TMY
Subject	Permit Application	Checked	KP
Task	Final Cover Veneer Stability (Option 2)	Sheet	1
		Date	10/22/2014
		Date	10/29/2014
		Of	3

Objective: Determine the smallest interface friction angle allowable to meet dynamic and static factors of safety for final cover stability due to sliding for Option 2 final cover (see second page of calc.)

References:

1. Matasovic, N. (1991), "Selection of Method for Seismic Slope Stability Analysis," Proc. 2nd International Conference on Recent Advances in Geotechnical Earthquake Engineering and Soil Dynamics, St. Louis, Vol. 2, pp. 1057-1062.
2. Koerner, G.R. and D. Narejo (2005). Direct Shear Database of Geosynthetic-to-Geosynthetic and Geosynthetic-to-Soil Interfaces. GRI Report #30.

Calculations:

Infinite slope:

$$FS = \frac{\text{Resisting Moment (RM)}}{\text{Driving Moment (DM)}}$$

$$FS = \frac{\left(\frac{c}{\gamma z \cos^2 \beta} \right) + \tan \phi \left(1 - \gamma_w \frac{z - d_w}{\gamma z} \right) - k_g \tan \beta \tan \phi}{k_g + \tan \beta}$$

Given:

γ =	120	lb/ft ³
γ_w =	62.4	lb/ft ³
z =	4.0	ft
Slope, M =	4	H:1V
c =	0.0	lb/ft ²

Depth to Water = 4.00 ft

Ground surface acceleration =	0.09	(seismic coefficient)
Ground surface acceleration =	0	(static)

Where:

- FS = Factor of Safety
- k_g = seismic coefficient (=0 for static stability)
- γ = unit weight of cover soil
- c = cohesion of cover soil
- γ_w = unit weight of water
- z = depth to failure surface
- d_w = depth to seepage surface (=z if slope is dry)
- β = slope angle of cover
- ϕ = interface friction angle

Assume lateral seepage is contained within geocomposite.

USGS National Seismic Hazards Map - 2008 showing peak horizontal acceleration with a 2% probability of exceedance in 50 years. See Attachment A.

HDR Computation

Job Number	453925-235691-018	No.	
Project	Charah Colon Mine	Computed	TMY
Date	10/22/2014	Checked	KP
Subject	Permit Application	Date	10/29/2014
Task	Final Cover Veneer Stability (Option 2)	Sheet	2
		Of	3

Solution:

$\beta = 14.04$ degrees

Dynamic Conditions ($k_g = 0.09$)

Dynamic FS Against Sliding: (EPA Guidance Document EPA/600/R-95/051 - RCRA Subtitle D (258) Seismic Design Guidelines for MSW Landfill Facilities page 102 requires a minimum factor of safety of 1.0)

$FS_{min} = 1.0$ Dynamic conditions

ϕ (°)	RM	DM	FS
5	0.086	0.340	0.25
10	0.172	0.340	0.51
15	0.262	0.340	0.77
19.2	0.340	0.340	1.00 ← CRITICAL
25	0.456	0.340	1.34
30	0.564	0.340	1.66
35	0.684	0.340	2.01

Static Conditions ($k_g = 0$)

Static FS Against Sliding:

$FS_{min} = 1.5$ Static conditions

ϕ (°)	RM	DM	FS
5	0.087	0.250	0.35
10	0.176	0.250	0.71
15	0.268	0.250	1.07
20.5	0.374	0.250	1.50 ← CRITICAL
25	0.466	0.250	1.87
30	0.577	0.250	2.31
35	0.700	0.250	2.80

HDR Computation

Job Number	453925-235691-018	No.	
Project	Charah Colon Mine	Computed	TMY
Subject	Permit Application	Checked	KP
Task	Final Cover Veneer Stability (Option 2)	Sheet	3
		Date	10/22/2014
		Date	10/29/2014
		Of	3

Conclusion:

A minimum interface friction angle of 20.5 degrees between the components of the final cover system is necessary for stability.

Determine if components of proposed final cover system are capable of achieving the minimum friction angle using typical values of ϕ for each interface from Attachment B (Ref. 2).

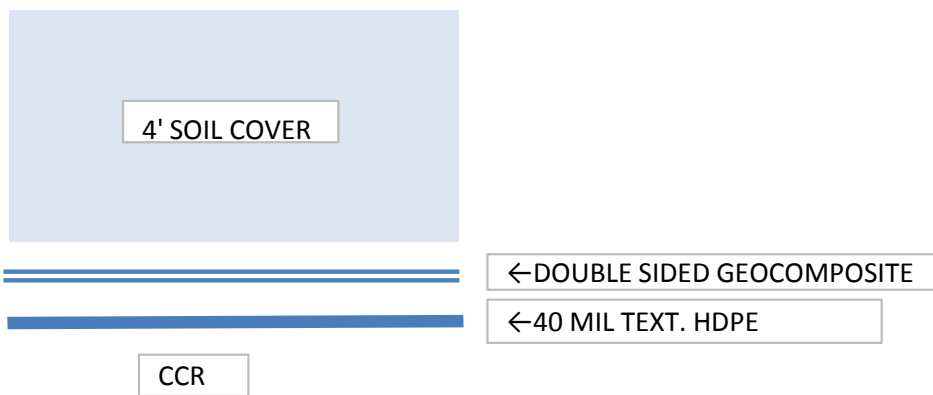

- Textured Geomembrane/Granular Soil: $\phi = 34^\circ$, $c = 0$ psf
- Textured Geomembrane/Geocomposite: $\phi = 26^\circ$, $c = 0$ psf
- Geocomposite/Soil Cover: $\phi = 30^\circ$, $c = 104$ psf

From the typical values above, the proposed materials to be used for final cover construction are capable of achieving the minimum required friction angle. This should be verified, however, with project specific lab testing.

This page intentionally left blank.

ATTACHMENT A



Earthquake Hazards Program

US Seismic Hazard 2008

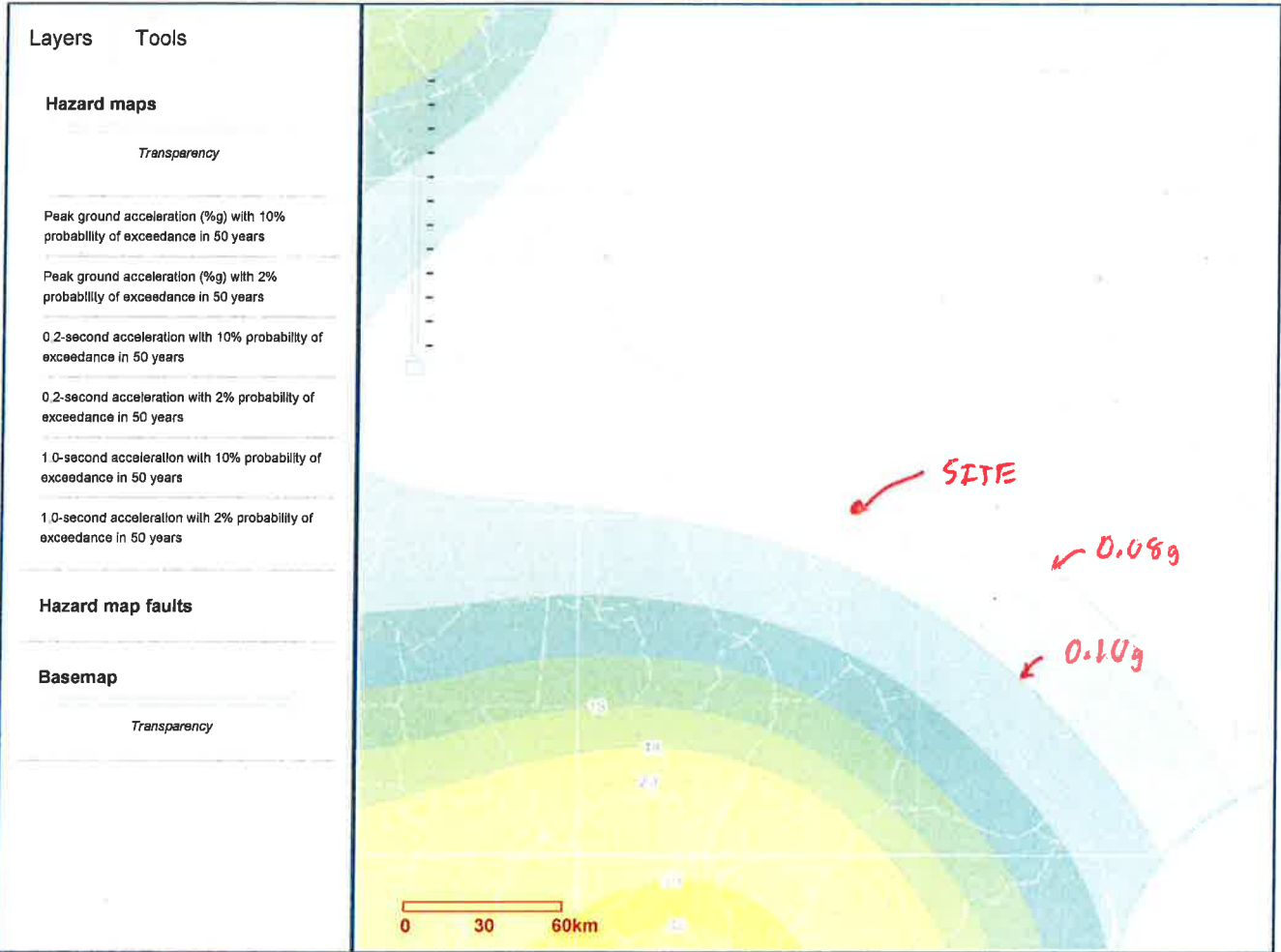

Share this page: [Facebook](#) [Twitter](#) [Google](#) [Email](#)

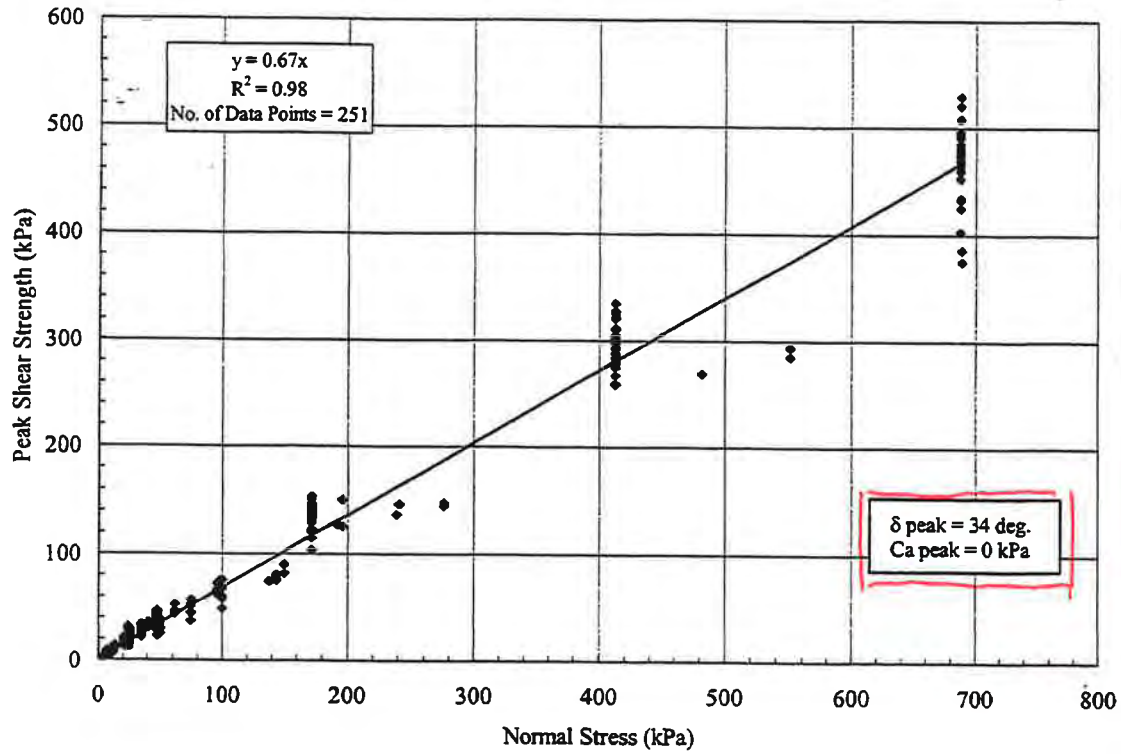

Appendix Figure 2a – Peak Shear Strength; Textured HDPE against Granular Soil.

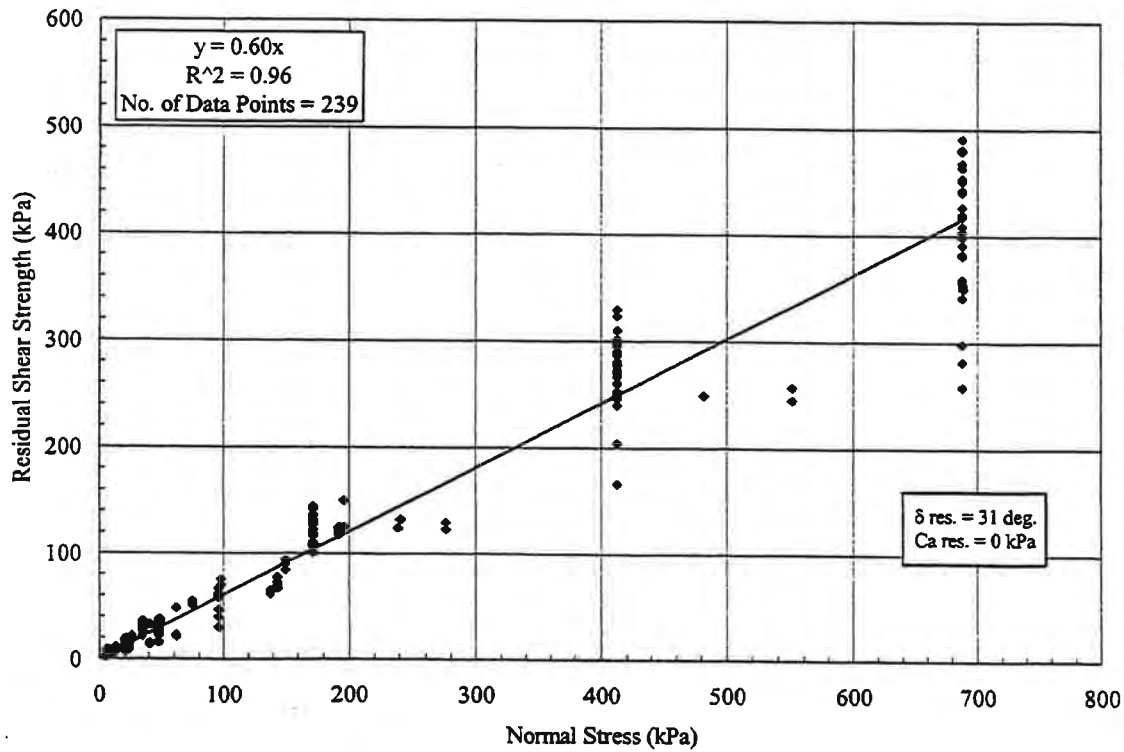

Appendix Figure 2b – Residual Shear Strength; Textured HDPE against Granular Soil.

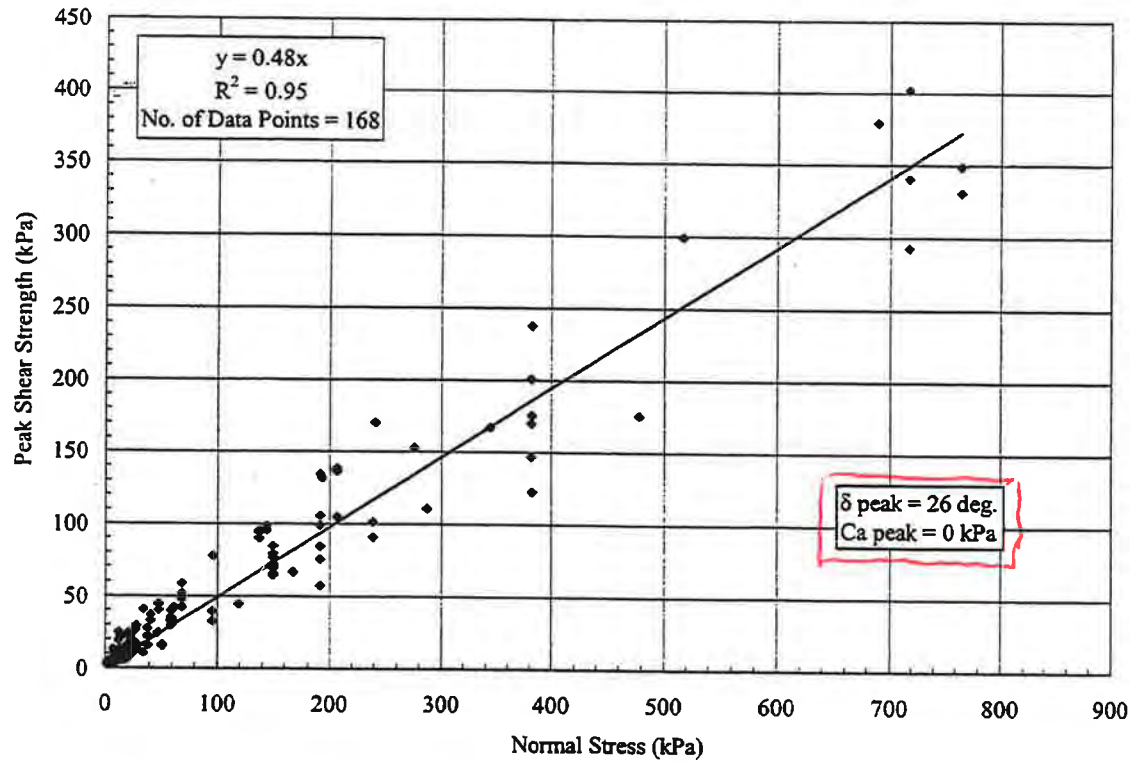

Appendix Figure 2i – Peak Shear Strength; Textured HDPE against NW-NP Geotextile on a Drainage Geocomposite.

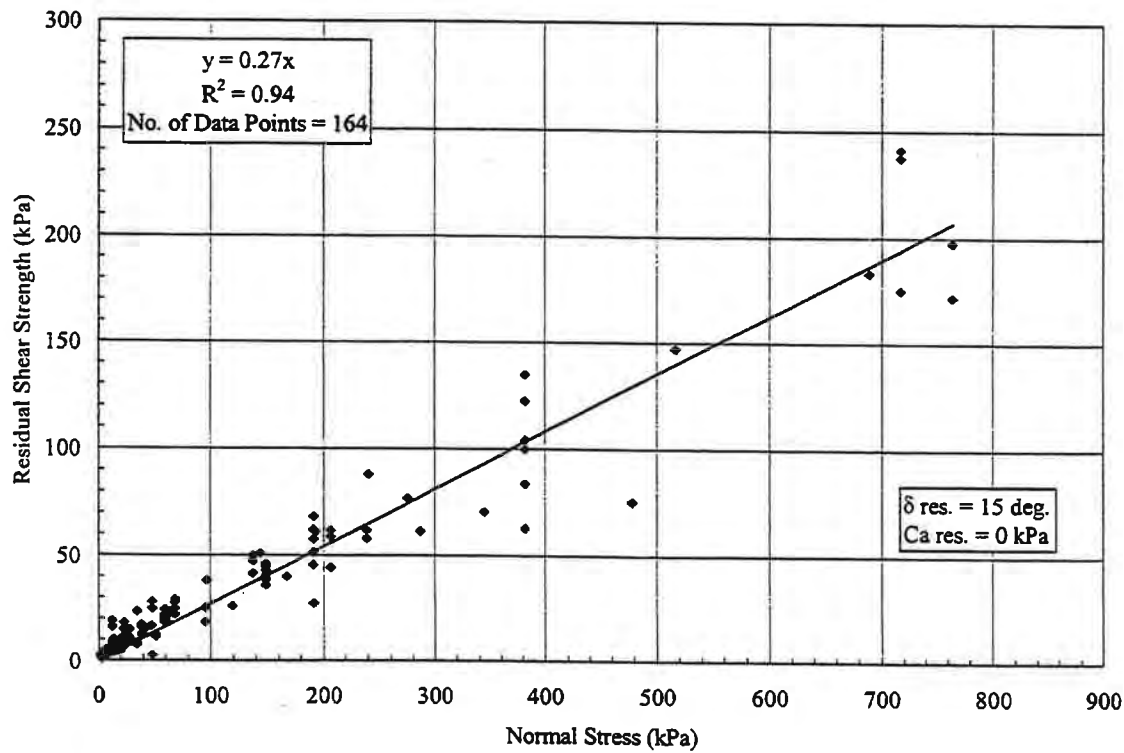

Appendix Figure 2j – Residual Shear Strength; Textured HDPE against NW-NP Geotextile on a Drainage Geocomposite.

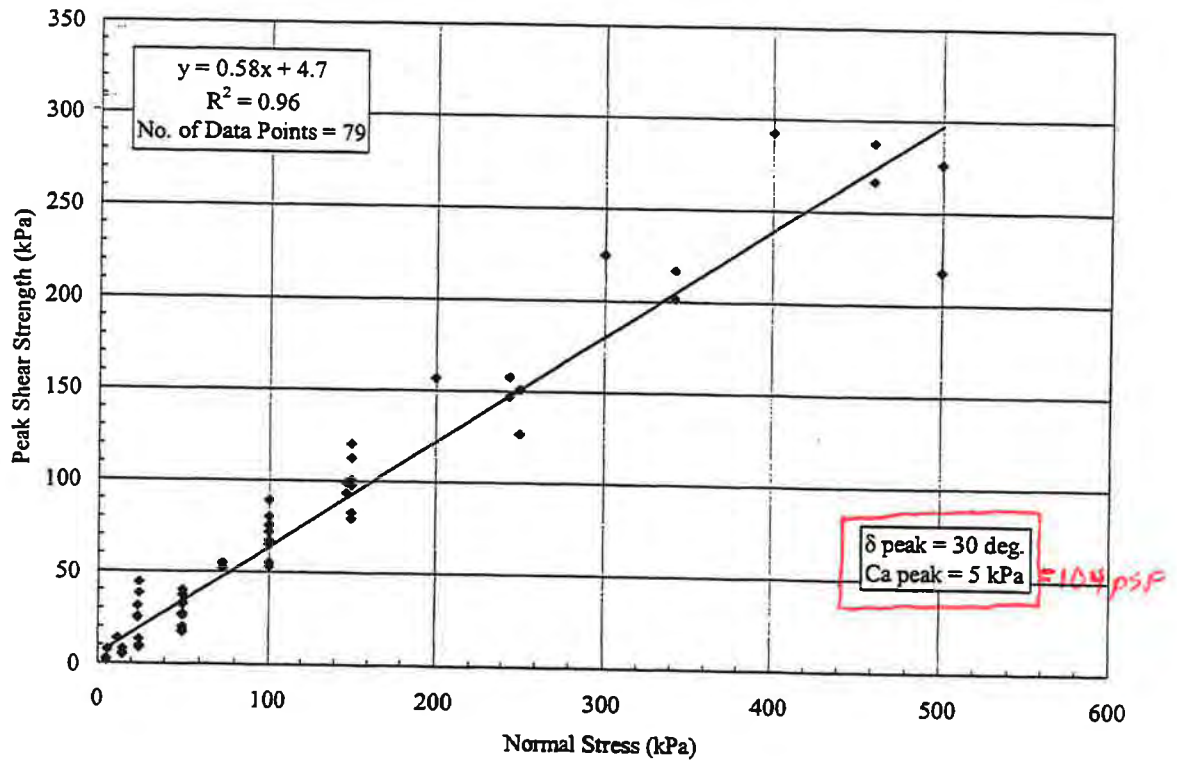

Appendix Figure 9a - Peak Shear Strength; NW-NP Geotextile against Cohesive Soil.

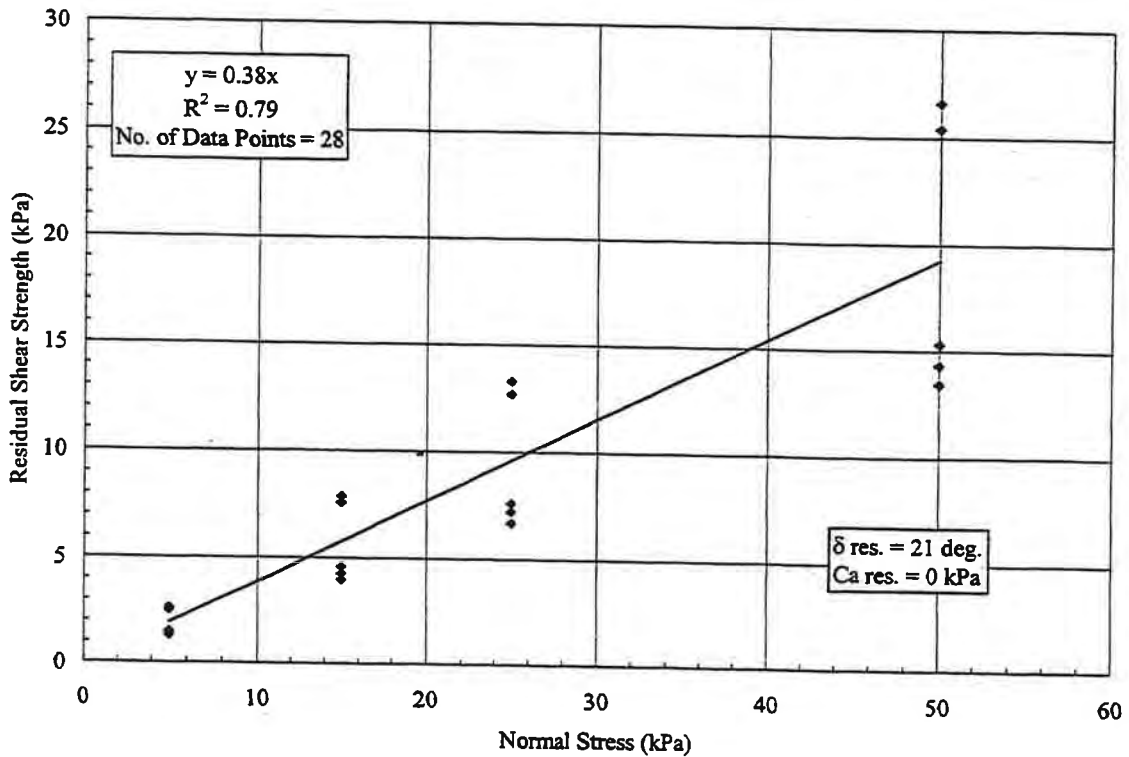

Appendix Figure 9b - Residual Shear Strength; NW-NP Geotextile against Cohesive Soil.

HDR Computation

Job Number	453925-235691-018	No.	
Project	Charah Colon Mine	Computed	TMY
Subject	Permit Application	Checked	KP
Task	Operational Cover Stability	Sheet	1
		Date	10/1/2014
		Date	10/29/2014
		Of	3

Objective: Determine the operational cover stability due to sliding for a 3H:1V slope.

- References:**
1. "Designing with Geosynthetics"; Robert M. Koerner
 2. "Cover Soil Slope Stability Involving Geosynthetic Interfaces", GRI Report #18
 3. Slope Stability Analyses, Charah Colon Mine Structural Fill Permit Application, HDR 2014

Calculations: Finite Slope Analysis

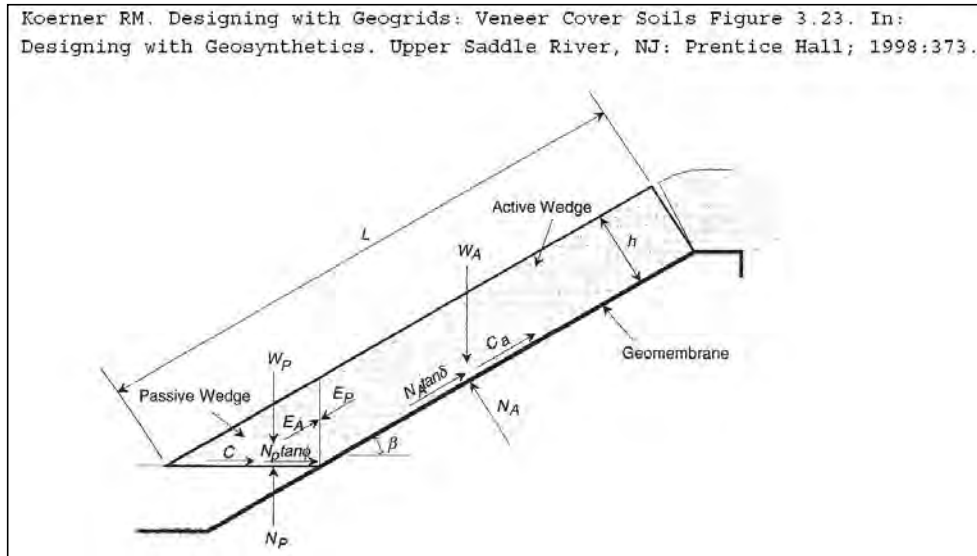

Active:

$$W_A = \gamma h^2 \left(\frac{L}{h} - \frac{1}{\sin \beta} - \frac{\tan \beta}{2} \right)$$

$$N_A = W_A \cos \beta$$

$$C_a = c_a \left(L - \frac{h}{\sin \beta} \right)$$

$$a = (W_A - N_A \cos \beta) \cos \beta$$

$$b = -[(W_A - N_A \cos \beta) \sin \beta \tan \phi + (N_A \tan \delta + C_a) \sin \beta \cos \beta + \sin \beta (C + W_p \tan \phi)]$$

$$c = (N_a \tan \delta + C_a) \sin^2 \beta \tan \phi$$

$$FS = \frac{-b + \sqrt{b^2 - 4ac}}{2a}$$

Passive:

$$W_p = \frac{\gamma h^2}{\sin 2\beta}$$

$$C = \frac{ch}{\sin \beta}$$

HDR Computation

Job Number	453925-235691-018	No.	
Project	Charah Colon Mine	Computed	TMY
Subject	Permit Application	Checked	KP
Task	Operational Cover Stability	Sheet	2
		Date	10/1/2014
		Date	10/29/2014
		Of	3

Where:

- W_A = total weight of active wedge
- W_p = total weight of passive wedge
- N_A = effective force normal to the failure plane of the active wedge
- γ = unit weight of cover soil
- h = thickness of cover soil
- L = length of slope measured along the geosynthetic
- β = soil slope angle beneath the geosynthetic
- ϕ = friction angle of cover soil
- δ = minimum allowable interface friction angle between slope liner system components
- c_a = minimum allowable adhesive force between slope liner system components
- C = cohesive force along the failure plane of the passive wedge
- c = cohesion of cover soil

Given:

Slope, M =	3	H:1V	
Max Structural Fill Depth, H =	34.0	ft	(Measurement taken near southwest corner of main fill)
c_a =	0	lb/ft ²	(Conservatively assume = 0)
c =	0	lb/ft ²	(Assume = 0 to account for potential development of tension cracks)

Solution:

L =	107.5	ft
β =	18.4	degrees

Operational Cover Soil Condition (Assume 24" of CCR will be placed over bottom liner prior to general filling)

Inputs	h =	2	ft	
	γ =	83.8	lb/ft ³	(Fly ash wet density based on 100% standard Proctor compaction, See Ref. 3)
	ϕ =	22.0	degrees	(Based on triaxial tests on compacted fly ash, effective stress conditions, see Ref. 3)
	δ =	22.0	degrees	(Adjust to obtain minimum allowable FS = 1.3, see Note below)

Outputs	W_A =	16,899.3	lb/ft
	N_A =	16,035.3	lb/ft
	C_a =	0.0	lb/ft
	W_p =	559.6	lb/ft
	C =	0.0	lb/ft
	a =	1,597.7	lb/ft
	b =	-2,226.5	lb/ft
	c =	260.8	lb/ft

FS = 1.3

Note: A minimum Factor of Safety of 1.3 is required as recommended by Reference 2 for temporary slopes in non-hazardous waste landfills.

HDR Computation

Job Number	453925-235691-018	No.	
Project	Charah Colon Mine	Computed	TMY
		Date	10/1/2014
Subject	Permit Application	Checked	KP
		Date	10/29/2014
Task	Operational Cover Stability	Sheet	3
		Of	3

Conclusion:

Based on the inputs used, the operational cover soil consisting of 24" of fly ash will be acceptable as long as the geosynthetic components of the bottom liner system achieve a minimum friction angle of 22 ° (conservatively neglecting cohesion along the interface). The slope stability calculations for the project (Ref. 3) indicate that the critical interface (Geocomposite/Textured HDPE) friction angle for the proposed bottom liner design using typical values for similar materials is 26 °. Therefore, the stability of the operational cover over the proposed bottom liner design should not be an issue. The unit weight and friction angle of the material placed on the sideslope as well as the frictional properties of the geosynthetic materials must be confirmed with the assumptions in this calculation.

This page intentionally left blank.

C

Geosynthetics

Geosynthetic Stresses
Design Anchor Trench



This page intentionally left blank.

HDR Computation

Job Number 453925-235691-018

No.

Project Charah Colon Mine

Computed TMY

Date 10/2/2014

Subject Permit Application

Checked KP

Date 10/29/2014

Task Geosynthetic Stresses

Sheet 1

Of 1

Objective: Determine the stresses in the geosynthetics of the base liner system.

- References:**
1. Sharma, H. D., & Lewis, S. P. (1994). *Waste Containment Systems, Waste Stabilization, and Landfills: Design and Evaluation*. New York: John Wiley & Sons, Inc.
 2. Koerner, G.R., & Narejo, D. (2005). *Direct Shear Database of Geosynthetic-t0-Geosynthetic and geosynthetic-to-Soil Interfaces*, GRI Report #30.
 3. HDR (2014). Slope Stability Analyses, Charah Colon Mine Structural Fill Permit Application.

Layer	Material	Thickness (in)	Tensile Strength (lbs/in)*	Allowable Stress (psi)	Assumed Allowable stress, σ , psi	Interface Friction		Factor of Safety, Due to:			
						Between surfaces (Ref. 2 - see Attachment A)	ϕ	Self Weight	Operational Cover	Waste	Operational Equipment
Geocomposite	GSE PermaNet UL Geocomposite	0.34	100	294	294	Between Nonwoven, needle-punched Geotextile and Textured HDPE	26	No Stress	No Stress	No Stress	No Stress
Geomembrane	GSE HD Textured	0.06	126	2,100	2,100	Between Textured HDPE and Nonwoven, needle-punched Geotextile of the GCL	23	No Stress	No Stress	No Stress	No Stress
GCL	GSE BentoLiner CNSL Data Sheet	0.3	40	133	133	Between Nonwoven Needle-punched Geotextile and Clay Subgrade beneath GCL	29	No Stress	No Stress	No Stress	No Stress

Input Parameters

Sideslopes =	3 H:1V	Geotextile Thickness, t_{GTEX} =	0.02 in	0.002 ft (assumed)
Sideslope Angle, β =	18.43 °	Geonet Thickness, t_{GNET} =	0.3 in	0.03 ft
Max Slope Height, H =	24 ft	GCL Thickness, t_{GCL} =	0.3 in	0.03 ft
Density of water, ρ_w =	62.4 lbs/ft ³			
Geomembrane Thickness, t_{GMB} =	0.06 in			
Geotextile Mass per Unit Area =	8 oz/yd ² =	0.005 ft		
		0.06 lb/ft ²		
			12 in/ft	
			144 oz/yd ² per lb/ft ²	

* Use yield strength for geomembrane.

Results/Conclusions:

The results indicate that for each condition evaluated, there will be no stress developed within the geosynthetics. The frictional resistance between the materials will therefore be sufficient to resist the forces developed during construction and structural fill construction without stressing the components. This is compatible with standard liner system design practices.

This page intentionally left blank.

HDR Computation

Job Number	453925-235691-018	No.
------------	-------------------	-----

Project	Charah Colon Mine	Computed	TMY	Date	10/2/2014
Subject	Permit Application	Checked	KP	Date	10/29/2014
Task	Geosynthetic Stresses - Stress Due to Self Weight	Sheet	1	Of	3

Case 1: Stress Due to Self Weight

$$W = \frac{SG \gamma_w t (1 \times H)}{\sin \beta} \quad \text{Ref. 1, Page 394}$$

$$\sigma_{TA} = \frac{W \sin \beta - F}{1 \times t} \quad \text{Ref. 1, Page 394}$$

$$F = W_{\text{Total}} \cos \beta \tan \delta \quad \text{Ref. 1, Page 395} \quad \text{Factor of Safety, FS} = \frac{\sigma_y (\text{allowable})}{\sigma_{TA}}$$

Where:

- W = geomembrane weight
- SG = specific gravity of geomembrane
- γ_w = unit weight of water 62.4 lb/ft³
- σ_{TA} = Applied Tensile Stress
- β = slope
- F = interface frictional strength between geomembrane and underlying material
- t = geomembrane thickness
- δ = interface friction angle between geomembrane and underlying material
- H = slope height

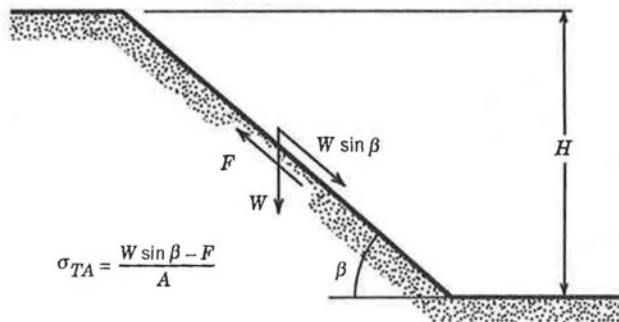

Figure 8.12 Free-body diagram for geomembrane self-weight calculations.

Source of Figure 8.12:
Ref. 1, Page 395

$$\text{Length of Slope, } L = \frac{H}{\sin \beta}$$

$$H = 34 \text{ feet}$$

$$L = 107.5 \text{ feet}$$

$$\rho_{\text{water}} = 1,000 \text{ kg/m}^3$$

$$\rho_{\text{water}} = 1.0 \text{ g/cm}^3$$

$$SG = \frac{\rho_{\text{sample}}}{\rho_{\text{water}}}$$

Conversions

0.000001 m ³ /cm ³
1000 g/kg
144 in ² /ft ²

- Where: SG = Specific Gravity
- ρ_{sample} = Density of Sample
- ρ_{water} = Density of Water

$$W = \rho Va$$

- Where: W = Weight
- ρ = Density
- V = Volume
- a = Acceleration

$$9.81 \text{ m/s}^2$$

$$V = L(1 \times t)$$

HDR Computation

Job Number	453925-235691-018	No.
------------	-------------------	-----

Project	Charah Colon Mine	Computed	TMY	Date	10/2/2014
Subject	Permit Application	Checked	KP	Date	10/29/2014
Task	Geosynthetic Stresses - Stress Due to Self Weight	Sheet	2	Of	3

Sideslope Angle, $\beta = 18.43^\circ$

	Geocomposite*	Geomembrane	GCL**	Geotextile	Geonet
Density, ρ (g/cm ³)		0.94			0.94
Specific Gravity, SG (Unitless)		0.94			0.94
Weight, W (lbs)	169.61	31.53	120.23	5.97	157.66
Thickness, t (ft)	0.03	0.005	0.03		0.03
$\sigma_{\text{Allowable}}$ (psi)	294	2,100	133		

*Weight of Geocomposite is equal to the weight of the geonet plus the weight of the geotextiles on either side of the geonet.

**The weight of the GCL is determined from the weight of a roll (2,600 lbs) divided by the surface area of the roll (2,325 ft²) to get a pound per ft². The pound per ft² is multiplied by a 1 foot wide by length of the slope strip to determine the weight of the geotextile.

Interface	Range of δ (°)	Source & Description	Actual δ (°)	
$\delta_{\text{Soil - Geocomposite}}$	22 - 40	Ref 2 Figure 13a: Nonwoven, needle-punched Geotextile vs Granular Soil	27	(not applicable for self weight calcs.)
$\delta_{\text{Geocomposite - Geomembrane}}$	15 - 33	Ref 2 Figure 2i: Nonwoven, needle-punched Geotextile vs Textured HDPE	26	
$\delta_{\text{Geomembrane - GCL}}$	15 - 33	Ref 2 Figure 11a: Nonwoven, needle-punched Geotextile (top of hydrated GCL) vs Textured HDPE	23	
$\delta_{\text{GCL - Clay Soil Liner}}$	15 - 28	Ref 2 Figure 9e: Woven geotextile (bottom of GCL) vs Clay Soil	29	

Geocomposite - Geomembrane Interface

$$W = W_{\text{geocomposite}}$$

$$W = 169.61 \text{ lb}$$

$$\text{Geocomposite thickness, } t_{\text{GT}} = 0.03 \text{ ft}$$

$$\delta = 26 \text{ degrees}$$

$$F = 78 \text{ lb}$$

$$\sigma_{\text{Actual}} = -877 \text{ lb/ft}^2$$

$$\sigma_{\text{Actual}} = -6 \text{ psi}$$

$$\sigma_{\text{Allowable}} = 294 \text{ psi}$$

FS = No Stress

Geomembrane - GCL Interface

$$W = W_{\text{geomembrane}} + W_{\text{geocomposite}}$$

$$W = 201.14 \text{ lb}$$

$$\text{Geomembrane thickness, } t_{\text{GM}} = 0.01 \text{ ft}$$

$$\delta = 23 \text{ degrees}$$

$$F = 81 \text{ lb/ft}$$

$$\sigma_{\text{Actual}} = -3,478 \text{ lb/ft}^2$$

$$\sigma_{\text{Actual}} = -24 \text{ psi}$$

$$\sigma_{\text{Allowable}} = 2,100 \text{ psi}$$

FS = No Stress

HDR Computation

Job Number	453925-235691-018	No.	
Project	Charah Colon Mine	Computed	TMY
Subject	Permit Application	Checked	KP
Task	Geosynthetic Stresses - Stress Due to Self Weight	Sheet	3
		Date	10/2/2014
		Date	10/29/2014
		Of	3

GCL - Clay Soil Liner Interface

$$W = W_{\text{geomembrane}} + W_{\text{geocomposite}} + W_{\text{GCL}}$$

$W = 321.38 \text{ lb/ft}$
 GCL thickness, $t_{\text{GCL}} = 0.03 \text{ ft}$
 $\delta = 29 \text{ degrees}$
 $F = 169 \text{ lb/ft}$
 $\sigma_{\text{Actual}} = -2,695 \text{ lb/ft}^2$
 $\sigma_{\text{Actual}} = -19 \text{ psi}$
 $\sigma_{\text{Allowable}} = 133 \text{ psi}$

FS = No Stress

This page intentionally left blank.

HDR Computation

Job Number	453925-235691-018	No.
------------	-------------------	-----

Project	Charah Colon Mine	Computed	TMY	Date	10/2/2014
Subject	Permit Application	Checked	KP	Date	10/29/2014
Task	Geosynthetic Stresses - Stress Due to Operational Cover	Sheet	1	Of	2

Case 2: Stress due to Operational Cover

Operational Cover Density, ρ_{OC} = 84 lb/ft³ (fly ash wet density based on 100% standard Proctor compaction, See Ref. 3)
 Operational Cover Thickness, t_{OC} = 24 in (assumes 2' protective layer of ash will be placed over liner prior to general filling)

$$F_D = W \sin\beta \quad \text{Driving Force}$$

$$F_R = W \cos\beta \tan\delta_L \quad \text{(frictional force)}$$

$$\text{Tension} = F_D - F_R \quad \text{lb/ft} \quad 144 \text{ in}^2/\text{ft}^2$$

$$\text{Stress} = \text{Tension}/t/144 \text{ psi} \quad 12 \text{ in/ft}$$

Geocomposite - Geomembrane Interface

$$W = W_{\text{Geocomposite}} \text{ from Self Weight + Operational Cover over length of slope}$$

$$170 \text{ lb/ft } W_{\text{Geocomposite}} \text{ from Self Weight}$$

$$18,020 \text{ lb/ft Operational Cover over length of slope}$$

$$W = 18,190 \text{ lb/ft}$$

Geocomposite thickness, t_{GT} = 0.03 ft

$$\delta_L = 26 \text{ degrees}$$

$$F_D = 5,752 \text{ lb/ft}$$

$$F_R = 8,416 \text{ lb/ft}$$

$$T_{\text{Geocomposite}} = 0 \text{ lb/ft}$$

$$\sigma_{\text{Actual}} = 0 \text{ psi}$$

$$\sigma_{\text{Allowable}} = 294 \text{ psi}$$

FS = No Stress

Geomembrane - GCL Interface

$$W = W_{\text{Geocomposite}} + W_{\text{Geomembrane}} \text{ from Self Weight + Operational Cover over length of slope}$$

$$201 \text{ lb/ft } W_{\text{Geocomposite}} + W_{\text{geomembrane}} \text{ from Self Weight}$$

$$18,020 \text{ lb/ft Operational Cover over length of slope}$$

$$W = 18,221 \text{ lb/ft}$$

Geomembrane thickness, t_{GM} = 0.01 ft

$$\delta_L = 23 \text{ degrees}$$

$$F_D = 5,762 \text{ lb/ft}$$

$$F_R = 7,337 \text{ lb/ft}$$

$$T_{\text{Geomembrane}} = 0 \text{ lb/ft}$$

$$\sigma_{\text{Actual}} = 0 \text{ psi}$$

$$\sigma_{\text{Allowable}} = 2,100 \text{ psi}$$

FS = No Stress

HDR Computation

Job Number	453925-235691-018	No.
------------	-------------------	-----

Project	Charah Colon Mine	Computed	TMY	Date	10/2/2014
Subject	Permit Application	Checked	KP	Date	10/29/2014
Task	Geosynthetic Stresses - Stress Due to Operational Cover	Sheet	2	Of	2

GCL - Clay Soil Liner Interface

$$W = W_{\text{Geocomposite}} + W_{\text{Geomembrane}} + W_{\text{GCL}} \text{ from Self Weight} + \text{Operational Cover over length of slope}$$
$$321 \text{ lb/ft } W_{\text{Geocomposite}} + W_{\text{Geomembrane}} + W_{\text{GCL}} \text{ from Self Weight}$$
$$18,020 \text{ lb/ft Operational Cover over length of slope}$$

$$W = 18,341 \text{ lb/ft}$$

$$\text{GCL thickness, } t_{\text{GCL}} = 0.03 \text{ ft}$$

$$\delta_L = 29 \text{ degrees}$$

$$F_D = 5,800 \text{ lb/ft}$$

$$F_R = 9,645 \text{ lb/ft}$$

$$T_{\text{GCL}} = 0 \text{ lb/ft}$$

$$\sigma_{\text{Actual}} = 0 \text{ psi}$$

$$\sigma_{\text{Allowable}} = 133 \text{ psi}$$

FS = No Stress

HDR Computation

Job Number	453925-235691-018	No.
------------	-------------------	-----

Project	Charah Colon Mine	Computed	TMY	Date	10/2/2014
Subject	Permit Application	Checked	KP	Date	10/29/2014
Task	Geosynthetic Stresses - Stress Due to Structural Fill	Sheet	1	Of	2

Case 3: Stress due to Operational Cover and 10' Lift of Structural Fill

Ash Density, ρ_{ash} = 84 lb/ft³ (ash wet density based on 100% standard Proctor compaction, See Ref. 3)
 Ash Thickness, t_{ash} = 10 feet

$F_D = W \sin\beta$ Driving Force
 $F_R = W \cos\beta \tan\delta_L$ (frictional force)
 Tension = $F_D - F_R$ lb/ft 144 in²/ft²
 Stress = Tension/ $t/144$ psi 12 in/ft

Geocomposite - Geomembrane Interface

$W = W_{Geocomposite}$ from Self Weight + Operational Cover + 10' Ash over length of slope
 18,190 lb/ft $W_{Geocomposite}$ and $W_{Operational Cover}$
 90,315 lb/ft Ash over length of slope
 $W = 108,504$ lb/ft
 Geocomposite thickness, $t_{GT} = 0.03$ ft
 $\delta_L = 26$ degrees
 $F_D = 34,312$ lb/ft
 $F_R = 50,205$ lb/ft
 $T_{Geocomposite} = 0$ lb/ft
 $\sigma_{Actual} = 0$ psi
 $\sigma_{Allowable} = 294$ psi

FS = No Stress

Geomembrane - GCL Interface

$W = W_{Geocomposite} + W_{Geomembrane}$ from Self Weight + Operational Cover over length of slope
 18,221 lb/ft $W_{Operational Cover} + W_{Geocomposite} + W_{geomembrane}$
 90,315 lb/ft Ash over length of slope
 $W = 108,536$ lb/ft
 Geomembrane thickness, $t_{GM} = 0.01$ ft
 $\delta_L = 23$ degrees
 $F_D = 34,322$ lb/ft
 $F_R = 43,706$ lb/ft
 $T_{Geomembrane} = 0$ lb/ft
 $\sigma_{Actual} = 0$ psi
 $\sigma_{Allowable} = 2,100$ psi

FS = No Stress

HDR Computation

Job Number	453925-235691-018	No.
------------	-------------------	-----

Project	Charah Colon Mine	Computed	TMY	Date	10/2/2014
Subject	Permit Application	Checked	KP	Date	10/29/2014
Task	Geosynthetic Stresses - Stress Due to Structural Fill	Sheet	2	Of	2

GCL - Clay Soil Liner Interface

$$W = W_{\text{Geocomposite}} + W_{\text{Geomembrane}} + W_{\text{GCL}} \text{ from Self Weight} + \text{Operational Cover over length of slope}$$
$$18,341 \text{ lb/ft } W_{\text{Operational Cover}} + W_{\text{Geocomposite}} + W_{\text{Geomembrane}} + W_{\text{GCL}}$$
$$90,315 \text{ lb/ft Asg over length of slope}$$

$$W = 108,656 \text{ lb/ft}$$

$$\text{GCL thickness, } t_{\text{GCL}} = 0.03 \text{ ft}$$

$$\delta_L = 29 \text{ degrees}$$

$$F_D = 34,360 \text{ lb/ft}$$

$$F_R = 57,138 \text{ lb/ft}$$

$$T_{\text{GCL}} = 0 \text{ lb/ft}$$

$$\sigma_{\text{Actual}} = 0 \text{ psi}$$

$$\sigma_{\text{Allowable}} = 133 \text{ psi}$$

FS = No Stress

HDR Computation

Job Number	453925-235691-018	No.	
Project	Charah Colon Mine	Computed	TMY
Subject	Permit Application	Checked	KP
Task	Geosynthetic Stresses - Stress Due to Operational Equipment	Sheet	1
		Date	10/2/2014
		Date	10/29/2014
		Of	2

Case 4: Stress due to Operational Equipment

CAT D6R WH Waste Handler

Operating Wt. =	45,370	lb	(Assumed to be typical of equipment
Ground Contact Area =	4,564	in ²	placing operation cover with contact
Contact pressure =	9.9	psi	pressure less than 10 psi)

$$F_D = W \sin \beta \quad \text{Driving Force}$$

$$F_R = W \cos \beta \tan \delta_L \quad \text{(frictional force)} \quad 144 \text{ in}^2/\text{ft}^2$$

$$\text{Tension} = F_D - F_R \quad \text{lb/ft} \quad 12 \text{ in/ft}$$

$$\text{Stress} = \text{Tension}/t/144 \text{ psi}$$

Geocomposite - Geomembrane Interface

$$W = W_{\text{geocomposite}} + W_{\text{Operational Cover}} + W_{\text{Ash}} + W_{\text{Operational Equipment}}$$

$$108,504 \quad \text{lb/ft } W_{\text{Ash}} + W_{\text{Geocomposite}} + W_{\text{Operational Cover}}$$

$$1,431 \quad \text{lb/ft, } W_{\text{Operational Equipment}}$$

$$W = 109,936 \quad \text{lb/ft}$$

Geocomposite thickness, $t_{GT} = 0.03 \text{ ft}$

$$\delta_L = 26 \quad \text{degrees}$$

$$F_u = 34,765 \quad \text{lb}$$

$$F_L = 50,868 \quad \text{lb}$$

$$T_{\text{Geocomposite}} = 0 \quad \text{lb}$$

$$\sigma_{\text{Actual}} = 0 \quad \text{psi}$$

$$\sigma_{\text{Allowable}} = 294 \quad \text{psi}$$

FS = No Stress

Geomembrane - GCL Interface

$$W = W_{\text{Geomembrane}} + W_{\text{Geocomposite}} + W_{\text{Operational Cover}} + W_{\text{Ash}} + W_{\text{Operational Equipment}}$$

$$108,536 \quad \text{lb/ft } W_{\text{Ash}} + W_{\text{Operational Cover}} + W_{\text{Geocomposite}} + W_{\text{Geomembrane}}$$

$$1,431 \quad \text{lb/ft, } W_{\text{Operational Equipment}}$$

$$W = 109,967 \quad \text{lb/ft}$$

Geomembrane thickness, $t_{GM} = 0.01 \text{ ft}$

$$\delta_L = 23 \quad \text{degrees}$$

$$F_u = 34,775 \quad \text{lb}$$

$$F_L = 44,283 \quad \text{lb}$$

$$T_{\text{Geomembrane}} = 0 \quad \text{lb}$$

$$\sigma_{\text{Actual}} = 0 \quad \text{psi}$$

$$\sigma_{\text{Allowable}} = 2,100 \quad \text{psi}$$

FS = No Stress

HDR Computation

Job Number	453925-235691-018	No.	
Project	Charah Colon Mine	Computed	TMY
Subject	Permit Application	Checked	KP
Task	Geosynthetic Stresses - Stress Due to Operational Equipment	Sheet	2
		Date	10/2/2014
		Date	10/29/2014
		Of	2

GCL - Clay Soil Liner Interface

$$W = W_{GCL} + W_{Geomembrane} + W_{Geocomposite} + W_{Operational\ Cover} + W_{Ash} + W_{Operational\ Equipment}$$

$$108,656 \quad \text{lb/ft } W_{Ash} + W_{Operational\ Cover} + W_{Geocomposite} + W_{Geomembrane} + W_{GCL}$$

$$1,431 \quad \text{lb/ft, } W_{Operational\ Equipment}$$

$$W = 110,087 \quad \text{lb/ft}$$

GCL thickness, $t_{GCL} = 0.03 \quad \text{ft}$

$$\delta_L = 29 \quad \text{degrees}$$

$$F_u = 34,813 \quad \text{lb}$$

$$F_L = 57,891 \quad \text{lb}$$

$$T_{GCL} = 0 \quad \text{lb}$$

$$\sigma_{Actual} = 0 \quad \text{psi}$$

$$\sigma_{Allowable} = 133 \quad \text{psi}$$

FS = No Stress

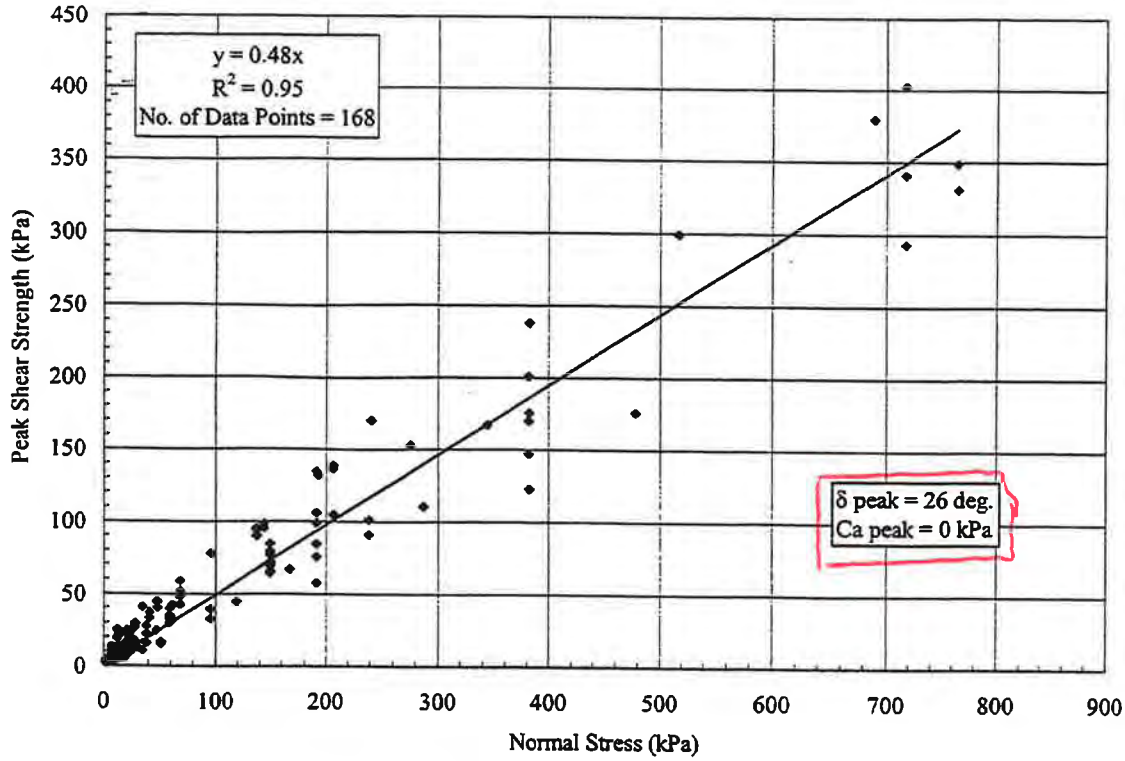

Appendix Figure 2i – Peak Shear Strength; Textured HDPE against NW-NP Geotextile on a Drainage Geocomposite.

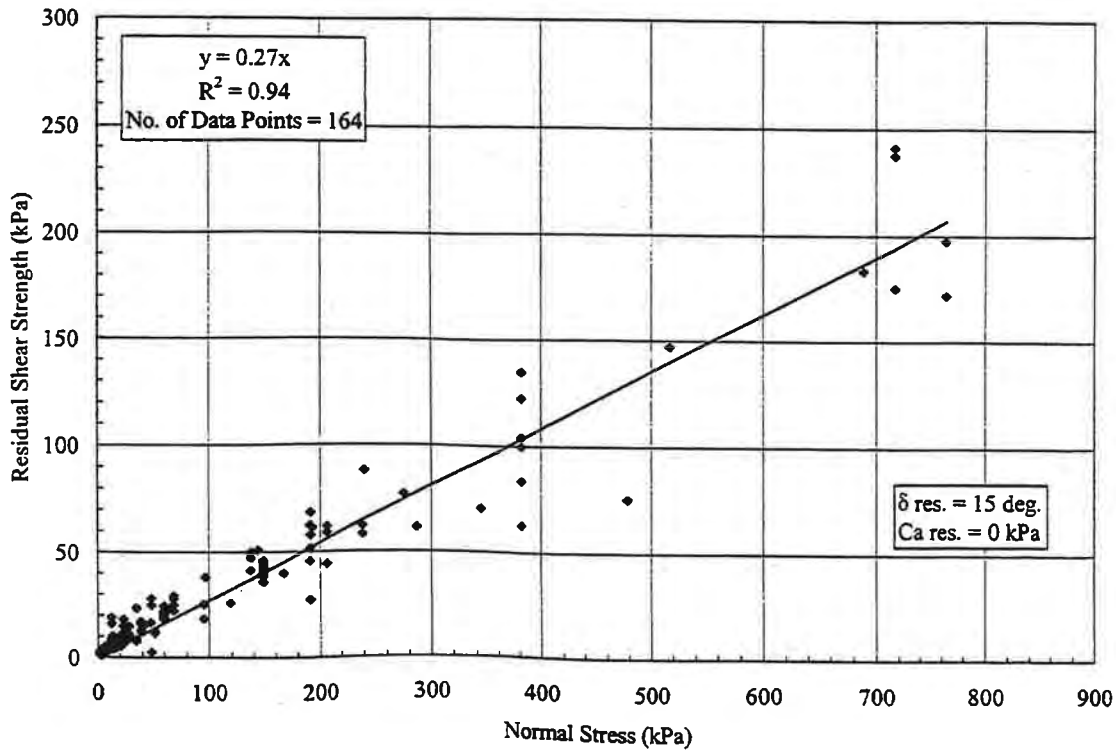

Appendix Figure 2j – Residual Shear Strength; Textured HDPE against NW-NP Geotextile on a Drainage Geocomposite.

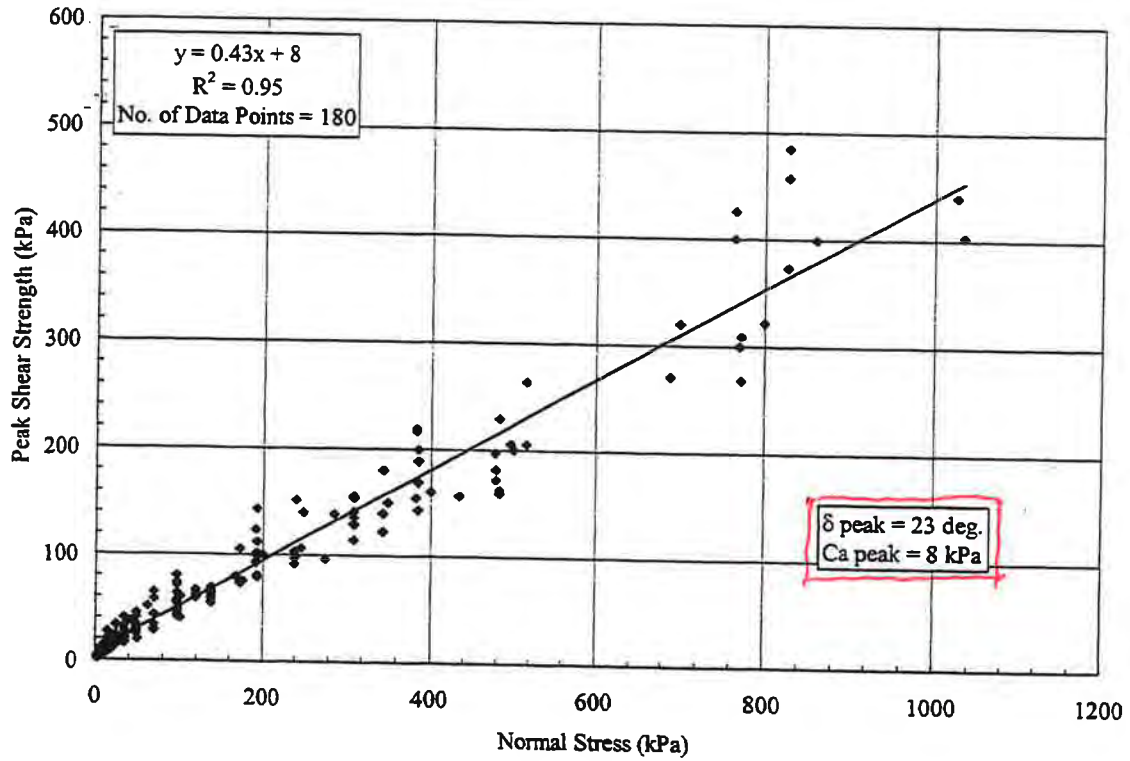

Appendix Figure 11a - Peak Shear Strength; Textured HDPE against NW-NP Side of Fabric-Reinforced GCL.

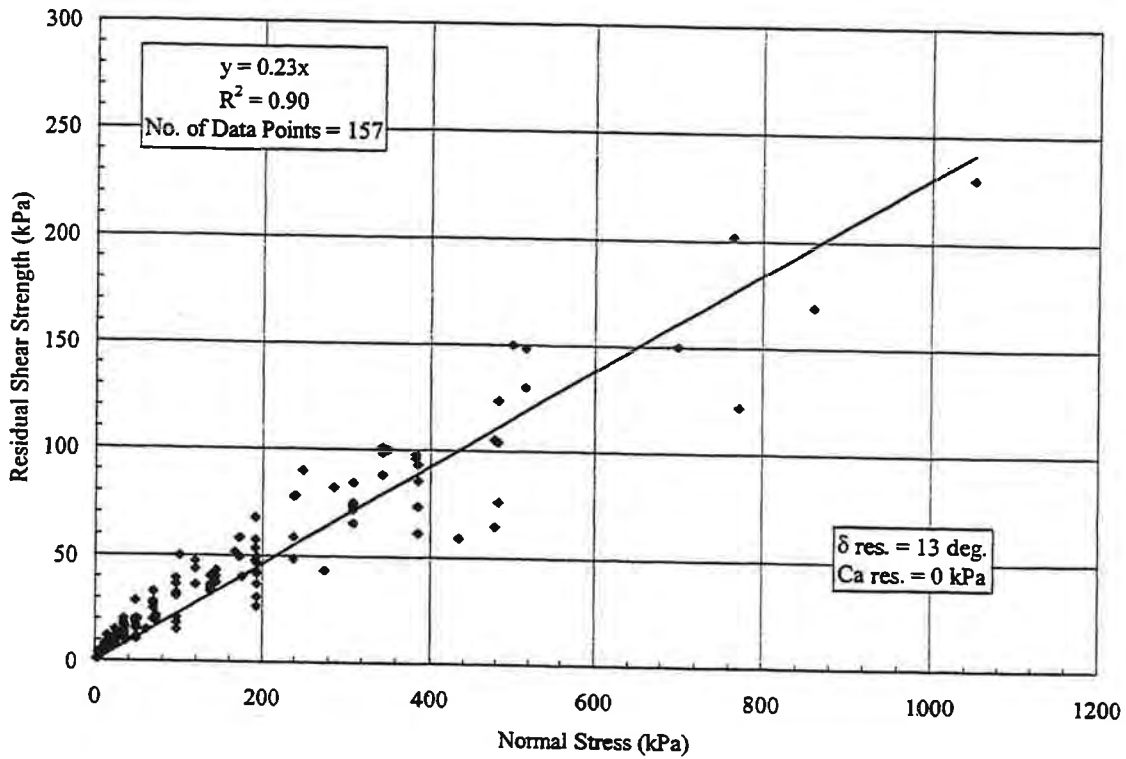

Appendix Figure 11b - Residual Shear Strength; Textured HDPE against NW-NP Side of Fabric-Reinforced GCL.

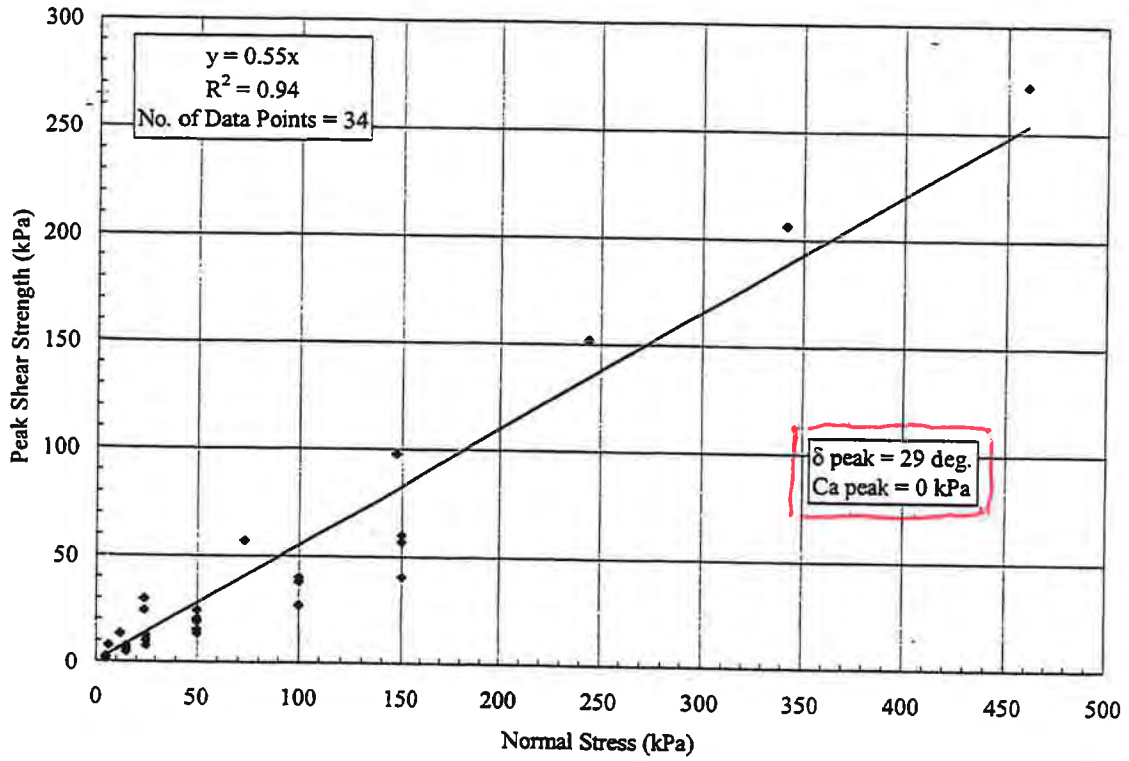

Appendix Figure 9e - Peak Shear Strength; Woven Geotextile against Cohesive Soil.

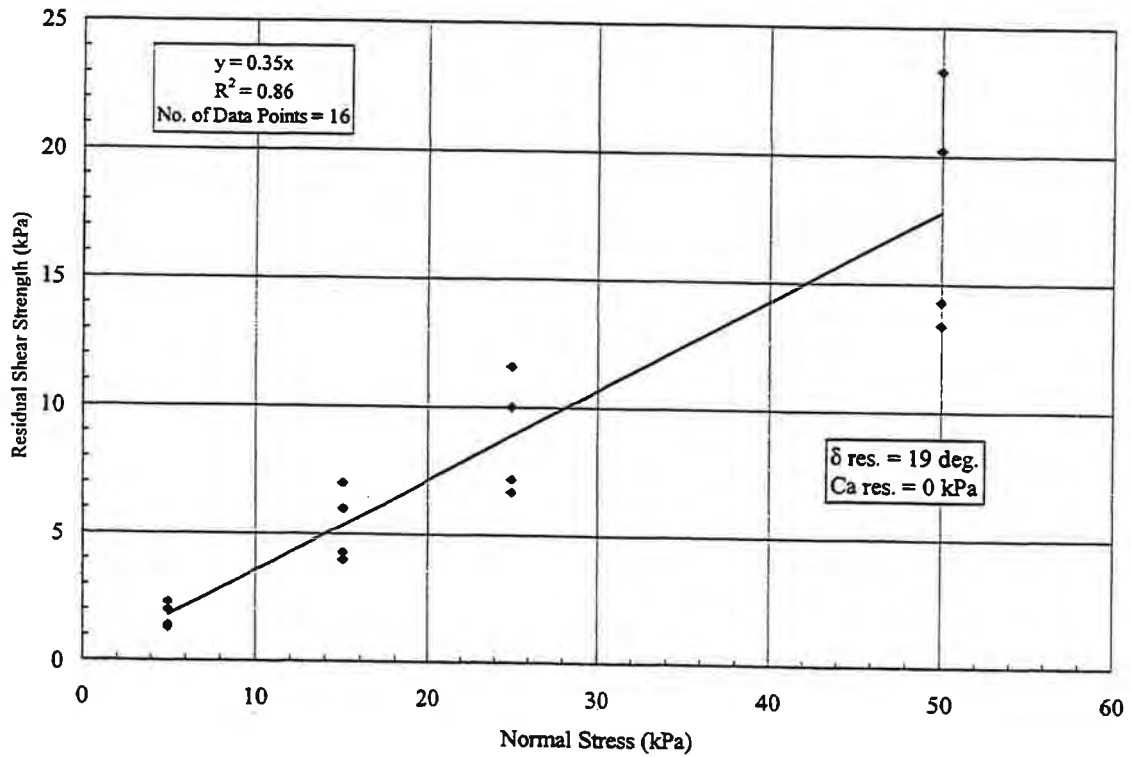

Appendix Figure 9f - Residual Shear Strength; Woven Geotextile against Cohesive Soil.

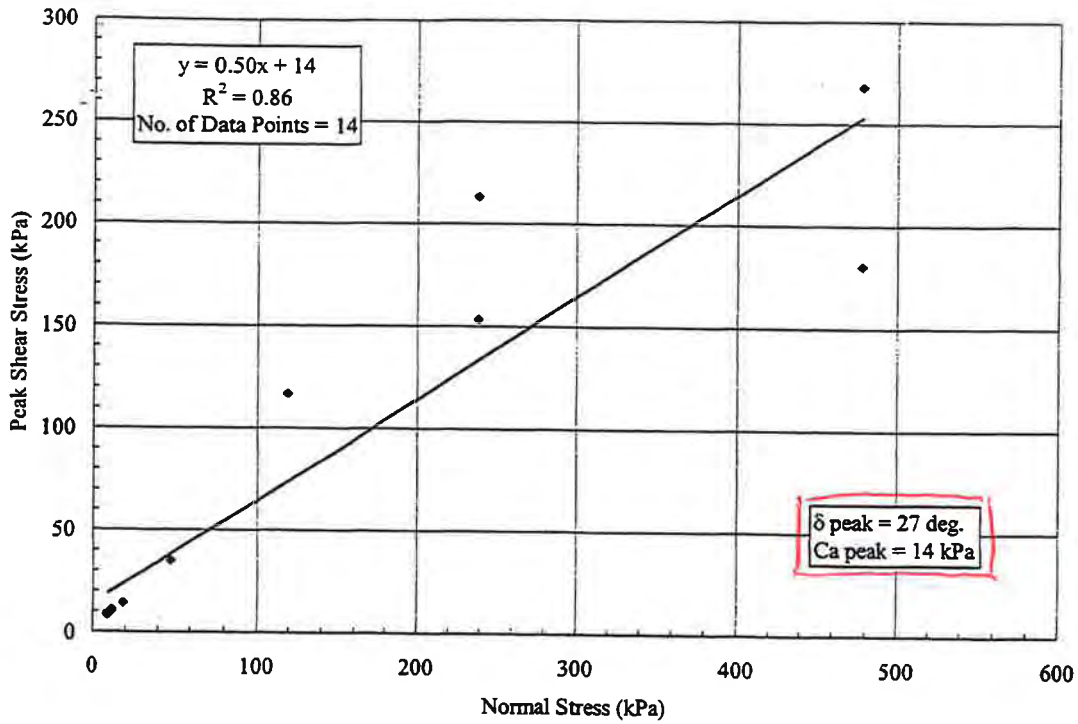

Appendix Figure 13a - Peak Shear Strength; Drainage Geocomposite against Granular Soil.

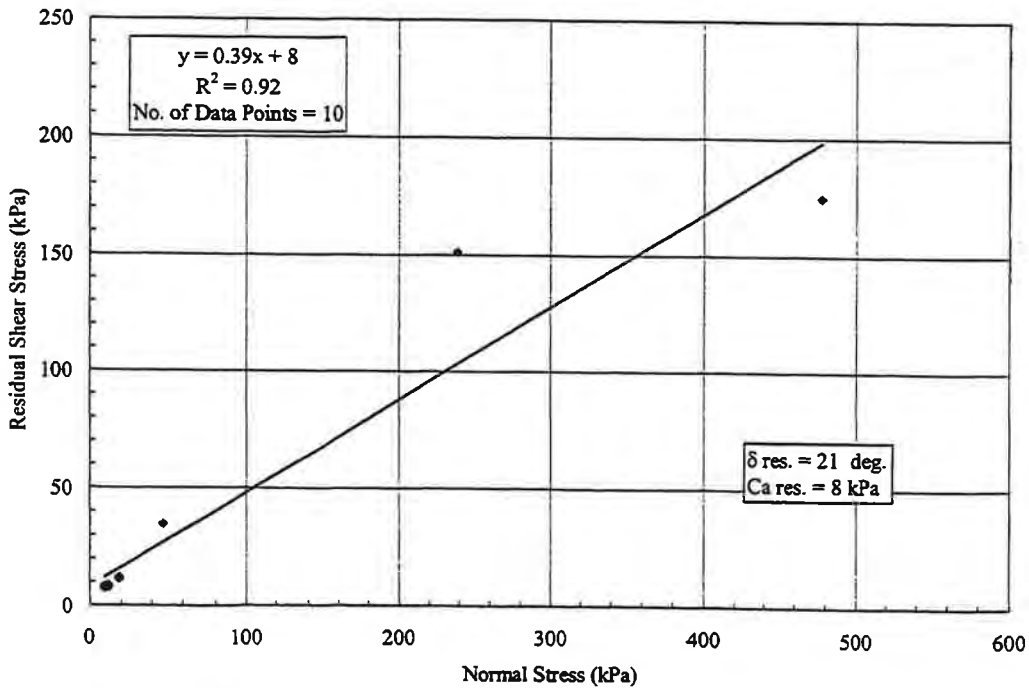

Appendix Figure 13b - Residual Shear Strength; Drainage Geocomposite against Granular Soil.

HDR Computation

Job Number 453925-235691-018

No.

Project Charah Colon Mine

Computed TMY

Date 10/2/2014

Subject Permit Application

Checked KP

Date 10/29/2014

Task Design Anchor Trench

Sheet 1

Of 3

Objective: Determine the maximum allowable anchor trench dimensions to allow geomembrane pullout before yield stress is exceeded. Evaluate cases for runout only and also anchor trench.

Reference:

1. Koerner, G.R. and D. Nareho. "Direct Shear Database of Geosynthetic-to-Geosynthetic and Geosynthetic-to-Soil Interfaces", GRI Report #30, June 2005
2. Koerner, Robert M., "Designing with Geosynthetics," Prentice Hall, Upper Saddle River, New Jersey, 4th edition, pp. 487-491.

Calculations: Without Trench (Runout only): Ref. 2

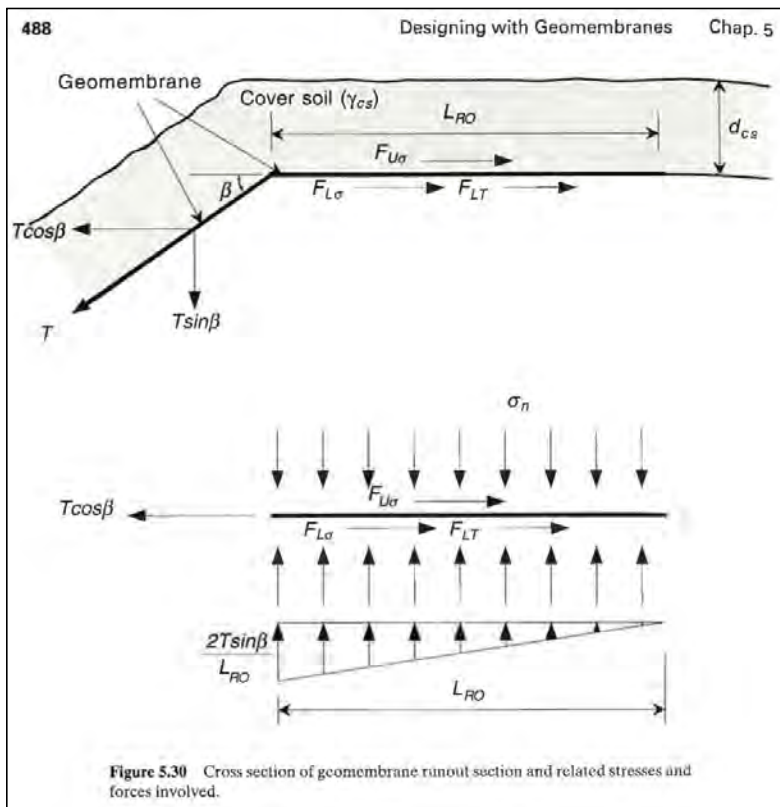

Figure 5.30 is from Reference 2

$$L_{RO} = \frac{T_{ALLOW}(\cos \beta - \sin \beta \tan \delta_L)}{\sigma_N(\tan \delta_U + \tan \delta_L)}$$

Where:

T_{ALLOW} = allowable force in geomembrane stress = $\sigma_{ALLOW}t$, where

σ_{ALLOW} = allowable stress in geomembrane, and t = thickness of geomembrane;

β = side slope angle;

σ_N = applied normal stress from cover soil;

δ_U = angle of shearing resistance between geomembrane and upper material; and

δ_L = angle of shearing resistance between geomembrane and underlying material; and

L_{RO} = length of geomembrane runout.

thickness of cover soil = 24 in (assumed Max.)
 unit weight of cover soil = 120 lb/ft³ (typical for silty clay)
 σ_N = 240 lb/ft²
 δ_U = 0.0 B/c the geocomposite/soil moves along with the geomembrane as it deforms
 δ_L = 23.0 See Attachment A (Ref. 1). Conservatively neglect cohesion at interface. Non-woven side of GCL against textured HDPE.

FS = 1.2 , desired FS
 σ_{ULT} = 126 lb/in (from specs - yield)
 σ_{ULT} = 2,211 psi
 σ_{ALLOW} = 1,842 psi
 t = 0.057 in
 T_{ALLOW} = 1,260 lb/ft
 β = 3 H:1V
 β = 18.43 degrees

$$L_{RO} = 10.1 \text{ ft}$$

This represents largest runout w/o anchor trench.

With Runout Length & Trench: Ref. 2

HDR Computation

Job Number 453925-235691-018

No.

Project Charah Colon Mine

Computed TMY

Date 10/2/2014

Subject Permit Application

Checked KP

Date 10/29/2014

Task Design Anchor Trench

Sheet 2

Of 3

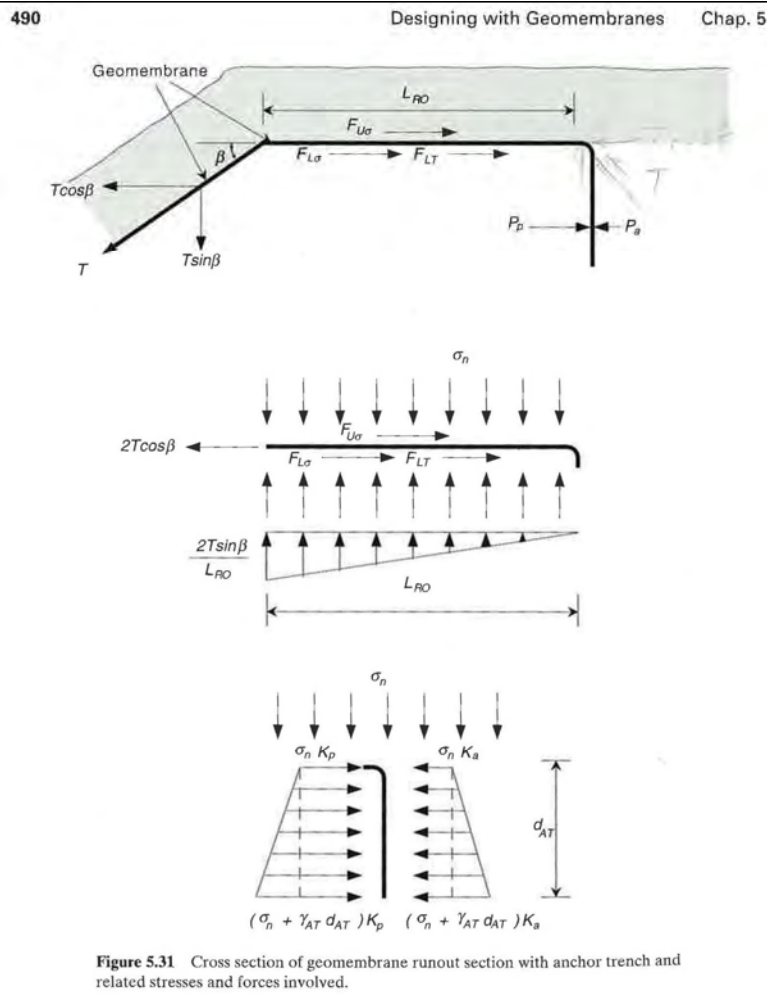

Where:

T_{ALLOW} = allowable force in geomembrane stress = $\sigma_{ALLOW}t$, where

σ_{ALLOW} = allowable stress in geomembrane, and
 t = thickness of geomembrane;

β = side slope angle;

$F_{U\sigma}$ = shear force above geomembrane due to cover soil

$F_{L\sigma}$ = shear force below geomembrane due to cover soil

F_{LT} = shear force below geomembrane due to vertical component of T_{ALLOW}

P_A = active earth pressure against the backfill side of the anchor trench

P_P = passive earth pressure against the in-situ side of the anchor trench

γ_{AT} = unit weight of soil in anchor trench

d_{AT} = depth of anchor trench

σ_N = applied normal stress from cover soil;

K_A = coefficient of active earth pressure = $\tan^2(45-\phi/2)$

K_P = coefficient of passive earth pressure = $\tan^2(45+\phi/2)$

ϕ = angle of shearing resistance of respective soil

$$T_{ALLOW} \cos \beta = F_{U\sigma} + F_{L\sigma} + F_{LT} - P_A + P_P$$

$$P_A = (0.5\gamma_{AT}d_{AT} + \sigma_N)K_A d_{AT}$$

$$P_P = (0.5\gamma_{AT}d_{AT} + \sigma_N)K_P d_{AT}$$

$$F_{U\sigma} = \sigma_N \tan \delta_U (L_{RO})$$

$$= 0.0 \quad L_{RO}$$

$$F_{L\sigma} = \sigma_N \tan \delta_L (L_{RO})$$

$$= 101.9 \quad L_{RO}$$

$$F_{LT} = T_{ALLOW} \sin \beta \tan \delta_L$$

$$= 169.1 \quad \text{lb/ft}$$

$$\gamma_{AT} = 120 \quad \text{lb/ft}^3$$

$$\sigma_N = 240 \quad \text{lb/ft}^2$$

$$\phi = 30 \quad ^\circ, \text{ assumed}$$

$$K_A = 0.3333$$

$$K_P = 3.0000$$

HDR Computation

Job Number 453925-235691-018

No.

Project Charah Colon Mine

Computed TMY

Date 10/2/2014

Subject Permit Application

Checked KP

Date 10/29/2014

Task Design Anchor Trench

Sheet 3

Of 3

$$\text{TRY } L_{RO} = 2 \text{ ft}$$

$$P_A = (80.4 d_{AT} + 240) \times (K_A \times d_{AT})$$

$$P_P = (80.4 d_{AT} + 240) \times (K_P \times d_{AT})$$

$$T_{ALLOWCOS \beta} = F_{U\sigma} + F_{L\sigma} + F_{LT} - P_A + P_P$$

$$T_{ALLOWCOS \beta} = F_{U\sigma} + F_{L\sigma} + F_{LT} - (80.4 d_{AT} + 240) \times (K_A \times d_{AT}) + (80.4 d_{AT} + 240) \times (K_P \times d_{AT})$$

$$1,195 = F_{U\sigma} + F_{L\sigma} + F_{LT} - 26.8 d_{AT}^2 - 80 d_{AT} + 241.2 d_{AT}^2 + 720 d_{AT}$$

$$1,195 = 372.9 - 214.4 d_{AT}^2 + 640 d_{AT}$$

$$0 = -822.5 - 214.4 d_{AT}^2 + 640 d_{AT}$$

$$0 = 0 \quad \text{When } d_{AT} = 0.970 \text{ ft} \quad (\text{adjust } d_{AT} \text{ until right side of equation} = 0)$$

$d_{AT} = 1.0 \text{ ft}$
$L_{RO} = 2 \text{ ft}$

Use $d_{AT} = 1.0 \text{ ft}$ and $L_{RO} = 2.0 \text{ ft}$. Since calcs are based on yield stress, extra FS is included.

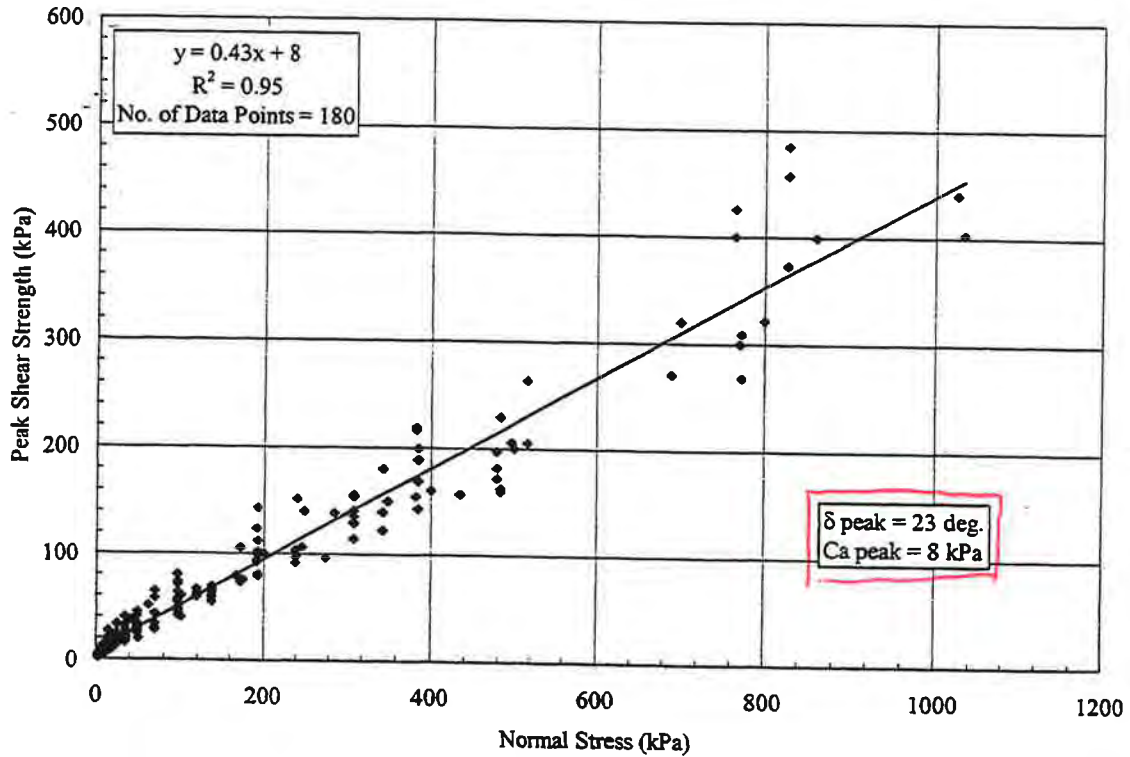

Appendix Figure 11a - Peak Shear Strength; Textured HDPE against NW-NP Side of Fabric-Reinforced GCL.

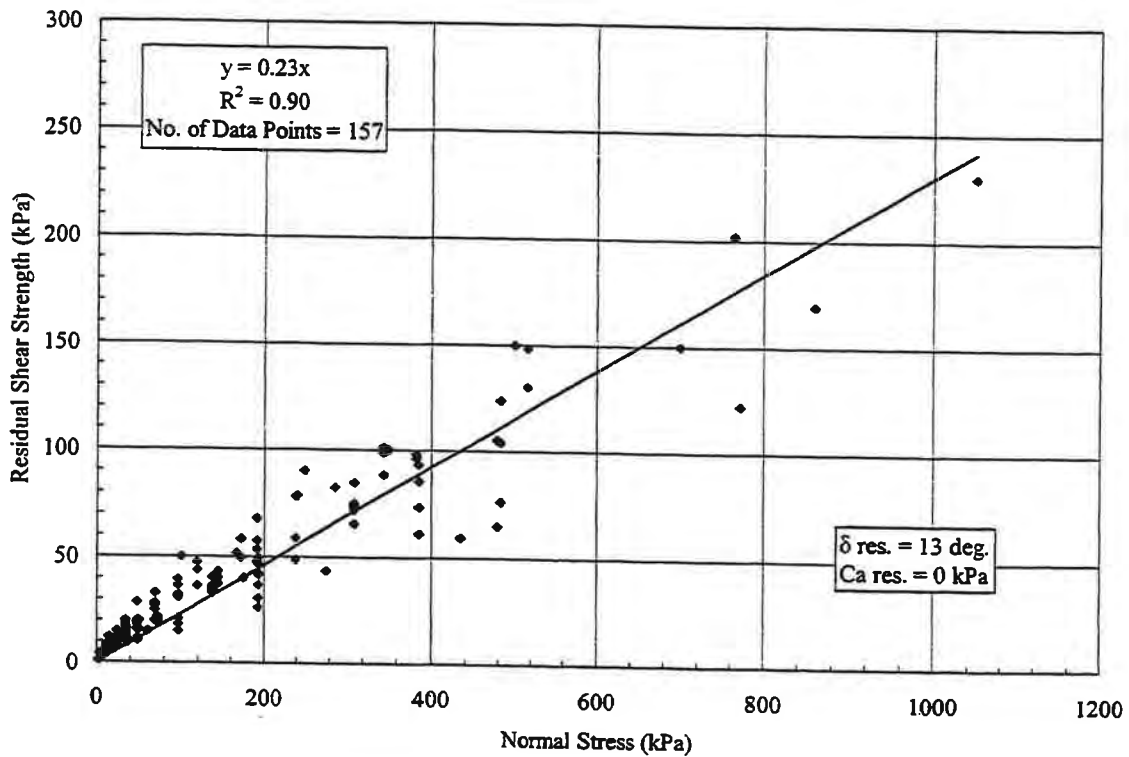

Appendix Figure 11b - Residual Shear Strength; Textured HDPE against NW-NP Side of Fabric-Reinforced GCL.

D

Leachate Collection System

Design of Leachate Collection System
Pipe Sizing
Pipe Stresses
Pipe Orifice Sizing
Pipe Perforations
Pipe Capacity
Leachate Tank Sizing



This page intentionally left blank.

Memo

Date: Sunday, March 08, 2015

Project: Charah Colon Mine

To: Michael Plummer

From: Eric Wright

Subject: HELP Model - Slope and Pipe Spacing vs Peak Head on Liner

The HELP model was run for some initial lift conditions where no runoff was allowed. Most of the runs include a 25-year 24-hour storm event of 6.28 inches. The initial runs were done with the default data which had a 5.22 inch storm event. The runs adjusted drainage length for a group of slopes to maintain less than 30 cm (11.8 inches) of peak head on the liner system.

The table below summarizes the results. The HELP model runs are provided in Attachment 2 to the Design of the Leachate Collection System narrative. These seven scenarios replace all HELP model runs previously provided in Attachments 2 and 6 (Attachment 6 has been deleted).

Scenario	HELP Model	Max Storm (in)	Ash Thickness (ft)	Lift Thickness (ft)	Floor Slope	Drainage Length (ft)	Peak Head (in)
1	5-2ft lifts no runoff 0.5%	6.28	10	2	0.5%	300	9.7
2	5-2ft lifts no runoff 1%	6.28	10	2	1%	425	11.6
3	5-2ft lifts no runoff 2%	6.28	10	2	2%	600	11.6
4	5-2ft lifts no runoff 3%	6.28	10	2	3%	840	9.5
5	10-2ft lifts no runoff 2%	6.28	20	2	2%	950	0.36
6	2-20ft lifts no runoff 2%	6.28	20	20	2%	950	0.32
7	3-20ft lifts no runoff 2%	6.28	20	20	2%	950	0.26

This page intentionally left blank.

Computed: MDP	Date: 3/8/15
Checked : PAW	Date: 3/8/15

Design of Leachate Collection System

The HELP model Version 3.95D is used to design the leachate collection system for the Colon Mine Site in Sanford, NC. This section presents the design assumptions, decisions, background data, and calculations for the water balance model. The section outlines efforts to establish leachate generation rates and maximum hydraulic heads on the liner. The leachate generation rates established per acre should be used to design the leachate collection and removal system.

The structural fill liner will consist of the following components, from bottom to top.

- 18-inch compacted soil liner
- GCL
- 60-mil HDPE primary liner
- 300-mil biplanar drainage geocomposite

HELP Model Scenarios and Input Data

- Scenario 1 modeled a 10-foot depth of ash placed in five 2-foot lifts on the floor of the 0.5% liner based on a 5-year simulation period.
- Scenario 2 modeled a 10-foot depth of ash placed in five 2-foot lifts on the floor of the 1.0% liner based on a 5-year simulation period.
- Scenario 3 modeled a 10-foot depth of ash placed in five 2-foot lifts on the floor of the 2.0% liner based on a 5-year simulation period.
- Scenario 4 modeled a 10-foot depth of ash placed in five 2-foot lifts on the floor of the 3.0% liner based on a 5-year simulation period.
- Scenario 5 modeled ten 2-foot lifts based on the 2% floor of the liner on a 5-year simulation period.
- Scenario 6 modeled two 20-foot lifts based on the 2% floor of the liner on a 5-year simulation period.
- Scenario 7 modeled three 20-foot lifts based on 5-year simulation period.

Each scenario was modeled as a 1-acre area. A major goal for the modeling was to demonstrate that the drainage layer capacity is not exceeded. The second aim of the modeling was to estimate leachate production. The table in Attachment 1 provided summarizes the model input data, and summarizes the results of the scenarios. HELP model output files for scenarios 1-7 are provided in Attachment 2.

Temperature and solar radiation data were synthetically generated using coefficients from Raleigh, NC. Evapotranspiration data from Raleigh, NC was used in all scenarios. Sanford is located approximately 35 miles southeast of Raleigh, NC and should be accurately represented by weather data generated from Raleigh. Precipitation data was revised to capture the 25-year, 24-hour storm event with a rainfall of 6.28 inches in one day.

Computed: MDP	Date: 3/8/15
Checked : PAW	Date: 3/8/15

Material Properties and Structural Fill Geometry

The maximum flow path for leachate in the leachate drainage layer geocomposite will vary between 300 and 950 feet depending on the slope of the floor, at which point the leachate will enter an interceptor perforated pipe surrounded by gravel trench for conveyance to the sumps.

Material Properties

Initial moisture content for ash after placement at the cell is set at optimum moisture content based on proctor test data for open-fill runs. The initial moisture content for ash is set to the field capacity of coal burning electric plant fly ash for the closed-fill runs. Refer to Attachment 4 for physical properties of material.

- Default model parameters were used for the final cover layers and subgrade. Note the permeability for final cover layers was manually adjusted.
- Structural fill base liner was modeled as material texture 35, HDPE.
- Structural fill final cover liner was modeled as material texture 36, LLDPE
- Pinhole density for the membrane liners was set at 1 per acre.
- Installation defects were set at 1 per acre for the membrane liners, reflective of generally good installation procedures.
- Membrane liner placement quality was assumed to be “good”.
- Structural fill base leachate drainage layer was modeled as material texture 34, except the transmissivity was modified to reflect select material properties (Refer to Attachment 3). Transmissivity of the geocomposite should be determined based on site-specific ash and loading before selecting the material for installation.

A detailed calculation of the bottom liner geocomposite’s required hydraulic conductivity is contained in Attachment 3. The maximum overburden pressure, based on 100 pcf density and approximately 50 foot ash/soil mixture is 5000 psf.

Model Outputs and Conclusions

The table in Attachment 1 summarizes the model outputs for each of the scenarios considered. The model demonstrates that the proposed design will comply with applicable design standards. More specifically:

- The peak head on HDPE bottom liner in any HELP Model scenario is 11.6 inches.
- Maximum leachate generated during filling is 1,822 cf/acre/day at a 3% floor slope.
- Drainage length in the bottom ranges from 300 - 950 feet depending on the floor slopes.
- As ash is placed the required drainage length to maintain head on the liner system increases.

Attachment 1 (revised)

Summary of Model Input Data and Results

This page intentionally left blank.

Attachment 1
HELP Model Results
Charah Colon Mine

Input Data

Parameter	Scenario 1	Scenario 2	Scenario 3	Scenario 4	Scenario 5	Scenario 6	Scenario 7
SCS runoff curve number	91.21	91.21	91.21	91.21	91.21	91.21	91.21
fraction of area allowing runoff (%)	0	0	0	0	0	0	0
area simulated (acres)	1	1	1	1	1	1	1
Ash k (cm/sec)	1.6x10 ⁻⁴	1.6x10 ⁻⁴	1.6x10 ⁻⁴	1.6x10 ⁻⁴	1.6x10 ⁻⁴	1.6x10 ⁻⁴	1.6x10 ⁻⁴
Ash Thickness (ft)	10	10	10	10	20	40	60
subgrade thickness (inches)	18	18	18	18	18	18	18
geocomposite thickness (inches)	0.26	0.26	0.26	0.26	0.26	0.26	0.26
geocomposite hydr. conductivity (cm/sec)	9.7	9.7	9.7	9.7	9.7	9.7	9.7
bottom liner drainage layer slope (%)	0.5	1	2	3	2	2	2
bottom liner drainage length (feet)	300	425	600	840	950	950	950
HDPE liner thickness (mils)	60	60	60	60	60	60	60
liner pinhole density (holes/acre)	1	1	1	1	1	1	1
liner installation defects (holes/acre)	1	1	1	1	1	1	1
liner placement quality	good	good	good	good	good	good	good
recirculation? (amount recirculated)	N	N	N	N	N	N	N
cap drainage layer thickness (inches)	N/A	N/A	N/A	N/A	N/A	N/A	N/A
cap drainage layer k (cm/sec)	N/A	N/A	N/A	N/A	N/A	N/A	N/A
cap liner thickness (mils)	N/A	N/A	N/A	N/A	N/A	N/A	N/A
cap liner pinhole density (holes/acre)	N/A	N/A	N/A	N/A	N/A	N/A	N/A
cap liner installation defects (holes/acre)	N/A	N/A	N/A	N/A	N/A	N/A	N/A
cap liner placement quality	N/A	N/A	N/A	N/A	N/A	N/A	N/A
number of years simulated	5	5	5	5	5	5	5

Output Data

average annual leachate collected in base liner system collection layer (ft ³)	55,042	55,044	55,046	55,046	59,786	69,300	78,144
average annual head on primary base liner (inches)	0.18	0.10	0.04	0.02	0.04	0.05	0.05
peak day leachate collected in base liner system collection layer (ft ³)	984	1203	1703	1822	756	674	548
peak day max head on primary base liner (inches)	11.53	11.58	11.64	9.50	0.36	0.32	0.26

This page intentionally left blank.

Attachment 2 (replaced)

HELP Model Output Files (Scenarios 1-7)

This page intentionally left blank.

```

*****
*****
**
**
**          HYDROLOGIC EVALUATION OF LANDFILL PERFORMANCE          **
**
**          HELP Version 3.95 D          (10 August 2012)          **
**                    developed at          **
** Institute of Soil Science, University of Hamburg, Germany      **
**                    based on          **
**          US HELP MODEL VERSION 3.07 (1 NOVEMBER 1997)          **
**                    DEVELOPED BY ENVIRONMENTAL LABORATORY        **
**                    USAE WATERWAYS EXPERIMENT STATION           **
**          FOR USEPA RISK REDUCTION ENGINEERING LABORATORY        **
**
**
*****
*****

```

TIME: 10.27 DATE: 8.03.2015

```

PRECIPITATION DATA FILE:      C:\Users\mplummer\Desktop\HELP runs\Weather Data\SF
Charah Sanford 25 yr storm y3m8d16.d4
TEMPERATURE DATA FILE:       C:\Users\mplummer\Desktop\HELP runs\Weather
Data\Charah Sanford.d7
SOLAR RADIATION DATA FILE:   C:\Users\mplummer\Desktop\HELP runs\Weather
Data\Charah Sanford.d13
EVAPOTRANSPIRATION DATA F. 1: C:\Users\mplummer\Desktop\HELP runs\Weather
Data\Charah Sanford.d11
SOIL AND DESIGN DATA FILE 1: C:\Users\mplummer\Desktop\HELP runs\Mike's
runs\MPColon 5-2ft lifts no runoff 05% 300.d10
OUTPUT DATA FILE:           C:\Users\mplummer\Desktop\HELP runs\0.5% MPRevised.out

```

```

*****
TITLE: Coal Ash-First Lift (Five Lifts, No Runoff, 0.5% slope)
*****

```

WEATHER DATA SOURCES

NOTE: PRECIPITATION DATA FOR RALEIGH NORTH CAROLINA
 WAS ENTERED BY THE USER.

NOTE: TEMPERATURE DATA WAS SYNTHETICALLY GENERATED USING
 COEFFICIENTS FOR RALEIGH NORTH CAROLINA

NORMAL MEAN MONTHLY TEMPERATURE (DEGREES FAHRENHEIT)

JAN/JUL FEB/AUG MAR/SEP APR/OCT MAY/NOV JUN/DEC

39.60	41.60	49.30	59.50	67.20	73.90
77.70	77.00	71.00	59.70	50.00	42.00

NOTE: SOLAR RADIATION DATA WAS SYNTHETICALLY GENERATED USING
 COEFFICIENTS FOR RALEIGH NORTH CAROLINA
 AND STATION LATITUDE = 35.87 DEGREES

LAYER DATA 1

VALID FOR 5 YEARS

NOTE: INITIAL MOISTURE CONTENT OF THE LAYERS AND SNOW WATER
 WERE SPECIFIED BY THE USER.

LAYER 1

TYPE 1 - VERTICAL PERCOLATION LAYER

MATERIAL TEXTURE NUMBER 0

THICKNESS = 24.00 INCHES
 POROSITY = 0.5410 VOL/VOL
 FIELD CAPACITY = 0.1870 VOL/VOL
 WILTING POINT = 0.0470 VOL/VOL
 INITIAL SOIL WATER CONTENT = 0.3100 VOL/VOL
 EFFECTIVE SAT. HYD. CONDUCT.= 0.1600E-03 CM/SEC

LAYER 2

TYPE 1 - VERTICAL PERCOLATION LAYER

MATERIAL TEXTURE NUMBER 0

THICKNESS = 24.00 INCHES
 POROSITY = 0.5410 VOL/VOL
 FIELD CAPACITY = 0.1870 VOL/VOL
 WILTING POINT = 0.0470 VOL/VOL
 INITIAL SOIL WATER CONTENT = 0.3100 VOL/VOL
 EFFECTIVE SAT. HYD. CONDUCT.= 0.1600E-03 CM/SEC

LAYER 3

TYPE 1 - VERTICAL PERCOLATION LAYER

MATERIAL TEXTURE NUMBER 0

THICKNESS = 24.00 INCHES
 POROSITY = 0.5410 VOL/VOL

FIELD CAPACITY = 0.1870 VOL/VOL
 WILTING POINT = 0.0470 VOL/VOL
 INITIAL SOIL WATER CONTENT = 0.3100 VOL/VOL
 EFFECTIVE SAT. HYD. CONDUCT.= 0.1600E-03 CM/SEC

LAYER 4

TYPE 1 - VERTICAL PERCOLATION LAYER

MATERIAL TEXTURE NUMBER 0

THICKNESS = 24.00 INCHES
 POROSITY = 0.5410 VOL/VOL
 FIELD CAPACITY = 0.1870 VOL/VOL
 WILTING POINT = 0.0470 VOL/VOL
 INITIAL SOIL WATER CONTENT = 0.3100 VOL/VOL
 EFFECTIVE SAT. HYD. CONDUCT.= 0.1600E-03 CM/SEC

LAYER 5

TYPE 1 - VERTICAL PERCOLATION LAYER

MATERIAL TEXTURE NUMBER 0

THICKNESS = 24.00 INCHES
 POROSITY = 0.5410 VOL/VOL
 FIELD CAPACITY = 0.1870 VOL/VOL
 WILTING POINT = 0.0470 VOL/VOL
 INITIAL SOIL WATER CONTENT = 0.3100 VOL/VOL
 EFFECTIVE SAT. HYD. CONDUCT.= 0.1600E-03 CM/SEC

LAYER 6

TYPE 2 - LATERAL DRAINAGE LAYER

MATERIAL TEXTURE NUMBER 0

THICKNESS = 0.26 INCHES
 POROSITY = 0.8500 VOL/VOL
 FIELD CAPACITY = 0.0100 VOL/VOL
 WILTING POINT = 0.0050 VOL/VOL
 INITIAL SOIL WATER CONTENT = 0.0100 VOL/VOL
 EFFECTIVE SAT. HYD. CONDUCT.= 9.700 CM/SEC
 SLOPE = 0.50 PERCENT
 DRAINAGE LENGTH = 300.0 FEET

LAYER 7

TYPE 4 - FLEXIBLE MEMBRANE LINER

MATERIAL TEXTURE NUMBER 35

THICKNESS = 0.06 INCHES
 EFFECTIVE SAT. HYD. CONDUCT.= 0.2000E-12 CM/SEC
 FML PINHOLE DENSITY = 1.00 HOLES/ACRE
 FML INSTALLATION DEFECTS = 1.00 HOLES/ACRE

FML PLACEMENT QUALITY = 3 - GOOD

LAYER 8

TYPE 3 - BARRIER SOIL LINER

MATERIAL TEXTURE NUMBER 17

THICKNESS = 0.25 INCHES
 POROSITY = 0.7500 VOL/VOL
 FIELD CAPACITY = 0.7470 VOL/VOL
 WILTING POINT = 0.4000 VOL/VOL
 INITIAL SOIL WATER CONTENT = 0.7500 VOL/VOL
 EFFECTIVE SAT. HYD. CONDUCT.= 0.3000E-08 CM/SEC

LAYER 9

TYPE 1 - VERTICAL PERCOLATION LAYER

MATERIAL TEXTURE NUMBER 16

THICKNESS = 18.00 INCHES
 POROSITY = 0.4270 VOL/VOL
 FIELD CAPACITY = 0.4180 VOL/VOL
 WILTING POINT = 0.3670 VOL/VOL
 INITIAL SOIL WATER CONTENT = 0.4180 VOL/VOL
 EFFECTIVE SAT. HYD. CONDUCT.= 0.1000E-06 CM/SEC

GENERAL DESIGN AND EVAPORATIVE ZONE DATA 1

VALID FOR 5 YEARS

NOTE: SCS RUNOFF CURVE NUMBER WAS COMPUTED FROM DEFAULT SOIL DATA BASE USING SOIL TEXTURE # 9 WITH BARE GROUND CONDITIONS, A SURFACE SLOPE OF 2.% AND A SLOPE LENGTH OF 1000. FEET.

SCS RUNOFF CURVE NUMBER = 91.21
 FRACTION OF AREA ALLOWING RUNOFF = 0.0 PERCENT
 AREA PROJECTED ON HORIZONTAL PLANE = 1.000 ACRES
 EVAPORATIVE ZONE DEPTH = 18.0 INCHES
 INITIAL WATER IN EVAPORATIVE ZONE = 5.580 INCHES
 UPPER LIMIT OF EVAPORATIVE STORAGE = 9.738 INCHES
 FIELD CAPACITY OF EVAPORATIVE ZONE = 3.366 INCHES
 LOWER LIMIT OF EVAPORATIVE STORAGE = 0.846 INCHES
 SOIL EVAPORATION ZONE DEPTH = 18.000 INCHES
 INITIAL SNOW WATER = 0.000 INCHES
 INITIAL INTERCEPTION WATER = 0.000 INCHES
 INITIAL WATER IN LAYER MATERIALS = 44.914 INCHES
 TOTAL INITIAL WATER = 44.914 INCHES
 TOTAL SUBSURFACE INFLOW = 0.00 INCHES/YEAR

EVAPOTRANSPIRATION DATA 1

VALID FOR 5 YEARS

NOTE: EVAPOTRANSPIRATION DATA WAS OBTAINED FROM
RALEIGH NORTH CAROLINA

STATION LATITUDE = 35.87 DEGREES
 MAXIMUM LEAF AREA INDEX = 4.50
 START OF GROWING SEASON (JULIAN DATE) = 86
 END OF GROWING SEASON (JULIAN DATE) = 310
 EVAPORATIVE ZONE DEPTH = 18.0 INCHES
 AVERAGE ANNUAL WIND SPEED = 7.70 MPH
 AVERAGE 1ST QUARTER RELATIVE HUMIDITY = 66.0 %
 AVERAGE 2ND QUARTER RELATIVE HUMIDITY = 70.0 %
 AVERAGE 3RD QUARTER RELATIVE HUMIDITY = 78.0 %
 AVERAGE 4TH QUARTER RELATIVE HUMIDITY = 72.0 %

FINAL WATER STORAGE AT END OF YEAR 5

LAYER	(INCHES)	(VOL/VOL)
----	-----	-----
1	7.0193	0.2925
2	6.3803	0.2658
3	4.8629	0.2026
4	5.4737	0.2281
5	5.6427	0.2351
6	0.0134	0.0522
7	0.0000	0.0000
8	0.1875	0.7500
9	7.5240	0.4180
TOTAL WATER IN LAYERS	37.104	
SNOW WATER	0.000	
INTERCEPTION WATER	0.000	
TOTAL FINAL WATER	37.104	

PEAK DAILY VALUES FOR YEARS	1 THROUGH	5
	(INCHES)	(CU. FT.)
PRECIPITATION	6.28	22796.400
RUNOFF	0.000	0.0000
DRAINAGE COLLECTED FROM LAYER 6	0.27121	984.47894
PERCOLATION/LEAKAGE THROUGH LAYER 8	0.000003	0.01162
AVERAGE HEAD ON TOP OF LAYER 7	9.696	
MAXIMUM HEAD ON TOP OF LAYER 7	11.534	
LOCATION OF MAXIMUM HEAD IN LAYER 6 (DISTANCE FROM DRAIN)	145.5 FEET	
PERCOLATION/LEAKAGE THROUGH LAYER 9	0.000003	0.01162
SNOW WATER	1.67	6061.1177
MAXIMUM VEG. SOIL WATER (VOL/VOL)		0.5112
MINIMUM VEG. SOIL WATER (VOL/VOL)		0.0470

*** Maximum heads are computed using McEnroe's equations. ***

Reference: Maximum Saturated Depth over Landfill Liner
by Bruce M. McEnroe, University of Kansas
ASCE Journal of Environmental Engineering
Vol. 119, No. 2, March 1993, pp. 262-270.

AVERAGE MONTHLY VALUES IN INCHES FOR YEARS	1 THROUGH	5				
	JAN/JUL	FEB/AUG	MAR/SEP	APR/OCT	MAY/NOV	JUN/DEC
PRECIPITATION						
TOTALS	3.26	2.82	4.37	2.63	3.53	5.42
	4.57	6.47	2.81	3.77	2.52	2.90

Scenario 1 - Five 2-foot Lifts; No Runoff; 0.5% Slope

STD. DEVIATIONS	2.96	0.95	1.30	1.89	2.64	1.99
	2.29	6.38	1.69	2.69	1.66	1.28
RUNOFF						

TOTALS	0.000	0.000	0.000	0.000	0.000	0.000
	0.000	0.000	0.000	0.000	0.000	0.000
STD. DEVIATIONS	0.000	0.000	0.000	0.000	0.000	0.000
	0.000	0.000	0.000	0.000	0.000	0.000
POTENTIAL EVAPOTRANSPIRATION						

TOTALS	1.892	2.205	3.293	4.787	6.327	6.770
	7.049	5.890	4.466	3.365	2.345	1.543
STD. DEVIATIONS	0.140	0.177	0.179	0.403	0.445	0.263
	0.410	0.413	0.352	0.062	0.182	0.125
ACTUAL EVAPOTRANSPIRATION						

TOTALS	1.193	1.541	2.190	3.180	4.706	4.073
	4.978	3.914	2.729	1.267	0.914	0.791
STD. DEVIATIONS	0.095	0.154	0.276	0.684	1.211	1.405
	1.282	1.455	1.165	0.187	0.268	0.186
LATERAL DRAINAGE COLLECTED FROM LAYER 6						

TOTALS	1.0811	1.5403	1.7096	1.2263	1.4707	1.2420
	1.1218	1.0789	1.7655	1.4896	0.8001	0.6373
STD. DEVIATIONS	1.1101	1.3009	1.5602	1.1621	0.6397	0.3121
	0.1513	0.3646	2.0392	1.8273	0.6202	0.4161
LATERAL DRAINAGE RECIRCULATED FROM LAYER 6 INTO L. 1						

TOTALS	0.0000	0.0000	0.0000	0.0000	0.0000	0.0000
	0.0000	0.0000	0.0000	0.0000	0.0000	0.0000
STD. DEVIATIONS	0.0000	0.0000	0.0000	0.0000	0.0000	0.0000
	0.0000	0.0000	0.0000	0.0000	0.0000	0.0000
PERCOLATION/LEAKAGE THROUGH LAYER 8						

TOTALS	0.0000	0.0000	0.0000	0.0000	0.0000	0.0000
	0.0000	0.0000	0.0000	0.0000	0.0000	0.0000
STD. DEVIATIONS	0.0000	0.0000	0.0000	0.0000	0.0000	0.0000
	0.0000	0.0000	0.0000	0.0000	0.0000	0.0000
PERCOLATION/LEAKAGE THROUGH LAYER 9						

TOTALS	0.0000	0.0000	0.0000	0.0000	0.0000	0.0000
	0.0000	0.0000	0.0000	0.0000	0.0000	0.0000
STD. DEVIATIONS	0.0000	0.0000	0.0000	0.0000	0.0000	0.0000
	0.0000	0.0000	0.0000	0.0000	0.0000	0.0000

 AVERAGES OF MONTHLY AVERAGED DAILY HEADS (INCHES)

DAILY AVERAGE HEAD ON TOP OF LAYER 7

AVERAGES	0.0381	0.1849	0.0602	0.0446	0.0518	0.0452
	0.0395	0.0380	1.1528	0.4241	0.0291	0.0224
STD. DEVIATIONS	0.0391	0.3145	0.0549	0.0423	0.0225	0.0113
	0.0053	0.0128	2.5079	0.8954	0.0226	0.0146

AVERAGE ANNUAL TOTALS & (STD. DEVIATIONS) FOR YEARS 1 THROUGH 5

	INCHES		CU. FEET	PERCENT
	-----	-----	-----	-----
PRECIPITATION	45.08	(10.212)	163625.9	100.00
RUNOFF	0.000	(0.0000)	0.00	0.000
POTENTIAL EVAPOTRANSPIRATION	49.932	(0.3704)	181254.19	
ACTUAL EVAPOTRANSPIRATION	31.475	(1.0157)	114254.23	69.827
LATERAL DRAINAGE COLLECTED FROM LAYER 6	15.16304	(8.99294)	55041.844	33.63884
DRAINAGE RECIRCULATED FROM LAYER 6 INTO L. 1	0.00000	(0.00000)	0.000	0.00000
PERCOLATION/LEAKAGE THROUGH LAYER 8	0.00002	(0.00004)	0.071	0.00004
AVERAGE HEAD ON TOP OF LAYER 7	0.178	(0.321)		
PERCOLATION/LEAKAGE THROUGH LAYER 9	0.00002	(0.00004)	0.071	0.00004
CHANGE IN WATER STORAGE	-1.562	(4.5481)	-5670.26	-3.465

```

*****
*****
**
**
**          HYDROLOGIC EVALUATION OF LANDFILL PERFORMANCE          **
**
**          HELP Version 3.95 D          (10 August 2012)          **
**                    developed at          **
** Institute of Soil Science, University of Hamburg, Germany      **
**                    based on          **
**          US HELP MODEL VERSION 3.07 (1 NOVEMBER 1997)          **
**          DEVELOPED BY ENVIRONMENTAL LABORATORY          **
**          USAE WATERWAYS EXPERIMENT STATION          **
**          FOR USEPA RISK REDUCTION ENGINEERING LABORATORY          **
**
**
*****
*****

```

TIME: 9.48 DATE: 8.03.2015

```

PRECIPITATION DATA FILE: C:\Users\mplummer\Desktop\HELP runs\Weather Data\SF
Charah Sanford 25 yr storm y3m8d16.d4
TEMPERATURE DATA FILE: C:\Users\mplummer\Desktop\HELP runs\Weather
Data\Charah Sanford.d7
SOLAR RADIATION DATA FILE: C:\Users\mplummer\Desktop\HELP runs\Weather
Data\Charah Sanford.d13
EVAPOTRANSPIRATION DATA F. 1: C:\Users\mplummer\Desktop\HELP runs\Weather
Data\Charah Sanford.d11
SOIL AND DESIGN DATA FILE 1: C:\Users\mplummer\Desktop\HELP runs\Eric's
Runs\MPColon 5-2ft lifts no runoff 1%425.d10
OUTPUT DATA FILE: C:\Users\mplummer\Desktop\HELP runs\1.0% MPrevised.out

```

```

*****
TITLE: Coal Ash-First Lift (Ten 2-foot Lifts, No Runoff, 1% slope)
*****

```

WEATHER DATA SOURCES

NOTE: PRECIPITATION DATA FOR RALEIGH NORTH CAROLINA
WAS ENTERED BY THE USER.

NOTE: TEMPERATURE DATA WAS SYNTHETICALLY GENERATED USING
COEFFICIENTS FOR RALEIGH NORTH CAROLINA

NORMAL MEAN MONTHLY TEMPERATURE (DEGREES FAHRENHEIT)

JAN/JUL	FEB/AUG	MAR/SEP	APR/OCT	MAY/NOV	JUN/DEC
---------	---------	---------	---------	---------	---------

39.60	41.60	49.30	59.50	67.20	73.90
77.70	77.00	71.00	59.70	50.00	42.00

NOTE: SOLAR RADIATION DATA WAS SYNTHETICALLY GENERATED USING
 COEFFICIENTS FOR RALEIGH NORTH CAROLINA
 AND STATION LATITUDE = 35.87 DEGREES

LAYER DATA 1

VALID FOR 5 YEARS

NOTE: INITIAL MOISTURE CONTENT OF THE LAYERS AND SNOW WATER
 WERE SPECIFIED BY THE USER.

LAYER 1

TYPE 1 - VERTICAL PERCOLATION LAYER

MATERIAL TEXTURE NUMBER 0

THICKNESS = 24.00 INCHES
 POROSITY = 0.5410 VOL/VOL
 FIELD CAPACITY = 0.1870 VOL/VOL
 WILTING POINT = 0.0470 VOL/VOL
 INITIAL SOIL WATER CONTENT = 0.3100 VOL/VOL
 EFFECTIVE SAT. HYD. CONDUCT.= 0.1600E-03 CM/SEC

LAYER 2

TYPE 1 - VERTICAL PERCOLATION LAYER

MATERIAL TEXTURE NUMBER 0

THICKNESS = 24.00 INCHES
 POROSITY = 0.5410 VOL/VOL
 FIELD CAPACITY = 0.1870 VOL/VOL
 WILTING POINT = 0.0470 VOL/VOL
 INITIAL SOIL WATER CONTENT = 0.3100 VOL/VOL
 EFFECTIVE SAT. HYD. CONDUCT.= 0.1600E-03 CM/SEC

LAYER 3

TYPE 1 - VERTICAL PERCOLATION LAYER

MATERIAL TEXTURE NUMBER 0

THICKNESS = 24.00 INCHES
 POROSITY = 0.5410 VOL/VOL

FIELD CAPACITY = 0.1870 VOL/VOL
 WILTING POINT = 0.0470 VOL/VOL
 INITIAL SOIL WATER CONTENT = 0.3100 VOL/VOL
 EFFECTIVE SAT. HYD. CONDUCT.= 0.1600E-03 CM/SEC

LAYER 4

TYPE 1 - VERTICAL PERCOLATION LAYER

MATERIAL TEXTURE NUMBER 0

THICKNESS = 24.00 INCHES
 POROSITY = 0.5410 VOL/VOL
 FIELD CAPACITY = 0.1870 VOL/VOL
 WILTING POINT = 0.0470 VOL/VOL
 INITIAL SOIL WATER CONTENT = 0.3100 VOL/VOL
 EFFECTIVE SAT. HYD. CONDUCT.= 0.1600E-03 CM/SEC

LAYER 5

TYPE 1 - VERTICAL PERCOLATION LAYER

MATERIAL TEXTURE NUMBER 0

THICKNESS = 24.00 INCHES
 POROSITY = 0.5410 VOL/VOL
 FIELD CAPACITY = 0.1870 VOL/VOL
 WILTING POINT = 0.0470 VOL/VOL
 INITIAL SOIL WATER CONTENT = 0.3100 VOL/VOL
 EFFECTIVE SAT. HYD. CONDUCT.= 0.1600E-03 CM/SEC

LAYER 6

TYPE 2 - LATERAL DRAINAGE LAYER

MATERIAL TEXTURE NUMBER 0

THICKNESS = 0.26 INCHES
 POROSITY = 0.8500 VOL/VOL
 FIELD CAPACITY = 0.0100 VOL/VOL
 WILTING POINT = 0.0050 VOL/VOL
 INITIAL SOIL WATER CONTENT = 0.0100 VOL/VOL
 EFFECTIVE SAT. HYD. CONDUCT.= 9.700 CM/SEC
 SLOPE = 1.00 PERCENT
 DRAINAGE LENGTH = 425.0 FEET

LAYER 7

TYPE 4 - FLEXIBLE MEMBRANE LINER

MATERIAL TEXTURE NUMBER 35

THICKNESS = 0.06 INCHES
 EFFECTIVE SAT. HYD. CONDUCT.= 0.2000E-12 CM/SEC
 FML PINHOLE DENSITY = 1.00 HOLES/ACRE
 FML INSTALLATION DEFECTS = 1.00 HOLES/ACRE

FML PLACEMENT QUALITY = 3 - GOOD

LAYER 8

TYPE 3 - BARRIER SOIL LINER
MATERIAL TEXTURE NUMBER 17

THICKNESS = 0.25 INCHES
 POROSITY = 0.7500 VOL/VOL
 FIELD CAPACITY = 0.7470 VOL/VOL
 WILTING POINT = 0.4000 VOL/VOL
 INITIAL SOIL WATER CONTENT = 0.7500 VOL/VOL
 EFFECTIVE SAT. HYD. CONDUCT.= 0.3000E-08 CM/SEC

LAYER 9

TYPE 1 - VERTICAL PERCOLATION LAYER
MATERIAL TEXTURE NUMBER 16

THICKNESS = 18.00 INCHES
 POROSITY = 0.4270 VOL/VOL
 FIELD CAPACITY = 0.4180 VOL/VOL
 WILTING POINT = 0.3670 VOL/VOL
 INITIAL SOIL WATER CONTENT = 0.4180 VOL/VOL
 EFFECTIVE SAT. HYD. CONDUCT.= 0.1000E-06 CM/SEC

GENERAL DESIGN AND EVAPORATIVE ZONE DATA 1

VALID FOR 5 YEARS

NOTE: SCS RUNOFF CURVE NUMBER WAS COMPUTED FROM DEFAULT SOIL DATA BASE USING SOIL TEXTURE # 9 WITH BARE GROUND CONDITIONS, A SURFACE SLOPE OF 2.% AND A SLOPE LENGTH OF 1000. FEET.

SCS RUNOFF CURVE NUMBER = 91.21
 FRACTION OF AREA ALLOWING RUNOFF = 0.0 PERCENT
 AREA PROJECTED ON HORIZONTAL PLANE = 1.000 ACRES
 EVAPORATIVE ZONE DEPTH = 18.0 INCHES
 INITIAL WATER IN EVAPORATIVE ZONE = 5.580 INCHES
 UPPER LIMIT OF EVAPORATIVE STORAGE = 9.738 INCHES
 FIELD CAPACITY OF EVAPORATIVE ZONE = 3.366 INCHES
 LOWER LIMIT OF EVAPORATIVE STORAGE = 0.846 INCHES
 SOIL EVAPORATION ZONE DEPTH = 18.000 INCHES
 INITIAL SNOW WATER = 0.000 INCHES
 INITIAL INTERCEPTION WATER = 0.000 INCHES
 INITIAL WATER IN LAYER MATERIALS = 44.914 INCHES
 TOTAL INITIAL WATER = 44.914 INCHES
 TOTAL SUBSURFACE INFLOW = 0.00 INCHES/YEAR

EVAPOTRANSPIRATION DATA 1

VALID FOR 5 YEARS

NOTE: EVAPOTRANSPIRATION DATA WAS OBTAINED FROM
RALEIGH NORTH CAROLINA

STATION LATITUDE = 35.87 DEGREES
 MAXIMUM LEAF AREA INDEX = 4.50
 START OF GROWING SEASON (JULIAN DATE) = 86
 END OF GROWING SEASON (JULIAN DATE) = 310
 EVAPORATIVE ZONE DEPTH = 18.0 INCHES
 AVERAGE ANNUAL WIND SPEED = 7.70 MPH
 AVERAGE 1ST QUARTER RELATIVE HUMIDITY = 66.0 %
 AVERAGE 2ND QUARTER RELATIVE HUMIDITY = 70.0 %
 AVERAGE 3RD QUARTER RELATIVE HUMIDITY = 78.0 %
 AVERAGE 4TH QUARTER RELATIVE HUMIDITY = 72.0 %

FINAL WATER STORAGE AT END OF YEAR 5

LAYER	(INCHES)	(VOL/VOL)
----	-----	-----
1	7.0193	0.2925
2	6.3803	0.2658
3	4.8629	0.2026
4	5.4737	0.2281
5	5.6427	0.2351
6	0.0102	0.0400
7	0.0000	0.0000
8	0.1875	0.7500
9	7.5240	0.4180
TOTAL WATER IN LAYERS	37.101	
SNOW WATER	0.000	
INTERCEPTION WATER	0.000	
TOTAL FINAL WATER	37.101	

PEAK DAILY VALUES FOR YEARS	1 THROUGH	5
	(INCHES)	(CU. FT.)
PRECIPITATION	6.28	22796.400
RUNOFF	0.000	0.0000
DRAINAGE COLLECTED FROM LAYER 6	0.33137	1202.88806
PERCOLATION/LEAKAGE THROUGH LAYER 8	0.000003	0.00928
AVERAGE HEAD ON TOP OF LAYER 7	8.229	
MAXIMUM HEAD ON TOP OF LAYER 7	11.579	
LOCATION OF MAXIMUM HEAD IN LAYER 6 (DISTANCE FROM DRAIN)	125.9 FEET	
PERCOLATION/LEAKAGE THROUGH LAYER 9	0.000003	0.00928
SNOW WATER	1.67	6061.1177
MAXIMUM VEG. SOIL WATER (VOL/VOL)		0.5112
MINIMUM VEG. SOIL WATER (VOL/VOL)		0.0470

*** Maximum heads are computed using McEnroe's equations. ***

Reference: Maximum Saturated Depth over Landfill Liner
by Bruce M. McEnroe, University of Kansas
ASCE Journal of Environmental Engineering
Vol. 119, No. 2, March 1993, pp. 262-270.

AVERAGE MONTHLY VALUES IN INCHES FOR YEARS	1 THROUGH 5					
	JAN/JUL	FEB/AUG	MAR/SEP	APR/OCT	MAY/NOV	JUN/DEC
PRECIPITATION						
TOTALS	3.26 4.57	2.82 6.47	4.37 2.81	2.63 3.77	3.53 2.52	5.42 2.90

STD. DEVIATIONS	2.96	0.95	1.30	1.89	2.64	1.99
	2.29	6.38	1.69	2.69	1.66	1.28
RUNOFF						

TOTALS	0.000	0.000	0.000	0.000	0.000	0.000
	0.000	0.000	0.000	0.000	0.000	0.000
STD. DEVIATIONS	0.000	0.000	0.000	0.000	0.000	0.000
	0.000	0.000	0.000	0.000	0.000	0.000
POTENTIAL EVAPOTRANSPIRATION						

TOTALS	1.892	2.205	3.293	4.787	6.327	6.770
	7.049	5.890	4.466	3.365	2.345	1.543
STD. DEVIATIONS	0.140	0.177	0.179	0.403	0.445	0.263
	0.410	0.413	0.352	0.062	0.182	0.125
ACTUAL EVAPOTRANSPIRATION						

TOTALS	1.193	1.541	2.190	3.180	4.706	4.073
	4.978	3.914	2.729	1.267	0.914	0.791
STD. DEVIATIONS	0.095	0.154	0.276	0.684	1.211	1.405
	1.282	1.455	1.165	0.187	0.268	0.186
LATERAL DRAINAGE COLLECTED FROM LAYER 6						

TOTALS	1.0875	1.5479	1.6994	1.2303	1.4695	1.2391
	1.1239	1.0751	1.9755	1.2807	0.7978	0.6370
STD. DEVIATIONS	1.1199	1.3097	1.5510	1.1613	0.6345	0.3115
	0.1497	0.3632	2.5108	1.3641	0.6164	0.4172
LATERAL DRAINAGE RECIRCULATED FROM LAYER 6 INTO L. 1						

TOTALS	0.0000	0.0000	0.0000	0.0000	0.0000	0.0000
	0.0000	0.0000	0.0000	0.0000	0.0000	0.0000
STD. DEVIATIONS	0.0000	0.0000	0.0000	0.0000	0.0000	0.0000
	0.0000	0.0000	0.0000	0.0000	0.0000	0.0000
PERCOLATION/LEAKAGE THROUGH LAYER 8						

TOTALS	0.0000	0.0000	0.0000	0.0000	0.0000	0.0000
	0.0000	0.0000	0.0000	0.0000	0.0000	0.0000
STD. DEVIATIONS	0.0000	0.0000	0.0000	0.0000	0.0000	0.0000
	0.0000	0.0000	0.0000	0.0000	0.0000	0.0000
PERCOLATION/LEAKAGE THROUGH LAYER 9						

TOTALS	0.0000	0.0000	0.0000	0.0000	0.0000	0.0000
	0.0000	0.0000	0.0000	0.0000	0.0000	0.0000
STD. DEVIATIONS	0.0000	0.0000	0.0000	0.0000	0.0000	0.0000
	0.0000	0.0000	0.0000	0.0000	0.0000	0.0000

 AVERAGES OF MONTHLY AVERAGED DAILY HEADS (INCHES)

DAILY AVERAGE HEAD ON TOP OF LAYER 7

AVERAGES	0.0271	0.0425	0.0424	0.0317	0.0366	0.0319
	0.0280	0.0268	0.8151	0.0319	0.0206	0.0159
STD. DEVIATIONS	0.0279	0.0362	0.0387	0.0299	0.0158	0.0080
	0.0037	0.0091	1.7732	0.0340	0.0159	0.0104

AVERAGE ANNUAL TOTALS & (STD. DEVIATIONS) FOR YEARS 1 THROUGH 5

	INCHES		CU. FEET	PERCENT
	-----	-----	-----	-----
PRECIPITATION	45.08	(10.212)	163625.9	100.00
RUNOFF	0.000	(0.0000)	0.00	0.000
POTENTIAL EVAPOTRANSPIRATION	49.932	(0.3704)	181254.19	
ACTUAL EVAPOTRANSPIRATION	31.475	(1.0157)	114254.23	69.827
LATERAL DRAINAGE COLLECTED FROM LAYER 6	15.16367	(8.99710)	55044.137	33.64024
DRAINAGE RECIRCULATED FROM LAYER 6 INTO L. 1	0.00000	(0.00000)	0.000	0.00000
PERCOLATION/LEAKAGE THROUGH LAYER 8	0.00001	(0.00002)	0.039	0.00002
AVERAGE HEAD ON TOP OF LAYER 7	0.096	(0.161)		
PERCOLATION/LEAKAGE THROUGH LAYER 9	0.00001	(0.00002)	0.039	0.00002
CHANGE IN WATER STORAGE	-1.563	(4.5465)	-5672.52	-3.467

```

*****
*****
**
**
**          HYDROLOGIC EVALUATION OF LANDFILL PERFORMANCE          **
**
**          HELP Version 3.95 D          (10 August 2012)          **
**                    developed at          **
** Institute of Soil Science, University of Hamburg, Germany      **
**                    based on          **
**          US HELP MODEL VERSION 3.07 (1 NOVEMBER 1997)          **
**          DEVELOPED BY ENVIRONMENTAL LABORATORY          **
**          USAE WATERWAYS EXPERIMENT STATION          **
**          FOR USEPA RISK REDUCTION ENGINEERING LABORATORY          **
**
**
*****
*****

```

TIME: 9.58 DATE: 8.03.2015

```

PRECIPITATION DATA FILE: C:\Users\mplummer\Desktop\HELP runs\Weather Data\SF
Charah Sanford 25 yr storm y3m8d16.d4
TEMPERATURE DATA FILE: C:\Users\mplummer\Desktop\HELP runs\Weather
Data\Charah Sanford.d7
SOLAR RADIATION DATA FILE: C:\Users\mplummer\Desktop\HELP runs\Weather
Data\Charah Sanford.d13
EVAPOTRANSPIRATION DATA F. 1: C:\Users\mplummer\Desktop\HELP runs\Weather
Data\Charah Sanford.d11
SOIL AND DESIGN DATA FILE 1: C:\Users\mplummer\Desktop\HELP runs\MP Colon 5-2ft
lifts no runoff 2%.d10
OUTPUT DATA FILE: C:\Users\mplummer\Desktop\HELP runs\2.0% MPrevised.out

```

```

*****
TITLE: Coal Ash-First Lift (Five 2-foot Lifts, No Runoff)
*****

```

WEATHER DATA SOURCES

NOTE: PRECIPITATION DATA FOR RALEIGH NORTH CAROLINA
WAS ENTERED BY THE USER.

NOTE: TEMPERATURE DATA WAS SYNTHETICALLY GENERATED USING
COEFFICIENTS FOR RALEIGH NORTH CAROLINA

NORMAL MEAN MONTHLY TEMPERATURE (DEGREES FAHRENHEIT)

JAN/JUL	FEB/AUG	MAR/SEP	APR/OCT	MAY/NOV	JUN/DEC
---------	---------	---------	---------	---------	---------

39.60	41.60	49.30	59.50	67.20	73.90
77.70	77.00	71.00	59.70	50.00	42.00

NOTE: SOLAR RADIATION DATA WAS SYNTHETICALLY GENERATED USING
 COEFFICIENTS FOR RALEIGH NORTH CAROLINA
 AND STATION LATITUDE = 35.87 DEGREES

LAYER DATA 1

VALID FOR 5 YEARS

NOTE: INITIAL MOISTURE CONTENT OF THE LAYERS AND SNOW WATER
 WERE SPECIFIED BY THE USER.

LAYER 1

TYPE 1 - VERTICAL PERCOLATION LAYER

MATERIAL TEXTURE NUMBER 0

THICKNESS = 24.00 INCHES
 POROSITY = 0.5410 VOL/VOL
 FIELD CAPACITY = 0.1870 VOL/VOL
 WILTING POINT = 0.0470 VOL/VOL
 INITIAL SOIL WATER CONTENT = 0.3100 VOL/VOL
 EFFECTIVE SAT. HYD. CONDUCT.= 0.1600E-03 CM/SEC

LAYER 2

TYPE 1 - VERTICAL PERCOLATION LAYER

MATERIAL TEXTURE NUMBER 0

THICKNESS = 24.00 INCHES
 POROSITY = 0.5410 VOL/VOL
 FIELD CAPACITY = 0.1870 VOL/VOL
 WILTING POINT = 0.0470 VOL/VOL
 INITIAL SOIL WATER CONTENT = 0.3100 VOL/VOL
 EFFECTIVE SAT. HYD. CONDUCT.= 0.1600E-03 CM/SEC

LAYER 3

TYPE 1 - VERTICAL PERCOLATION LAYER

MATERIAL TEXTURE NUMBER 0

THICKNESS = 24.00 INCHES
 POROSITY = 0.5410 VOL/VOL

FIELD CAPACITY = 0.1870 VOL/VOL
 WILTING POINT = 0.0470 VOL/VOL
 INITIAL SOIL WATER CONTENT = 0.3100 VOL/VOL
 EFFECTIVE SAT. HYD. CONDUCT.= 0.1600E-03 CM/SEC

LAYER 4

TYPE 1 - VERTICAL PERCOLATION LAYER
 MATERIAL TEXTURE NUMBER 0

THICKNESS = 24.00 INCHES
 POROSITY = 0.5410 VOL/VOL
 FIELD CAPACITY = 0.1870 VOL/VOL
 WILTING POINT = 0.0470 VOL/VOL
 INITIAL SOIL WATER CONTENT = 0.3100 VOL/VOL
 EFFECTIVE SAT. HYD. CONDUCT.= 0.1600E-03 CM/SEC

LAYER 5

TYPE 1 - VERTICAL PERCOLATION LAYER
 MATERIAL TEXTURE NUMBER 0

THICKNESS = 24.00 INCHES
 POROSITY = 0.5410 VOL/VOL
 FIELD CAPACITY = 0.1870 VOL/VOL
 WILTING POINT = 0.0470 VOL/VOL
 INITIAL SOIL WATER CONTENT = 0.3100 VOL/VOL
 EFFECTIVE SAT. HYD. CONDUCT.= 0.1600E-03 CM/SEC

LAYER 6

TYPE 2 - LATERAL DRAINAGE LAYER
 MATERIAL TEXTURE NUMBER 0

THICKNESS = 0.26 INCHES
 POROSITY = 0.8500 VOL/VOL
 FIELD CAPACITY = 0.0100 VOL/VOL
 WILTING POINT = 0.0050 VOL/VOL
 INITIAL SOIL WATER CONTENT = 0.0100 VOL/VOL
 EFFECTIVE SAT. HYD. CONDUCT.= 9.700 CM/SEC
 SLOPE = 2.00 PERCENT
 DRAINAGE LENGTH = 600.0 FEET

LAYER 7

TYPE 4 - FLEXIBLE MEMBRANE LINER
 MATERIAL TEXTURE NUMBER 35

THICKNESS = 0.06 INCHES
 EFFECTIVE SAT. HYD. CONDUCT.= 0.2000E-12 CM/SEC
 FML PINHOLE DENSITY = 1.00 HOLES/ACRE
 FML INSTALLATION DEFECTS = 1.00 HOLES/ACRE

FML PLACEMENT QUALITY = 3 - GOOD

LAYER 8

TYPE 3 - BARRIER SOIL LINER
 MATERIAL TEXTURE NUMBER 17

THICKNESS = 0.25 INCHES
 POROSITY = 0.7500 VOL/VOL
 FIELD CAPACITY = 0.7470 VOL/VOL
 WILTING POINT = 0.4000 VOL/VOL
 INITIAL SOIL WATER CONTENT = 0.7500 VOL/VOL
 EFFECTIVE SAT. HYD. CONDUCT.= 0.3000E-08 CM/SEC

LAYER 9

TYPE 1 - VERTICAL PERCOLATION LAYER
 MATERIAL TEXTURE NUMBER 16

THICKNESS = 18.00 INCHES
 POROSITY = 0.4270 VOL/VOL
 FIELD CAPACITY = 0.4180 VOL/VOL
 WILTING POINT = 0.3670 VOL/VOL
 INITIAL SOIL WATER CONTENT = 0.4180 VOL/VOL
 EFFECTIVE SAT. HYD. CONDUCT.= 0.1000E-06 CM/SEC

GENERAL DESIGN AND EVAPORATIVE ZONE DATA 1

VALID FOR 5 YEARS

NOTE: SCS RUNOFF CURVE NUMBER WAS COMPUTED FROM DEFAULT SOIL DATA BASE USING SOIL TEXTURE # 9 WITH BARE GROUND CONDITIONS, A SURFACE SLOPE OF 2.% AND A SLOPE LENGTH OF 1000. FEET.

SCS RUNOFF CURVE NUMBER = 91.21
 FRACTION OF AREA ALLOWING RUNOFF = 0.0 PERCENT
 AREA PROJECTED ON HORIZONTAL PLANE = 1.000 ACRES
 EVAPORATIVE ZONE DEPTH = 18.0 INCHES
 INITIAL WATER IN EVAPORATIVE ZONE = 5.580 INCHES
 UPPER LIMIT OF EVAPORATIVE STORAGE = 9.738 INCHES
 FIELD CAPACITY OF EVAPORATIVE ZONE = 3.366 INCHES
 LOWER LIMIT OF EVAPORATIVE STORAGE = 0.846 INCHES
 SOIL EVAPORATION ZONE DEPTH = 18.000 INCHES
 INITIAL SNOW WATER = 0.000 INCHES
 INITIAL INTERCEPTION WATER = 0.000 INCHES
 INITIAL WATER IN LAYER MATERIALS = 44.914 INCHES
 TOTAL INITIAL WATER = 44.914 INCHES
 TOTAL SUBSURFACE INFLOW = 0.00 INCHES/YEAR

EVAPOTRANSPIRATION DATA 1

VALID FOR 5 YEARS

NOTE: EVAPOTRANSPIRATION DATA WAS OBTAINED FROM
RALEIGH NORTH CAROLINA

STATION LATITUDE = 35.87 DEGREES
 MAXIMUM LEAF AREA INDEX = 4.50
 START OF GROWING SEASON (JULIAN DATE) = 86
 END OF GROWING SEASON (JULIAN DATE) = 310
 EVAPORATIVE ZONE DEPTH = 18.0 INCHES
 AVERAGE ANNUAL WIND SPEED = 7.70 MPH
 AVERAGE 1ST QUARTER RELATIVE HUMIDITY = 66.0 %
 AVERAGE 2ND QUARTER RELATIVE HUMIDITY = 70.0 %
 AVERAGE 3RD QUARTER RELATIVE HUMIDITY = 78.0 %
 AVERAGE 4TH QUARTER RELATIVE HUMIDITY = 72.0 %

FINAL WATER STORAGE AT END OF YEAR 5

LAYER	(INCHES)	(VOL/VOL)
----	-----	-----
1	7.0193	0.2925
2	6.3803	0.2658
3	4.8629	0.2026
4	5.4737	0.2281
5	5.6427	0.2351
6	0.0080	0.0313
7	0.0000	0.0000
8	0.1875	0.7500
9	7.5240	0.4180
TOTAL WATER IN LAYERS	37.098	
SNOW WATER	0.000	
INTERCEPTION WATER	0.000	
TOTAL FINAL WATER	37.098	

PEAK DAILY VALUES FOR YEARS	1 THROUGH 5	
	(INCHES)	(CU. FT.)
PRECIPITATION	6.28	22796.400
RUNOFF	0.000	0.0000
DRAINAGE COLLECTED FROM LAYER 6	0.46927	1703.43982
PERCOLATION/LEAKAGE THROUGH LAYER 8	0.000002	0.00739
AVERAGE HEAD ON TOP OF LAYER 7	6.946	
MAXIMUM HEAD ON TOP OF LAYER 7	11.642	
LOCATION OF MAXIMUM HEAD IN LAYER 6 (DISTANCE FROM DRAIN)	97.0 FEET	
PERCOLATION/LEAKAGE THROUGH LAYER 9	0.000002	0.00739
SNOW WATER	1.67	6061.1177
MAXIMUM VEG. SOIL WATER (VOL/VOL)		0.5112
MINIMUM VEG. SOIL WATER (VOL/VOL)		0.0470

*** Maximum heads are computed using McEnroe's equations. ***

Reference: Maximum Saturated Depth over Landfill Liner
by Bruce M. McEnroe, University of Kansas
ASCE Journal of Environmental Engineering
Vol. 119, No. 2, March 1993, pp. 262-270.

AVERAGE MONTHLY VALUES IN INCHES FOR YEARS	1 THROUGH 5					
	JAN/JUL	FEB/AUG	MAR/SEP	APR/OCT	MAY/NOV	JUN/DEC
PRECIPITATION						
TOTALS	3.26 4.57	2.82 6.47	4.37 2.81	2.63 3.77	3.53 2.52	5.42 2.90

STD. DEVIATIONS	2.96	0.95	1.30	1.89	2.64	1.99
	2.29	6.38	1.69	2.69	1.66	1.28
RUNOFF						

TOTALS	0.000	0.000	0.000	0.000	0.000	0.000
	0.000	0.000	0.000	0.000	0.000	0.000
STD. DEVIATIONS	0.000	0.000	0.000	0.000	0.000	0.000
	0.000	0.000	0.000	0.000	0.000	0.000
POTENTIAL EVAPOTRANSPIRATION						

TOTALS	1.892	2.205	3.293	4.787	6.327	6.770
	7.049	5.890	4.466	3.365	2.345	1.543
STD. DEVIATIONS	0.140	0.177	0.179	0.403	0.445	0.263
	0.410	0.413	0.352	0.062	0.182	0.125
ACTUAL EVAPOTRANSPIRATION						

TOTALS	1.193	1.541	2.190	3.180	4.706	4.073
	4.978	3.914	2.729	1.267	0.914	0.791
STD. DEVIATIONS	0.095	0.154	0.276	0.684	1.211	1.405
	1.282	1.455	1.165	0.187	0.268	0.186
LATERAL DRAINAGE COLLECTED FROM LAYER 6						

TOTALS	1.0921	1.5520	1.6936	1.2330	1.4686	1.2369
	1.1256	1.0726	1.9861	1.2707	0.7960	0.6370
STD. DEVIATIONS	1.1270	1.3140	1.5478	1.1602	0.6308	0.3112
	0.1489	0.3622	2.5376	1.3439	0.6135	0.4182
LATERAL DRAINAGE RECIRCULATED FROM LAYER 6 INTO L. 1						

TOTALS	0.0000	0.0000	0.0000	0.0000	0.0000	0.0000
	0.0000	0.0000	0.0000	0.0000	0.0000	0.0000
STD. DEVIATIONS	0.0000	0.0000	0.0000	0.0000	0.0000	0.0000
	0.0000	0.0000	0.0000	0.0000	0.0000	0.0000
PERCOLATION/LEAKAGE THROUGH LAYER 8						

TOTALS	0.0000	0.0000	0.0000	0.0000	0.0000	0.0000
	0.0000	0.0000	0.0000	0.0000	0.0000	0.0000
STD. DEVIATIONS	0.0000	0.0000	0.0000	0.0000	0.0000	0.0000
	0.0000	0.0000	0.0000	0.0000	0.0000	0.0000
PERCOLATION/LEAKAGE THROUGH LAYER 9						

TOTALS	0.0000	0.0000	0.0000	0.0000	0.0000	0.0000
	0.0000	0.0000	0.0000	0.0000	0.0000	0.0000
STD. DEVIATIONS	0.0000	0.0000	0.0000	0.0000	0.0000	0.0000
	0.0000	0.0000	0.0000	0.0000	0.0000	0.0000

 AVERAGES OF MONTHLY AVERAGED DAILY HEADS (INCHES)

DAILY AVERAGE HEAD ON TOP OF LAYER 7

AVERAGES	0.0192	0.0301	0.0298	0.0224	0.0259	0.0225
	0.0198	0.0189	0.1901	0.0224	0.0145	0.0112
STD. DEVIATIONS	0.0198	0.0256	0.0272	0.0211	0.0111	0.0057
	0.0026	0.0064	0.3904	0.0237	0.0112	0.0074

AVERAGE ANNUAL TOTALS & (STD. DEVIATIONS) FOR YEARS 1 THROUGH 5

	INCHES		CU. FEET	PERCENT
	-----	-----	-----	-----
PRECIPITATION	45.08	(10.212)	163625.9	100.00
RUNOFF	0.000	(0.0000)	0.00	0.000
POTENTIAL EVAPOTRANSPIRATION	49.932	(0.3704)	181254.19	
ACTUAL EVAPOTRANSPIRATION	31.475	(1.0157)	114254.23	69.827
LATERAL DRAINAGE COLLECTED FROM LAYER 6	15.16413	(9.00048)	55045.793	33.64125
DRAINAGE RECIRCULATED FROM LAYER 6 INTO L. 1	0.00000	(0.00000)	0.000	0.00000
PERCOLATION/LEAKAGE THROUGH LAYER 8	0.00000	(0.00000)	0.017	0.00001
AVERAGE HEAD ON TOP OF LAYER 7	0.036	(0.042)		
PERCOLATION/LEAKAGE THROUGH LAYER 9	0.00000	(0.00000)	0.017	0.00001
CHANGE IN WATER STORAGE	-1.563	(4.5454)	-5674.15	-3.468

```

*****
*****
**
**
**          HYDROLOGIC EVALUATION OF LANDFILL PERFORMANCE          **
**
**          HELP Version 3.95 D          (10 August 2012)          **
**                    developed at          **
** Institute of Soil Science, University of Hamburg, Germany      **
**                    based on          **
**          US HELP MODEL VERSION 3.07 (1 NOVEMBER 1997)          **
**          DEVELOPED BY ENVIRONMENTAL LABORATORY          **
**          USAE WATERWAYS EXPERIMENT STATION          **
**          FOR USEPA RISK REDUCTION ENGINEERING LABORATORY          **
**
**
*****
*****

```

TIME: 10.11 DATE: 8.03.2015

```

PRECIPITATION DATA FILE:      C:\Users\mplummer\Desktop\HELP runs\Weather Data\SF
Charah Sanford 25 yr storm y3m8d16.d4
TEMPERATURE DATA FILE:      C:\Users\mplummer\Desktop\HELP runs\Weather
Data\Charah Sanford.d7
SOLAR RADIATION DATA FILE:   C:\Users\mplummer\Desktop\HELP runs\Weather
Data\Charah Sanford.d13
EVAPOTRANSPIRATION DATA F. 1: C:\Users\mplummer\Desktop\HELP runs\Weather
Data\Charah Sanford.d11
SOIL AND DESIGN DATA FILE 1: C:\Users\mplummer\Desktop\HELP runs\Mike's
runs\MPColon 5-2ft lifts no runoff 3%.d10
OUTPUT DATA FILE:          C:\Users\mplummer\Desktop\HELP runs\3.0% MPrevised.out

```

```

*****
TITLE: Coal Ash-First Lift (Five 2-foot Lifts, No Runoff)
*****

```

WEATHER DATA SOURCES

NOTE: PRECIPITATION DATA FOR RALEIGH NORTH CAROLINA
WAS ENTERED BY THE USER.

NOTE: TEMPERATURE DATA WAS SYNTHETICALLY GENERATED USING
COEFFICIENTS FOR RALEIGH NORTH CAROLINA

NORMAL MEAN MONTHLY TEMPERATURE (DEGREES FAHRENHEIT)

JAN/JUL	FEB/AUG	MAR/SEP	APR/OCT	MAY/NOV	JUN/DEC
---------	---------	---------	---------	---------	---------

39.60	41.60	49.30	59.50	67.20	73.90
77.70	77.00	71.00	59.70	50.00	42.00

NOTE: SOLAR RADIATION DATA WAS SYNTHETICALLY GENERATED USING
 COEFFICIENTS FOR RALEIGH NORTH CAROLINA
 AND STATION LATITUDE = 35.87 DEGREES

LAYER DATA 1

VALID FOR 5 YEARS

NOTE: INITIAL MOISTURE CONTENT OF THE LAYERS AND SNOW WATER
 WERE SPECIFIED BY THE USER.

LAYER 1

TYPE 1 - VERTICAL PERCOLATION LAYER

MATERIAL TEXTURE NUMBER 0

THICKNESS = 24.00 INCHES
 POROSITY = 0.5410 VOL/VOL
 FIELD CAPACITY = 0.1870 VOL/VOL
 WILTING POINT = 0.0470 VOL/VOL
 INITIAL SOIL WATER CONTENT = 0.3100 VOL/VOL
 EFFECTIVE SAT. HYD. CONDUCT.= 0.1600E-03 CM/SEC

LAYER 2

TYPE 1 - VERTICAL PERCOLATION LAYER

MATERIAL TEXTURE NUMBER 0

THICKNESS = 24.00 INCHES
 POROSITY = 0.5410 VOL/VOL
 FIELD CAPACITY = 0.1870 VOL/VOL
 WILTING POINT = 0.0470 VOL/VOL
 INITIAL SOIL WATER CONTENT = 0.3100 VOL/VOL
 EFFECTIVE SAT. HYD. CONDUCT.= 0.1600E-03 CM/SEC

LAYER 3

TYPE 1 - VERTICAL PERCOLATION LAYER

MATERIAL TEXTURE NUMBER 0

THICKNESS = 24.00 INCHES
 POROSITY = 0.5410 VOL/VOL

FIELD CAPACITY = 0.1870 VOL/VOL
 WILTING POINT = 0.0470 VOL/VOL
 INITIAL SOIL WATER CONTENT = 0.3100 VOL/VOL
 EFFECTIVE SAT. HYD. CONDUCT.= 0.1600E-03 CM/SEC

LAYER 4

TYPE 1 - VERTICAL PERCOLATION LAYER
 MATERIAL TEXTURE NUMBER 0

THICKNESS = 24.00 INCHES
 POROSITY = 0.5410 VOL/VOL
 FIELD CAPACITY = 0.1870 VOL/VOL
 WILTING POINT = 0.0470 VOL/VOL
 INITIAL SOIL WATER CONTENT = 0.3100 VOL/VOL
 EFFECTIVE SAT. HYD. CONDUCT.= 0.1600E-03 CM/SEC

LAYER 5

TYPE 1 - VERTICAL PERCOLATION LAYER
 MATERIAL TEXTURE NUMBER 0

THICKNESS = 24.00 INCHES
 POROSITY = 0.5410 VOL/VOL
 FIELD CAPACITY = 0.1870 VOL/VOL
 WILTING POINT = 0.0470 VOL/VOL
 INITIAL SOIL WATER CONTENT = 0.3100 VOL/VOL
 EFFECTIVE SAT. HYD. CONDUCT.= 0.1600E-03 CM/SEC

LAYER 6

TYPE 2 - LATERAL DRAINAGE LAYER
 MATERIAL TEXTURE NUMBER 0

THICKNESS = 0.26 INCHES
 POROSITY = 0.8500 VOL/VOL
 FIELD CAPACITY = 0.0100 VOL/VOL
 WILTING POINT = 0.0050 VOL/VOL
 INITIAL SOIL WATER CONTENT = 0.0100 VOL/VOL
 EFFECTIVE SAT. HYD. CONDUCT.= 9.700 CM/SEC
 SLOPE = 3.00 PERCENT
 DRAINAGE LENGTH = 840.0 FEET

LAYER 7

TYPE 4 - FLEXIBLE MEMBRANE LINER
 MATERIAL TEXTURE NUMBER 35

THICKNESS = 0.06 INCHES
 EFFECTIVE SAT. HYD. CONDUCT.= 0.2000E-12 CM/SEC
 FML PINHOLE DENSITY = 1.00 HOLES/ACRE
 FML INSTALLATION DEFECTS = 1.00 HOLES/ACRE

FML PLACEMENT QUALITY = 3 - GOOD

LAYER 8

TYPE 3 - BARRIER SOIL LINER
MATERIAL TEXTURE NUMBER 17

THICKNESS = 0.25 INCHES
 POROSITY = 0.7500 VOL/VOL
 FIELD CAPACITY = 0.7470 VOL/VOL
 WILTING POINT = 0.4000 VOL/VOL
 INITIAL SOIL WATER CONTENT = 0.7500 VOL/VOL
 EFFECTIVE SAT. HYD. CONDUCT.= 0.3000E-08 CM/SEC

LAYER 9

TYPE 1 - VERTICAL PERCOLATION LAYER
MATERIAL TEXTURE NUMBER 16

THICKNESS = 18.00 INCHES
 POROSITY = 0.4270 VOL/VOL
 FIELD CAPACITY = 0.4180 VOL/VOL
 WILTING POINT = 0.3670 VOL/VOL
 INITIAL SOIL WATER CONTENT = 0.4180 VOL/VOL
 EFFECTIVE SAT. HYD. CONDUCT.= 0.1000E-06 CM/SEC

GENERAL DESIGN AND EVAPORATIVE ZONE DATA 1

VALID FOR 5 YEARS

NOTE: SCS RUNOFF CURVE NUMBER WAS COMPUTED FROM DEFAULT SOIL DATA BASE USING SOIL TEXTURE # 9 WITH BARE GROUND CONDITIONS, A SURFACE SLOPE OF 2.% AND A SLOPE LENGTH OF 1000. FEET.

SCS RUNOFF CURVE NUMBER = 91.21
 FRACTION OF AREA ALLOWING RUNOFF = 0.0 PERCENT
 AREA PROJECTED ON HORIZONTAL PLANE = 1.000 ACRES
 EVAPORATIVE ZONE DEPTH = 18.0 INCHES
 INITIAL WATER IN EVAPORATIVE ZONE = 5.580 INCHES
 UPPER LIMIT OF EVAPORATIVE STORAGE = 9.738 INCHES
 FIELD CAPACITY OF EVAPORATIVE ZONE = 3.366 INCHES
 LOWER LIMIT OF EVAPORATIVE STORAGE = 0.846 INCHES
 SOIL EVAPORATION ZONE DEPTH = 18.000 INCHES
 INITIAL SNOW WATER = 0.000 INCHES
 INITIAL INTERCEPTION WATER = 0.000 INCHES
 INITIAL WATER IN LAYER MATERIALS = 44.914 INCHES
 TOTAL INITIAL WATER = 44.914 INCHES
 TOTAL SUBSURFACE INFLOW = 0.00 INCHES/YEAR

EVAPOTRANSPIRATION DATA 1

VALID FOR 5 YEARS

NOTE: EVAPOTRANSPIRATION DATA WAS OBTAINED FROM
RALEIGH NORTH CAROLINA

STATION LATITUDE = 35.87 DEGREES
 MAXIMUM LEAF AREA INDEX = 4.50
 START OF GROWING SEASON (JULIAN DATE) = 86
 END OF GROWING SEASON (JULIAN DATE) = 310
 EVAPORATIVE ZONE DEPTH = 18.0 INCHES
 AVERAGE ANNUAL WIND SPEED = 7.70 MPH
 AVERAGE 1ST QUARTER RELATIVE HUMIDITY = 66.0 %
 AVERAGE 2ND QUARTER RELATIVE HUMIDITY = 70.0 %
 AVERAGE 3RD QUARTER RELATIVE HUMIDITY = 78.0 %
 AVERAGE 4TH QUARTER RELATIVE HUMIDITY = 72.0 %

FINAL WATER STORAGE AT END OF YEAR 5

LAYER	(INCHES)	(VOL/VOL)
----	-----	-----
1	7.0193	0.2925
2	6.3803	0.2658
3	4.8629	0.2026
4	5.4737	0.2281
5	5.6427	0.2351
6	0.0076	0.0299
7	0.0000	0.0000
8	0.1875	0.7500
9	7.5240	0.4180
TOTAL WATER IN LAYERS	37.098	
SNOW WATER	0.000	
INTERCEPTION WATER	0.000	
TOTAL FINAL WATER	37.098	

PEAK DAILY VALUES FOR YEARS	1 THROUGH	5
	(INCHES)	(CU. FT.)
PRECIPITATION	6.28	22796.400
RUNOFF	0.000	0.0000
DRAINAGE COLLECTED FROM LAYER 6	0.50193	1822.00183
PERCOLATION/LEAKAGE THROUGH LAYER 8	0.000002	0.00549
AVERAGE HEAD ON TOP OF LAYER 7	5.207	
MAXIMUM HEAD ON TOP OF LAYER 7	9.504	
LOCATION OF MAXIMUM HEAD IN LAYER 6 (DISTANCE FROM DRAIN)	71.8 FEET	
PERCOLATION/LEAKAGE THROUGH LAYER 9	0.000002	0.00549
SNOW WATER	1.67	6061.1177
MAXIMUM VEG. SOIL WATER (VOL/VOL)		0.5112
MINIMUM VEG. SOIL WATER (VOL/VOL)		0.0470

*** Maximum heads are computed using McEnroe's equations. ***

Reference: Maximum Saturated Depth over Landfill Liner
by Bruce M. McEnroe, University of Kansas
ASCE Journal of Environmental Engineering
Vol. 119, No. 2, March 1993, pp. 262-270.

AVERAGE MONTHLY VALUES IN INCHES FOR YEARS	1 THROUGH 5					
	JAN/JUL	FEB/AUG	MAR/SEP	APR/OCT	MAY/NOV	JUN/DEC
PRECIPITATION						
TOTALS	3.26	2.82	4.37	2.63	3.53	5.42
	4.57	6.47	2.81	3.77	2.52	2.90

STD. DEVIATIONS	2.96	0.95	1.30	1.89	2.64	1.99
	2.29	6.38	1.69	2.69	1.66	1.28
RUNOFF						

TOTALS	0.000	0.000	0.000	0.000	0.000	0.000
	0.000	0.000	0.000	0.000	0.000	0.000
STD. DEVIATIONS	0.000	0.000	0.000	0.000	0.000	0.000
	0.000	0.000	0.000	0.000	0.000	0.000
POTENTIAL EVAPOTRANSPIRATION						

TOTALS	1.892	2.205	3.293	4.787	6.327	6.770
	7.049	5.890	4.466	3.365	2.345	1.543
STD. DEVIATIONS	0.140	0.177	0.179	0.403	0.445	0.263
	0.410	0.413	0.352	0.062	0.182	0.125
ACTUAL EVAPOTRANSPIRATION						

TOTALS	1.193	1.541	2.190	3.180	4.706	4.073
	4.978	3.914	2.729	1.267	0.914	0.791
STD. DEVIATIONS	0.095	0.154	0.276	0.684	1.211	1.405
	1.282	1.455	1.165	0.187	0.268	0.186
LATERAL DRAINAGE COLLECTED FROM LAYER 6						

TOTALS	1.0928	1.5526	1.6927	1.2334	1.4685	1.2365
	1.1259	1.0721	1.9870	1.2699	0.7958	0.6370
STD. DEVIATIONS	1.1282	1.3147	1.5474	1.1600	0.6302	0.3111
	0.1489	0.3620	2.5399	1.3425	0.6131	0.4184
LATERAL DRAINAGE RECIRCULATED FROM LAYER 6 INTO L. 1						

TOTALS	0.0000	0.0000	0.0000	0.0000	0.0000	0.0000
	0.0000	0.0000	0.0000	0.0000	0.0000	0.0000
STD. DEVIATIONS	0.0000	0.0000	0.0000	0.0000	0.0000	0.0000
	0.0000	0.0000	0.0000	0.0000	0.0000	0.0000
PERCOLATION/LEAKAGE THROUGH LAYER 8						

TOTALS	0.0000	0.0000	0.0000	0.0000	0.0000	0.0000
	0.0000	0.0000	0.0000	0.0000	0.0000	0.0000
STD. DEVIATIONS	0.0000	0.0000	0.0000	0.0000	0.0000	0.0000
	0.0000	0.0000	0.0000	0.0000	0.0000	0.0000
PERCOLATION/LEAKAGE THROUGH LAYER 9						

TOTALS	0.0000	0.0000	0.0000	0.0000	0.0000	0.0000
	0.0000	0.0000	0.0000	0.0000	0.0000	0.0000
STD. DEVIATIONS	0.0000	0.0000	0.0000	0.0000	0.0000	0.0000
	0.0000	0.0000	0.0000	0.0000	0.0000	0.0000

 AVERAGES OF MONTHLY AVERAGED DAILY HEADS (INCHES)

DAILY AVERAGE HEAD ON TOP OF LAYER 7

AVERAGES	0.0180	0.0281	0.0278	0.0210	0.0241	0.0210
	0.0185	0.0176	0.0668	0.0209	0.0135	0.0105
STD. DEVIATIONS	0.0185	0.0240	0.0254	0.0197	0.0104	0.0053
	0.0024	0.0060	0.1169	0.0221	0.0104	0.0069

AVERAGE ANNUAL TOTALS & (STD. DEVIATIONS) FOR YEARS 1 THROUGH 5

	INCHES		CU. FEET	PERCENT
	-----	-----	-----	-----
PRECIPITATION	45.08	(10.212)	163625.9	100.00
RUNOFF	0.000	(0.0000)	0.00	0.000
POTENTIAL EVAPOTRANSPIRATION	49.932	(0.3704)	181254.19	
ACTUAL EVAPOTRANSPIRATION	31.475	(1.0157)	114254.23	69.827
LATERAL DRAINAGE COLLECTED FROM LAYER 6	15.16420	(9.00105)	55046.047	33.64141
DRAINAGE RECIRCULATED FROM LAYER 6 INTO L. 1	0.00000	(0.00000)	0.000	0.00000
PERCOLATION/LEAKAGE THROUGH LAYER 8	0.00000	(0.00000)	0.013	0.00001
AVERAGE HEAD ON TOP OF LAYER 7	0.024	(0.019)		
PERCOLATION/LEAKAGE THROUGH LAYER 9	0.00000	(0.00000)	0.013	0.00001
CHANGE IN WATER STORAGE	-1.563	(4.5452)	-5674.41	-3.468

```

*****
*****
**
**
**          HYDROLOGIC EVALUATION OF LANDFILL PERFORMANCE          **
**
**          HELP Version 3.95 D          (10 August 2012)          **
**                    developed at          **
** Institute of Soil Science, University of Hamburg, Germany      **
**                    based on          **
**          US HELP MODEL VERSION 3.07 (1 NOVEMBER 1997)        **
**          DEVELOPED BY ENVIRONMENTAL LABORATORY                **
**          USAE WATERWAYS EXPERIMENT STATION                   **
**          FOR USEPA RISK REDUCTION ENGINEERING LABORATORY      **
**
**
*****
*****

```

TIME: 5.14 DATE: 7.03.2015

```

PRECIPITATION DATA FILE: C:\Users\sfutrell\Desktop\Sanford Reruns\After 4
Reruns\SF Charah Sanford 25 yr storm y3m8d16.d4
TEMPERATURE DATA FILE: C:\Users\sfutrell\Desktop\Sanford Reruns\After 4
Reruns\Charah Sanford.d7
SOLAR RADIATION DATA FILE: C:\Users\sfutrell\Desktop\Sanford Reruns\After 4
Reruns\Charah Sanford.d13
EVAPOTRANSPIRATION DATA F. 1: C:\Users\sfutrell\Desktop\Sanford Reruns\After 4
Reruns\Charah Sanford.d11
SOIL AND DESIGN DATA FILE 1: C:\Users\sfutrell\Desktop\Sanford Reruns\After 4
Reruns\Actual Runs\SF Colon 10-2ft lifts no runoff.d10
OUTPUT DATA FILE: C:\Users\sfutrell\Desktop\Sanford Reruns\After 4
Reruns\Actual Runs\Scenario 2 Actual.out

```

```

*****
TITLE: Coal Ash-Second Set of Lifts (Ten 2-foot Lifts, No Runoff)
*****

```

WEATHER DATA SOURCES

NOTE: PRECIPITATION DATA FOR RALEIGH NORTH CAROLINA
WAS ENTERED BY THE USER.

NOTE: TEMPERATURE DATA WAS SYNTHETICALLY GENERATED USING
COEFFICIENTS FOR RALEIGH NORTH CAROLINA

NORMAL MEAN MONTHLY TEMPERATURE (DEGREES FAHRENHEIT)

JAN/JUL	FEB/AUG	MAR/SEP	APR/OCT	MAY/NOV	JUN/DEC
39.60	41.60	49.30	59.50	67.20	73.90
77.70	77.00	71.00	59.70	50.00	42.00

NOTE: SOLAR RADIATION DATA WAS SYNTHETICALLY GENERATED USING
 COEFFICIENTS FOR RALEIGH NORTH CAROLINA
 AND STATION LATITUDE = 35.87 DEGREES

LAYER DATA 1

VALID FOR 5 YEARS

NOTE: INITIAL MOISTURE CONTENT OF THE LAYERS AND SNOW WATER
 WERE SPECIFIED BY THE USER.

LAYER 1

 TYPE 1 - VERTICAL PERCOLATION LAYER
 MATERIAL TEXTURE NUMBER 0
 THICKNESS = 24.00 INCHES
 POROSITY = 0.5410 VOL/VOL
 FIELD CAPACITY = 0.1870 VOL/VOL
 WILTING POINT = 0.0470 VOL/VOL
 INITIAL SOIL WATER CONTENT = 0.3100 VOL/VOL
 EFFECTIVE SAT. HYD. CONDUCT.= 0.1600E-03 CM/SEC

LAYER 2

 TYPE 1 - VERTICAL PERCOLATION LAYER
 MATERIAL TEXTURE NUMBER 0
 THICKNESS = 24.00 INCHES
 POROSITY = 0.5410 VOL/VOL
 FIELD CAPACITY = 0.1870 VOL/VOL
 WILTING POINT = 0.0470 VOL/VOL
 INITIAL SOIL WATER CONTENT = 0.3100 VOL/VOL
 EFFECTIVE SAT. HYD. CONDUCT.= 0.1600E-03 CM/SEC

LAYER 3

 TYPE 1 - VERTICAL PERCOLATION LAYER
 MATERIAL TEXTURE NUMBER 0
 THICKNESS = 24.00 INCHES

POROSITY = 0.5410 VOL/VOL
 FIELD CAPACITY = 0.1870 VOL/VOL
 WILTING POINT = 0.0470 VOL/VOL
 INITIAL SOIL WATER CONTENT = 0.3100 VOL/VOL
 EFFECTIVE SAT. HYD. CONDUCT.= 0.1600E-03 CM/SEC

LAYER 4

TYPE 1 - VERTICAL PERCOLATION LAYER

MATERIAL TEXTURE NUMBER 0

THICKNESS = 24.00 INCHES
 POROSITY = 0.5410 VOL/VOL
 FIELD CAPACITY = 0.1870 VOL/VOL
 WILTING POINT = 0.0470 VOL/VOL
 INITIAL SOIL WATER CONTENT = 0.3100 VOL/VOL
 EFFECTIVE SAT. HYD. CONDUCT.= 0.1600E-03 CM/SEC

LAYER 5

TYPE 1 - VERTICAL PERCOLATION LAYER

MATERIAL TEXTURE NUMBER 0

THICKNESS = 24.00 INCHES
 POROSITY = 0.5410 VOL/VOL
 FIELD CAPACITY = 0.1870 VOL/VOL
 WILTING POINT = 0.0470 VOL/VOL
 INITIAL SOIL WATER CONTENT = 0.3100 VOL/VOL
 EFFECTIVE SAT. HYD. CONDUCT.= 0.1600E-03 CM/SEC

LAYER 6

TYPE 1 - VERTICAL PERCOLATION LAYER

MATERIAL TEXTURE NUMBER 0

THICKNESS = 24.00 INCHES
 POROSITY = 0.5410 VOL/VOL
 FIELD CAPACITY = 0.1870 VOL/VOL
 WILTING POINT = 0.0470 VOL/VOL
 INITIAL SOIL WATER CONTENT = 0.3100 VOL/VOL
 EFFECTIVE SAT. HYD. CONDUCT.= 0.1600E-03 CM/SEC

LAYER 7

TYPE 1 - VERTICAL PERCOLATION LAYER

MATERIAL TEXTURE NUMBER 0

THICKNESS = 24.00 INCHES
 POROSITY = 0.5410 VOL/VOL
 FIELD CAPACITY = 0.1870 VOL/VOL
 WILTING POINT = 0.0470 VOL/VOL
 INITIAL SOIL WATER CONTENT = 0.3100 VOL/VOL

EFFECTIVE SAT. HYD. CONDUCT.= 0.1600E-03 CM/SEC

LAYER 8

TYPE 1 - VERTICAL PERCOLATION LAYER

MATERIAL TEXTURE NUMBER 0

THICKNESS = 24.00 INCHES
 POROSITY = 0.5410 VOL/VOL
 FIELD CAPACITY = 0.1870 VOL/VOL
 WILTING POINT = 0.0470 VOL/VOL
 INITIAL SOIL WATER CONTENT = 0.3100 VOL/VOL
 EFFECTIVE SAT. HYD. CONDUCT.= 0.1600E-03 CM/SEC

LAYER 9

TYPE 1 - VERTICAL PERCOLATION LAYER

MATERIAL TEXTURE NUMBER 0

THICKNESS = 24.00 INCHES
 POROSITY = 0.5410 VOL/VOL
 FIELD CAPACITY = 0.1870 VOL/VOL
 WILTING POINT = 0.0470 VOL/VOL
 INITIAL SOIL WATER CONTENT = 0.3100 VOL/VOL
 EFFECTIVE SAT. HYD. CONDUCT.= 0.1600E-03 CM/SEC

LAYER 10

TYPE 1 - VERTICAL PERCOLATION LAYER

MATERIAL TEXTURE NUMBER 0

THICKNESS = 24.00 INCHES
 POROSITY = 0.5410 VOL/VOL
 FIELD CAPACITY = 0.1870 VOL/VOL
 WILTING POINT = 0.0470 VOL/VOL
 INITIAL SOIL WATER CONTENT = 0.3100 VOL/VOL
 EFFECTIVE SAT. HYD. CONDUCT.= 0.1600E-03 CM/SEC

LAYER 11

TYPE 2 - LATERAL DRAINAGE LAYER

MATERIAL TEXTURE NUMBER 0

THICKNESS = 0.26 INCHES
 POROSITY = 0.8500 VOL/VOL
 FIELD CAPACITY = 0.0100 VOL/VOL
 WILTING POINT = 0.0050 VOL/VOL
 INITIAL SOIL WATER CONTENT = 0.0100 VOL/VOL
 EFFECTIVE SAT. HYD. CONDUCT.= 9.700 CM/SEC
 SLOPE = 2.00 PERCENT
 DRAINAGE LENGTH = 950.0 FEET

LAYER 12

TYPE 4 - FLEXIBLE MEMBRANE LINER

MATERIAL TEXTURE NUMBER 35

THICKNESS = 0.06 INCHES
 EFFECTIVE SAT. HYD. CONDUCT.= 0.2000E-12 CM/SEC
 FML PINHOLE DENSITY = 1.00 HOLES/ACRE
 FML INSTALLATION DEFECTS = 1.00 HOLES/ACRE
 FML PLACEMENT QUALITY = 3 - GOOD

LAYER 13

TYPE 3 - BARRIER SOIL LINER

MATERIAL TEXTURE NUMBER 17

THICKNESS = 0.25 INCHES
 POROSITY = 0.7500 VOL/VOL
 FIELD CAPACITY = 0.7470 VOL/VOL
 WILTING POINT = 0.4000 VOL/VOL
 INITIAL SOIL WATER CONTENT = 0.7500 VOL/VOL
 EFFECTIVE SAT. HYD. CONDUCT.= 0.3000E-08 CM/SEC

LAYER 14

TYPE 1 - VERTICAL PERCOLATION LAYER

MATERIAL TEXTURE NUMBER 16

THICKNESS = 18.00 INCHES
 POROSITY = 0.4270 VOL/VOL
 FIELD CAPACITY = 0.4180 VOL/VOL
 WILTING POINT = 0.3670 VOL/VOL
 INITIAL SOIL WATER CONTENT = 0.4180 VOL/VOL
 EFFECTIVE SAT. HYD. CONDUCT.= 0.1000E-06 CM/SEC

GENERAL DESIGN AND EVAPORATIVE ZONE DATA 1

VALID FOR 5 YEARS

NOTE: SCS RUNOFF CURVE NUMBER WAS COMPUTED FROM DEFAULT SOIL DATA BASE USING SOIL TEXTURE # 9 WITH BARE GROUND CONDITIONS, A SURFACE SLOPE OF 2.% AND A SLOPE LENGTH OF 1000. FEET.

SCS RUNOFF CURVE NUMBER = 91.21
 FRACTION OF AREA ALLOWING RUNOFF = 0.0 PERCENT
 AREA PROJECTED ON HORIZONTAL PLANE = 1.000 ACRES
 EVAPORATIVE ZONE DEPTH = 18.0 INCHES

INITIAL WATER IN EVAPORATIVE ZONE = 5.580 INCHES
 UPPER LIMIT OF EVAPORATIVE STORAGE = 9.738 INCHES
 FIELD CAPACITY OF EVAPORATIVE ZONE = 3.366 INCHES
 LOWER LIMIT OF EVAPORATIVE STORAGE = 0.846 INCHES
 SOIL EVAPORATION ZONE DEPTH = 18.000 INCHES
 INITIAL SNOW WATER = 0.000 INCHES
 INITIAL INTERCEPTION WATER = 0.000 INCHES
 INITIAL WATER IN LAYER MATERIALS = 82.114 INCHES
 TOTAL INITIAL WATER = 82.114 INCHES
 TOTAL SUBSURFACE INFLOW = 0.00 INCHES/YEAR

EVAPOTRANSPIRATION DATA 1

VALID FOR 5 YEARS

NOTE: EVAPOTRANSPIRATION DATA WAS OBTAINED FROM
 RALEIGH NORTH CAROLINA

STATION LATITUDE = 35.87 DEGREES
 MAXIMUM LEAF AREA INDEX = 4.50
 START OF GROWING SEASON (JULIAN DATE) = 86
 END OF GROWING SEASON (JULIAN DATE) = 310
 EVAPORATIVE ZONE DEPTH = 18.0 INCHES
 AVERAGE ANNUAL WIND SPEED = 7.70 MPH
 AVERAGE 1ST QUARTER RELATIVE HUMIDITY = 66.0 %
 AVERAGE 2ND QUARTER RELATIVE HUMIDITY = 70.0 %
 AVERAGE 3RD QUARTER RELATIVE HUMIDITY = 78.0 %
 AVERAGE 4TH QUARTER RELATIVE HUMIDITY = 72.0 %

FINAL WATER STORAGE AT END OF YEAR 5

LAYER	(INCHES)	(VOL/VOL)
1	7.0193	0.2925
2	6.3803	0.2658
3	4.8629	0.2026
4	5.4737	0.2281
5	5.6427	0.2351
6	5.7991	0.2416
7	5.9906	0.2496

8	6.1845	0.2577
9	6.2898	0.2621
10	6.3880	0.2662
11	0.0274	0.1070
12	0.0000	0.0000
13	0.1875	0.7500
14	7.5240	0.4180
TOTAL WATER IN LAYERS	67.770	
SNOW WATER	0.000	
INTERCEPTION WATER	0.000	
TOTAL FINAL WATER	67.770	

PEAK DAILY VALUES FOR YEARS 1 THROUGH 5

	(INCHES)	(CU. FT.)
	-----	-----
PRECIPITATION	6.28	22796.400
RUNOFF	0.000	0.0000
DRAINAGE COLLECTED FROM LAYER 11	0.20818	755.70551
PERCOLATION/LEAKAGE THROUGH LAYER 13	0.000000	0.00013
AVERAGE HEAD ON TOP OF LAYER 12	0.180	
MAXIMUM HEAD ON TOP OF LAYER 12	0.357	
LOCATION OF MAXIMUM HEAD IN LAYER 11 (DISTANCE FROM DRAIN)	6.8 FEET	
PERCOLATION/LEAKAGE THROUGH LAYER 14	0.000000	0.00013
SNOW WATER	1.67	6061.1177
MAXIMUM VEG. SOIL WATER (VOL/VOL)		0.5112
MINIMUM VEG. SOIL WATER (VOL/VOL)		0.0470

*** Maximum heads are computed using McEnroe's equations. ***

Reference: Maximum Saturated Depth over Landfill Liner
 by Bruce M. McEnroe, University of Kansas
 ASCE Journal of Environmental Engineering
 Vol. 119, No. 2, March 1993, pp. 262-270.

AVERAGE MONTHLY VALUES IN INCHES FOR YEARS 1 THROUGH 5

	JAN/JUL	FEB/AUG	MAR/SEP	APR/OCT	MAY/NOV	JUN/DEC
	-----	-----	-----	-----	-----	-----
PRECIPITATION						

TOTALS	3.26 4.57	2.82 6.47	4.37 2.81	2.63 3.77	3.53 2.52	5.42 2.90
STD. DEVIATIONS	2.96 2.29	0.95 6.38	1.30 1.69	1.89 2.69	2.64 1.66	1.99 1.28
RUNOFF						

TOTALS	0.000 0.000	0.000 0.000	0.000 0.000	0.000 0.000	0.000 0.000	0.000 0.000
STD. DEVIATIONS	0.000 0.000	0.000 0.000	0.000 0.000	0.000 0.000	0.000 0.000	0.000 0.000
POTENTIAL EVAPOTRANSPIRATION						

TOTALS	1.892 7.049	2.205 5.890	3.293 4.466	4.787 3.365	6.327 2.345	6.770 1.543
STD. DEVIATIONS	0.140 0.410	0.177 0.413	0.179 0.352	0.403 0.062	0.445 0.182	0.263 0.125
ACTUAL EVAPOTRANSPIRATION						

TOTALS	1.193 4.978	1.541 3.914	2.190 2.729	3.180 1.267	4.706 0.914	4.073 0.791
STD. DEVIATIONS	0.095 1.282	0.154 1.455	0.276 1.165	0.684 0.187	1.211 0.268	1.405 0.186
LATERAL DRAINAGE COLLECTED FROM LAYER 11						

TOTALS	1.5868 1.2174	1.3126 1.0987	1.4316 1.0178	1.3161 1.4159	1.6209 1.6002	1.4440 1.4077
STD. DEVIATIONS	0.9632 0.7112	0.9105 0.6882	1.0646 0.4925	0.9410 1.0880	1.1035 1.5254	1.1316 0.8678
LATERAL DRAINAGE RECIRCULATED FROM LAYER 11 INTO L. 1						

TOTALS	0.0000	0.0000	0.0000	0.0000	0.0000	0.0000

0.0000 0.0000 0.0000 0.0000 0.0000 0.0000

STD. DEVIATIONS 0.0000 0.0000 0.0000 0.0000 0.0000 0.0000
 0.0000 0.0000 0.0000 0.0000 0.0000 0.0000

PERCOLATION/LEAKAGE THROUGH LAYER 13

TOTALS 0.0000 0.0000 0.0000 0.0000 0.0000 0.0000
 0.0000 0.0000 0.0000 0.0000 0.0000 0.0000

STD. DEVIATIONS 0.0000 0.0000 0.0000 0.0000 0.0000 0.0000
 0.0000 0.0000 0.0000 0.0000 0.0000 0.0000

PERCOLATION/LEAKAGE THROUGH LAYER 14

TOTALS 0.0000 0.0000 0.0000 0.0000 0.0000 0.0000
 0.0000 0.0000 0.0000 0.0000 0.0000 0.0000

STD. DEVIATIONS 0.0000 0.0000 0.0000 0.0000 0.0000 0.0000
 0.0000 0.0000 0.0000 0.0000 0.0000 0.0000

AVERAGES OF MONTHLY AVERAGED DAILY HEADS (INCHES)

DAILY AVERAGE HEAD ON TOP OF LAYER 12

AVERAGES 0.0442 0.0402 0.0399 0.0379 0.0452 0.0416
 0.0339 0.0306 0.0293 0.0395 0.0461 0.0392

STD. DEVIATIONS 0.0268 0.0280 0.0297 0.0271 0.0308 0.0326
 0.0198 0.0192 0.0142 0.0303 0.0439 0.0242

AVERAGE ANNUAL TOTALS & (STD. DEVIATIONS) FOR YEARS 1 THROUGH 5

	INCHES		CU. FEET	PERCENT
PRECIPITATION	45.08	(10.212)	163625.9	100.00
RUNOFF	0.000	(0.0000)	0.00	0.000
POTENTIAL EVAPOTRANSPIRATION	49.932	(0.3704)	181254.19	
ACTUAL EVAPOTRANSPIRATION	31.475	(1.0157)	114254.23	69.827
LATERAL DRAINAGE COLLECTED FROM LAYER 11	16.46985	(8.58991)	59785.562	36.53797
DRAINAGE RECIRCULATED FROM LAYER 11 INTO L. 1	0.00000	(0.00000)	0.000	0.00000

PERCOLATION/LEAKAGE THROUGH LAYER 13	0.00000 (0.00000)	0.015	0.00001
AVERAGE HEAD ON TOP OF LAYER 12	0.039 (0.020)		
PERCOLATION/LEAKAGE THROUGH LAYER 14	0.00000 (0.00000)	0.015	0.00001
CHANGE IN WATER STORAGE	-2.869 (8.7784)	-10413.91	-6.364

```

*****
*****
**
**
**          HYDROLOGIC EVALUATION OF LANDFILL PERFORMANCE          **
**
**          HELP Version 3.95 D          (10 August 2012)          **
**                    developed at          **
** Institute of Soil Science, University of Hamburg, Germany      **
**                    based on          **
**          US HELP MODEL VERSION 3.07 (1 NOVEMBER 1997)          **
**          DEVELOPED BY ENVIRONMENTAL LABORATORY          **
**          USAE WATERWAYS EXPERIMENT STATION          **
**          FOR USEPA RISK REDUCTION ENGINEERING LABORATORY          **
**
**
*****
*****

```

TIME: 6.00 DATE: 7.03.2015

```

PRECIPITATION DATA FILE: C:\Users\sfuturell\Desktop\Sanford Reruns\After 4
Reruns\SF Charah Sanford 25 yr storm y3m8d16.d4
TEMPERATURE DATA FILE: C:\Users\sfuturell\Desktop\Sanford Reruns\After 4
Reruns\Charah Sanford.d7
SOLAR RADIATION DATA FILE: C:\Users\sfuturell\Desktop\Sanford Reruns\After 4
Reruns\Charah Sanford.d13
EVAPOTRANSPIRATION DATA F. 1: C:\Users\sfuturell\Desktop\Sanford Reruns\After 4
Reruns\Charah Sanford.d11
SOIL AND DESIGN DATA FILE 1: C:\Users\sfuturell\Desktop\Sanford Reruns\After 4
Reruns\Actual Runs\SF Charh Colon-second lift.d10
OUTPUT DATA FILE: C:\Users\sfuturell\Desktop\Sanford Reruns\After 4
Reruns\Actual Runs\Scenario 3 (old 2) Actual.out

```

```

*****
TITLE: Charah Colon - Two 20-foot Lifts
*****

```

WEATHER DATA SOURCES

NOTE: PRECIPITATION DATA FOR RALEIGH NORTH CAROLINA
WAS ENTERED BY THE USER.

NOTE: TEMPERATURE DATA WAS SYNTHETICALLY GENERATED USING
COEFFICIENTS FOR RALEIGH NORTH CAROLINA

NORMAL MEAN MONTHLY TEMPERATURE (DEGREES FAHRENHEIT)

JAN/JUL	FEB/AUG	MAR/SEP	APR/OCT	MAY/NOV	JUN/DEC
39.60	41.60	49.30	59.50	67.20	73.90
77.70	77.00	71.00	59.70	50.00	42.00

NOTE: SOLAR RADIATION DATA WAS SYNTHETICALLY GENERATED USING
 COEFFICIENTS FOR RALEIGH NORTH CAROLINA
 AND STATION LATITUDE = 35.87 DEGREES

LAYER DATA 1

VALID FOR 5 YEARS

NOTE: INITIAL MOISTURE CONTENT OF THE LAYERS AND SNOW WATER
 WERE SPECIFIED BY THE USER.

LAYER 1

 TYPE 1 - VERTICAL PERCOLATION LAYER
 MATERIAL TEXTURE NUMBER 0
 THICKNESS = 240.00 INCHES
 POROSITY = 0.5410 VOL/VOL
 FIELD CAPACITY = 0.1870 VOL/VOL
 WILTING POINT = 0.0470 VOL/VOL
 INITIAL SOIL WATER CONTENT = 0.3100 VOL/VOL
 EFFECTIVE SAT. HYD. CONDUCT.= 0.1600E-03 CM/SEC

LAYER 2

 TYPE 1 - VERTICAL PERCOLATION LAYER
 MATERIAL TEXTURE NUMBER 0
 THICKNESS = 240.00 INCHES
 POROSITY = 0.5410 VOL/VOL
 FIELD CAPACITY = 0.1870 VOL/VOL
 WILTING POINT = 0.0470 VOL/VOL
 INITIAL SOIL WATER CONTENT = 0.3100 VOL/VOL
 EFFECTIVE SAT. HYD. CONDUCT.= 0.1600E-03 CM/SEC

LAYER 3

 TYPE 2 - LATERAL DRAINAGE LAYER
 MATERIAL TEXTURE NUMBER 0
 THICKNESS = 0.26 INCHES

Scenario 6 - Two 20-foot Lifts; No Runoff; 2% Slope

POROSITY	=	0.8500	VOL/VOL
FIELD CAPACITY	=	0.0100	VOL/VOL
WILTING POINT	=	0.0050	VOL/VOL
INITIAL SOIL WATER CONTENT	=	0.0100	VOL/VOL
EFFECTIVE SAT. HYD. CONDUCT.	=	9.700	CM/SEC
SLOPE	=	2.00	PERCENT
DRAINAGE LENGTH	=	950.0	FEET

LAYER 4

TYPE 4 - FLEXIBLE MEMBRANE LINER

MATERIAL TEXTURE NUMBER 35

THICKNESS	=	0.06	INCHES
EFFECTIVE SAT. HYD. CONDUCT.	=	0.2000E-12	CM/SEC
FML PINHOLE DENSITY	=	1.00	HOLES/ACRE
FML INSTALLATION DEFECTS	=	1.00	HOLES/ACRE
FML PLACEMENT QUALITY	=	3	- GOOD

LAYER 5

TYPE 3 - BARRIER SOIL LINER

MATERIAL TEXTURE NUMBER 17

THICKNESS	=	0.25	INCHES
POROSITY	=	0.7500	VOL/VOL
FIELD CAPACITY	=	0.7470	VOL/VOL
WILTING POINT	=	0.4000	VOL/VOL
INITIAL SOIL WATER CONTENT	=	0.7500	VOL/VOL
EFFECTIVE SAT. HYD. CONDUCT.	=	0.3000E-08	CM/SEC

LAYER 6

TYPE 1 - VERTICAL PERCOLATION LAYER

MATERIAL TEXTURE NUMBER 16

THICKNESS	=	18.00	INCHES
POROSITY	=	0.4270	VOL/VOL
FIELD CAPACITY	=	0.4180	VOL/VOL
WILTING POINT	=	0.3670	VOL/VOL
INITIAL SOIL WATER CONTENT	=	0.4180	VOL/VOL
EFFECTIVE SAT. HYD. CONDUCT.	=	0.1000E-06	CM/SEC

GENERAL DESIGN AND EVAPORATIVE ZONE DATA 1

VALID FOR 5 YEARS

NOTE: SCS RUNOFF CURVE NUMBER WAS COMPUTED FROM DEFAULT

SOIL DATA BASE USING SOIL TEXTURE # 9 WITH BARE
GROUND CONDITIONS, A SURFACE SLOPE OF 2.% AND
A SLOPE LENGTH OF 1000. FEET.

SCS RUNOFF CURVE NUMBER	=	91.21	
FRACTION OF AREA ALLOWING RUNOFF	=	0.0	PERCENT
AREA PROJECTED ON HORIZONTAL PLANE	=	1.000	ACRES
EVAPORATIVE ZONE DEPTH	=	18.0	INCHES
INITIAL WATER IN EVAPORATIVE ZONE	=	5.580	INCHES
UPPER LIMIT OF EVAPORATIVE STORAGE	=	9.738	INCHES
FIELD CAPACITY OF EVAPORATIVE ZONE	=	3.366	INCHES
LOWER LIMIT OF EVAPORATIVE STORAGE	=	0.846	INCHES
SOIL EVAPORATION ZONE DEPTH	=	18.000	INCHES
INITIAL SNOW WATER	=	0.000	INCHES
INITIAL INTERCEPTION WATER	=	0.000	INCHES
INITIAL WATER IN LAYER MATERIALS	=	156.514	INCHES
TOTAL INITIAL WATER	=	156.514	INCHES
TOTAL SUBSURFACE INFLOW	=	0.00	INCHES/YEAR

EVAPOTRANSPIRATION DATA 1

VALID FOR 5 YEARS

NOTE: EVAPOTRANSPIRATION DATA WAS OBTAINED FROM
RALEIGH NORTH CAROLINA

STATION LATITUDE	=	35.87	DEGREES
MAXIMUM LEAF AREA INDEX	=	4.50	
START OF GROWING SEASON (JULIAN DATE)	=	86	
END OF GROWING SEASON (JULIAN DATE)	=	310	
EVAPORATIVE ZONE DEPTH	=	18.0	INCHES
AVERAGE ANNUAL WIND SPEED	=	7.70	MPH
AVERAGE 1ST QUARTER RELATIVE HUMIDITY	=	66.0	%
AVERAGE 2ND QUARTER RELATIVE HUMIDITY	=	70.0	%
AVERAGE 3RD QUARTER RELATIVE HUMIDITY	=	78.0	%
AVERAGE 4TH QUARTER RELATIVE HUMIDITY	=	72.0	%

FINAL WATER STORAGE AT END OF YEAR 5

LAYER	(INCHES)	(VOL/VOL)
----	-----	-----
1	58.8688	0.2453
2	62.4563	0.2602
3	0.0277	0.1081

4	0.0000	0.0000
5	0.1875	0.7500
6	7.5240	0.4180
TOTAL WATER IN LAYERS	129.064	
SNOW WATER	0.000	
INTERCEPTION WATER	0.000	
TOTAL FINAL WATER	129.064	

PEAK DAILY VALUES FOR YEARS 1 THROUGH 5

	(INCHES)	(CU. FT.)
	-----	-----
PRECIPITATION	6.28	22796.400
RUNOFF	0.000	0.0000
DRAINAGE COLLECTED FROM LAYER 3	0.18561	673.77380
PERCOLATION/LEAKAGE THROUGH LAYER 5	0.000000	0.00012
AVERAGE HEAD ON TOP OF LAYER 4	0.160	
MAXIMUM HEAD ON TOP OF LAYER 4	0.317	
LOCATION OF MAXIMUM HEAD IN LAYER 3 (DISTANCE FROM DRAIN)	11.4 FEET	
PERCOLATION/LEAKAGE THROUGH LAYER 6	0.000000	0.00012
SNOW WATER	1.67	6061.1177
MAXIMUM VEG. SOIL WATER (VOL/VOL)		0.5112
MINIMUM VEG. SOIL WATER (VOL/VOL)		0.0470

*** Maximum heads are computed using McEnroe's equations. ***

Reference: Maximum Saturated Depth over Landfill Liner
 by Bruce M. McEnroe, University of Kansas
 ASCE Journal of Environmental Engineering
 Vol. 119, No. 2, March 1993, pp. 262-270.

AVERAGE MONTHLY VALUES IN INCHES FOR YEARS 1 THROUGH 5

	JAN/JUL	FEB/AUG	MAR/SEP	APR/OCT	MAY/NOV	JUN/DEC

PRECIPITATION						

TOTALS	3.26 4.57	2.82 6.47	4.37 2.81	2.63 3.77	3.53 2.52	5.42 2.90
STD. DEVIATIONS	2.96 2.29	0.95 6.38	1.30 1.69	1.89 2.69	2.64 1.66	1.99 1.28
RUNOFF						

TOTALS	0.000 0.000	0.000 0.000	0.000 0.000	0.000 0.000	0.000 0.000	0.000 0.000
STD. DEVIATIONS	0.000 0.000	0.000 0.000	0.000 0.000	0.000 0.000	0.000 0.000	0.000 0.000
POTENTIAL EVAPOTRANSPIRATION						

TOTALS	1.892 7.049	2.205 5.890	3.293 4.466	4.787 3.365	6.327 2.345	6.770 1.543
STD. DEVIATIONS	0.140 0.410	0.177 0.413	0.179 0.352	0.403 0.062	0.445 0.182	0.263 0.125
ACTUAL EVAPOTRANSPIRATION						

TOTALS	1.193 4.978	1.541 3.914	2.190 2.729	3.180 1.267	4.706 0.914	4.073 0.791
STD. DEVIATIONS	0.095 1.282	0.154 1.455	0.276 1.165	0.684 0.187	1.211 0.268	1.405 0.186
LATERAL DRAINAGE COLLECTED FROM LAYER 3						

TOTALS	1.9890 1.6952	1.6404 1.4709	2.2497 1.5327	1.5015 1.1494	1.3223 1.5154	1.2119 1.8126
STD. DEVIATIONS	0.6801 0.7345	0.6694 1.0940	1.2875 1.1075	1.0303 0.8121	1.0225 0.7054	1.0078 0.9298
LATERAL DRAINAGE RECIRCULATED FROM LAYER 3 INTO L. 1						

TOTALS	0.0000 0.0000	0.0000 0.0000	0.0000 0.0000	0.0000 0.0000	0.0000 0.0000	0.0000 0.0000
STD. DEVIATIONS	0.0000 0.0000	0.0000 0.0000	0.0000 0.0000	0.0000 0.0000	0.0000 0.0000	0.0000 0.0000
PERCOLATION/LEAKAGE THROUGH LAYER 5						

TOTALS	0.0000	0.0000	0.0000	0.0000	0.0000	0.0000

Scenario 6 - Two 20-foot Lifts; No Runoff; 2% Slope

	0.0000	0.0000	0.0000	0.0000	0.0000	0.0000
STD. DEVIATIONS	0.0000	0.0000	0.0000	0.0000	0.0000	0.0000
	0.0000	0.0000	0.0000	0.0000	0.0000	0.0000
PERCOLATION/LEAKAGE THROUGH LAYER 6						

TOTALS	0.0000	0.0000	0.0000	0.0000	0.0000	0.0000
	0.0000	0.0000	0.0000	0.0000	0.0000	0.0000
STD. DEVIATIONS	0.0000	0.0000	0.0000	0.0000	0.0000	0.0000
	0.0000	0.0000	0.0000	0.0000	0.0000	0.0000

 AVERAGES OF MONTHLY AVERAGED DAILY HEADS (INCHES)

DAILY AVERAGE HEAD ON TOP OF LAYER 4						

AVERAGES	0.0554	0.0502	0.0627	0.0432	0.0369	0.0349
	0.0473	0.0410	0.0441	0.0320	0.0437	0.0505
STD. DEVIATIONS	0.0190	0.0203	0.0359	0.0297	0.0285	0.0290
	0.0205	0.0305	0.0319	0.0226	0.0203	0.0259

AVERAGE ANNUAL TOTALS & (STD. DEVIATIONS) FOR YEARS 1 THROUGH 5

	INCHES		CU. FEET	PERCENT
	-----	-----	-----	-----
PRECIPITATION	45.08	(10.212)	163625.9	100.00
RUNOFF	0.000	(0.0000)	0.00	0.000
POTENTIAL EVAPOTRANSPIRATION	49.932	(0.3704)	181254.19	
ACTUAL EVAPOTRANSPIRATION	31.475	(1.0157)	114254.23	69.827
LATERAL DRAINAGE COLLECTED FROM LAYER 3	19.09096	(8.58853)	69300.180	42.35283
DRAINAGE RECIRCULATED FROM LAYER 3 INTO L. 1	0.00000	(0.00000)	0.000	0.00000
PERCOLATION/LEAKAGE THROUGH LAYER 5	0.00000	(0.00000)	0.015	0.00001
AVERAGE HEAD ON TOP OF LAYER 4	0.045	(0.020)		
PERCOLATION/LEAKAGE THROUGH LAYER 6	0.00000	(0.00000)	0.015	0.00001

CHANGE IN WATER STORAGE -5.490 (15.0323) -19928.54 -12.179

```

*****
*****
**
**
**          HYDROLOGIC EVALUATION OF LANDFILL PERFORMANCE          **
**
**          HELP Version 3.95 D          (10 August 2012)          **
**                    developed at          **
** Institute of Soil Science, University of Hamburg, Germany      **
**                    based on          **
**          US HELP MODEL VERSION 3.07 (1 NOVEMBER 1997)          **
**                    DEVELOPED BY ENVIRONMENTAL LABORATORY        **
**                    USAE WATERWAYS EXPERIMENT STATION          **
**          FOR USEPA RISK REDUCTION ENGINEERING LABORATORY        **
**
**
*****
*****

```

TIME: 6.12 DATE: 7.03.2015

```

PRECIPITATION DATA FILE: C:\Users\sfutrell\Desktop\Sanford Reruns\After 4
Reruns\SF Charah Sanford 25 yr storm y3m8d16.d4
TEMPERATURE DATA FILE: C:\Users\sfutrell\Desktop\Sanford Reruns\After 4
Reruns\Charah Sanford.d7
SOLAR RADIATION DATA FILE: C:\Users\sfutrell\Desktop\Sanford Reruns\After 4
Reruns\Charah Sanford.d13
EVAPOTRANSPIRATION DATA F. 1: C:\Users\sfutrell\Desktop\Sanford Reruns\After 4
Reruns\Charah Sanford.d11
SOIL AND DESIGN DATA FILE 1: C:\Users\sfutrell\Desktop\Sanford Reruns\After 4
Reruns\Actual Runs\SF Charah Colon-third lift.d10
OUTPUT DATA FILE: C:\Users\sfutrell\Desktop\Sanford Reruns\After 4
Reruns\Actual Runs\Scenario 4 (old 3) Actual.out

```

```

*****
TITLE: Charah Colon- Three 20-ft Lifts
*****

```

WEATHER DATA SOURCES

NOTE: PRECIPITATION DATA FOR RALEIGH NORTH CAROLINA
WAS ENTERED BY THE USER.

NOTE: TEMPERATURE DATA WAS SYNTHETICALLY GENERATED USING
COEFFICIENTS FOR RALEIGH NORTH CAROLINA

NORMAL MEAN MONTHLY TEMPERATURE (DEGREES FAHRENHEIT)

JAN/JUL	FEB/AUG	MAR/SEP	APR/OCT	MAY/NOV	JUN/DEC
39.60	41.60	49.30	59.50	67.20	73.90
77.70	77.00	71.00	59.70	50.00	42.00

NOTE: SOLAR RADIATION DATA WAS SYNTHETICALLY GENERATED USING
 COEFFICIENTS FOR RALEIGH NORTH CAROLINA
 AND STATION LATITUDE = 35.87 DEGREES

LAYER DATA 1

VALID FOR 5 YEARS

NOTE: INITIAL MOISTURE CONTENT OF THE LAYERS AND SNOW WATER
 WERE SPECIFIED BY THE USER.

LAYER 1

 TYPE 1 - VERTICAL PERCOLATION LAYER
 MATERIAL TEXTURE NUMBER 0
 THICKNESS = 240.00 INCHES
 POROSITY = 0.5410 VOL/VOL
 FIELD CAPACITY = 0.1870 VOL/VOL
 WILTING POINT = 0.0470 VOL/VOL
 INITIAL SOIL WATER CONTENT = 0.3100 VOL/VOL
 EFFECTIVE SAT. HYD. CONDUCT.= 0.1600E-03 CM/SEC

LAYER 2

 TYPE 1 - VERTICAL PERCOLATION LAYER
 MATERIAL TEXTURE NUMBER 0
 THICKNESS = 240.00 INCHES
 POROSITY = 0.5410 VOL/VOL
 FIELD CAPACITY = 0.1870 VOL/VOL
 WILTING POINT = 0.0470 VOL/VOL
 INITIAL SOIL WATER CONTENT = 0.3100 VOL/VOL
 EFFECTIVE SAT. HYD. CONDUCT.= 0.1600E-03 CM/SEC

LAYER 3

 TYPE 1 - VERTICAL PERCOLATION LAYER
 MATERIAL TEXTURE NUMBER 0
 THICKNESS = 240.00 INCHES

POROSITY = 0.5410 VOL/VOL
 FIELD CAPACITY = 0.1870 VOL/VOL
 WILTING POINT = 0.0470 VOL/VOL
 INITIAL SOIL WATER CONTENT = 0.3100 VOL/VOL
 EFFECTIVE SAT. HYD. CONDUCT.= 0.1600E-03 CM/SEC

LAYER 4

TYPE 2 - LATERAL DRAINAGE LAYER

MATERIAL TEXTURE NUMBER 0

THICKNESS = 0.26 INCHES
 POROSITY = 0.8500 VOL/VOL
 FIELD CAPACITY = 0.0100 VOL/VOL
 WILTING POINT = 0.0050 VOL/VOL
 INITIAL SOIL WATER CONTENT = 0.0100 VOL/VOL
 EFFECTIVE SAT. HYD. CONDUCT.= 9.700 CM/SEC
 SLOPE = 2.00 PERCENT
 DRAINAGE LENGTH = 950.0 FEET

LAYER 5

TYPE 4 - FLEXIBLE MEMBRANE LINER

MATERIAL TEXTURE NUMBER 35

THICKNESS = 0.06 INCHES
 EFFECTIVE SAT. HYD. CONDUCT.= 0.2000E-12 CM/SEC
 FML PINHOLE DENSITY = 1.00 HOLES/ACRE
 FML INSTALLATION DEFECTS = 1.00 HOLES/ACRE
 FML PLACEMENT QUALITY = 3 - GOOD

LAYER 6

TYPE 3 - BARRIER SOIL LINER

MATERIAL TEXTURE NUMBER 17

THICKNESS = 0.25 INCHES
 POROSITY = 0.7500 VOL/VOL
 FIELD CAPACITY = 0.7470 VOL/VOL
 WILTING POINT = 0.4000 VOL/VOL
 INITIAL SOIL WATER CONTENT = 0.7500 VOL/VOL
 EFFECTIVE SAT. HYD. CONDUCT.= 0.3000E-08 CM/SEC

LAYER 7

TYPE 1 - VERTICAL PERCOLATION LAYER

MATERIAL TEXTURE NUMBER 16

THICKNESS = 18.00 INCHES
 POROSITY = 0.4270 VOL/VOL
 FIELD CAPACITY = 0.4180 VOL/VOL
 WILTING POINT = 0.3670 VOL/VOL

INITIAL SOIL WATER CONTENT = 0.4180 VOL/VOL
 EFFECTIVE SAT. HYD. CONDUCT.= 0.1000E-06 CM/SEC

GENERAL DESIGN AND EVAPORATIVE ZONE DATA 1

VALID FOR 5 YEARS

NOTE: SCS RUNOFF CURVE NUMBER WAS COMPUTED FROM DEFAULT
 SOIL DATA BASE USING SOIL TEXTURE # 9 WITH BARE
 GROUND CONDITIONS, A SURFACE SLOPE OF 2.% AND
 A SLOPE LENGTH OF 1000. FEET.

SCS RUNOFF CURVE NUMBER	=	91.21	
FRACTION OF AREA ALLOWING RUNOFF	=	0.0	PERCENT
AREA PROJECTED ON HORIZONTAL PLANE	=	1.000	ACRES
EVAPORATIVE ZONE DEPTH	=	18.0	INCHES
INITIAL WATER IN EVAPORATIVE ZONE	=	5.580	INCHES
UPPER LIMIT OF EVAPORATIVE STORAGE	=	9.738	INCHES
FIELD CAPACITY OF EVAPORATIVE ZONE	=	3.366	INCHES
LOWER LIMIT OF EVAPORATIVE STORAGE	=	0.846	INCHES
SOIL EVAPORATION ZONE DEPTH	=	18.000	INCHES
INITIAL SNOW WATER	=	0.000	INCHES
INITIAL INTERCEPTION WATER	=	0.000	INCHES
INITIAL WATER IN LAYER MATERIALS	=	230.914	INCHES
TOTAL INITIAL WATER	=	230.914	INCHES
TOTAL SUBSURFACE INFLOW	=	0.00	INCHES/YEAR

EVAPOTRANSPIRATION DATA 1

VALID FOR 5 YEARS

NOTE: EVAPOTRANSPIRATION DATA WAS OBTAINED FROM
 RALEIGH NORTH CAROLINA

STATION LATITUDE	=	35.87	DEGREES
MAXIMUM LEAF AREA INDEX	=	4.50	
START OF GROWING SEASON (JULIAN DATE)	=	86	
END OF GROWING SEASON (JULIAN DATE)	=	310	
EVAPORATIVE ZONE DEPTH	=	18.0	INCHES
AVERAGE ANNUAL WIND SPEED	=	7.70	MPH
AVERAGE 1ST QUARTER RELATIVE HUMIDITY	=	66.0	%
AVERAGE 2ND QUARTER RELATIVE HUMIDITY	=	70.0	%
AVERAGE 3RD QUARTER RELATIVE HUMIDITY	=	78.0	%
AVERAGE 4TH QUARTER RELATIVE HUMIDITY	=	72.0	%

FINAL WATER STORAGE AT END OF YEAR 5

LAYER	(INCHES)	(VOL/VOL)
----	-----	-----
1	58.8688	0.2453
2	62.4563	0.2602
3	62.2274	0.2593
4	0.0191	0.0744
5	0.0000	0.0000
6	0.1875	0.7500
7	7.5240	0.4180
TOTAL WATER IN LAYERS	191.283	
SNOW WATER	0.000	
INTERCEPTION WATER	0.000	
TOTAL FINAL WATER	191.283	

PEAK DAILY VALUES FOR YEARS 1 THROUGH 5

	(INCHES)	(CU. FT.)
	-----	-----
PRECIPITATION	6.28	22796.400
RUNOFF	0.000	0.0000
DRAINAGE COLLECTED FROM LAYER 4	0.15094	547.92310
PERCOLATION/LEAKAGE THROUGH LAYER 6	0.000000	0.00010
AVERAGE HEAD ON TOP OF LAYER 5	0.130	
MAXIMUM HEAD ON TOP OF LAYER 5	0.259	
LOCATION OF MAXIMUM HEAD IN LAYER 4 (DISTANCE FROM DRAIN)	0.0 FEET	
PERCOLATION/LEAKAGE THROUGH LAYER 7	0.000000	0.00010
SNOW WATER	1.67	6061.1177

MAXIMUM VEG. SOIL WATER (VOL/VOL) 0.5112
 MINIMUM VEG. SOIL WATER (VOL/VOL) 0.0470

*** Maximum heads are computed using McEnroe's equations. ***

Reference: Maximum Saturated Depth over Landfill Liner
 by Bruce M. McEnroe, University of Kansas
 ASCE Journal of Environmental Engineering
 Vol. 119, No. 2, March 1993, pp. 262-270.

AVERAGE MONTHLY VALUES IN INCHES FOR YEARS 1 THROUGH 5

	JAN/JUL	FEB/AUG	MAR/SEP	APR/OCT	MAY/NOV	JUN/DEC
	-----	-----	-----	-----	-----	-----
PRECIPITATION						

TOTALS	3.26 4.57	2.82 6.47	4.37 2.81	2.63 3.77	3.53 2.52	5.42 2.90
STD. DEVIATIONS	2.96 2.29	0.95 6.38	1.30 1.69	1.89 2.69	2.64 1.66	1.99 1.28
RUNOFF						

TOTALS	0.000 0.000	0.000 0.000	0.000 0.000	0.000 0.000	0.000 0.000	0.000 0.000
STD. DEVIATIONS	0.000 0.000	0.000 0.000	0.000 0.000	0.000 0.000	0.000 0.000	0.000 0.000
POTENTIAL EVAPOTRANSPIRATION						

TOTALS	1.892 7.049	2.205 5.890	3.293 4.466	4.787 3.365	6.327 2.345	6.770 1.543
STD. DEVIATIONS	0.140 0.410	0.177 0.413	0.179 0.352	0.403 0.062	0.445 0.182	0.263 0.125
ACTUAL EVAPOTRANSPIRATION						

TOTALS	1.193 4.978	1.541 3.914	2.190 2.729	3.180 1.267	4.706 0.914	4.073 0.791
STD. DEVIATIONS	0.095 1.282	0.154 1.455	0.276 1.165	0.684 0.187	1.211 0.268	1.405 0.186
LATERAL DRAINAGE COLLECTED FROM LAYER 4						

TOTALS	1.7299	1.8268	1.7892	2.0809	2.3858	2.0359

Scenario 7 - Three 20-foot Lifts; No Runoff; 2% Slope

	1.8881	1.6389	1.5860	1.5715	1.7124	1.2820
STD. DEVIATIONS	1.0674	0.9114	0.4574	0.8264	0.9691	0.7580
	0.8076	0.9788	0.9477	0.9047	0.7171	0.9394

LATERAL DRAINAGE RECIRCULATED FROM LAYER 4 INTO L. 1

TOTALS	0.0000	0.0000	0.0000	0.0000	0.0000	0.0000
	0.0000	0.0000	0.0000	0.0000	0.0000	0.0000
STD. DEVIATIONS	0.0000	0.0000	0.0000	0.0000	0.0000	0.0000
	0.0000	0.0000	0.0000	0.0000	0.0000	0.0000

PERCOLATION/LEAKAGE THROUGH LAYER 6

TOTALS	0.0000	0.0000	0.0000	0.0000	0.0000	0.0000
	0.0000	0.0000	0.0000	0.0000	0.0000	0.0000
STD. DEVIATIONS	0.0000	0.0000	0.0000	0.0000	0.0000	0.0000
	0.0000	0.0000	0.0000	0.0000	0.0000	0.0000

PERCOLATION/LEAKAGE THROUGH LAYER 7

TOTALS	0.0000	0.0000	0.0000	0.0000	0.0000	0.0000
	0.0000	0.0000	0.0000	0.0000	0.0000	0.0000
STD. DEVIATIONS	0.0000	0.0000	0.0000	0.0000	0.0000	0.0000
	0.0000	0.0000	0.0000	0.0000	0.0000	0.0000

AVERAGES OF MONTHLY AVERAGED DAILY HEADS (INCHES)

DAILY AVERAGE HEAD ON TOP OF LAYER 5

AVERAGES	0.0482	0.0560	0.0499	0.0599	0.0665	0.0586
	0.0526	0.0457	0.0457	0.0438	0.0493	0.0357
STD. DEVIATIONS	0.0298	0.0281	0.0128	0.0238	0.0270	0.0218
	0.0225	0.0273	0.0273	0.0252	0.0207	0.0262

AVERAGE ANNUAL TOTALS & (STD. DEVIATIONS) FOR YEARS 1 THROUGH 5

	INCHES		CU. FEET	PERCENT
PRECIPITATION	45.08	(10.212)	163625.9	100.00
RUNOFF	0.000	(0.0000)	0.00	0.000
POTENTIAL EVAPOTRANSPIRATION	49.932	(0.3704)	181254.19	

Scenario 7 - Three 20-foot Lifts; No Runoff; 2% Slope

ACTUAL EVAPOTRANSPIRATION	31.475	(1.0157)	114254.23	69.827
LATERAL DRAINAGE COLLECTED FROM LAYER 4	21.52720	(9.29538)	78143.742	47.75758
DRAINAGE RECIRCULATED FROM LAYER 4 INTO L. 1	0.00000	(0.00000)	0.000	0.00000
PERCOLATION/LEAKAGE THROUGH LAYER 6	0.00000	(0.00000)	0.016	0.00001
AVERAGE HEAD ON TOP OF LAYER 5	0.051	(0.022)		
PERCOLATION/LEAKAGE THROUGH LAYER 7	0.00000	(0.00000)	0.016	0.00001
CHANGE IN WATER STORAGE	-7.926	(18.5106)	-28772.12	-17.584

Attachment 3

Leachate Collection Geocomposite Hydraulic Conductivity Determination

This page intentionally left blank.

HDR Engineering, Inc.

Job No. _____

No. _____



Project Sanford Mine Bottom Liner

Computed K. Perera

Date 9/30/2014

Task Hydraulic Conductivity and Drainage Layer Capacity

Checked TMY

Date 10/22/14

Problem

Determine the hydraulic conductivity and drainage capacity of the geocomposite drainage layer in the bottom liner system.

Transmissivity Calculations

Bottom liner from bottom to top 18" Compacted soil liner-GCL - 60-mil HDPE - Double-sided Geocomposite - CCP

Determine 100-hour transmissivity (Θ_{100}).

Use GSE 300-mil GSE Coal Drain or equivalent (see attached cut sheet with product specifications).

$$\Theta_{allow} = \frac{\Theta_{100}}{RF_{CR} * RF_{CC} * RF_{BC}}$$

$$\Theta_{allow} = \Theta_{req} \cdot FS_D$$

$$\Theta_{req} = k \cdot b$$

where,

- Θ_{allow} = minimum allowable transmissivity of geocomposite (cm²/s)
- Θ_{req} = required transmissivity for site (cm²/s)
- FS_D = overall factor of safety for drainage
- Θ_{100} = transmissivity after 100 hrs. under expected load (cm²/s)
- RF_{CR} = reduction factor for creep deformation
- RF_{CC} = reduction factor for chemical clogging
- RF_{BC} = reduction factor for biological clogging
- k = saturated hydraulic conductivity (cm/s)
- b = thickness of geonet (cm)

Information based on product data for GSE Coal Drain 300 mil. Site specific testing is recommended before selecting the material for installation to confirm minimum transmissivity.

Parameters	Geocomposite (300-mil) @ 5,000 psf ⁽¹⁾
Slope	0.02
$FS_D^{(2)}$	2.0
$RF_{CR}^{(2)}$	1.06
$RF_{CC}^{(2)}$	1.8
$RF_{BC}^{(2)}$	1.2
Θ_{100} (m ² /s)	0.0033
Θ_{allow} (cm ² /s)	14.82
Θ_{req} (cm ² /s)	7.41
Manufactured Thickness (mils)	300
Manufactured Thickness (cm)	0.76
Design Hydraulic Conductivity (cm/s)	9.7
Retained Final Thickness (mils)	256.5

Notes:

1. psf = pounds per square foot
2. Reduction factors based on HDR experience and information provided by GSE.



October 1, 2014

Kanishka Perera, Ph.D., P.E.
HDR
200 W. Forsyth Street
Jacksonville, Florida 32202

RE: CoalDrain FabriNet Geocomposite Transmissivity (ASTM D 4716) Results
Duke Energy Landfill Cell Construction, North Carolina

Dear Mr. Perera,

As requested, GSE Environmental, LLC has summarized transmissivity test results for 300 mil CoalDrain FabriNet Geocomposite. CoalDrain Geocomposite is specifically designed to minimize clogging, piping and the intrusion of non-cohesive fine-grained material into the landfill leachate collection system. It is a 300 mil thick biplanar geonet structure with an innovative composite fabric to serve as a filter against fine material such as fly ash and gypsum. Testing was conducted in accordance with ASTM D 4716 *Standard Test Method for Determining the (In-plane) Flow Rate per Unit Width and Hydraulic Transmissivity of a Geosynthetic Using a Constant Head*.

Please note that the following Transmissivity test results are based on these boundary conditions: 100-hours at a Gradient of 0.02 using water at 20°C (68°F) between Fly Ash/Geocomposite/Geomembrane boundaries.

Normal Load (psf)	Transmissivity (m ² /s)	Thickness Retained (%)	Creep Reduction Factor
5,000	3.3x10 ⁻³	95	1.06

Thickness Retained and Creep Reduction Factor are based on conventional 10,000-hour geonet creep data. The maximum recommended design load on 300 mil biplanar CoalDrain FabriNet Geocomposite is about 15,000 psf.

Please contact me at (502) 209-0325 should you wish to discuss or have questions.

Respectfully,

Steven M. Mayes, P.E.
Senior Technical Manager, North America

GSE CoalDrain 300 mil Geocomposite (Double-Sided)

GSE CoalDrain geocomposite consists of a 300 mil thick GSE HyperNet geonet heat-laminated with a non-woven geotextile on the bottom side and an innovative composite fabric on the top side. The top geotextile serves as filter against fine materials like coal ash and FGD gypsum while the core serves the drainage function. The innovative geocomposite has been tested extensively in the laboratory and the field and has been proven to meet the performance requirements of an effective filter against coal combustion residuals.



AT THE CORE:
A high flow geocomposite that effectively filters coal combustion residuals.

Product Specifications

Tested Property	Test Method	Frequency	Minimum Average Roll Value ⁽¹⁾
Geocomposite			
Transmissivity ⁽²⁾ , gal/min/ft (m ² /sec)	ASTM D 4716	1/540,000 ft ²	4.35 (9 X 10 ⁻⁴)
Ply Adhesion, lb/in	ASTM D 7005	1/50,000 ft ²	0.5
Geonet Core^(1,3) - GSE HyperNet 300			
Geonet Core Thickness, mil	ASTM D 5199	1/50,000 ft ²	300
Density, g/cm ³	ASTM D 1505	1/50,000 ft ²	0.94
Tensile Strength (MD), lb/in	ASTM D 7179	1/50,000 ft ²	75
Carbon Black Content, %	ASTM D 4218	1/50,000 ft ²	2.0
Compressive Strength, psf	ASTM D 6364	1/540,000 ft ²	25,000
Top Composite Geotextile^(1,3)			
Structure	Hybrid monolithic woven-nonwoven needlepunched		
Mass per Unit Area, oz/yd ²	ASTM D 5261	1/90,000 ft ²	14
Grab Tensile Strength, lb	ASTM D 4632	1/90,000 ft ²	200
Puncture Strength, lb	ASTM D 4833	1/90,000 ft ²	100
Trapezoidal Tear Strength, lb	ASTM D 4533	1/90,000 ft ²	85
AOS, US Sieve (mm)	ASTM D 4751	1/540,000 ft ²	170 (0.088)
Permittivity, (sec ⁻¹)	ASTM D 4491	1/500,000 ft ²	0.3
Water Flow Rate, gpm/ft ²	ASTM D 4491	1/500,000 ft ²	20
UV Resistance, % retained	ASTM D 4355 (after 500 hours)	per formulation	70
Field Basin Tests		per formulation	see note ⁵

[Product specifications continued on back]



AT THE CORE:
A high flow
geocomposite that
effectively filters coal
combustion residuals.

Product Specifications [continued]

Tested Property	Test Method	Frequency	Minimum Average Roll Value ⁽¹⁾
Bottom Geotextile			
Mass per Unit Area, oz/yd ²	ASTM D 5261	1/90,000 ft ²	6
Grab Tensile Strength, lb	ASTM D 4632	1/90,000 ft ²	160
Grab Elongation	ASTM D 4632	1/90,000 ft ²	50%
CBR Puncture Strength, lb	ASTM D 6241	1/90,000 ft ²	435
Trapezoidal Tear Strength, lb	ASTM D 4533	1/90,000 ft ²	65
AOS, US Sieve (mm)	ASTM D 4751	1/540,000 ft ²	70 (0.212)
Permittivity, (sec ⁻¹)	ASTM D 4491	1/540,000 ft ²	1.5
Water Flow Rate, gpm/ft ²	ASTM D 4491	1/540,000 ft ²	110
UV Resistance, % retained	ASTM D 4355 (after 500 hours)	per formulation	70
TYPICAL ROLL DIMENSIONS⁽⁴⁾			
Roll Width, ft			15.0
Roll Length, ft			160
Roll Area, ft ²			2,400

NOTES:

- ⁽¹⁾All geotextile are minimum average roll values except AOS which is maximum average roll value and UV resistance is typical value. Geonet core thickness is nominal value.
- ⁽²⁾Gradient of 0.1, normal load of 10,000 psf, water at 70° F between steel plates for 15 minutes. Contact GSE for performance transmissivity value for use in design.
- ⁽³⁾Component properties prior to lamination.
- ⁽⁴⁾Roll widths and lengths have a tolerance of ±1%.
- ⁽⁵⁾Filter compatibility with a minimum of three types of CCP materials (fly ash, stabilized FGD, and FGD gypsum) under simulated field conditions.

GSE is a leading manufacturer and marketer of geosynthetic lining products and services. We've built a reputation of reliability through our dedication to providing consistency of product, price and protection to our global customers.

Our commitment to innovation, our focus on quality and our industry expertise allow us the flexibility to collaborate with our clients to develop a custom, purpose-fit solution.



[DURABILITY RUNS DEEP] For more information on this product and others, please visit us at GSEworld.com, call 800.435.2008 or contact your local sales office.

Attachment 4

Physical Properties of Ash

This page intentionally left blank.

June 30, 2010

Charah, Inc
307 Townpark Circle
Unit M, Suite 100
Louisville, KY 40243

Attention: Mr. Bobby Raia

Re; Coal Combustion By-product Characterization Testing
Asheville Airport Area 4
Asheville, NC
GeoTrack Project No. 10-2626-N

Ladies and Gentlemen:

GeoTrack Technologies, Inc. has completed characterization testing of an ash sample for the referenced project, and we present the results herein. The work was performed to address several items in the ASTM E 2277-03 Compliance Spread Sheet, as proposed on April 9, 2010, and amended. This letter presents a brief summary of the procedures and presents the testing results.

Project Description and Sampling: The material in question includes coal combustion by-products from the Asheville Steam Electric Power Plant, in Buncombe County, NC. We understand that the combustion by-products include a mixture of fly ash and bottom ash that are collected and discharged to holding ponds on the power plant property. The combined combustion by-products (hereinafter referred to as CCB's) are proposed for use in an engineered fill on the southwest portion of the Asheville Regional Airport property (Asheville Airport Area 4).

GeoTrack visited the power plant on April 12, 2010 and collected a sample the CCB. A grab sample was collected from the second stage pond (the *dry* pond) using procedures in conformance with ASTM C 311 (ASTM D 75) for the physical testing. Additionally, a portion of the sample was sampled and placed in laboratory-prepared containers in accordance with applicable EPA SW846 procedures for the chemical analysis.

The chemical analysis sample was immediately placed on ice, as required, and transported to Prism Laboratories in Charlotte, NC for chemical analyses as described in subsequent sections of this report. The physical test sample was split in accordance with ASTM procedures and subjected to various tests as described in subsequent sections.

Physical Testing: Table 1 presents the physical (engineering) tests performed, the applicable test methods, and the results. Where applicable, individual test reports are attached. Detailed evaluation of the engineering characteristics is beyond the scope of this report, and the suitability

of the various properties is dependent upon final fill usage; however, a few comments are offered based upon our cursory review of the test results.

The grain size characteristics and specific gravity are within expected ranges based on general experience with similar CCB's. The material consists predominantly of silt-sized particles that are essentially cohesionless in nature. The sand content of the sample is most likely influenced by the bottom ash content of this CCB, as a pure fly ash sample would be expected to be more uniformly graded and have a higher silt content.

The Standard Proctor Maximum Dry Density achieved for this sample (70.7 pounds per cubic foot, pcf) was on the low end of the range typically achieved for similar products. The Proctor curve is relatively flat, indicating the material is not sensitive to moisture content. The compaction test results varied significantly from test results obtained by GeoTrack from CCB's placed in Area 1 (which were also variable). These results indicate considerable variability in densities, moisture contents, etc. might be expected, and these properties are most likely influenced by daily plant procedures and handling of the source stockpiles.

The field moisture content of this sample was 28.5 percent, which is 1.6 percent dry of the material's Standard Proctor Maximum Dry Density. This moisture content is within the optimal range recommended for effective compaction. This result indicates moisture adjustment requirements should be minimal, but they will be influenced by prevailing weather and drying that occurs during transportation.

Despite the low compacted dry density, the strength properties of this sample are favorable for most routine engineering applications. The strength properties for both drained (effective or long-term) and undrained (total or short-term loading) conditions are comparable to area soils compacted to equivalent specifications. The effective strength ($\phi=34^\circ$), in particular, is on the high end of the range typically achieved for area soils. Similarly, the consolidation test results indicate settlement characteristics of the CCB's will be comparable, or more favorable (less compressible) than, typical area soils. The hydraulic conductivity is also comparable to naturally-occurring soils in the site area.

Chemical Testing: The attached Tables 2 through 2C present the chemical analyses performed, the applicable test methods, and a summary of the results. For clarity, most compounds not detected are not included in the tables except for comparison between the analytical methods. The complete list of SPLP metals results are shown in Table 2B for comparison to regulatory limits. The complete laboratory reports are also attached.

Total metals are summarized in Table 2A. Total constituent concentrations are difficult to interpret, and to our knowledge, no strict regulatory limits apply to those analyses. The table contains comparisons to the limits stated in the Distribution of Residual Solids (503 Exempt) Permit issued to Progress Energy Carolinas, Inc. by the State of North Carolina. Only the Arsenic concentration (83 mg/kg) slightly exceeded the permit concentration (75 mg/kg).

Tables 2B and 2C are summaries of concentrations of detected constituents from the SPLP and TCLP analyses, respectively (SPLP Sulfate, Nitrate, and Nitrite concentrations are summarized in Table 2). Those tables include comparisons to two lists of regulatory limits: the permit limits

and the NC 2L limits. The concentrations after extraction for both methods are well below the permit limits for all analyzed compounds.

Four metals (Arsenic, Barium, Chromium, and Selenium) exceeded the 2L limits for the SPLP procedure, and three metals (Arsenic, Barium, and Selenium) exceeded the 2L limits from the TCLP procedure. However, the 2L limits are meant to reflect groundwater or surface water concentrations (drinking water standards) and not necessarily concentrations of liquids within the engineered fill mass (essentially leachate concentrations). The 2L standards are referenced in those tables only to illustrate the low constituent concentrations resulting from the analytical methods.

Groundwater modeling is underway to estimate constituent concentrations in the nearest surface water stream to the Area 4 fill (Phases 1 and 1A). The modeling is being performed using the SPLP concentrations, since that procedure more closely simulates leachate generation in the proposed engineered fill (the TCLP procedure more closely resembles a municipal landfill environment). The modeling results will be presented separately upon completion.

The analytical results were below laboratory detection limits for all organic compounds analyzed (including pesticides, semi-volatiles, and volatiles), except methylene chloride. That compound is a very common laboratory contaminant, and we do not believe the concentration represents an actual specimen concentration.

Slope Stability: The physical test results were reviewed for general engineering behavioral characteristics. Slope stability analyses were performed on similar CCB engineered fills, using strength characteristics similar, or less favorable, than the results on this sample. Based on those tasks, we recommend maximum final slopes, within the CCB fill mass and including the cover layer(s) of 3H:1V or less. This slope is recommended to provide both static (long-term) and seismic stability of the engineered fill mass.

Published literature indicates textured flexible membranes can develop friction resistance along the surface mimicking the internal shear strength of the soil. As such, we recommend textured liners for the sloping portions (greater than 10 percent) of the liners and covers. If desired, smooth liners could be considered for the flat and gently sloping portions of the fill system.

Similarly, we recommend that a needle-punched geosynthetic clay liner (GCL) be used to provide adequate shear strength along sloping portions of the fill base.

Detailed slope stability analyses can be performed for specific slopes and liner components, if desired, for the Area 4 fill, once the site design is completed.

Compaction Specifications - Performance Specifications: Performance specifications are the preferred method for assuring construction quality for engineered fills and liner systems.

The physical test results indicate strength, hydraulic conductivity, and compressibility characteristics of the CCB's are similar to fills made up of naturally occurring soils in the project area. As such, CCB's and cover compaction specifications equivalent to customary requirements will result in a fill embankment satisfactory for most engineered applications, including

pavement support, slope stability and maintenance, and light to moderately loaded structures as may be proposed for use by the airport facility.

For Area 4, the following table presents our recommendations for compacting and testing the CCB fill and earthen components of the engineered fill system.

CCB/Soil Compaction and Testing Recommendations

Specification or QA/QC Activity	Test Method	Recommended Frequency
CCB Engineered Fill:		
Minimum Compaction Specification	ASTM D 698	95 Percent Standard Proctor Maximum Dry Density
Moisture Range at Compaction	ASTM D 2216 ASTM D 4959	-3 to +3 % Optimum Moisture Content
Field Density Test and Moisture Frequency	ASTM D 2937 ASTM D 1556 ASTM D 2922	1 test per 1,000 cubic yards of CCB placed (4 min. per visit)
Compaction (Proctor) Test Frequency	ASTM D 698	1 test per 10,000 cubic yards of CCB's (or observed change in properties)
Earth Components of Liner Systems:		
Minimum Compaction Specification	ASTM D 698	95 Percent Standard Proctor Maximum Dry Density
Moisture Range at Compaction	ASTM D 2216 ASTM D 4959	0 to +3 % Optimum Moisture Content
Field Density Test and Moisture Frequency	ASTM D 2937 ASTM D 1556 ASTM D 2922	5 tests per acre per foot thickness, or fraction thereof (4 min. per visit)
Compaction (Proctor) Test Frequency	ASTM D 698	1 test per 5,000 cubic yards of soils (or observed change in properties)
Grain Size Atterberg Limits	ASTM D 422 ASTM D 4318	1 test per 5,000 cubic yards
Hydraulic Conductivity Sampled from Completed Liner	ASTM D 698	1 test per acre per foot

The test results and general experience indicate that CCB properties are not especially sensitive to compaction moisture content; therefore, moisture contents occasionally varying outside of the recommended limits would be acceptable as long as the recommended minimum compaction requirement is achieved.

We understand the most likely future use of a portion of the engineered fill will be an aircraft taxiway or runway (a heavy-duty pavement application). Earthen pavement subgrades achieve most favorable elastic deflection and pavement subgrade (CBR) properties when compacted at or slightly dry of their optimum moisture contents. Also, final pavement design and construction

requirements might exceed the general engineered fill recommendations herein. If final pavement subgrade soils are to be placed as part of this fill project, the final one to two feet of the soil cover should be compacted to the specifications for that application.

In lieu of specific specifications or guidelines, we recommend that the final pavement subgrade soils be compacted to at least 100 percent of the material's Standard Proctor Maximum Dry Density, with compaction moisture contents between optimum and 3 percent dry of optimum. It should be noted that cover layers serving as hydraulic barriers achieve most favorable seepage properties if compacted slightly wet of optimum, so a zoned final grading plan might be advisable (one zone for cover purposes and one zone for final pavement support). More specific recommendations could be provided upon completion of a draft grading plan.

Recommendations concerning other components of the engineered fill system will be provided in a CQA document under separate cover. Those components include flexible membrane (HDPE) liners and covers, geosynthetic clay liners (GCL's), and drainage layers.

Closing: GeoTrack is pleased to be of service to you on this project. Please call if you have any questions concerning this letter or if we may provide additional assistance.

Respectfully submitted,
GeoTrack Technologies, Inc.



David D. Wilson, P.E.
Senior Engineer
NC Registration No. 17088

Attachments

Cc Mr. Norman Divers

**TABLE 1 – 6.3 PHYSICAL/ENGINEERING CHARACTERISTICS
ASHEVILLE AIRPORT AREA 4
GEOTRACK PROJECT NO. 10-2626-N**

Physical/Engineering Characteristic	Test Method	Test Result/ Applicable Parameters	Remarks
6.3.1 Grain Size Distribution	ASTM 422	17 Percent Sand 78 Percent Silt 6 Percent Clay <i>Grain Size Distribution Attached</i>	Sieve and Hydrometer
6.3.2 Specific Gravity	ASTM 854	Specific Gravity: $G_s = 2.21$	Moisture Content at Time of Sampling
6.3.3 Water Content	ASTM D 2216	Field Moisture Content: $w = 28.5\%$	Standard Proctor Compaction Test on combined fly ash and bottom ash sample
6.3.4 Compaction	ASTM D 698	Maximum Dry Density: $\gamma_{d\max} = 70.7$ pcf Optimum Moisture Cont.: $w_{op} = 31.1\%$ <i>Moisture Density Relationship Attached</i>	
6.3.5 Strength:			
6.3.5.1 Shear Strength	ASTM 4767	Total Cohesion: $C = 0.90$ ksf Total Angle of Int. Friction: $= 13^\circ$ Eff. Cohesion: $C' = 0$ Eff. Angle of Int. Friction: $\phi' = 34^\circ$ <i>Triaxial Shear Test Report Attached</i>	Consolidated Undrained Triaxial Shear Test with Pore Pressure Measurements Note 3
6.3.5.2 Compressive Strength	ASTM 2850	Total Cohesion: $C = 0.60$ ksf Total Angle of Int. Friction: $\phi = 19.5^\circ$ <i>Triaxial Shear Test Report Attached</i>	Unconsolidated Undrained Triaxial Shear Test. Unconfined Compressive Strength not Meaningful for Ash Samples Note 3
6.3.6 Hydraulic Conductivity	ASTM D 5084	Hyd. Conductivity: $k = 1.6 \times 10^{-4}$ cm/sec	Note 3
6.3.7 Compressibility	ASTM D 2435	<i>Consolidation Test Report Attached</i>	Note 3

- Notes:
1. Sample collected April 12, 2010
 2. The section numbers refer to the applicable section of ASTM E 2277, as referenced in the Compliance Spread Sheet
 3. Tests performed on specimens remolded in the laboratory to approximately 95 percent of the Standard Proctor Maximum Dry Density at approximately the Optimum Moisture Content.

Attachment 5

HELP Model and Supporting Information for Alternate Final Cover

This page intentionally left blank.

JAN/JUL	charah FEB/AUG	col on final MAR/SEP	cover top APR/OCT	deck-rev7 MAY/NOV	JUN/DEC
39.60	41.60	49.30	59.50	67.20	73.90
77.70	77.00	71.00	59.70	50.00	42.00

NOTE: SOLAR RADIATION DATA WAS SYNTHETICALLY GENERATED USING
 COEFFICIENTS FOR RALEIGH NORTH CAROLINA
 AND STATION LATITUDE = 35.87 DEGREES

LAYER DATA 1

 VALID FOR 100 YEARS

NOTE: INITIAL MOISTURE CONTENT OF THE LAYERS AND SNOW WATER WERE
 COMPUTED AS NEARLY STEADY-STATE VALUES BY THE PROGRAM.

LAYER 1

TYPE 1 - VERTICAL PERCOLATION LAYER

MATERIAL TEXTURE NUMBER 9

THICKNESS = 6.00 INCHES
 POROSITY = 0.5010 VOL/VOL
 FIELD CAPACITY = 0.2840 VOL/VOL
 WILTING POINT = 0.1350 VOL/VOL
 INITIAL SOIL WATER CONTENT = 0.2864 VOL/VOL
 EFFECTIVE SAT. HYD. CONDUCT. = 0.1900E-03 CM/SEC
 NOTE: SATURATED HYDRAULIC CONDUCTIVITY IS MULTIPLIED BY 5.00
 FOR ROOT CHANNELS IN TOP HALF OF EVAPORATIVE ZONE.

LAYER 2

TYPE 1 - VERTICAL PERCOLATION LAYER

MATERIAL TEXTURE NUMBER 0

THICKNESS = 66.00 INCHES
 POROSITY = 0.4710 VOL/VOL
 FIELD CAPACITY = 0.3420 VOL/VOL
 WILTING POINT = 0.2100 VOL/VOL
 INITIAL SOIL WATER CONTENT = 0.3962 VOL/VOL
 EFFECTIVE SAT. HYD. CONDUCT. = 0.4000E-04 CM/SEC

LAYER 3

TYPE 2 - LATERAL DRAINAGE LAYER

MATERIAL TEXTURE NUMBER 0

THICKNESS = 0.21 INCHES
 POROSITY = 0.8500 VOL/VOL

charah colon final cover top deck-rev7

FIELD CAPACITY	=	0.0100	VOL/VOL
WILTING POINT	=	0.0050	VOL/VOL
INITIAL SOIL WATER CONTENT	=	0.2366	VOL/VOL
EFFECTIVE SAT. HYD. CONDUCT.	=	4.760	CM/SEC
SLOPE	=	2.00	PERCENT
DRAINAGE LENGTH	=	500.0	FEET

LAYER 4

TYPE 4 - FLEXIBLE MEMBRANE LINER

MATERIAL TEXTURE NUMBER 36

THICKNESS	=	0.04	INCHES
EFFECTIVE SAT. HYD. CONDUCT.	=	0.4000E-12	CM/SEC
FML PINHOLE DENSITY	=	1.00	HOLES/ACRE
FML INSTALLATION DEFECTS	=	1.00	HOLES/ACRE
FML PLACEMENT QUALITY	=	3	- GOOD

LAYER 5

TYPE 1 - VERTICAL PERCOLATION LAYER

MATERIAL TEXTURE NUMBER 0

THICKNESS	=	720.00	INCHES
POROSITY	=	0.5410	VOL/VOL
FIELD CAPACITY	=	0.1870	VOL/VOL
WILTING POINT	=	0.0470	VOL/VOL
INITIAL SOIL WATER CONTENT	=	0.1870	VOL/VOL
EFFECTIVE SAT. HYD. CONDUCT.	=	0.1600E-03	CM/SEC

LAYER 6

TYPE 2 - LATERAL DRAINAGE LAYER

MATERIAL TEXTURE NUMBER 0

THICKNESS	=	0.26	INCHES
POROSITY	=	0.8500	VOL/VOL
FIELD CAPACITY	=	0.0100	VOL/VOL
WILTING POINT	=	0.0050	VOL/VOL
INITIAL SOIL WATER CONTENT	=	0.0100	VOL/VOL
EFFECTIVE SAT. HYD. CONDUCT.	=	9.700	CM/SEC
SLOPE	=	2.00	PERCENT
DRAINAGE LENGTH	=	950.0	FEET

LAYER 7

TYPE 4 - FLEXIBLE MEMBRANE LINER

MATERIAL TEXTURE NUMBER 35

THICKNESS	=	0.06	INCHES
EFFECTIVE SAT. HYD. CONDUCT.	=	0.2000E-12	CM/SEC
FML PINHOLE DENSITY	=	1.00	HOLES/ACRE
FML INSTALLATION DEFECTS	=	1.00	HOLES/ACRE
FML PLACEMENT QUALITY	=	3	- GOOD

LAYER 8

TYPE 1 - VERTICAL PERCOLATION LAYER

MATERIAL TEXTURE NUMBER 17

THICKNESS	=	0.25	INCHES
POROSITY	=	0.7500	VOL/VOL
FIELD CAPACITY	=	0.7470	VOL/VOL
WILTING POINT	=	0.4000	VOL/VOL
INITIAL SOIL WATER CONTENT	=	0.7470	VOL/VOL
EFFECTIVE SAT. HYD. CONDUCT.	=	0.3000E-08	CM/SEC

LAYER 9

TYPE 3 - BARRIER SOIL LINER

MATERIAL TEXTURE NUMBER 16

THICKNESS	=	18.00	INCHES
POROSITY	=	0.4270	VOL/VOL
FIELD CAPACITY	=	0.4180	VOL/VOL
WILTING POINT	=	0.3670	VOL/VOL
INITIAL SOIL WATER CONTENT	=	0.4270	VOL/VOL
EFFECTIVE SAT. HYD. CONDUCT.	=	0.1000E-06	CM/SEC

GENERAL DESIGN AND EVAPORATIVE ZONE DATA 1

VALID FOR 100 YEARS

NOTE: SCS RUNOFF CURVE NUMBER WAS USER-SPECIFIED.

SCS RUNOFF CURVE NUMBER	=	89.00	
FRACTION OF AREA ALLOWING RUNOFF	=	100.0	PERCENT
AREA PROJECTED ON HORIZONTAL PLANE	=	1.000	ACRES
EVAPORATIVE ZONE DEPTH	=	18.0	INCHES
INITIAL WATER IN EVAPORATIVE ZONE	=	6.047	INCHES
UPPER LIMIT OF EVAPORATIVE STORAGE	=	8.658	INCHES
FIELD CAPACITY OF EVAPORATIVE ZONE	=	5.808	INCHES
LOWER LIMIT OF EVAPORATIVE STORAGE	=	3.330	INCHES
SOIL EVAPORATION ZONE DEPTH	=	18.000	INCHES
INITIAL SNOW WATER	=	0.000	INCHES
INITIAL INTERCEPTION WATER	=	0.000	INCHES
INITIAL WATER IN LAYER MATERIALS	=	170.434	INCHES
TOTAL INITIAL WATER	=	170.434	INCHES
TOTAL SUBSURFACE INFLOW	=	0.00	INCHES/YEAR

EVAPOTRANSPIRATION DATA 1

VALID FOR 100 YEARS

charah colon final cover top deck-rev7

NOTE: EVAPOTRANSPIRATION DATA WAS OBTAINED FROM
RALEIGH NORTH CAROLINA

STATION LATITUDE = 35.87 DEGREES
 MAXIMUM LEAF AREA INDEX = 4.50
 START OF GROWING SEASON (JULIAN DATE) = 86
 END OF GROWING SEASON (JULIAN DATE) = 310
 EVAPORATIVE ZONE DEPTH = 18.0 INCHES
 AVERAGE ANNUAL WIND SPEED = 7.70 MPH
 AVERAGE 1ST QUARTER RELATIVE HUMIDITY = 66.0 %
 AVERAGE 2ND QUARTER RELATIVE HUMIDITY = 70.0 %
 AVERAGE 3RD QUARTER RELATIVE HUMIDITY = 78.0 %
 AVERAGE 4TH QUARTER RELATIVE HUMIDITY = 72.0 %

FINAL WATER STORAGE AT END OF YEAR 100

LAYER	(INCHES)	(VOL/VOL)
1	1.6981	0.2830
2	25.2440	0.3825
3	0.0505	0.2404
4	0.0000	0.0000
5	134.6400	0.1870
6	0.0026	0.0101
7	0.0000	0.0000
8	0.1867	0.7470
9	7.6860	0.4270
TOTAL WATER IN LAYERS	169.508	
SNOW WATER	0.000	
INTERCEPTION WATER	0.000	
TOTAL FINAL WATER	169.508	

PEAK DAILY VALUES FOR YEARS 1 THROUGH 100

	charah col on fi nal cover top deck-rev7 (INCHES)	(CU. FT.)
PRECI PI TATI ON	5.22	18948.600
RUNOFF	3.036	11019.6533
DRAINAGE COLLECTED FROM LAYER 3	0.23231	843.27509
PERCOLATI ON/LEAKAGE THROUGH LAYER 4	0.003584	13.00886
AVERAGE HEAD ON TOP OF LAYER 4	36.103	
MAXI MUM HEAD ON TOP OF LAYER 4	45.513	
LOCATI ON OF MAXI MUM HEAD I N LAYER 3 (DI STANCE FROM DRAIN)	192.0 FEET	
DRAINAGE COLLECTED FROM LAYER 6	0.00450	16.34715
PERCOLATI ON/LEAKAGE THROUGH LAYER 7	0.000000	0.00003
AVERAGE HEAD ON TOP OF LAYER 7	0.004	
MAXI MUM HEAD ON TOP OF LAYER 7	0.040	
LOCATI ON OF MAXI MUM HEAD I N LAYER 6 (DI STANCE FROM DRAIN)	0.0 FEET	
PERCOLATI ON/LEAKAGE THROUGH LAYER 9	0.000000	0.00003
AVERAGE HEAD ON TOP OF LAYER 9	0.000	
SNOW WATER	3.56	12918.0498
MAXI MUM VEG. SOI L WATER (VOL/VOL)		0.4229
MI NI MUM VEG. SOI L WATER (VOL/VOL)		0.1850

*** Maxi mum heads are computed using McEnroe's equati ons. ***

Reference: Maxi mum Saturated Depth over Landfi ll Li ner
by Bruce M. McEnroe, Uni versi ty of Kansas
ASCE Journal of Envi ronmental Engi neering
Vol. 119, No. 2, March 1993, pp. 262-270.

AVERAGE MONTHLY VALUES IN INCHES FOR YEARS 1 THROUGH 100

	JAN/JUL	FEB/AUG	MAR/SEP	APR/OCT	MAY/NOV	JUN/DEC
PRECI PI TATI ON						
TOTALS	3.66 4.28	3.21 4.91	3.90 3.41	3.07 2.84	3.53 2.99	3.90 2.98

	charah	col on	fi nal	cover	top	deck-rev7	
STD. DEVI ATI ONS	1. 92	1. 63	1. 42	1. 34	1. 84	2. 01	
	1. 90	2. 75	2. 13	1. 73	1. 84	1. 56	
RUNOFF							

TOTALS	0. 404	0. 309	0. 281	0. 126	0. 222	0. 257	
	0. 301	0. 592	0. 389	0. 271	0. 312	0. 267	
STD. DEVI ATI ONS	0. 494	0. 441	0. 290	0. 173	0. 366	0. 359	
	0. 405	0. 773	0. 535	0. 375	0. 408	0. 325	
POTENTI AL EVAPOTRANSPI RATI ON							

TOTALS	1. 867	2. 198	3. 605	4. 849	6. 329	7. 019	
	6. 807	6. 063	4. 589	3. 407	2. 162	1. 609	
STD. DEVI ATI ONS	0. 176	0. 222	0. 268	0. 325	0. 284	0. 302	
	0. 314	0. 271	0. 277	0. 205	0. 168	0. 131	
ACTUAL EVAPOTRANSPI RATI ON							

TOTALS	1. 126	1. 432	2. 315	3. 407	4. 019	3. 563	
	3. 856	3. 727	2. 573	1. 138	0. 890	0. 842	
STD. DEVI ATI ONS	0. 223	0. 258	0. 346	0. 593	1. 288	1. 442	
	1. 389	1. 305	1. 047	0. 316	0. 222	0. 212	
LATERAL DRAINAGE COLLECTED FROM LAYER 3							

TOTALS	1. 7591	1. 8285	1. 6542	1. 2669	0. 8305	0. 4630	
	0. 1506	0. 0958	0. 1801	0. 2473	0. 4566	1. 1402	
STD. DEVI ATI ONS	1. 0680	1. 1811	0. 9776	0. 7343	0. 3596	0. 2408	
	0. 2059	0. 2376	0. 5424	0. 4872	0. 6767	1. 1167	
PERCOLATI ON/LEAKAGE THROUGH LAYER 4							

TOTALS	0. 0013	0. 0027	0. 0008	0. 0005	0. 0003	0. 0002	
	0. 0001	0. 0000	0. 0003	0. 0001	0. 0002	0. 0008	
STD. DEVI ATI ONS	0. 0023	0. 0078	0. 0011	0. 0005	0. 0001	0. 0001	
	0. 0001	0. 0001	0. 0021	0. 0002	0. 0004	0. 0018	
LATERAL DRAINAGE COLLECTED FROM LAYER 6							

TOTALS	0. 0011	0. 0025	0. 0012	0. 0005	0. 0003	0. 0002	
	0. 0001	0. 0000	0. 0003	0. 0001	0. 0002	0. 0008	
STD. DEVI ATI ONS	0. 0019	0. 0062	0. 0038	0. 0006	0. 0001	0. 0001	
	0. 0001	0. 0001	0. 0021	0. 0002	0. 0004	0. 0018	
PERCOLATI ON/LEAKAGE THROUGH LAYER 7							

TOTALS	0. 0000	0. 0000	0. 0000	0. 0000	0. 0000	0. 0000	
	0. 0000	0. 0000	0. 0000	0. 0000	0. 0000	0. 0000	
STD. DEVI ATI ONS	0. 0000	0. 0000	0. 0000	0. 0000	0. 0000	0. 0000	
	0. 0000	0. 0000	0. 0000	0. 0000	0. 0000	0. 0000	
PERCOLATI ON/LEAKAGE THROUGH LAYER 9							

TOTALS	0. 0000	0. 0000	0. 0000	0. 0000	0. 0000	0. 0000	
	0. 0000	0. 0000	0. 0000	0. 0000	0. 0000	0. 0000	

charah col on final cover top deck-rev7

STD. DEVIATIONS	0.0000	0.0000	0.0000	0.0000	0.0000	0.0000
	0.0000	0.0000	0.0000	0.0000	0.0000	0.0000

 AVERAGES OF MONTHLY AVERAGED DAILY HEADS (INCHES)

DAI LY AVERAGE HEAD ON TOP OF LAYER 4

AVERAGES	0.2629	0.7898	0.1304	0.0592	0.0248	0.0143
	0.0045	0.0029	0.0695	0.0097	0.0257	0.1590
STD. DEVIATIONS	0.6663	2.6631	0.2749	0.1407	0.0108	0.0074
	0.0062	0.0071	0.6525	0.0347	0.0846	0.5056

DAI LY AVERAGE HEAD ON TOP OF LAYER 7

AVERAGES	0.0000	0.0001	0.0000	0.0000	0.0000	0.0000
	0.0000	0.0000	0.0000	0.0000	0.0000	0.0000
STD. DEVIATIONS	0.0001	0.0002	0.0001	0.0000	0.0000	0.0000
	0.0000	0.0000	0.0001	0.0000	0.0000	0.0001

DAI LY AVERAGE HEAD ON TOP OF LAYER 9

AVERAGES	0.0000	0.0000	0.0000	0.0000	0.0000	0.0000
	0.0000	0.0000	0.0000	0.0000	0.0000	0.0000
STD. DEVIATIONS	0.0000	0.0000	0.0000	0.0000	0.0000	0.0000
	0.0000	0.0000	0.0000	0.0000	0.0000	0.0000

AVERAGE ANNUAL TOTALS & (STD. DEVIATIONS) FOR YEARS 1 THROUGH 100

	INCHES		CU. FEET	PERCENT
	-----	-----	-----	-----
PRECIPI TATI ON	42.69	(6.985)	154963.6	100.00
RUNOFF	3.730	(1.7277)	13541.61	8.739
POTENTI AL EVAPOTRANSPI RATI ON	50.506	(0.9138)	183335.89	
ACTUAL EVAPOTRANSPI RATI ON	28.888	(3.1727)	104864.87	67.671
LATERAL DRAI NAGE COLLECTED FROM LAYER 3	10.07277	(3.63240)	36564.148	23.59531
PERCOLATI ON/LEAKAGE THROUGH LAYER 4	0.00733	(0.01028)	26.610	0.01717
AVERAGE HEAD ON TOP OF LAYER 4	0.129	(0.277)		
LATERAL DRAI NAGE COLLECTED	0.00733	(0.01028)	26.603	0.01717

charah col on fi nal cover top deck-rev7

FROM LAYER 6

PERCOLATI ON/LEAKAGE THROUGH LAYER 7	0.00000 (0.00000)	0.007	0.00000
AVERAGE HEAD ON TOP OF LAYER 7	0.000 (0.000)		
PERCOLATI ON/LEAKAGE THROUGH LAYER 9	0.00000 (0.00000)	0.007	0.00000
AVERAGE HEAD ON TOP OF LAYER 9	0.000 (0.000)		
CHANGE IN WATER STORAGE	-0.009 (1.6409)	-33.62	-0.022

JAN/JUL	charah col on final FEB/AUG	cover-side slope rev7 MAR/SEP	APR/OCT	MAY/NOV	JUN/DEC
39.60	41.60	49.30	59.50	67.20	73.90
77.70	77.00	71.00	59.70	50.00	42.00

NOTE: SOLAR RADIATION DATA WAS SYNTHETICALLY GENERATED USING
 COEFFICIENTS FOR RALEIGH NORTH CAROLINA
 AND STATION LATITUDE = 35.87 DEGREES

LAYER DATA 1

 VALID FOR 100 YEARS

NOTE: INITIAL MOISTURE CONTENT OF THE LAYERS AND SNOW WATER WERE
 COMPUTED AS NEARLY STEADY-STATE VALUES BY THE PROGRAM.

LAYER 1

TYPE 1 - VERTICAL PERCOLATION LAYER

MATERIAL TEXTURE NUMBER 9

THICKNESS = 6.00 INCHES
 POROSITY = 0.5010 VOL/VOL
 FIELD CAPACITY = 0.2840 VOL/VOL
 WILTING POINT = 0.1350 VOL/VOL
 INITIAL SOIL WATER CONTENT = 0.2868 VOL/VOL
 EFFECTIVE SAT. HYD. CONDUCT. = 0.1900E-03 CM/SEC
 NOTE: SATURATED HYDRAULIC CONDUCTIVITY IS MULTIPLIED BY 5.00
 FOR ROOT CHANNELS IN TOP HALF OF EVAPORATIVE ZONE.

LAYER 2

TYPE 1 - VERTICAL PERCOLATION LAYER

MATERIAL TEXTURE NUMBER 0

THICKNESS = 42.00 INCHES
 POROSITY = 0.4710 VOL/VOL
 FIELD CAPACITY = 0.3420 VOL/VOL
 WILTING POINT = 0.2100 VOL/VOL
 INITIAL SOIL WATER CONTENT = 0.3923 VOL/VOL
 EFFECTIVE SAT. HYD. CONDUCT. = 0.4000E-04 CM/SEC

LAYER 3

TYPE 2 - LATERAL DRAINAGE LAYER

MATERIAL TEXTURE NUMBER 0

THICKNESS = 0.21 INCHES
 POROSITY = 0.8500 VOL/VOL

charah col on final cover-side slope rev7

FIELD CAPACITY	=	0.0100	VOL/VOL
WILTING POINT	=	0.0050	VOL/VOL
INITIAL SOIL WATER CONTENT	=	0.0345	VOL/VOL
EFFECTIVE SAT. HYD. CONDUCT.	=	2.760	CM/SEC
SLOPE	=	25.00	PERCENT
DRAINAGE LENGTH	=	140.0	FEET

LAYER 4

TYPE 4 - FLEXIBLE MEMBRANE LINER

MATERIAL TEXTURE NUMBER 36

THICKNESS	=	0.04	INCHES
EFFECTIVE SAT. HYD. CONDUCT.	=	0.4000E-12	CM/SEC
FML PINHOLE DENSITY	=	1.00	HOLES/ACRE
FML INSTALLATION DEFECTS	=	1.00	HOLES/ACRE
FML PLACEMENT QUALITY	=	3	- GOOD

LAYER 5

TYPE 1 - VERTICAL PERCOLATION LAYER

MATERIAL TEXTURE NUMBER 0

THICKNESS	=	360.00	INCHES
POROSITY	=	0.5410	VOL/VOL
FIELD CAPACITY	=	0.1870	VOL/VOL
WILTING POINT	=	0.0470	VOL/VOL
INITIAL SOIL WATER CONTENT	=	0.1870	VOL/VOL
EFFECTIVE SAT. HYD. CONDUCT.	=	0.1600E-03	CM/SEC

LAYER 6

TYPE 2 - LATERAL DRAINAGE LAYER

MATERIAL TEXTURE NUMBER 0

THICKNESS	=	0.26	INCHES
POROSITY	=	0.8500	VOL/VOL
FIELD CAPACITY	=	0.0100	VOL/VOL
WILTING POINT	=	0.0050	VOL/VOL
INITIAL SOIL WATER CONTENT	=	0.0100	VOL/VOL
EFFECTIVE SAT. HYD. CONDUCT.	=	9.700	CM/SEC
SLOPE	=	2.00	PERCENT
DRAINAGE LENGTH	=	950.0	FEET

LAYER 7

TYPE 4 - FLEXIBLE MEMBRANE LINER

MATERIAL TEXTURE NUMBER 35

THICKNESS	=	0.06	INCHES
EFFECTIVE SAT. HYD. CONDUCT.	=	0.2000E-12	CM/SEC
FML PINHOLE DENSITY	=	1.00	HOLES/ACRE
FML INSTALLATION DEFECTS	=	1.00	HOLES/ACRE
FML PLACEMENT QUALITY	=	3	- GOOD

LAYER 8

TYPE 1 - VERTICAL PERCOLATION LAYER

MATERIAL TEXTURE NUMBER 17

THICKNESS	=	0.25	INCHES
POROSITY	=	0.7500	VOL/VOL
FIELD CAPACITY	=	0.7470	VOL/VOL
WILTING POINT	=	0.4000	VOL/VOL
INITIAL SOIL WATER CONTENT	=	0.7470	VOL/VOL
EFFECTIVE SAT. HYD. CONDUCT.	=	0.3000E-08	CM/SEC

LAYER 9

TYPE 3 - BARRIER SOIL LINER

MATERIAL TEXTURE NUMBER 16

THICKNESS	=	18.00	INCHES
POROSITY	=	0.4270	VOL/VOL
FIELD CAPACITY	=	0.4180	VOL/VOL
WILTING POINT	=	0.3670	VOL/VOL
INITIAL SOIL WATER CONTENT	=	0.4270	VOL/VOL
EFFECTIVE SAT. HYD. CONDUCT.	=	0.1000E-06	CM/SEC

GENERAL DESIGN AND EVAPORATIVE ZONE DATA 1

VALID FOR 100 YEARS

NOTE: SCS RUNOFF CURVE NUMBER WAS USER-SPECIFIED.

SCS RUNOFF CURVE NUMBER	=	89.00	
FRACTION OF AREA ALLOWING RUNOFF	=	100.0	PERCENT
AREA PROJECTED ON HORIZONTAL PLANE	=	1.000	ACRES
EVAPORATIVE ZONE DEPTH	=	18.0	INCHES
INITIAL WATER IN EVAPORATIVE ZONE	=	6.074	INCHES
UPPER LIMIT OF EVAPORATIVE STORAGE	=	8.658	INCHES
FIELD CAPACITY OF EVAPORATIVE ZONE	=	5.808	INCHES
LOWER LIMIT OF EVAPORATIVE STORAGE	=	3.330	INCHES
SOIL EVAPORATION ZONE DEPTH	=	18.000	INCHES
INITIAL SNOW WATER	=	0.000	INCHES
INITIAL INTERCEPTION WATER	=	0.000	INCHES
INITIAL WATER IN LAYER MATERIALS	=	93.398	INCHES
TOTAL INITIAL WATER	=	93.398	INCHES
TOTAL SUBSURFACE INFLOW	=	0.00	INCHES/YEAR

EVAPOTRANSPIRATION DATA 1

VALID FOR 100 YEARS

NOTE: EVAPOTRANSPIRATION DATA WAS OBTAINED FROM
RALEIGH NORTH CAROLINA

STATION LATITUDE = 35.87 DEGREES
 MAXIMUM LEAF AREA INDEX = 4.50
 START OF GROWING SEASON (JULIAN DATE) = 86
 END OF GROWING SEASON (JULIAN DATE) = 310
 EVAPORATIVE ZONE DEPTH = 18.0 INCHES
 AVERAGE ANNUAL WIND SPEED = 7.70 MPH
 AVERAGE 1ST QUARTER RELATIVE HUMIDITY = 66.0 %
 AVERAGE 2ND QUARTER RELATIVE HUMIDITY = 70.0 %
 AVERAGE 3RD QUARTER RELATIVE HUMIDITY = 78.0 %
 AVERAGE 4TH QUARTER RELATIVE HUMIDITY = 72.0 %

FINAL WATER STORAGE AT END OF YEAR 100

LAYER	(INCHES)	(VOL/VOL)
1	1.6985	0.2831
2	15.8912	0.3784
3	0.0045	0.0215
4	0.0000	0.0000
5	67.3200	0.1870
6	0.0026	0.0100
7	0.0000	0.0000
8	0.1867	0.7470
9	7.6860	0.4270
TOTAL WATER IN LAYERS	92.790	
SNOW WATER	0.000	
INTERCEPTION WATER	0.000	
TOTAL FINAL WATER	92.790	

PEAK DAILY VALUES FOR YEARS 1 THROUGH 100

	charah col on final cover-side slope rev7 (INCHES)	(CU. FT.)
PRECIPITATION	5.22	18948.600
RUNOFF	3.211	11655.5000
DRAINAGE COLLECTED FROM LAYER 3	0.74226	2694.39526
PERCOLATION/LEAKAGE THROUGH LAYER 4	0.000012	0.04331
AVERAGE HEAD ON TOP OF LAYER 4	0.028	
MAXIMUM HEAD ON TOP OF LAYER 4	0.077	
LOCATION OF MAXIMUM HEAD IN LAYER 3 (DISTANCE FROM DRAIN)	0.0 FEET	
DRAINAGE COLLECTED FROM LAYER 6	0.00001	0.03708
PERCOLATION/LEAKAGE THROUGH LAYER 7	0.000000	0.00002
AVERAGE HEAD ON TOP OF LAYER 7	0.000	
MAXIMUM HEAD ON TOP OF LAYER 7	0.039	
LOCATION OF MAXIMUM HEAD IN LAYER 6 (DISTANCE FROM DRAIN)	0.0 FEET	
PERCOLATION/LEAKAGE THROUGH LAYER 9	0.000000	0.00002
AVERAGE HEAD ON TOP OF LAYER 9	0.000	
SNOW WATER	3.56	12918.0498
MAXIMUM VEG. SOIL WATER (VOL/VOL)		0.4338
MINIMUM VEG. SOIL WATER (VOL/VOL)		0.1850

*** Maximum heads are computed using McEnroe's equations. ***

Reference: Maximum Saturated Depth over Landfill Liner
by Bruce M. McEnroe, University of Kansas
ASCE Journal of Environmental Engineering
Vol. 119, No. 2, March 1993, pp. 262-270.

AVERAGE MONTHLY VALUES IN INCHES FOR YEARS 1 THROUGH 100

	JAN/JUL	FEB/AUG	MAR/SEP	APR/OCT	MAY/NOV	JUN/DEC
PRECIPITATION						
TOTALS	3.66 4.28	3.21 4.91	3.90 3.41	3.07 2.84	3.53 2.99	3.90 2.98

	charah	col on	fi nal	cover-side	slope	rev7	
STD. DEVIATI ONS	1. 92	1. 63	1. 42	1. 34	1. 84	2. 01	
	1. 90	2. 75	2. 13	1. 73	1. 84	1. 56	
RUNOFF							

TOTALS	0. 428	0. 332	0. 302	0. 135	0. 226	0. 261	
	0. 309	0. 606	0. 401	0. 283	0. 333	0. 281	
STD. DEVIATI ONS	0. 520	0. 474	0. 314	0. 189	0. 376	0. 367	
	0. 419	0. 806	0. 558	0. 395	0. 441	0. 341	
POTENTI AL EVAPOTRANSPI RATI ON							

TOTALS	1. 867	2. 198	3. 605	4. 849	6. 329	7. 019	
	6. 807	6. 063	4. 589	3. 407	2. 162	1. 609	
STD. DEVIATI ONS	0. 176	0. 222	0. 268	0. 325	0. 284	0. 302	
	0. 314	0. 271	0. 277	0. 205	0. 168	0. 131	
ACTUAL EVAPOTRANSPI RATI ON							

TOTALS	1. 126	1. 432	2. 314	3. 413	4. 090	3. 579	
	3. 866	3. 734	2. 580	1. 135	0. 887	0. 841	
STD. DEVIATI ONS	0. 223	0. 258	0. 348	0. 588	1. 287	1. 451	
	1. 395	1. 310	1. 047	0. 314	0. 221	0. 212	
LATERAL DRAINAGE COLLECTED FROM LAYER 3							

TOTALS	1. 9347	1. 7383	1. 6107	1. 0547	0. 5151	0. 1299	
	0. 0548	0. 0987	0. 1975	0. 2796	0. 7483	1. 4381	
STD. DEVIATI ONS	1. 0786	1. 2296	0. 9777	0. 6318	0. 3415	0. 2339	
	0. 1718	0. 3064	0. 5136	0. 5977	0. 9110	1. 1331	
PERCOLATI ON/LEAKAGE THROUGH LAYER 4							

TOTALS	0. 0001	0. 0000	0. 0000	0. 0000	0. 0000	0. 0000	
	0. 0000	0. 0000	0. 0000	0. 0000	0. 0000	0. 0000	
STD. DEVIATI ONS	0. 0000	0. 0000	0. 0000	0. 0000	0. 0000	0. 0000	
	0. 0000	0. 0000	0. 0000	0. 0000	0. 0000	0. 0000	
LATERAL DRAINAGE COLLECTED FROM LAYER 6							

TOTALS	0. 0001	0. 0000	0. 0000	0. 0000	0. 0000	0. 0000	
	0. 0000	0. 0000	0. 0000	0. 0000	0. 0000	0. 0000	
STD. DEVIATI ONS	0. 0000	0. 0000	0. 0000	0. 0000	0. 0000	0. 0000	
	0. 0000	0. 0000	0. 0000	0. 0000	0. 0000	0. 0000	
PERCOLATI ON/LEAKAGE THROUGH LAYER 7							

TOTALS	0. 0000	0. 0000	0. 0000	0. 0000	0. 0000	0. 0000	
	0. 0000	0. 0000	0. 0000	0. 0000	0. 0000	0. 0000	
STD. DEVIATI ONS	0. 0000	0. 0000	0. 0000	0. 0000	0. 0000	0. 0000	
	0. 0000	0. 0000	0. 0000	0. 0000	0. 0000	0. 0000	
PERCOLATI ON/LEAKAGE THROUGH LAYER 9							

TOTALS	0. 0000	0. 0000	0. 0000	0. 0000	0. 0000	0. 0000	
	0. 0000	0. 0000	0. 0000	0. 0000	0. 0000	0. 0000	

charah col on final cover-side slope rev7

STD. DEVIATIONS	0.0000	0.0000	0.0000	0.0000	0.0000	0.0000
	0.0000	0.0000	0.0000	0.0000	0.0000	0.0000

 AVERAGES OF MONTHLY AVERAGED DAILY HEADS (INCHES)

DAI LY AVERAGE HEAD ON TOP OF LAYER 4

AVERAGES	0.0024	0.0023	0.0020	0.0013	0.0006	0.0002
	0.0001	0.0001	0.0003	0.0003	0.0009	0.0018
STD. DEVIATIONS	0.0013	0.0016	0.0012	0.0008	0.0004	0.0003
	0.0002	0.0004	0.0007	0.0007	0.0012	0.0014

DAI LY AVERAGE HEAD ON TOP OF LAYER 7

AVERAGES	0.0000	0.0000	0.0000	0.0000	0.0000	0.0000
	0.0000	0.0000	0.0000	0.0000	0.0000	0.0000
STD. DEVIATIONS	0.0000	0.0000	0.0000	0.0000	0.0000	0.0000
	0.0000	0.0000	0.0000	0.0000	0.0000	0.0000

DAI LY AVERAGE HEAD ON TOP OF LAYER 9

AVERAGES	0.0000	0.0000	0.0000	0.0000	0.0000	0.0000
	0.0000	0.0000	0.0000	0.0000	0.0000	0.0000
STD. DEVIATIONS	0.0000	0.0000	0.0000	0.0000	0.0000	0.0000
	0.0000	0.0000	0.0000	0.0000	0.0000	0.0000

AVERAGE ANNUAL TOTALS & (STD. DEVIATIONS) FOR YEARS 1 THROUGH 100

	INCHES		CU. FEET	PERCENT
	-----	-----	-----	-----
PRECIPI TATI ON	42.69	(6.985)	154963.6	100.00
RUNOFF	3.899	(1.8278)	14152.28	9.133
POTENTI AL EVAPOTRANSPI RATI ON	50.506	(0.9138)	183335.89	
ACTUAL EVAPOTRANSPI RATI ON	28.996	(3.2020)	105256.68	67.923
LATERAL DRAI NAGE COLLECTED FROM LAYER 3	9.80048	(3.58097)	35575.734	22.95748
PERCOLATI ON/LEAKAGE THROUGH LAYER 4	0.00028	(0.00009)	1.019	0.00066
AVERAGE HEAD ON TOP OF LAYER 4	0.001	(0.000)		
LATERAL DRAI NAGE COLLECTED	0.00028	(0.00009)	1.014	0.00065

charah col on fi nal cover-side slope rev7

FROM LAYER 6

PERCOLATI ON/LEAKAGE THROUGH LAYER 7	0. 00000 (0. 00000)	0. 005	0. 00000
AVERAGE HEAD ON TOP OF LAYER 7	0. 000 (0. 000)		
PERCOLATI ON/LEAKAGE THROUGH LAYER 9	0. 00000 (0. 00000)	0. 005	0. 00000
AVERAGE HEAD ON TOP OF LAYER 9	0. 000 (0. 000)		
CHANGE IN WATER STORAGE	-0. 006 (1. 3059)	-22. 09	-0. 014

HDR Engineering, Inc.

Job No _____

No. _____



Project Sanford Mine Final Cover
 Task Hydraulic Conductivity and Drainage Layer Capacity

Computed K. Perera
 Checked Ty

Date 10/16/2014
 Date 11/6/14

Problem

Determine the hydraulic conductivity and drainage capacity of the geocomposite drainage layer in the final cover top deck.

Transmissivity Calculations

Final cover liner from bottom to top

40-mil LLPE - Double-sided Geocomposite - 5.5 Ft low permeability soil- 6-inch top soil

Determine 100-hour transmissivity (Θ_{100}).

Use GSE 250-mil GSE FabriNet HF or equivalent (see attached cut sheet with product specifications).

$$\Theta_{allow} = \frac{\Theta_{100}}{RF_{CR} * RF_{CC} * RF_{BC}}$$

$$\Theta_{allow} = \Theta_{req} \cdot FS_D$$

$$\Theta_{req} = k \cdot b$$

where,

- Θ_{allow} = minimum allowable transmissivity of geocomposite (cm²/s)
- Θ_{req} = required transmissivity for site (cm²/s)
- FS_D = overall factor of safety for drainage
- Θ_{100} = transmissivity after 100 hrs. under expected load (cm²/s)
- RF_{CR} = reduction factor for creep deformation
- RF_{CC} = reduction factor for chemical clogging
- RF_{BC} = reduction factor for biological clogging
- k = saturated hydraulic conductivity (cm/s)
- b = thickness of geonet (cm)

Information based on product data for GSE FabriNet HF 250mil. Site specific testing is recommended before selecting the material for installation to confirm minimum transmissivity.

Parameters	Geocomposite (250-mil) @ 1,000 psf ⁽¹⁾
Slope	0.25
$FS_D^{(2)}$	2.0
$RF_{CR}^{(2)}$	1.02
$RF_{CC}^{(2)}$	1.1
$RF_{BC}^{(2)}$	1.4
Θ_{100} (m ² /s)	0.00095
Θ_{allow} (cm ² /s)	6.05
Θ_{req} (cm ² /s)	3.02
Manufactured Thickness (mils)	250
Manufactured Thickness (cm)	0.64
Design Hydraulic Conductivity (cm/s)	4.76
Retained Final Thickness (mils)	213.8

Notes:

1. psf = pounds per square foot
2. Reduction factors based on HDR experience and information provided by GSE.

HDR Engineering, Inc.

Project Sanford Mine Final Cover
 Task Hydraulic Conductivity and Drainage Layer Capacity

Job No _____

No _____



Computed K. Perera

Date 10/16/2014

Checked TX

Date 11/6/14

Drainage Capacity Calculations:

Selected Geocomposite:

250-mil double-sided GSE FabriNet HF or Similar

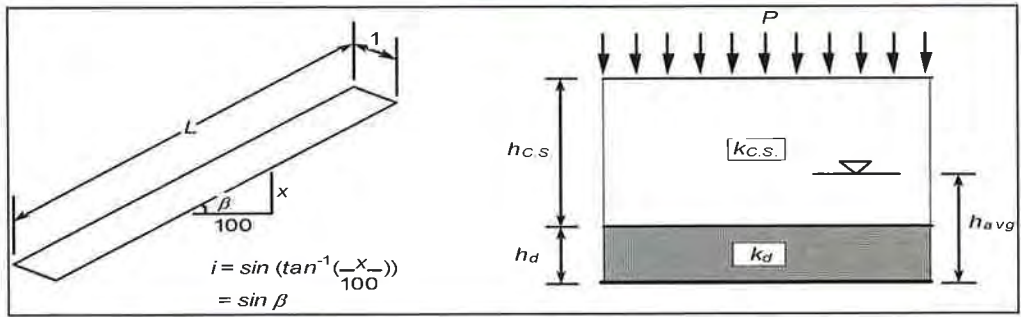

$L = 152.0$ m
 $\beta = 1.1$ °

$i = 0.0200$
 $L(\cos\beta) = 151.97$ m

Where:
 L = Max drainage length of slope measured along geomembrane (calculated from drawings)

$h_{c.s.}$ (Depth of Cover Soil) = 1829 mm
 h_d (Depth of Drainage Layer) = 5.4 mm
 $k_{c.s.}$ (Specification) = 4.0E-05 cm/s
 $k_d = 4.76E+00$ cm/s
 P , Rainfall Intensity = 208.03 mm/hr
 RC , Runoff Coefficient = 0.1

$h_{c.s.} = 1.8290$ m
 $h_d = 0.0054$ m
 $h_{c.s.} + h_d = 1.8344$ m
 $k_{c.s.} = 4.0E-07$ m/s
 $k_d = 4.8E-02$ m/s

β = Side Slope angle (maximum value)
 k = Hydraulic Conductivity
 P = Rainfall Intensity (From FDOT Drainage Manual)
 RC = Runoff Coefficient (conservative assumption)

q_i , Percolation through cover soil = 1.44 mm/hr
 ($q_i = k_{c.s.} \times 60 \text{ s/min} \times 60 \text{ min/hr} \times 10 \text{ mm/cm}$)

$$q_i = \begin{cases} k_{cover}, & \text{if } P(1-RC) \geq k_{cover} \\ P(1-RC), & \text{if } P(1-RC) < k_{cover} \end{cases}$$

Actual runoff = 206.59 mm/hr (Rainfall Intensity - Percolation through cover)
 $FLUX_{actual} = q_i \times L(\cos\beta) = 0.219$ m²/hr
 $FLUX_{allow} = k_d \times h_d \times \sin\beta = 0.019$ m²/hr

Drainage Layer Capacity ($FLUX_{allow} / FLUX_{actual}$) = **0.0850**

Conclusions:

- The saturated hydraulic conductivity of the geocomposite is calculated to be 4.76 cm/s.
- The drainage layer capacity is sufficient for the geocomposite in the final cover for 25-year storm event.

HDR Engineering, Inc.

Job No. _____

No. _____



Project Sanford Mine Final Cover
Task Hydraulic Conductivity and Drainage Layer Capacity

Computed K. Perera
Checked TX

Date 10/14/2014
Date 11/6/14

Problem

Determine the hydraulic conductivity and drainage capacity of the geocomposite drainage layer in the final cover side slope.

Transmissivity Calculations

Final cover liner from bottom to top

40-mil LLPE - Double-sided Geocomposite - 3.5-ft low permeability soil- 6-inch top soil

Determine 100-hour transmissivity (Θ_{100}).

Use GSE 250-mil GSE Fabrinet HF or equivalent (see attached cut sheet with product specifications).

$$\Theta_{allow} = \frac{\Theta_{100}}{RF_{CR} * RF_{CC} * RF_{BC}}$$

$$\Theta_{allow} = \Theta_{req} \cdot FS_D$$

$$\Theta_{req} = k \cdot b$$

where,

- Θ_{allow} = minimum allowable transmissivity of geocomposite (cm²/s)
- Θ_{req} = required transmissivity for site (cm²/s)
- FS_D = overall factor of safety for drainage
- Θ_{100} = transmissivity after 100 hrs. under expected load (cm²/s)
- RF_{CR} = reduction factor for creep deformation
- RF_{CC} = reduction factor for chemical clogging
- RF_{BC} = reduction factor for biological clogging
- k = saturated hydraulic conductivity (cm/s)
- b = thickness of geonet (cm)

Information based on product data for GSE FabriNet HF 250 mil. Site specific testing is recommended before selecting the material for installation to confirm minimum transmissivity.

Parameters	Geocomposite (250-mil) @ 1,000 psf ⁽¹⁾
Slope	0.25
$FS_D^{(2)}$	2.0
$RF_{CR}^{(2)}$	1.02
$RF_{CC}^{(2)}$	1.1
$RF_{BC}^{(2)}$	1.4
Θ_{100} (m ² /s)	0.00055
Θ_{allow} (cm ² /s)	3.50
Θ_{req} (cm ² /s)	1.75
Manufactured Thickness (mils)	250
Manufactured Thickness (cm)	0.64
Design Hydraulic Conductivity (cm/s)	2.76
Retained Final Thickness (mils)	213.8

Notes:

1. psf = pounds per square foot
2. Reduction factors based on HDR experience and information provided by GSE.

HDR Engineering, Inc.

Job No. _____

No. _____

HDR

Date: 10/14/2014

Date: 11/6/14

Project: Sanford Mine Final Cover

Computed: K. Perera

Task: Hydraulic Conductivity and Drainage Layer Capacity

Checked: Ty

Drainage Capacity Calculations:

Selected Geocomposite:

250-mil double-sided GSE FabriNet HF or Similar

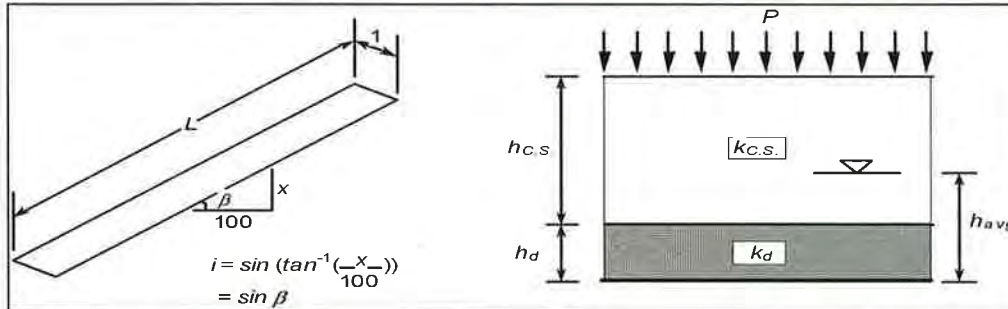

$$L = 42.6 \text{ m}$$

$$\beta = 14.0^\circ$$

$$i = 0.2425$$

$$L(\cos\beta) = 41.29 \text{ m}$$

Where:

L = Max drainage length of slope measured along geomembrane (calculated from drawings)

$h_{c,s}$ (Depth of Cover Soil)	1219	mm
h_d (Depth of Drainage Layer)	5.4	mm
$k_{c,s}$ (Specification)	4.0E-05	cm/s
k_d	2.76E+00	cm/s
P, Rainfall Intensity	208.03	mm/hr
RC, Runoff Coefficient	0.1	

$h_{c,s}$	1.2192	m
h_d	0.0054	m
$h_{c,s} + h_d$	1.2246	m
$k_{c,s}$	4.0E-07	m/s
k_d	2.8E-02	m/s

β = Side Slope angle (maximum value)

k = Hydraulic Conductivity

P = Rainfall Intensity (From FDOT Drainage Manual)

RC = Runoff Coefficient (conservative assumption)

$$q_i, \text{ Percolation through cover soil} = 1.44 \text{ mm/hr}$$

$$(q_i = k_{c,s} \times 60 \text{ s/min} \times 60 \text{ min/hr} \times 10 \text{ mm/cm})$$

$$q_i = \begin{cases} k_{cover}, & \text{if } P(1-RC) \geq k_{cover} \\ P(1-RC), & \text{if } P(1-RC) < k_{cover} \end{cases}$$

$$\text{Actual runoff} = 206.59 \text{ mm/hr (Rainfall Intensity - Percolation through cover)}$$

$$FLUX_{actual} = q_i \times L(\cos\beta) = 0.059 \text{ m}^2/\text{hr}$$

$$FLUX_{allow} = k_d \times h_d \times \sin\beta = 0.130 \text{ m}^2/\text{hr}$$

$$\text{Drainage Layer Capacity } (FLUX_{allow} / FLUX_{actual}) = 2.1857$$

Conclusions:

- The saturated hydraulic conductivity of the geocomposite is calculated to be 2.76 cm/s.
- The drainage layer capacity is sufficient for the geocomposite in the final cover for 25-year storm event.

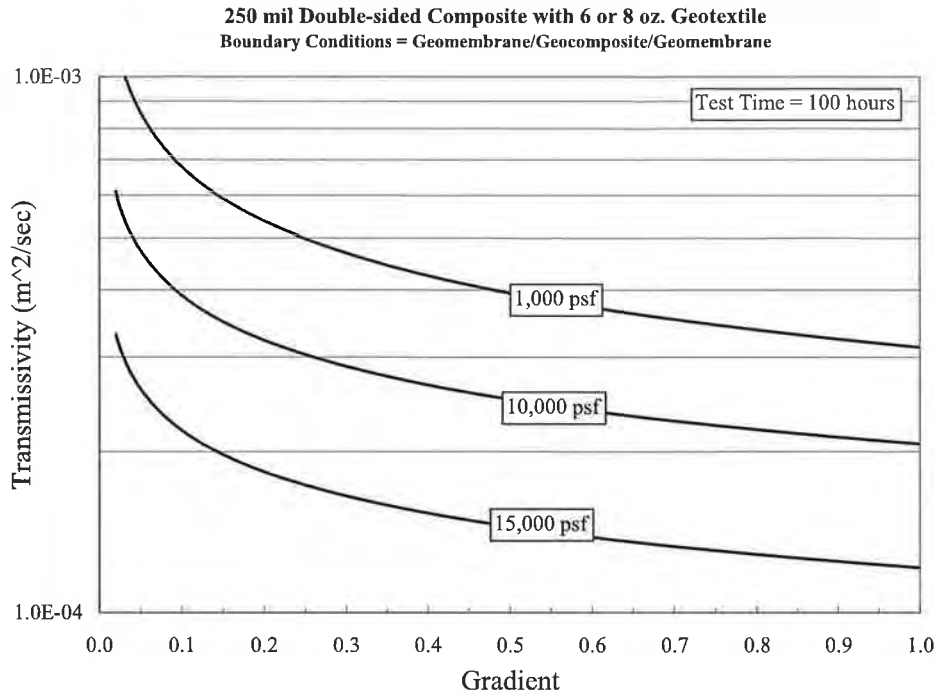

Figure A-5. Performance Transmissivity of a 250 mil GSE HyperNet HF geonet between Plates.

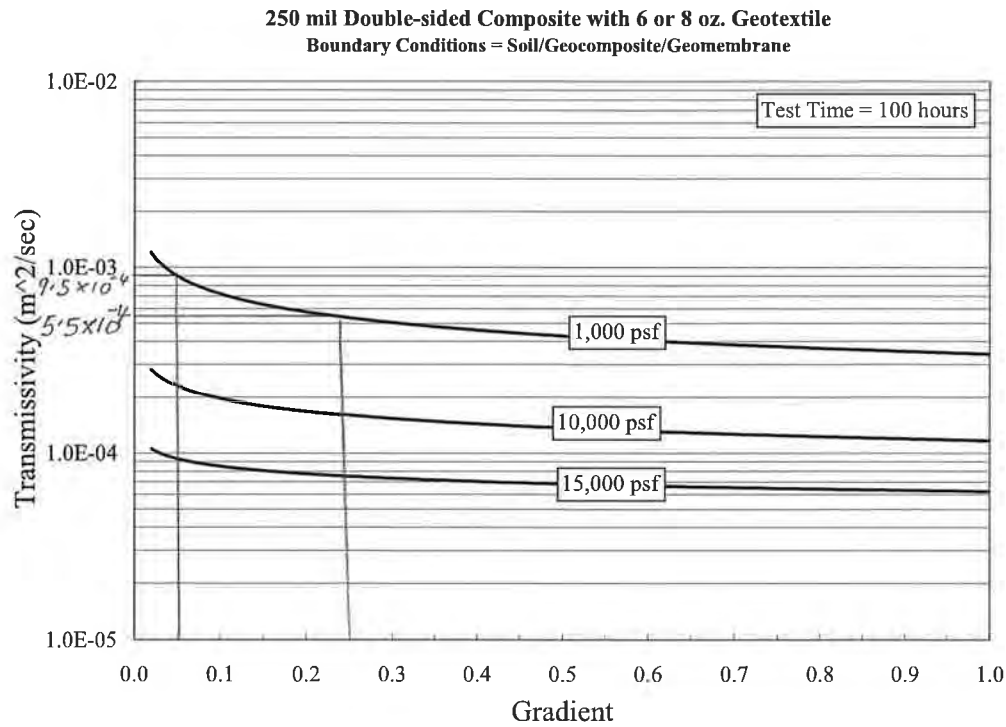

Figure A-6. Performance Transmissivity of a 250 mil GSE FabriNet HF geocomposite under Sand.

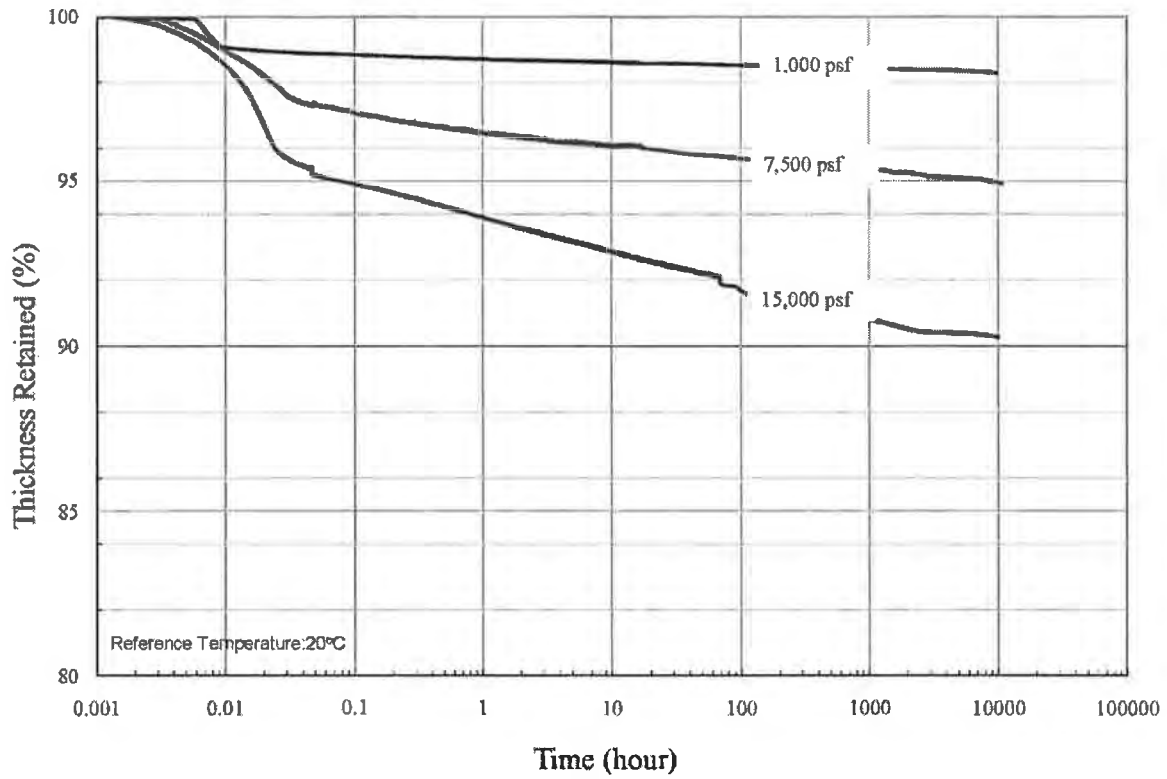

Figure B-3. Creep Curves for a 300 mil GSE HyperNet UF geonet.

Table B-3. Creep Reduction Factors for a 300 mil GSE HyperNet UF geonet from 100 hours to 50 Years.

Stress (psf)	Creep Reduction Factor
1,000	1.00
5,000	1.06
15,000	1.19

use 1.02

The long term performance of a lateral drain requires a larger initial transmissivity, θ_{LTIS} , than that obtained from the design equations, $\theta_{req'd}$. This process was initially quantified by Koerner (1998) as follows:

$$FS = \frac{\theta_{LTIS}}{\theta_{req'd}} \quad \text{Eq. 3.2}$$

$$\theta_{LTIS} = \frac{\theta_{measured}}{RF_{in} \cdot RF_{cr} \cdot RF_{cc} \cdot RF_{bc}} \quad \text{Eq. 3.3}$$

where FS is the overall safety factor for drainage, θ_{LTIS} is the long-term-in-soil hydraulic transmissivity of the drainage geocomposite, $\theta_{req'd}$ is the required transmissivity (e.g., for MTG= $3 \cdot 10^{-5} \text{ m}^3/\text{sec-m}$), $\theta_{measured}$ is the transmissivity measured in accordance with ASTM D4716, and RF are service reduction factors described as follows:

- RF_{in} = reduction factor for elastic deformation, or intrusion of the adjacent geotextiles into the drainage channel.
- RF_{cr} = reduction factor for creep deformation of the drainage core and/or adjacent geotextile into the drainage channel.
- RF_{cc} = reduction factor for chemical clogging and/or precipitation of chemicals in the drainage core space.
- RF_{bc} = reduction factor for biological clogging in the drainage core space.

Suggested empirical default values of the reduction factors are listed in Table 3.1 (Koerner, 1998). Currently, laboratory testing can be performed to evaluate RF_{in} and RF_{cr} on a site and drainage composite specific basis. Such testing is discussed in this chapter.

Table 3.1 Recommended preliminary reduction factor values for determining allowable flow rate or transmissivity of geonets (Koerner, 1998)

Application area	RF_{in}	RF_{cr}	RF_{cc}	RF_{bc}
Surface water drains for covers	1.3 - 1.5	1.1 - 1.4	1.0 - 1.2	1.2 - 1.5
Leachate Collection and Removal Systems (LCRS)	1.5 - 2.0	1.4 - 2.0	1.5 - 2.0	1.5 - 2.0
Leachate Detection Systems (LDS)	1.5 - 2.0	1.4 - 2.0	1.5 - 2.0	1.5 - 2.0

While the above total safety factors may appear to be very conservative there may be long-term service reduction factors not accounted for. For instance, Figure 3.1 shows extensive root penetration into a geonet that was recovered from a failed landfill cover. The root penetration was so dense that the transmissivity of the geonet drainage core was essentially reduced to zero. The authors feel that root penetration in cover lateral drains can be minimized only by using high capacity drainage composites that quickly remove water from the drain so that roots are not attracted within the core.

Ref:
 Richardson G.N., Giroud J.P 23 and Zhao A. (2000)
 Design of Lateral drainage ~~Systems~~ Systems for Landfills.

It is often desirable to develop a composite runoff coefficient based on the percentage of different types of surfaces in the drainage areas. Composites can be made with the values from Table 2.2 by using percentages of different land uses, as illustrated in Equation 2.2. In addition, more detailed composites can be made with coefficients for different surface types such as roofs, asphalt, and concrete streets, drives and walks. The composite procedure can be applied to an entire drainage area or to typical "sample" blocks as a guide to the selection of reasonable values of the coefficient for an entire area.

Equation 2.2 Composite C

$$\text{Composite C} = \frac{C1 \cdot A1 + C2 \cdot A2 + \dots + Cx \cdot Ax}{A1 + A2 + \dots + Ax}$$

2.2.3 Rainfall Intensity

The rainfall intensity (I) is the average rainfall rate in in./hr for a duration equal to the time of concentration for a selected return period. Once a particular return period has been selected for design and a time of concentration calculated for the drainage area, the rainfall intensity can be determined from the intensity-duration-frequency (IDF) data for the City of Raleigh given in Table 2.3.

Table 2.3 Intensity – Duration - Frequency Table

City of Raleigh, NC

(Developed by Dr. H.R. Malcom, North Carolina State University, Dept. of Civil Engineering, and the authors based on NOAA HYDRO-35 and USWB TP-40)

Intensity used when determining drainage layer capacity

Duration	Frequency (Yrs)					
	2	5	10	25	50	100
5 mins	5.76	6.58	7.22	8.19	8.96	9.72
10	4.76	5.54	6.13	7.01	7.71	8.40
15	4.04	4.74	5.25	6.03	6.64	7.24
20	3.47	4.12	4.64	5.42	5.93	6.47
30	2.70	3.28	3.71	4.32	4.80	5.28
40	2.28	2.77	3.15	3.70	4.08	4.48
50	1.94	2.38	2.71	3.19	3.53	3.88
60	1.70	2.12	2.41	2.84	3.17	3.50
90	1.22	1.52	1.74	2.06	2.29	2.53
2 hr	0.95	1.20	1.37	1.62	1.81	2.00
3	0.71	0.89	1.02	1.21	1.35	1.50
6	0.44	0.56	0.65	0.77	0.86	0.96
12	0.26	0.33	0.39	0.46	0.52	0.57
24	0.15	0.19	0.22	0.27	0.30	0.33

Project	Charah Colon Mine	Computed	MDP	Date	3/6/2015
Subject	Leachate Collection Pipes	Checked	PAW	Date	3/8/2015
Task	Leachate Pipe Sizing	Sheet	1	Of	2

Objective: Determine the time to drain under several design conditions.

Equations:

Pipe capacity (Q) = $(D/16)^{8/3} / n \cdot \sqrt{s}$ Mannings Equation $Q = C_d \cdot A \cdot (2 \cdot g \cdot h)^{0.5}$ Orifice Equation

Inside pipe diameter (D) = $16(Qn/\sqrt{s})^{3/8}$ $Q = \text{cfs, discharge}$

Inside pipe diameter (D) = $D_{\text{outside}} - 2 \cdot D_{\text{outside}} / \text{SDR}$ $C_d = 0.6$ coefficient of discharge

Std Dimension Ratio (SDR) = $D_{\text{outside}} / \text{wall thickness}$ A = sf, cross sectional area

Amount Drained = Allowable Flow/FS g = 32.2 ft/sec², gravity

Allowable Flow = Minimum of gravity flow and orifice flow under head. h = ft, driving head (above center of the pipe)

Assumptions:

Use HDPE pipe w/ SDR = 11 Pipe Size Min Factor of Safety = 1.5

Manning roughness coefficient, n = 0.009 HDPE Allowable design head on pipe = 6 feet

7.48052 gallons/cf

86,400 sec/day

Design Event 1: Peak HELP Model flowrate

Peak Leachate flow (cf/acre/day) = 1822 HELP Model analysis of Cell with 10' of fill at 3%

Largest cell, for leachate collection 29.4 acres

Peak Leachate flow 53,567 cf

Design Event 2: 25 yr storm in an open subcell

Design Storm (inches/day) = 6.28 25 yr 24 hr

Largest subcell for SW drainage 5.9 acres

Design Storm event 134,499 cf **Governing event**

Amount Drained (cf/day)	Pipe Outside Diameter (inches)						
	6.625	8.625	10.75	12.75	13.375	14	16
0.10%	11,288	22,811	41,041	64,687	73,492	83,011	118,517
0.20%	15,964	32,260	58,040	91,482	103,934	117,395	167,608
0.30%	19,552	39,510	71,085	112,042	127,293	143,779	205,277
0.40%	22,576	45,623	82,082	129,375	146,985	166,021	237,033
0.50%	25,241	51,008	91,770	144,646	164,334	185,618	265,011
0.60%	27,650	55,876	100,529	158,451	180,019	203,334	290,305
0.70%	29,866	60,353	108,584	171,147	194,443	219,626	313,566
0.80%	31,928	64,520	116,081	182,964	207,868	234,790	335,216
0.90%	33,864	68,434	123,122	194,062	220,477	249,032	355,550
1.00%	35,696	72,136	129,782	204,560	232,404	262,503	374,783
1.20%	39,103	79,021	142,169	224,084	254,585	287,558	410,554
1.40%	42,236	85,352	153,560	242,038	274,984	310,598	443,449
1.80%	47,891	96,780	174,121	274,446	311,802	352,185	502,824
2.00%	50,482	102,015	183,540	289,291	328,668	371,235	530,023
2.25%	53,544	108,204	194,673	306,840	348,606	393,755	562,174
2.50%	56,441	114,057	205,204	323,437	367,462	415,054	592,583
2.75%	59,195	119,624	215,220	339,224	385,398	435,312	598,664
3.00%	61,828	124,943	224,790	354,308	402,535	454,669	598,664
3.50%	66,781	134,954	242,800	382,696	422,609	461,919	598,664
4.00%	71,392	144,271	259,565	384,953	422,609	461,919	598,664
5.00%	79,819	161,300	275,733	384,953	422,609	461,919	598,664
6.00%	87,437	176,696	275,733	384,953	422,609	461,919	598,664
8.00%	100,964	178,906	275,733	384,953	422,609	461,919	598,664

Project	Charah Colon Mine	Computed	MDP	Date	3/6/2015
Subject	Leachate Collection Pipes	Checked	PAW	Date	3/8/2015
Task	Leachate Pipe Sizing	Sheet	2	Of	2

Pipe X-Section (sf)	0.2	0.3	0.4	0.6	0.7	0.7	0.9
	Pipe Outside Diameter (inches)						
Allowable Flow in pipe Q (cfs)	6.625	8.625	10.75	12.75	13.375	14	16
Pipe Slope							
0.10%	0.2	0.4	0.7	1.1	1.3	1.4	2.1
0.20%	0.3	0.6	1.0	1.6	1.8	2.0	2.9
0.30%	0.3	0.7	1.2	1.9	2.2	2.5	3.6
0.40%	0.4	0.8	1.4	2.2	2.6	2.9	4.1
0.50%	0.4	0.9	1.6	2.5	2.9	3.2	4.6
0.60%	0.5	1.0	1.7	2.8	3.1	3.5	5.0
0.70%	0.5	1.0	1.9	3.0	3.4	3.8	5.4
0.80%	0.6	1.1	2.0	3.2	3.6	4.1	5.8
0.90%	0.6	1.2	2.1	3.4	3.8	4.3	6.2
1.00%	0.6	1.3	2.3	3.6	4.0	4.6	6.5
1.20%	0.7	1.4	2.5	3.9	4.4	5.0	7.1
1.40%	0.7	1.5	2.7	4.2	4.8	5.4	7.7
1.80%	0.8	1.7	3.0	4.8	5.4	6.1	8.7
2.00%	0.9	1.8	3.2	5.0	5.7	6.4	9.2
2.25%	0.9	1.9	3.4	5.3	6.1	6.8	9.8
2.50%	1.0	2.0	3.6	5.6	6.4	7.2	10.3
2.75%	1.0	2.1	3.7	5.9	6.7	7.6	10.4
3.00%	1.1	2.2	3.9	6.2	7.0	7.9	10.4
3.50%	1.2	2.3	4.2	6.6	7.3	8.0	10.4
4.00%	1.2	2.5	4.5	6.7	7.3	8.0	10.4
5.00%	1.4	2.8	4.8	6.7	7.3	8.0	10.4
6.00%	1.5	3.1	4.8	6.7	7.3	8.0	10.4
8.00%	1.8	3.1	4.8	6.7	7.3	8.0	10.4

Conclusions:

Design storm generates greater amount of liquid to handle than is expected from the peak leachate production.
As the preferred minimum pipe size is 8" and the minimum pipe slope for the site is 0.5%

An 8 inch pipe with 0.5% slope can drain:

Design 1: The peak leachate flow volume will drain in 25.2 hours
Design 2: storm event volume will drain in 63.3 hours

HDR Computation

Job Number	453925-235691-018	No.
------------	-------------------	-----

Project	Charah Colon Mine	Computed	MDP	Date	3/6/2015
Subject	Permit Application	Checked	PAW	Date	3/6/2015
Task	Leachate Pipe Sizing	Sheet	1	Of	1

Objective:

Determine the required leachate collection pipe size based on drainage areas for each cell.

References:

- "Waste Containment Systems, Waste Stabilization, and Landfills; Design and Evaluation"; Hari Sharma and Sangeeta
- "Elements of Urban Stormwater Design"; H. Rooney Malcom; p. I-10

Calculations:

$$D_{REQD} = 16 \left[\frac{Qn}{\sqrt{s}} \right]^{\frac{3}{8}} \quad (\text{Ref. 2})$$

Where:

D_{REQD} = theoretical pipe diameter (in.) for just-full flow

n = Manning roughness coefficient (dimensionless)

s = longitudinal slope (ft/ft)

Q = Required flow volume to drain in 24 hrs. (cfs)

Volume (ft³) = Peak Daily Volume (ft³/acre) x Area (acre)
 Peak Daily Volume is from the HELP Model runs
 Q = Volume/time (convert to ft³/sec)

Inputs:

Peak Daily Volume* = **1822** ft³/Ac leachate collected in 24 hours
 n = **0.009** Ref. 1, Table 9.3, p. 472 (HDPE)
 * Peak Daily Volume from HELP model run for 10' ash with geocomposite as lateral drainage feature.

12 in/foot
 43,560 square feet/acre
 24 hours/day
 60 min/hour
 60 sec/min

Outputs:

Pipe Use	Area (AC)**	Volume (ft ³)	Q (ft ³ /sec)***	Minimum Slope	D_{REQD} (in)	D_{ACT} (in)	Check
Cell 1 Header	22.4	40,813	0.472	0.5%	5.6	8	ok
Cell 2 Header	15.3	27,877	0.323	0.5%	4.8	8	ok
Cell 3 Header	19.3	35,165	0.407	1.0%	4.6	8	ok
Cell 4 Header	31.9	58,122	0.673	0.5%	6.4	8	ok
Cell 5 Header	29.4	53,567	0.620	0.5%	6.2	8	ok

** Denotes maximum drainage area for all laterals.

*** Assumes the entire area will be drained in a 24 hour period

Conclusion: 8-inch pipe has adequate capacity at the design pipe slopes for the peak flow predicted by the HELP Model.

This page intentionally left blank.

HDR Computation

		Job Number		No.
Project	Charah Colon Mine	Computed	MDP	Date 11/6/2014
Subject	Permit Application	Checked	KP	Date 11/6/2014
Task	Leachate Pipe Stresses - Static	Sheet	1	Of 1

Objective: Determine the leachate collection pipe stresses due to static (overburden) and dynamic (equipment) loads.

- References:**
1. "Polyethylene Piping Systems Manual" by Driscopipe
 2. "Waste Containment Systems, Waste Stabilization, and Landfills: Design and Evaluation" by Hari D. Sharma and Sangeeta P. Lewis, 1994
 3. "An Introduction to Geotechnical Engineering" by Holtz & Kovacs

Calculations:

STATIC LOADS

Wall Crushing

$$S_A = \frac{P_T(\text{SDR}-1)}{2} \quad \text{Ref. 1}$$

$$FS = \frac{1,500 \text{ psi}}{S_A} \quad \text{Ref. 1}$$

Goal FS ≥ 1.8

Where:

S_A = Actual compressive stress (psi)

SDR = Standard Dimension Ratio

P_T = Total external pressure on the top of the pipe (psi)

1,500 psi = Compressive yield strength of HDPE pipe

Overburden:	Thickness (ft)	Unit Weight (lb/ft ³)
CCR:	90	75 Riverbend (56.6 pcf)
Vegetative Cover Layer:	6	120

Maximum Vertical Stress, P_T = 52 psi

SDR	S _A (psi)	FS	Comment
26.0	648.4	2.31	Okay
21.0	518.8	2.89	Okay
17.0	415.0	3.61	Okay
11.0	259.4	5.78	Okay

Wall Buckling

$$P_C = \frac{2.32E}{\text{SDR}^3}$$

Ref. 1

Where:

P_C = Hydrostatic, critical-collapse differential pressure (psi)

E = Stress and time dependent tensile modulus of elasticity (psi)
(approximately 35,000 psi)

$$P_{CB} = 0.8\sqrt{E'P_C}$$

Ref. 1

P_{CB} = Critical buckling soil pressure at the top of the pipe (psi)

E' = Soil Modulus (psi)

$$FS = \frac{P_{CB}}{P_T}$$

Ref. 1

Goal FS ≥ 2.0

Ref. 2

SDR	E (psi)	P _C (psi)	E' (psi)	P _{CB} (psi)	FS	Comment
26.0	35,000	4.62	1,500	66.60	1.28	Below criteria
21.0	35,000	8.77	1,500	91.75	1.77	Below criteria
17.0	35,000	16.53	1,500	125.96	2.43	Okay
11.0	35,000	61.01	1,500	242.01	4.67	Okay

SDR 17 meets the minimum static load criteria

HDR Computation

Job Number	No.
------------	-----

Project	Charah Colon Mine	Computed	MDP	Date	11/6/2014
Subject	Drainage Calculations	Checked	KP	Date	11/6/2014
Task	Leachate Pipe Stresses - Dynamic	Sheet	1	Of	1

Calculations:

Use SDR **11** from crushing and buckling analysis

DYNAMIC LOADS (Minimum Factor of Safety = 1.4)

Point Loads

$$P_P = \frac{3WZ^3}{2\pi Z^5}$$

Ref. 1

Where:

P_P = Point Load (psi)

W = 1.5 x Superimposed surface load (lb)

Z = to top of pipe (ft)

Minimum Cover Soil = **8** ft

Equipment	Weight (lbs)	Number of Tires	P_P (psi)	S_A (psi)	FS	Comment
950 Wheel Loader	48,628	4	136.0	680.2	2.21	Okay
627F Scraper	128,550	4	359.6	1798.2	0.83	No Good
621 Scraper	118,700	4	332.1	1660.4	0.90	No Good
815B Compactor	44,175	4	123.6	617.9	2.43	Okay
825C Compactor	71,429	4	199.8	999.2	1.50	Okay

Line Loads:

$$P_L = \frac{2WZ^3}{\pi Z^4}$$

Ref. 3

Where:

P_L = Line Load (psi)

W = 1.5 x Superimposed surface load (lb)

Z = to top of pipe (ft)

Minimum Cover Soil = **1.75** ft

Equipment	Weight (lbs)	Track Length (ft)	P_L (psi)	S_A (psi)	FS	Comment
D4H LGP (III) Bulldozer	27,500	8.58	72.9	364.4	4.12	Okay
D6H LGP (II) Bulldozer	45,400	10.67	96.7	483.7	3.10	Okay
D9R Bulldozer	106,538	11.50	210.6	1053.2	1.42	Okay
953 Track Loader	37,560	7.50	113.9	569.3	2.63	Okay
963 Track Loader	48,914	8.08	137.6	688.2	2.18	Okay

HDR Computation

Job Number	453925-235691-018	No.
-------------------	-------------------	------------

Project: Charah Colon Mine	Computed	MDP	Date: 3/6/2015
Subject: Permit Application	Checked	PAW	Date: 3/8/2015
Task: Leachate Pipe Orifice Sizing	Sheet:	1	Of 2

Objective: Determine if the leachate pipes and perforations are large enough to handle the peak daily leachate flow.

References:

1. Malcom, H. Rooney (1989). *Elements of Urban Stormwater Design*. Raleigh: NC State Univ.
2. Sharma, H. D., & Lewis, S. P. (1994). *Waste Containment Systems, Waste Stabilization, and Landfills: Design and Evaluation*. New York: John Wiley & Sons, Inc.

Calculations:

Eq. 1	$Q = C_d A \sqrt{2gh}$	Reference 1	<u>Conversion factors</u>
			7.48 gal/cf
			60 s/min
			60 min/hr
			24 hr/day
Eq. 2	$A = \pi \left(\frac{d}{2} \right)^2$		12 in/ft
			43,560 sf/acre

Where:

- Q = Flow Rate (cfs)
- C_d = Coefficient of Discharge (dimensionless)
- A = Cross-sectional Area of Orifice (sf)
- g = gravity (ft/s²)
- h = head (ft)
- d = diameter of opening (ft)

Given:

Select the Flow Rate per Acre based on HELP model runs

Q_{peak daily} = 1822.00 cf/acre/day From HELP model run: 10' of ash
 Q_{peak daily} = 9.46 gal/acre/min

SDR	Pipe Size (inches)
11	8

Maximum Drainage distance =	950 feet
Area of Drainage per foot of pipe =	950 sf
Area of Drainage per foot of pipe =	0.022 ac
Required Drainage per foot of pipe =	0.206 gpm (actual flow rate per acre for the drainage area of the pipe)

Determine the maximum allowable flow in the pipe based on the perforations in the pipe and a maximum head

Diameter of perforation, d_{perforation} = 0.375 in
 d_{perforation} = 0.03125 ft
 A_{perforation} = 0.00077 ft²

Using Equation 1, determine the flow in the pipe

C _d =	0.6 typical default value (Ref. 1)	
A _{perforation} =	0.00077 ft ²	
g =	32.2 ft/s ²	
h =	8 in	The maximum head on the liner is 12 inches. The pipe is 8 inches in diameter.
h =	0.67 ft	The head was therefore assumed to be from the center of the pipe to 12 inches above the liner.
Q _{perforation} =	0.003 cfs	
Q _{perforation} =	1.35 gpm per perforation	
Number of Perforations per foot of pipe =	30 perforations per foot of pipe	
Q_{per foot of pipe} =	40.60 gpm	

HDR Computation

Job Number 453925-235691-018 No.

Project: Charah Colon Mine	Computed MDP	Date: 3/6/2015
Subject: Permit Application	Checked PAW	Date: 3/8/2015
Task: Leachate Pipe Orifice Sizing	Sheet: 2	Of 2

Required Flow Rate **Allowable Flow Rate**
 gpm < gpm
 0.206 40.60

Conclusion:
 The allowable flow rate is greater than the required flow rate. Therefore the allowable flow rate based on pipe perforations will be sufficient to meet the actual expected flow rate.

Determine the maximum allowable flow in the pipe based on the pipe size and flowing full

Eq. 3
$$Q = \left(\frac{D}{16} \right)^{\frac{8}{3}} \frac{\sqrt{s}}{n}$$
 Reference 1

Where: Q = Flow Rate (cfs)
 D = Theoretical Pipe Diameter (in) for just-full flow
 n = Manning roughness coefficient (dimensionless)
 s = Longitudinal slope (ft/ft)

D = 8 in
 n = 0.009 Reference 2, page 472

Slope	Allowable Q (cfs)	Allowable Q (gpm)	Check
0.10%	0.55	248	Allowable Q is greater than Required Q
0.25%	0.87	393	Allowable Q is greater than Required Q
0.50%	1.24	555	Allowable Q is greater than Required Q
0.75%	1.52	680	Allowable Q is greater than Required Q
1.00%	1.75	785	Allowable Q is greater than Required Q
1.25%	1.96	878	Allowable Q is greater than Required Q
1.50%	2.14	962	Allowable Q is greater than Required Q
1.75%	2.31	1,039	Allowable Q is greater than Required Q
2.00%	2.47	1,111	Allowable Q is greater than Required Q
2.25%	2.62	1,178	Allowable Q is greater than Required Q
2.50%	2.77	1,242	Allowable Q is greater than Required Q
2.75%	2.90	1,302	Allowable Q is greater than Required Q
3.00%	3.03	1,360	Allowable Q is greater than Required Q
3.25%	3.15	1,416	Allowable Q is greater than Required Q
3.50%	3.27	1,469	Allowable Q is greater than Required Q
3.75%	3.39	1,521	Allowable Q is greater than Required Q

Conclusion:
 The allowable flow rate is greater than the required flow rate for slopes 0.1% and above. Smaller pipe slopes were not run, but it is assumed that the bottom slope will not be smaller than 0.25% accounting for settlement. Therefore the allowable flow based on pipe size will be sufficient to meet the actual expected flow rate.

HDR Computation

Job Number

453925-235691-018

Project:	Charah Colon Mine	Computed:	MDP	Date:	3/6/2015
Subject:	Permit Application	Checked:	PAW	Date:	3/8/2015
Task:	Leachate Pipe Perforations	Sheet	1	Of	1

Objective Determine the perforations in the collection pipes
Ensure that pipe perforations are sufficient for pipe flows

Equations

$$Q = C_d * A (2 * g * h)^{0.5} \quad \text{Orifice Equation}$$

$C_d = 0.6$ Typical Default value 7.84052 gals/cf
 $g = 32.2$ ft/sec², gravity 60 sec/min
 $A = sf$, cross sectional area of pipe 86400 sec/day
 $h = ft$, driving head

HELP Model Avg Annual Lateral Drainage Collected 78,144.0 cf/yr/ac 0.002 cfs/acre
 HELP Model Peak Daily Lateral Drainage Collected 1,822.0 cf/day/ac 0.021 cfs/acre

Calculations

Check Inlet Control of perforations for pipe under peak condition

Basis	Area to Drain (Acres)	Q (cfs)	Pipe Diameter (in)	# of holes per ft of pipe	Hole Diameter (in)	Length (ft)	Inlet Cross Sectional Area (sf)	Required Head to fill pipe, h (in)	Depth of liquid @ pipe (in)
Entire Site	118.7	2.50	8	30	3/8	28	0.6	7.8	11.8
Largest Cell	29.4	0.62	8	30	3/8	7	0.2	7.7	11.7
Largest Subcell	6.0	0.13	8	30	3/8	2	0.0	3.9	7.9

Only 12 inch depth of liquid is required to fill the pipe at the design flow rate, assuming liquid is available

Conclusion There is adequate redundancy in pipe perforations to handle expected flows.

This page intentionally left blank.

Determination of Leachate Collection Pipe Capacity

Subject: Leachate Collection Pipe Flow Capacity for Colon Mine Site

Scope

Evaluate the maximum flow capacity of the leachate collection lines.

References

1. Merritt, F.S., Standard Handbook for Civil Engineers, 3rd Ed., McGraw-Hill, New York, 1983.
2. CP Chem Performance Pipe "Municipal & Industrial Series/IPS Pipe Data," May 2001.

Basis

- The leachate collection pipes are proposed to consist of 8-inch diameter SDR-11 HDPE pipes. The 8-inch pipes have a nominal outer diameter (OD) equal to 8.625-inches and an average inner diameter (ID) equal to 6.963-inches. The pipes must have adequate flow capacity to transport the leachate to the sumps. The flow capacity should be compared to the maximum amount of leachate expected to be generated.
- Expected leachate flow rates were determined by using the Hydrologic Evaluation of Landfill Performance (HELP) program and a 25-year, 24-hour design storm.

Results

Leachate collection and conveyance system should be designed based on 8-inch diameter SDR 11 HDPE pipe.

Analysis

LEACHATE COLLECTION PIPE DESIGN BASED ON PEAK LEACHATE GENERATION RATE

The leachate collection pipe system capacity analysis is based upon the cell layout and leachate collection pipe layout shown on the top of liner sheets. The leachate generation rate used to size the leachate collection pipes was based on a HELP run consisting of 5 - 2 ft coal combustion product (CCP) layers. The following parameters were also entered into the HELP model.

- No recirculation.
- Open cell conditions.
- The initial moisture content at 31%.
- Drainage length was determined at varying floor slopes from 0.5 to 3%. The leachate collection system has been designed to meet this requirement.

The results of the HELP run predict that the peak daily drainage discharging from CCP is 1,822 cf/acre (9.46 gpm per acre). The largest area draining to a leachate collection pipe is 29.4 acres. Using a maximum generation rate of 9.46 gpm per acre and an area of 29.4 acres, the total flow rate to a collection pipe is 278.1 gpm.

$$Q_{\text{peak day avg}} = 278.1 \text{ gpm}$$

The following analysis illustrates the capacity of the 8-inch leachate collection lines in relationship to slope.

Manning's coefficient for HDPE pipe (n) is 0.009

The spreadsheet below calculates flow capacity in gpm based on Manning's Equation for HDPE pipes.

$$Q_p = (1.49/n) A(R_H^{2/3})S^{0.5}$$

where: Q_p = pipe capacity (gpm)
n = Manning's roughness coefficient
R_H = hydraulic radius
A = pipe cross-sectional area
S = slope of the pipe

Full Pipe Flow at Varying Slope									
Manning's Formula									
Q=1.49/n*Rh ^{2/3} *A*s ^{1/2}									
	6-inch SDR 11	6-inch SDR 11	8-inch SDR 11	8-inch SDR 11	10-inch SDR 11	10-inch SDR 11	12-inch SDR 11	12-inch SDR 11	
I.D. (in.)	5.349	5.349	6.963	6.963	8.679	8.679	10.293	10.293	
Slope (ft/ft)	Q _p (gpm)	V _p (fps)	Q _p (gpm)	V _p (fps)	Q _p (gpm)	V _p (fps)	Q _p (gpm)	V _p (fps)	
0	0.0	0.0	0.0	0.0	0.0	0.0	0.0	0.0	n = 0.009 for HDPE Pipe Rh/D = 0.25 for full flow
0.005	189.9	2.7	383.6	3.2	690.2	3.7	1087.7	4.2	
0.01	268.5	3.8	542.4	4.6	976.1	5.3	1538.2	5.9	
0.015	328.9	4.7	664.4	5.6	1195.4	6.5	1883.9	7.3	
0.02	379.7	5.4	767.1	6.5	1380.4	7.5	2175.3	8.4	

As shown in the above table, an HDPE SDR-11, 8-inch pipe with an average inner diameter equal to 6.963-inch at a minimum slope of 0.5% has a capacity of 383 gpm. Therefore, an 8-inch pipe can accommodate the maximum leachate generation rate from the 29.4 acre maximum drainage area at the Colon Mine Site.

ANALYSIS BASED ON LEACHATE/STORMWATER COLLECTION:

For initial stormwater/leachate drainage, assuming 6.28 inch depth in 24-hr 25-year storm event for Raleigh, NC, approximately 22,796 cf/ac/day of stormwater is collected. Total volume of stormwater/leachate collected within the largest (5.9 acre) subcell is 134,495 cf.

An 8-inch diameter pipe with 0.5% slope can convey 383 gpm. Considering a FS of 1.5 (meaning that the pipe is partially occluded), the pipe capacity is 255.3 gpm. Accordingly, a 136,778 cf (1,023,099 gallons) of storage volume will be emptied in approximately 67 hours assuming no other rain events during that period.

ANALYSIS FOR SOLID WALL LEACHATE CONVEYANCE PIPE:

The header is designed based on the leachate generated from largest drainage area. The largest area draining to a header pipe is approximately 29.4 acres. At 1,822 cf/day generation rate, the header is sufficient to handle the required flow.

For the Raleigh area the design rainfall depths and runoff depths for the 24 hour design storm are as follows:

Table 2-5 Runoff Depth for Raleigh (in)

24 hours storm with $I_a = 0.2 \cdot S$

Frequency, yr	2	5	10	25	50	100
Rainfall, in	3.60	4.56	5.28	6.48	7.2	8.0
CN 60	0.58	1.05	1.47	2.24	2.75	3.33
65	0.81	1.37	1.84	2.71	3.26	3.89
70	1.07	1.72	2.25	3.19	3.79	4.46
75	1.37	2.10	2.68	3.69	4.33	5.04
80	1.72	2.51	3.14	4.22	4.88	5.63
85	2.10	2.96	3.63	4.76	5.44	6.21
90	2.54	3.45	4.15	5.31	6.02	6.81
95	3.04	3.98	4.70	5.89	6.60	7.40
98	3.37	4.32	5.04	6.24	6.96	7.76

The CN is used to determine the initial abstraction, I_a , in Table 2-6. I_a/P is then computed using Figure 2.6.

PERFORMANCE ADVANTAGES OF DRISCOPEX® 4000/4100 PIPE

Stripes

Stripes allow easy field identification of pipe. DriscoPlex® 4000 (DIPS) pipe comes standard with three pairs of blue stripe, but lavender, green, and no stripes is optional. The standard DriscoPlex® 4100 (IPS) is black, but blue, lavender and green striping is optional with 4 single stripes at 90 degrees apart.

Flow

DriscoPlex® 4000/4100 pipes are characterized as hydraulically smooth and typically have an absolute surface roughness (ϵ) of 0.000005 ft. The Hazen-Williams Friction Factor (C) equals 150 to 155 for polyethylene pipes. Even though the inside diameter of polyethylene pipe may be smaller for the same nominal size as metallic or concrete pipes, flow is often equal or greater through polyethylene pipe. For example, an 8" DR17 DriscoPlex® 4000 pipe has a lower pressure drop per given flow rate than an 8" CL350 concrete lined DI pipe (C equals 120). For gravity flow, the n-factor in the Manning equation is typically taken as 0.009 for clear water and 0.010 for sanitary sewer. For design information, see the *Handbook of Polyethylene Pipe*, Chapter 6.



Surge Pressure

When it comes to surges, polyethylene has two advantages over most piping materials. 1) As Table 3 shows, it has the capacity to handle surge pressures significantly in excess of its pressure rating. 2) It also has the lowest surge pressure of all common water pipes. For example, a 5 ft/sec velocity change in a DR17 Polyethylene pipe will produce a 56 psi surge, in a DR18 PVC pipe the surge is 88 psi, and in a Class 50 DI pipe the surge is 268 psi. Thus, with polyethylene pipe there are lower surge pressures and less wear and tear on valves, hydrants, and other system components and, when surges occur, HDPE pipes may be quite capable of handling them with a lower Pressure Class (PC) than required for other materials.

Fatigue

Repeated surges will cause fatigue stress in pipelines. This is particularly significant in certain thermoplastic pipes, excluding polyethylene. Fortunately, polyethylene has an excellent resistance to fatigue. The projected design life for DriscoPlex® 4000/4100 pipes exceeds 100 years for pipe operating at a velocity of 4 fps with a surge frequency of 4 times per hour continuously. See Bulletin [PP-402, Working Pressure Rating and Fatigue Life](#).

Comparison with Other Piping Products

Polyethylene's superior performance is due to its fused joint, toughness, and flexibility. Comparisons of polyethylene to other piping materials based on PC alone can lead to costly over-designs, since the definition of "Pressure Class" varies from material to material (see AWWA C906, C905, etc). When correctly incorporating HDPE's lower surge magnitudes, higher surge allowances, and greater fatigue strength into the design, the PC required for HDPE may be much lower than the PC required for other pipe materials.

HDR Computation

Project Charah Colon Mine
 Subject Permit Application
 Task Leachate Tank Sizing

Computed MDP Date 3/6/2015
 Checked PAW Date 3/8/2015
 Sheet 1 of 1

Given: Determine Tank sizing options based on the required storage capacity
 Tank sizes selected from attached chart for Aquastore Tanks.

Require:
 0.5 feet of freeboard in tanks
 110% Capacity of primary for secondary containment tank
 Secondary tank must provide sufficient space to evaluate primary tank condition.

Evaluate the details of providing the original scenario and review viable alternatives.

Scenario	Primary		Number Primary Tanks	Primary		Primary Capacity (gals/tank)	Secondary Capacity Required (Gals)	Secondary		Secondary Tank Footprint (sf)	Secondary		Secondary Capacity Provided (gals)	110% of Primary Tank Capacity?	Total Tank Sidewall Area (sf)	Total Operating Capacity (gals)	Est. Space around tanks
	Diameter (ft)	Primary Height (ft)		Footprint (sf/tank)	Sidewall Area (sf/tank)			Secondary Diameter (ft)	Secondary Height (ft)		Sidewall Area (sf)						
1	72.73	33.01	1	4,154	7542	1,010,336	1,111,370	103.5	23.84	8,413	7,752	1,468,937	Yes	15294	1,010,336	15.4	
2	75.53	33.01	1	4,481	7833	1,089,626	1,198,589	103.5	23.84	8,413	7,752	1,468,937	Yes	15584	1,089,626	14.0	
3	78.32	28.43	1	4,818	6995	1,006,556	1,107,212	103.5	23.84	8,413	7,752	1,468,937	Yes	14747	1,006,556	12.6	
4	81.12	28.43	1	5,168	7245	1,079,813	1,187,794	103.5	23.84	8,413	7,752	1,468,937	Yes	14997	1,079,813	11.2	
5	83.92	28.43	1	5,531	7495	1,155,643	1,271,207	103.5	23.84	8,413	7,752	1,468,937	Yes	15247	1,155,643	9.8	
6	86.72	23.84	1	5,906	6495	1,031,243	1,134,367	103.5	23.84	8,413	7,752	1,468,937	Yes	14247	1,031,243	8.4	
7	89.51	23.84	1	6,293	6704	1,098,666	1,208,532	103.5	23.84	8,413	7,752	1,468,937	Yes	14456	1,098,666	7.0	
8	92.31	23.84	1	6,692	6914	1,168,477	1,285,324	160	10	20,106	5,027	1,428,845	Yes	11940	1,168,477	33.8	
9	67.13	19.28	2	3,539	4066	497,222	546,944	150	10	17,671	4,712	1,004,298	Yes	12845	994,444	5.2	
10	69.93	19.28	2	3,841	4236	539,566	593,522	150	10	17,671	4,712	982,878	Yes	13184	1,079,131	3.4	
11	72.73	19.28	2	4,154	4405	583,639	642,003	150	10	17,671	4,712	960,583	Yes	13523	1,167,278	1.5	
12	78.32	14.68	2	4,818	3612	511,026	562,129	175	10	24,053	5,498	1,366,946	Yes	12722	1,022,053	6.1	

Calculate Tank Storage Capacity (amount of event that fits in tank assuming no other flows and empty tank at start)

Site	Event		Largest Subcell Area (acres)	Gallons Produced
Colon	Rainfall 25-year 24-hr storm	6.28 inches	5.9	1,006,051
Colon	Leachate Max Avg Annual generation	78144 cf/acre	5.9	584,517

Conclusion: Select primary and secondary tanks scenario to provide for approximate operating capacity of 1,000,000 gallons. Scenario 3 and 12 would meet the required operating capacity for the 25 year storm event. Cost analysis has not been included in these calculations.

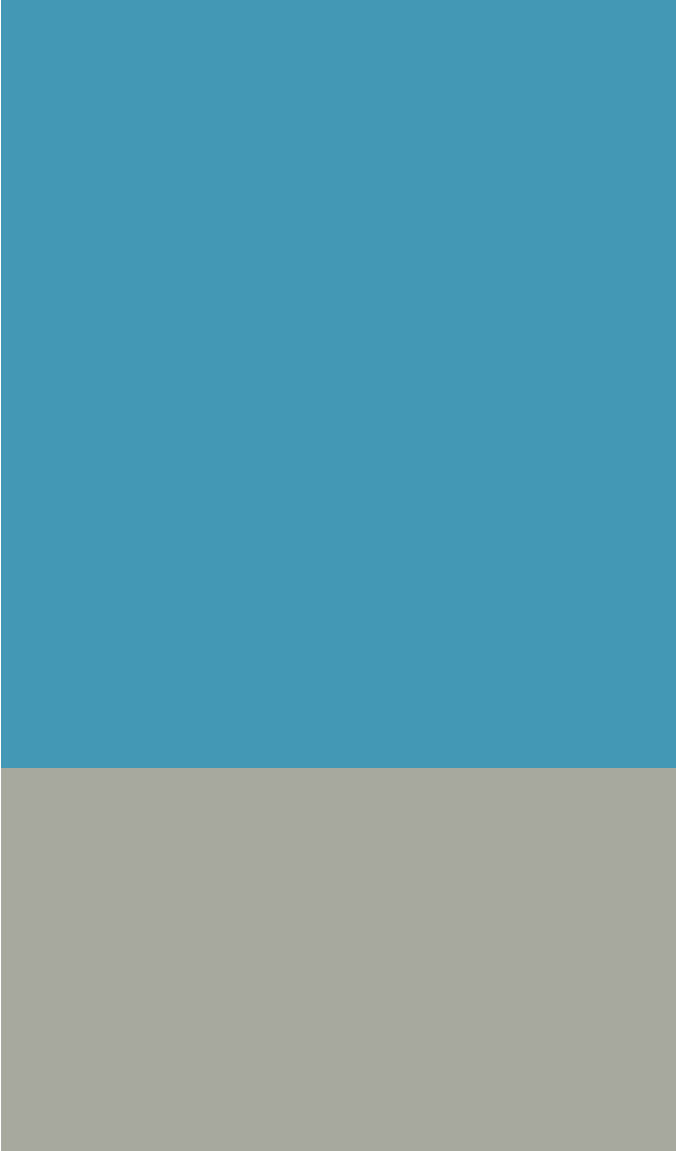

E

Stormwater

Subcell Divider Berms
Stormwater Pipe Perforations and Sizing
Stormwater Management System
Sediment Basins

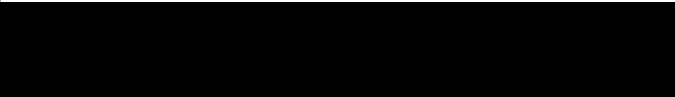



This page intentionally left blank.

HDR Computation

Job Number	453925-235691-018	No.
------------	-------------------	-----

Project	Charah Colon Mine	Computed	MDP	Date	3/5/2015
Subject	Permit Application	Checked	PAW	Date	3/8/2015
Task	Subcell Divider Berms	Sheet	1	Of	1

Objective: Determine if the subcell berms are large enough to handle a 25-year, 24-hour storm event.

References:

1. NC Erosion and Sediment Control Planning and Design Manual.

Given:

6.28 in, 25-year, 24-hour precipitation event (Raleigh, NC) Ref 1

$$V_R = A \times \frac{43,560 \text{ ft}^2}{\text{acre}} \times p \times \frac{12 \text{ in}}{\text{ft}}$$

$$V = \frac{1}{3} hA$$

Where:

V_R = Precipitation event volume (ft³)
 A = Area (acres)
 p = precipitation event (in)

V = Volume of Pond (pyramid) (ft³)
 h = Height of the berm (pyramid) (ft)
 A = Area of ponding (pyramid base) (ft²)

Case 1: Will Subcell Divider Berm handle precipitation into one subcell?

Subcell	Subcell Area (acres)	Required Volume (ft ³)	Berm Height (ft)	Area of ponding behind berm (sf)	Area of Ponding (acres)	Available Volume (ft ³)	Factor of Safety	Check
1A	5.8	132,219	4	196,710	4.52	262,280	2.0	OK
1B	5.7	129,939	4	149,607	3.43	199,476	1.5	OK
1C	5.5	125,380	4	164,101	3.77	218,802	1.7	OK
1D	5.6	127,660	8	77,152	1.77	205,739	1.6	OK
2A	5.0	113,982	5	80,998	1.86	134,997	1.2	OK
2B	5.1	116,262	5	77,584	1.78	129,306	1.1	OK
2C	5.2	118,541	5	137,167	3.15	228,612	1.9	OK
3A	4.9	111,702	8	73,538	1.69	196,101	1.8	OK
3B	4.9	111,702	8	54,946	1.26	146,521	1.3	OK
3C	4.8	109,423	7	73,368	1.68	171,191	1.6	OK
3D	4.7	107,143	5	75,723	1.74	126,204	1.2	OK
4A	5.5	125,380	4	119,310	2.74	159,080	1.3	OK
4B	5.7	129,939	6	69,575	1.60	139,150	1.1	OK
4C	5.0	113,982	6	63,507	1.46	127,013	1.1	OK
4D	5.5	125,380	8	70,683	1.62	188,488	1.5	OK
4E	5.4	123,101	8	68,510	1.57	182,692	1.5	OK
4F	4.7	107,143	8	48,898	1.12	130,395	1.2	OK
5A	5.9	134,499	8	76,860	1.76	204,961	1.5	OK
5B	5.9	134,499	8	70,705	1.62	188,548	1.4	OK
5C	5.9	134,499	7	57,921	1.33	135,148	1.0	OK
5D	5.9	134,499	5	130,176	2.99	216,961	1.6	OK
5E	5.8	132,219	6	75,553	1.73	151,106	1.1	OK

Conclusion:

All individual subcells can contain the design storm event.
 1 ft should be added to the Berm Height to maintain freeboard.

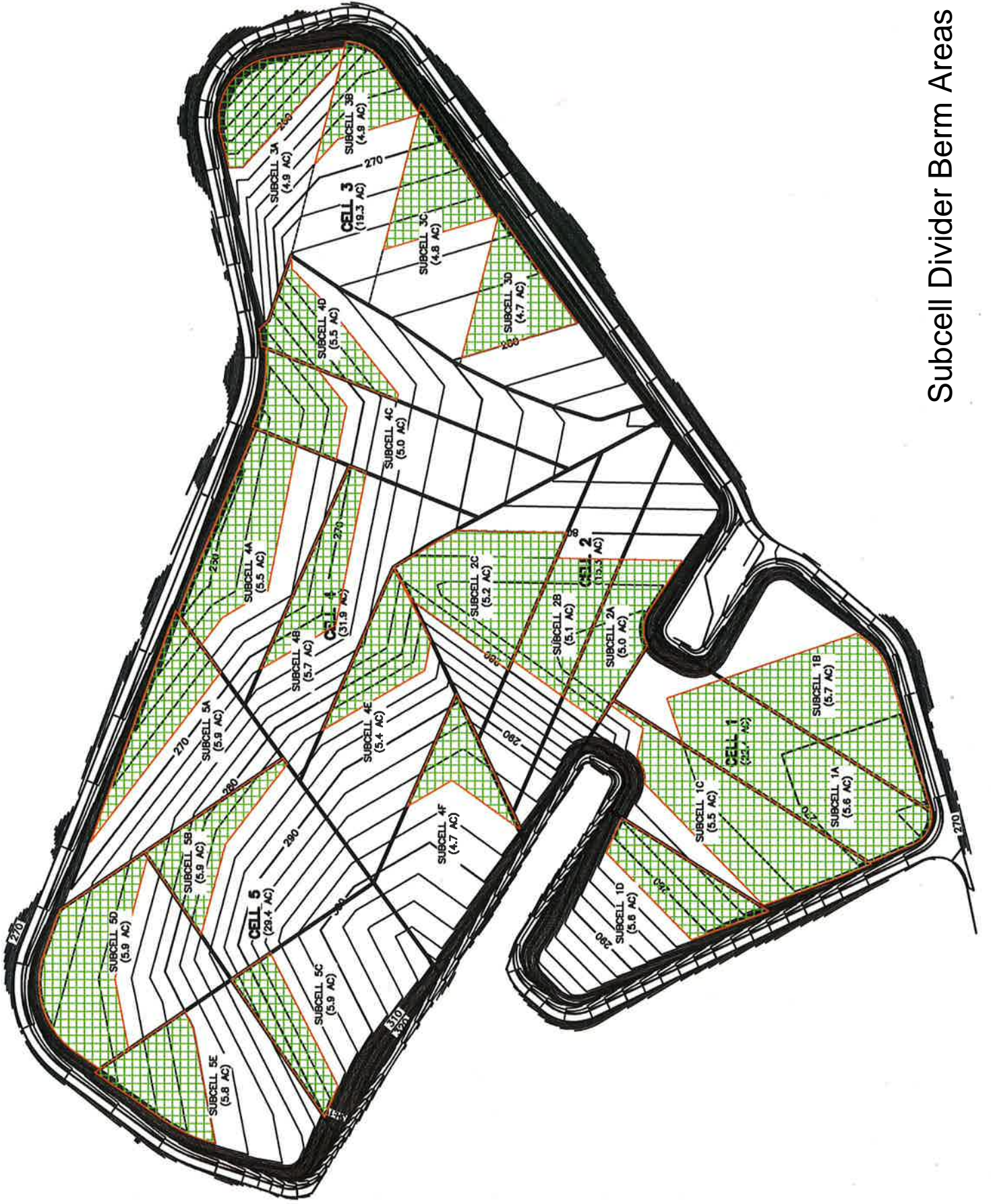

Subcell Divider Berm Areas

HDR Computation

Job Number		453925-235691-018	No.		
Project	Charah Colon Mine	Computed	MDP	Date	12/30/2014
Subject	Permit Application	Checked	EAW	Date	12/31/2014
Task	Stormwater Pipe Perforations and Sizings		1	Of	3

Objective: Determine if the leachate pipes and perforations are large enough to handle the 10 year 24 hour storm event.

References:

1. Malcom, H. Rooney (1989). *Elements of Urban Stormwater Design* . Raleigh: NC State Univ.
2. Sharma, H. D., & Lewis, S. P. (1994). *Waste Containment Systems, Waste Stabilization, and Landfills: Design and Evaluation* . New York: John Wiley & Sons, Inc.

Calculations:

Eq. 1
$$Q = C_d A \sqrt{2gh}$$
 Reference 1

Where:

- Q = Flow Rate (cfs)
- C_d = Coefficient of Discharge (dimensionless)
- A = Cross-sectional Area of Orifice
- g = gravity (ft/s²)
- h = head (ft)

- 7.48 gal/cf 12 in/ft
- 60 s/min 43,560 sf/acre
- 60 min/hr
- 24 hr/day

Determine the actual Flow Rate per Acre based on HELP model runs

- Intensity_{10yr,24hr} = 5.62 inches
- Maximum Subcell Size = 15.3 acres
- Storm Event Q_{cfs} = 312,129 cf/acre/day
- Q_{gpm} = 1621.45 gal/acre/min

- Maximum Drainage distance = 950 feet
- Area of Drainage per foot of pipe = 950 sf
- Area of Drainage per foot of pipe = 0.022 ac
- Required Drainage per foot of pipe = 35.362 gpm (actual flow rate per acre for the drainage area of the pipe)**

HDR Computation

Job Number 453925-235691-018		No.
Project Charah Colon Mine	Computed MDP	Date 12/30/2014
Subject Permit Application	Checked EAW	Date 12/31/2014
Task Stormwater Pipe Perforations and Sizings	2	Of 3

Determine the maximum allowable flow in the pipe based on the perforations into the pipe and a maximum head

$$\begin{aligned} \text{Diameter of perforation, } d_{\text{perforation}} &= 0.375 \text{ in} \\ d_{\text{perforation}} &= 0.03125 \text{ ft} \end{aligned}$$

Eq. 2

$$A = \pi \left(\frac{d}{2} \right)^2$$

$$A_{\text{perforation}} = 0.00077 \text{ ft}^2$$

Using Equation 1, determine the flow in the pipe

$$\begin{aligned} C_d &= 0.6 \text{ typical default value (Ref. 1)} \\ A_{\text{perforation}} &= 0.00077 \text{ ft}^2 \\ g &= 32.2 \text{ ft/s}^2 \\ h &= 8 \text{ in} && \text{The pipe is 8 inches in diameter. The head was} \\ &&& \text{assumed to be from the center of the pipe to 12} \\ h &= 0.67 \text{ ft} && \text{inches above the liner.} \\ Q_{\text{perforation}} &= 0.003 \text{ cfs} \\ Q_{\text{perforation}} &= 1.35 \text{ gpm per perforation} \\ \text{Number of Perforations per foot of pipe} &= 30 \text{ perforations per foot of pipe} \\ Q_{\text{per foot of pipe}} &= 40.60 \text{ gpm} \end{aligned}$$

Required Flow Rate	<	Allowable Flow Rate
gpm		gpm
35.362		40.60

Conclusion:
The allowable flow rate is greater than the required flow rate. Therefore the allowable flow rate based on pipe perforations will be sufficient to meet the actual expected flow rate. Sufficient volume can get into the pipe through the orifices.

HDR Computation

Job Number	453925-235691-018	No.	
Project	Charah Colon Mine	Computed	MDP
Subject	Permit Application	Checked	EAW
Task	Stormwater Pipe Perforations and Sizings		3
		Date	12/30/2014
		Date	12/31/2014
		Of	3

Determine the maximum allowable flow in the pipe based on the pipe size and flowing full

Eq. 3
$$Q = \left(\frac{D}{16} \right)^{\frac{8}{3}} \frac{\sqrt{s}}{n}$$
 Reference 1

Where:

Q = Flow Rate (cfs)
 D = Theoretical Pipe Diameter (in) for just-full flow
 n = Manning roughness coefficient (dimensionless)
 s = Longitudinal slope (ft/ft)

D = 8 in
 n = 0.009 Reference 2, page 472

Slope	Allowable Q (cfs)	Allowable Q (gpm)	Check
0.10%	0.55	248	Allowable Q is greater than Required Q
0.25%	0.87	393	Allowable Q is greater than Required Q
0.50%	1.24	555	Allowable Q is greater than Required Q
0.75%	1.52	680	Allowable Q is greater than Required Q
1.00%	1.75	785	Allowable Q is greater than Required Q
1.25%	1.96	878	Allowable Q is greater than Required Q
1.50%	2.14	962	Allowable Q is greater than Required Q
1.75%	2.31	1,039	Allowable Q is greater than Required Q
2.00%	2.47	1,111	Allowable Q is greater than Required Q
2.25%	2.62	1,178	Allowable Q is greater than Required Q
2.50%	2.77	1,242	Allowable Q is greater than Required Q
2.75%	2.90	1,302	Allowable Q is greater than Required Q
3.00%	3.03	1,360	Allowable Q is greater than Required Q
3.25%	3.15	1,416	Allowable Q is greater than Required Q
3.50%	3.27	1,469	Allowable Q is greater than Required Q
3.75%	3.39	1,521	Allowable Q is greater than Required Q

Conclusion:

The allowable flow rate is greater than the required flow rate for slopes 0.1% and above. Smaller pipe slopes were not run, but it is assumed that the bottom slope will not be smaller than 2% accounting for settlement. Therefore the allowable flow based on pipe size will be sufficient to meet the actual expected flow rate.

This page intentionally left blank.

HDR Computation

I Job No. 453925-235691-018 I

Project:	Charah Colon Mine	Computed	PAW	Date	11/3/14
Subject:	Permit Application	Checked	EAW	Date	11/6/2014
Task:	Drainage - Time of Concentration	Sheet	1	Of	1

Objective Determine the Time of Concentration based on the proposed top of fill grades.

References

1. "Elements of Urban Stormwater Design" by H. Rooney Malcom, P.E.

Equations

Time of Concentration, (t_c) is the longest time of flow from points on the watershed ridge to the outlet of the watershed.

$$t_c = \frac{[L^3 / H]^{0.385}}{128}$$

Time of Concentration, (min) = t_c
Hydraulic length of watershed, (ft) = L
Elevation change along length, (ft) = H

Cells 2-5

Flow Path 1
Hydraulic length of watershed L (ft) = 1,371
Peak Elevation of watershed (ft) = 330
Low Elevation of watershed (ft) = 260
Elevation change along length H (ft) = 70
 t_c (min) = 6.4

Flow Path 2
Hydraulic length of watershed L (ft) = 3,449
Peak Elevation of watershed (ft) = 328
Low Elevation of watershed (ft) = 268
Elevation change along length H (ft) = 60
 t_c (min) = 19.7

Flow Path 3
Hydraulic length of watershed L (ft) = 2,657
Peak Elevation of watershed (ft) = 330
Low Elevation of watershed (ft) = 245
Elevation change along length H (ft) = 85
 t_c (min) = 12.7

Cell 1

Flow Path 1
Hydraulic length of watershed L (ft) = 1,660
Peak Elevation of watershed (ft) = 322
Low Elevation of watershed (ft) = 270
Elevation change along length H (ft) = 52
 t_c (min) = 8.9

CONCLUSION

Most of the drainage area is within the Flow Path 1 and 3 areas.
Use a Time of Concentration of 10-Minutes

This page intentionally left blank.

HDR Computation

Project: Charah Colon Mine	Computed PAW	Date 11/03/14
Subject: Permit Application	Checked EAW	Date 11/6/14
Task: Drainage - Perimeter Channels	Sheet 1	of 3

Objective Design the stormwater channels around the perimeter of the structural fill for the 25-yr storm. Assume sideslope swales and/or sloop drains are installed as fill progresses. This will minimize the drainage area.

References

1. NC Erosion and Sediment Control Planning and Design Manual.
2. "Elements of Urban Stormwater Design" by H. Rooney Malcom, P.E.
3. NCDOT Standard Specifications for Roads and Structures
4. North American Green Product Brochure version 4.11
5. East Coast Erosion Blankets (ECS-1)
6. Maccaferri
7. Green Armor Systems
8. NOAA Atlas 14, Volume 2, Version 3 (Sanford, NC)

Equations

Normal Depth Procedure (Manning's Eqn)	Ref 2
$Z_{av} = AR^{2/3}$	Area (A) = $bd + z d^2$
$Z_{req} = Q n / 1.49s^{0.5}$	$R = \text{Area} / (b+2d(z^2+1)^{0.5})$
$AR^{2/3} = Q n / 1.49s^{0.5}$	Avg Shear Stress (T) = $d*s*\text{unit weight of water}$
Q (cfs) = CIA	$Z_{av} = Z_{req}$

Channel Design

Min Channel Freeboard =	0.2	ft	
Inside Channel Side Slope =	2	(enter X for X:1)	
Outside Channel Side Slope =	2	(enter X for X:1)	
Bottom Width, b =	4	ft	
Runoff Coeff (initial)=	0.60	Ag land, smooth	Ref 1
Runoff Coeff (permanent)=	0.25	Pasture, Sandy	Ref 1
I (in/hr) =	6.76	25-yr, 10-min Design Storm (Sanford, NC)	Ref 8

Various Lining Types

*Depth of Flow is not specified for Manning's' n

Lining Type	Lining Description	Manning's n		Vp (ft/sec)	Allowable Shear Stress (psf)
		depths of 0-0.5 ft	depths of 0.5-2.0 ft		
A	Jute Net (HEC-15)		0.015	2.0	0.45
B	Erosion Control Blanket Single Net (Curlex 1)		0.034	5.0	1.55
C	Erosion Control Blanket, Straw w/ Single Net (Ref 4)*		0.025	6.7	1.50
D	Erosion Control Blanket Double Net (Curlex HV)		0.026	10.0	1.65
E	Ordinary Firm Loam (Ref 2)	0.023	0.020	3.5	2.0
F	Grass Lined (Ref 1)*		0.030	5.0	2.0
G	6" Rip Rap (Ref 2, Ref 1)		0.069	9.0	2.0
H	GreenArmor 7010 (vegetated)		0.034	16.0	8.0
I	Unvegetated Turf Reinforcement Mat (TRM) (NAG C350)		0.025	9.5	2.25
J	Class D Phase 2 (Partially vegetated) TRM (NAG C350)		0.048	14.0	3.34
K	12" Rip Rap (Ref 2, Ref 1)		0.078	12.5	4.0
L	Class B Phase 3 (Fully vegetated) TRM (NAG C350)		0.048	18.0	5.7
M	Reno Mattress (6-inch, unvegetated) Ref 6		0.0277	13.8	4.3
N	Reno Mattress (6-inch, vegetated) Ref 6		0.050	13.8	8.35
O	Smart Ditch (Pre-formed HDPE channel)		0.022	-	-
P	Concrete (HEC-15, EPA 832-F-99-002)		0.013	25.0	10.0

HDR Computation

Project: Charah Colon Mine	Computed PAW	Date 11/03/14
Subject: Permit Application	Checked EAW	Date 11/6/14
Task: Drainage - Perimeter Channels	Sheet 2	of 3

Drainage Area is measured in plan view and does not account slope. Refer to sheet "Channels" for drainage areas.
 Select Lining System for each channel slope that will handle the design flow when vegetated and when initially placed

Node	Drainage Area (acres)	elev 2	elev 1	length (ft)	Channel Side Slope			Bottom Width, b (ft)
					Channel Slope	Inside (X:1)	Outside (X:1)	
DI #1	0.96	324	294	529	5.7%	2	2	4
DI #2	2.9	288	279	823	1.1%	2	2	4
DI #3W	5.2	280	269	1,100	1.0%	2	2	4
DI #3E	2.3	270	269	530	0.2%	2	2	4
DI #5W	3.2	280	259	643	3.3%	2	2	4
DI #5S	3.8	282	259	614	3.7%	2	2	4
DI #6 N	3.1	297	288	600	1.5%	2	2	4
DI #6 W a	8.2	322	296	1,034	2.5%	2	2	4
DI #6 W b	12.4	294	288	676	0.9%	2	2	4
Cell 1 N	5.3	290	284	558	1.1%	2	2	4
DI #7E	38.6	278	272	706	0.8%	2	2	4
DI #7W	4.1	276	271	434	1.2%	2	2	4

Channel Location	Flow Q (cfs)	Lining Type	Z _{req}	Flow Depth d (ft)	Cross Sectional Area (sf)	R	Z _{av}	Velocity (ft/sec)	Avg Shear Stress (lb/sf)	Comment
Initial Lining										
DI #1	3.9	E	0.22	0.17	0.75	0.16	0.22	5.2	0.6	Need Liner
DI #2	11.8	E	1.51	0.53	2.69	0.42	1.51	4.4	0.4	Need Liner
DI #3W	21.1	E	2.83	0.75	4.15	0.56	2.83	5.1	0.5	Need Liner
DI #3E	9.3	E	2.88	0.76	4.20	0.57	2.88	2.2	0.1	OK
DI #5W	13.0	E	0.96	0.41	1.98	0.34	0.96	6.6	0.8	Need Liner
DI #5S	15.4	E	1.07	0.44	2.13	0.36	1.07	7.3	1.0	Need Liner
DI #6 N	12.6	E	1.38	0.50	2.53	0.40	1.38	5.0	0.5	Need Liner
DI #6 W a	33.3	E	2.82	0.75	4.14	0.56	2.82	8.0	1.2	Need Liner
DI #6 W b	50.3	E	7.17	1.24	8.04	0.84	7.17	6.3	0.7	Need Liner
Cell 1 N	21.5	E	2.78	0.75	4.10	0.56	2.78	5.2	0.5	Need Liner
DI #7E	156.6	E	22.80	2.22	18.72	1.34	22.80	8.4	1.2	Need Liner
DI #7W	16.6	E	2.08	0.64	3.35	0.49	2.08	5.0	0.5	Need Liner
Temp Lining										
DI #1	3.9	C	0.27	0.20	0.86	0.18	0.27	4.5	0.7	OK
DI #2	11.8	C	1.89	0.60	3.14	0.47	1.89	3.8	0.4	OK
DI #3W	21.1	C	3.54	0.85	4.86	0.62	3.54	4.3	0.5	OK
DI #3E	9.3	C	3.60	0.86	4.92	0.63	3.60	1.9	0.1	OK
DI #5W	13.0	C	1.21	0.47	2.31	0.38	1.21	5.6	1.0	OK
DI #5S	15.4	C	1.34	0.50	2.48	0.40	1.34	6.2	1.2	OK
DI #6 N	12.6	C	1.72	0.57	2.94	0.45	1.72	4.3	0.5	OK
DI #6 W a	33.3	C	3.52	0.85	4.84	0.62	3.52	6.9	1.3	Need Diff Liner
DI #6 W b	50.3	C	8.96	1.38	9.37	0.92	8.86	5.4	0.8	OK
Cell 1 N	21.5	C	3.48	0.84	4.80	0.62	3.48	4.5	0.6	OK
DI #7E	156.6	C	28.49	2.47	22.07	1.47	28.49	7.1	1.3	Need Liner
DI #7W	16.6	C	2.60	0.72	3.91	0.54	2.60	4.3	0.5	OK

HDR Computation

Project: Charah Colon Mine	Computed PAW	Date 11/03/14
Subject: Permit Application	Checked EAW	Date 11/6/14
Task: Drainage - Perimeter Channels	Sheet 3	of 3

Channel Location	Flow Q (cfs)	Lining Type	Z _{req}	Flow Depth d (ft)	Cross Sectional Area (sf)	R	Z _{av}	Velocity (ft/sec)	Avg Shear Stress (lb/sf)	Comment
Permanent Lining										
DI #1	1.6	F	0.14	0.13	0.57	0.12	0.14	2.9	0.5	OK
DI #2	4.9	F	0.94	0.41	1.95	0.34	0.94	2.5	0.3	OK
DI #3W	8.8	F	1.77	0.58	3.00	0.45	1.77	2.9	0.4	OK
DI #3E	3.9	F	1.80	0.59	3.03	0.46	1.80	1.3	0.1	OK
DI #5W	5.4	F	0.60	0.31	1.44	0.27	0.60	3.7	0.6	OK
DI #5S	6.4	F	0.67	0.33	1.55	0.28	0.67	4.1	0.8	OK
DI #6 N	5.2	F	0.86	0.38	1.84	0.32	0.86	2.9	0.4	OK
DI #6 W a	13.9	F	1.76	0.58	2.98	0.45	1.76	4.6	0.9	OK
DI #6 W b	21.0	F	4.48	0.97	5.74	0.69	4.48	3.7	0.5	OK
Cell 1 N	9.0	F	1.74	0.57	2.96	0.45	1.74	3.0	0.4	OK
DI #7E	65.2	F	14.25	1.76	13.25	1.12	14.25	4.9	0.9	OK
DI #7W	6.9	F	1.30	0.49	2.43	0.39	1.30	2.9	0.4	OK

Select an appropriate temp liner for DI 6W a and DI #7E

Channel Location	Channel Slope	Lining Type	Z _{req}	Flow Depth d (ft)	Cross Sectional Area (sf)	R	Z _{av}	Velocity (ft/sec)	Avg Shear Stress (lb/sf)	Comment
DI #6 W a	2.5%	H	4.72	0.99	5.96	0.71	4.72	0.7	1.6	OK
DI #7E	0.8%	H	12.27	1.63	11.88	1.05	12.27	0.5	0.9	OK

CONCLUSION

Channel	Inside Channel (X:1)	Outside Channel (X:1)	Bottom Width, b (ft)	Slope (%)	Min Depth (ft)	Build Depth (ft)	Top Width (ft)	Temporary Lining	Permanent Lining
DI #1	2	2	4	5.7%	1.2	2	12	Straw w/ Single Net	Grass Lined
DI #2	2	2	4	1.1%	0.8	2	12	Straw w/ Single Net	Grass Lined
DI #3W	2	2	4	1.0%	1.1	2	12	Straw w/ Single Net	Grass Lined
DI #3E	2	2	4	0.2%	1.1	2	12	Straw w/ Single Net	Grass Lined
DI #5W	2	2	4	3.3%	0.7	2	12	Straw w/ Single Net	Grass Lined
DI #5S	2	2	4	3.7%	0.7	2	12	Straw w/ Single Net	Grass Lined
DI #6 N	2	2	4	1.5%	0.8	2	12	Straw w/ Single Net	Grass Lined
DI #6 W a	2	2	4	2.5%	1.2	2	12	GreenArmor 7010	Grass Lined
DI #6 W b	2	2	4	0.9%	1.6	2	12	Straw w/ Single Net	Grass Lined
Cell 1 N	2	2	4	1.1%	1.0	2	12	Straw w/ Single Net	Grass Lined
DI #7E	2	2	4	0.8%	2.7	3	16	GreenArmor 7010	Grass Lined
DI #7W	2	2	4	1.2%	0.9	2	12	Straw w/ Single Net	Grass Lined

Though Channel DI #6Wa & DI #7E requires a heavier temporary liner than the other channels, the permanent liner for all channels is grass. Therefore, using the Straw w/ Single Net could be used but additional maintenance of the channel may be necessary until grass is established.

This page intentionally left blank.

HDR Computation

Project:	Charah Colon Mine	Computed	PAW	Date	11/03/14
Subject:	Permit Application	Checked	EAW	Date	11/6/14
Task:	Drainage - Sideslope Swales	Sheet		1 of	2

Objective Design the sideslope channels on the structural fill for the 25-yr storm.

References

1. NC Erosion and Sediment Control Planning and Design Manual.
2. "Elements of Urban Stormwater Design" by H. Rooney Malcom, P.E.
3. NCDOT Standard Specifications for Roads and Structures
4. North American Green Product Brochure version 4.11
5. East Coast Erosion Blankets (ECS-1)
6. Maccaferri
7. Green Armor Systems
8. NOAA Atlas 14, Volume 2, Version 3 (Sanford, NC)

Equations

Normal Depth Procedure (Manning's Eqn) Ref 2

$$Z_{av} = AR^{2/3} \quad \text{Area (A)} = bd + z d^2$$

$$Z_{req} = Q n / 1.49s^{0.5} \quad R = \text{Area} / (b+2d(z^2+1)^{0.5})$$

$$AR^{2/3} = Q n / 1.49s^{0.5} \quad \text{Avg Shear Stress (T)} = d*s*\text{unit weight of water}$$

$$Q \text{ (cfs)} = CIA$$

$$Z_{av} = Z_{req}$$

Channel Design

- Min Channel Freeboard = 0.2 ft
- Inside Channel Side Slope = Varies (enter X for X:1)
- Outside Channel Side Slope = Varies (enter X for X:1)
- Bottom Width, b = Varies ft
- Runoff Coeff (initial)= 0.60 Ag land, smooth Ref 1
- Runoff Coeff (permanent)= 0.25 Pasture, Sandy Ref 1
- I (in/hr) = 6.76 25-yr, 10-min Design Storm (Sanford, NC) Ref 8

Various Lining Types

Lining Type	Lining Description	Manning's n		Vp (ft/sec)	Allowable Shear Stress (psf)
		depths of 0-0.5	depths of 0.5-		
A	Jute Net (HEC-15)		0.015	2.0	0.45
B	Erosion Control Blanket Single Net (Curlex 1)		0.034	5.0	1.55
C	Erosion Control Blanket, Straw w/ Single Net (Ref 4)*		0.025	6.7	1.50
D	Erosion Control Blanket Double Net (Curlex HV)		0.026	10.0	1.65
E	Ordinary Firm Loam (Ref 2)	0.023	0.020	3.5	2.0
F	Grass Lined (Ref 1)*		0.030	5.0	2.0
G	6" Rip Rap (Ref 2, Ref 1)		0.069	9.0	2.0
H	GreenArmor 7010 (unvegetated)		0.034	12.0	3.3
I	Unvegetated Turf Reinforcement Mat (TRM) (NAG C350)		0.025	9.5	2.25
J	Class D Phase 2 (Partially vegetated) TRM (NAG C350)		0.048	14.0	3.34
K	12" Rip Rap (Ref 2, Ref 1)		0.078	12.5	4.0
L	Class B Phase 3 (Fully vegetated) TRM (NAG C350)		0.048	18.0	5.7
M	Reno Mattress (6-inch, unvegetated) Ref 6		0.0277	13.8	4.3
N	Reno Mattress (6-inch, vegetated) Ref 6		0.050	13.8	8.35
O	Smart Ditch (Pre-formed HDPE channel)		0.022	-	-
P	Concrete (HEC-15, EPA 832-F-99-002)		0.013	25.0	10.0

*Depth of Flow is not specified for Manning's' n

HDR Computation

Project: Charah Colon Mine	Computed PAW	Date 11/03/14
Subject: Permit Application	Checked EAW	Date 11/6/14
Task: Drainage - Sideslope Swales	Sheet 2	of 2

Drainage Area is measured in plan view and does not account slope.

Select Lining System for each channel slope that will handle the design flow when vegetated and when initially placed

Channel Location	Drainage Area (acres)	Channel Side Slope			Bottom Width, b (ft)	
		Channel Slope	Inside (X:1)	Outside (X:1)		
Sideslope	13.3	2.0%	4	4	0	Largest Drainage Area (DI #5 on the Slope Drain Areas)
Diversion Berm	7.5	0.25%	2	2	0	Largest Drainage Area (DI #3)

Channel Location	Flow Q (cfs)	Lining Type	Z _{req}	Flow Depth d (ft)	Cross Sectional Area (sf)	R	Z _{av}	Velocity (ft/sec)	Avg Shear Stress	Comment
									(lb/sf)	
Initial Lining										
Sideslope	53.9	E	5.12	1.31	6.91	0.64	5.12	7.8	1.6	Need Liner
Diversion Berm	30.4	E	8.17	2.07	8.59	0.93	8.17	3.5	0.3	Need Liner
Temp Lining										
Sideslope	53.9	C	6.40	1.43	8.17	0.69	6.40	6.6	1.8	Needs Liner
Diversion Berm	30.4	C	10.21	2.25	10.16	1.01	10.21	3.0	0.4	OK

Channel Location	Flow Q (cfs)	Lining Type	Z _{req}	Flow Depth d (ft)	Cross Sectional Area (sf)	R	Z _{av}	Velocity (ft/sec)	Avg Shear Stress	Comment
									(lb/sf)	
Permanent Lining										
Sideslope	22.5	F	3.20	1.10	4.86	0.53	3.20	4.6	1.4	OK
Diversion Berm	12.7	F	5.10	1.74	6.04	0.78	5.10	2.1	0.3	OK

CONCLUSION

	Side Slope			Min to Construct		
	Inside Channel (X:1)	Outside Channel (X:1)	Bottom Width, b (ft)	Slope (%)	Depth (ft)	Top Width (ft)
	Sideslope	4	4	0	2.0%	1.1
Diversion Berm	2	2	0	0.25%	1.7	6.9

Though the Straw w/ Single Net temporary liner for the sideslope is greater than the allowable shear stress, since it a temporary condition and the permanent liner is grass, the Straw w/ Single Net will work but the channel will need to be monitored and maintained until vegetation is established.

Channels to have a temporary liner (Straw w/ Single Net)
Permanent liner is grass.

HDR Computation

Project: Charah Colon Mine	Computed PAW	Date 11/03/14
Subject: Permit Application	Checked: EAW	Date: 11/6/14
Task: Drainage - Slope Drains	Sheet: 1	of: 1

Objective: Size the slope drains for the 25-year storm.

Equations:

$$Q \text{ (cfs)} = CIA$$

Runoff Coeff (initial)= 0.60 Ag land, smooth

Runoff Coeff (permanent)= 0.25 Pasture, Sandy

I (in/hr) = 6.76 25-yr, 10-min Design Storm (Sanford, NC)

Drainage Area (acres) = **Use largest drainage area**

$$D_{REQD} = 16 \left[\frac{Qn}{\sqrt{s}} \right]^{\frac{3}{8}}$$

area to pipe is in "post" condition

Manning's

Theoretical Size for pipe flowing full

D = Pipe diameter (inches)

Q = Peak Flow (cfs)

0.012 = n, Manning's Roughness Coefficient for ADS CPP

s = Pipe Slope (ft fall / ft run)

Orifice $Q = C_d * A * (2gh)^{0.5}$

Q (cfs) = Discharge

0.60 = C_d Coefficient of Discharge (dimensionless)

A (sf) = Cross Sectional Area of Flow at the orifice entrance

32.2 = Acceleration of Gravity g (ft/sec²)

h (ft) = driving head measured from centroid of the orifice (pipe) to the water surface

"Driving Headwater Rqd for Total Flow" is the depth of water above the centerline of the pipe required to achieve the flow.

"Driving Head Available" is the depth of the channel from the center of the pipe to the top of the channel.

Allowable head 2.5 feet (depth of channel)

Scenario	Pipe Slope (ft fall / ft run)	Drainage Area (acres)	Theoretical Flow Q (cfs)	Theoretical Size for pipe (in)	Pipe Dia Selected (in)	Cross Sectional Area of orifice (sf)	Driving Headwater Rqd for Total Flow (ft)	Driving Head Available (ft)	Manning's Possible Discharge Q (cfs)	Comments
Sideslope	25%	13.3	22.5	12.7	18	1.8	7.0	1.8	57.0	This assumes entire area trying to get into the pipe though some is already in the pipe due to sideslope swales.
Sideslope	25%	7	11.8	10.0	18	1.8	1.9	1.8	57.0	This is drainage from only the sideslope swale.
Diversion Berm	1.0%	2	3.4	11.4	12	0.8	0.8	2.0	3.9	
Diversion Berm	1.0%	7.5	12.7	18.7	18	1.8	2.2	1.8	11.4	

Conclusion:

Use 18" corrugated plastic pipe (smooth wall)

This page intentionally left blank.

HDR Computation

| Job No. 453925-235691-018 |

Project:	Charah Colon Mine	Computed:	PAW	Date:	11/3/2014
Subject:	Permit Application	Checked:	EAW	Date:	11/6/2014
Task:	Drainage - Drop Inlets	Sheet:	1	of :	2

Objective: Size the drop inlet outlet pipe and grates for the 25-year storm.

References: 1. Elements of Urban Stormwater Design, H. Rooney Malcom, P.E.

Equations:

$Q = C_d * A (2 * g * h)^{0.5}$ Orifice Equation
 Q = cfs, discharge (based on permanent condition)
 $C_d = 0.59$ coefficient of discharge Ref 1, p III-11
 $g = 32.2$ ft/sec², gravity
 h = ft, driving head measured from the center of the pipe
 A = sf, cross sectional open area

	Open area (A)	Grate	Manufacturer
A	3.6	V-3610-7	East Jordan Iron Works
B	4.8	R-1792-KG	Neenah
C	6.0	R-3531-A	Neenah

Allowable head 2.0 feet (depth of channel)
 Max Flow from Slope Drains 22.5 cfs

Check for inlet control

Channel Location	Perimeter Channel		Slope Drain Flow (cfs)	Total Flow (cfs)	Grate	Open Area (sf)	Required head(ft)	
	Side 1	Side 2						
DI #1	1.6		22.5	24.1	C R-3531-A	6.0	0.7	Ok
DI #2	4.9		22.5	27.4	C R-3531-A	6.0	0.9	Ok
DI #3	8.8	3.9	22.5	35.2	C R-3531-A	6.0	1.5	Ok
DI #4	Minimal Flow							
DI #5	5.4	6.4	22.5	34.3	C R-3531-A	6.0	1.5	Ok
DI #6	5.2	21.0	22.5	48.7	C R-3531-A	6.0	2.9	Problem
DI #7	65.2	6.9	22.5	94.6	C R-3531-A	6.0	11.1	Problem

Cut the flow in half then determine the required grate inlet area

DI #6	24.3	0.59	C	R-3531-A	6.0	0.7	Ok
DI #7	47.3	0.59	C	R-3531-A	6.0	2.8	Problem
DI #7	65.2	0.59	2 large grates will be necessary		9.8	2.0	Ok

HDR Computation

| Job No. 453925-235691-018 |

Project:	Charah Colon Mine	Computed:	PAW	Date:	11/3/2014
Subject:	Permit Application	Checked:	EAW	Date:	11/6/2014
Task:	Drainage - Drop Inlets	Sheet:	2	of :	2

Size the Outlet culvert

$D=16*(Qn/s^{0.5})^{3/8}$ Theoretical Pipe Size (in) for pipe flowing full
 D = Pipe diameter (inches)
 Q = Peak Flow (cfs)
 n = 0.013 Manning's Roughness Coefficient for RCP
 s = Pipe Slope (ft fall / ft run)

Check pipe size based on Gravity Flow

	DI #1	DI #2	DI #3	DI #4	DI #5	DI #6	DI #7
Q (cfs) =	24.1	27.4	35.2	10.0	34.3	48.7	94.6
Number of pipes	1	1	1	1	1	1	2
Slope (%) =	1.0%	1.0%	1.0%	1.0%	1.0%	1.0%	1.0%
Theoretical Diameter (in) =	24.6	25.8	28.3	17.7	28.0	32.0	31.6
Culvert Diameter (in) =	30	30	30	18	30	36	36

Conclusion:

For DI #1, #2, #3, #4, and #5 use a grate with 6 sf open area and a 30" RCP Outlet
 For DI #6 use a two grates each with 6 sf open area and a 36" RCP Outlet
 For DI #7, use two grates with 12 sf open area and 2- 36" RCP Outlet

HDR Computation

| Job No. 453925-235691-018 |

Project:	Charah Colon Mine	Computed:	PAW	Date	11/03/14
Subject:	Permit Application	Checked	EAW	Date	11/6/14
Task:	Drainage - Drop Inlet across Power Line Right-of-Way	Sheet	1	of	2

Objective: Design the grate, drop inlet and culvert for the power line right-of-way crossing for the 25-year storm.

References: 1. Elements of Urban Stormwater Design, H. Rooney Malcom, P.E.

Equations:

- Q (cfs) = CIA
- Runoff Coeff (initial)= 0.60 Ag land, smooth
- Runoff Coeff (permanent)= 0.25 Pasture, Sandy
- I (in/hr) = 6.76 25-yr, 10-min Design Storm (Sanford, NC)
- A (acres) = 27.6
- Q initial (cfs) = 111.95
- Q permanent (cfs) = 46.64

Orifice Equation

$$Q = C_d * A (2 * g * h)^{0.5}$$

Q = cfs, discharge (based on permanent condition)
 C_d = coefficient of discharge 0.59
 g = 32.2 ft/sec², gravity
 h = ft, driving head measured from the center of the pipe
 A = sf, cross sectional open area

Ref 1, p III-11

Type	Open area (A)	Perimeter of grate	Grate	Manufacturer
A	3.6	10.4	V-3610-7	East Jordan Iron Works
B	4.8	12.1	R-1792-KG	Neenah
C	6.0	13	R-3531-A	Neenah

Weir Equation

$$Q = C_w * L * H^{1.5}$$

Q (cfs) = Discharge
 3.2 = C_w Weir Coefficient (dimensionless)
 varies = L (ft) Length of weir measured along crest
 H (ft) = driving head (crest of the weir to the water surface)

Allowable head 2.0 feet (depth of channel)

Check for inlet control

	Q (cfs)	C _d or C _w	Grate	Open Area (sf)	Required head(ft)		
Initial	111.95	0.59	C R-3531-A	6.0	15.5	Problem	Remove grate. Assume weir.
Initial	111.95	3.2	C R-3531-A	13.0	1.9	Ok	
Permanent	46.6	0.59	C R-3531-A	6.0	2.7	Problem	Divide the flow
Permanent	23.3	0.59	C R-3531-A	6.0	0.7	Ok	

HDR Computation

| Job No. 453925-235691-018 |

Project:	Charah Colon Mine	Computed:	PAW	Date	11/03/14
Subject:	Permit Application	Checked	EAW	Date	11/6/14
Task:	Drainage - Drop Inlet across Power Line Right-of-Way	Sheet	2	of	2

Size the Outlet culvert

$D=16*(Qn/s^{0.5})^{3/8}$ Theoretical Pipe Size (in) for pipe flowing full

D = Pipe diameter (inches)

Q = Peak Flow (cfs)

n = 0.013 Mannings Roughness Coefficient for RCP

s = Pipe Slope (ft fall / ft run)

DI Rim Elev	288
Depth of DI	3
DI bottom Elev	285
Culvert Invert In	285
Culvert Invert Out	282
Culvert Length	206
Slope	1.5%

Check pipe size based on Gravity Flow

	Initial Flow	Half of Initial Flow	Permanent Flow	Half of Permanent Flow
Q (cfs) =	111.95	55.97	46.6	23.32
Theoretical Diameter (in) =	40.7	31.4	29.3	22.6
Culvert Diameter (in) =	42	30	30	24

Conclusion:

Use a grate with a minimum inlet area of 6 sf .

Use 2 24" RCP culverts out of the drop inlets at 1.5% slope.

HDR Computation

Project:	Charah Colon Mine	Computed PAW	Date 11/03/14
Subject:	Permit Application	Checked: EAW	Date: 11/6/14
Task:	Drainage - Apron Outlets	Sheet	1 of: 1

Objective: Design the apron outlets for the drop inlets for the 25-year storm.

References:

- "Elements of Urban Stormwater Design" by H. Rooney Malcom, P.E.
- North Carolina Erosion and Sediment Control Planning and Design Manual

Equations:

Determine Tailwater conditions to size apron
 Use Normal Depth Procedure (Manning's Eqn.) Ref 1, II-7

$$Z_{av} = AR^{2/3} \qquad \text{Area (A)} = bd + z d^2$$

$$Z_{req} = Q n / 1.49s^{0.5} \qquad R = \text{Area} / (b+2d(z^2+1)^{0.5})$$

$$AR^{2/3} = Q n / 1.49s^{0.5} \qquad \text{Avg Shear Stress (T)} = d*s*\text{unit weight of water}$$

$$Z_{av} = Z_{req}$$

- n = 0.104 6-Inch Rip Rap Lined Channel (for depths of 0 to 0.5 ft) Ref 2
- n = 0.069 6-Inch Rip Rap Lined Channel (for depths of 0.5 to 2 ft) Ref 2
- Vp (ft/sec) = 9 Permissible Velocity for lining Ref 2
- Side Slope (z) = 6 enter X for X:1 (assumed)
- s (ft/ft) = 1.0% Outlet Slope (assumed)
- Diameter (in) = varies Drop Inlet Culvert
- Bottom Width (ft) = 10 Assumed

Flows (Q) based on the "Manning's Possible Discharge Q (cfs)" from the pipe calculation.
 For the Perm Rd North, the flow is doubles since there are 2 pipes.

0.5* Barrel Diameter (ft) = 1.25 Ref 2, 8.06.1

0.5* Barrel Diameter (ft) = 1.50

Minimum Tailwater Conditions: Flow Depth (d) < 0.5*Diameter of Culvert Ref 2 8.06a

Maximum Tailwater Conditions: Flow Depth (d) > 0.5*Diameter of Culvert Ref 2 8.06b

Diameter (in)	Q (cfs)	Z _{req}	Cross Sectional		R (ft)	Z _{av}	Velocity (ft/sec)	Tailwater
			Flow Depth, d (ft)	Area (sf)				
30	35.2	16.28	1.13	18.9	0.80	16.28	1.9	Min
36	48.7	22.54	1.33	23.9	0.91	22.54	2.0	Min

Size the aprons for each pipe using Ref 2:

The discharge on Figure 8.06a do not intersect the pipe size. Use the minimum length.

Conclusion:

Culvert Diameter (ft)	Entrance (ft)	Length (ft)	Outlet Width (ft)	Median Rip Rap Size (ft) d ₅₀	Selected Rip Rap Size (in)
2.5	7.5	16	19	0.5	Class B
3	9	20	23	0.5	Class B

This page intentionally left blank.

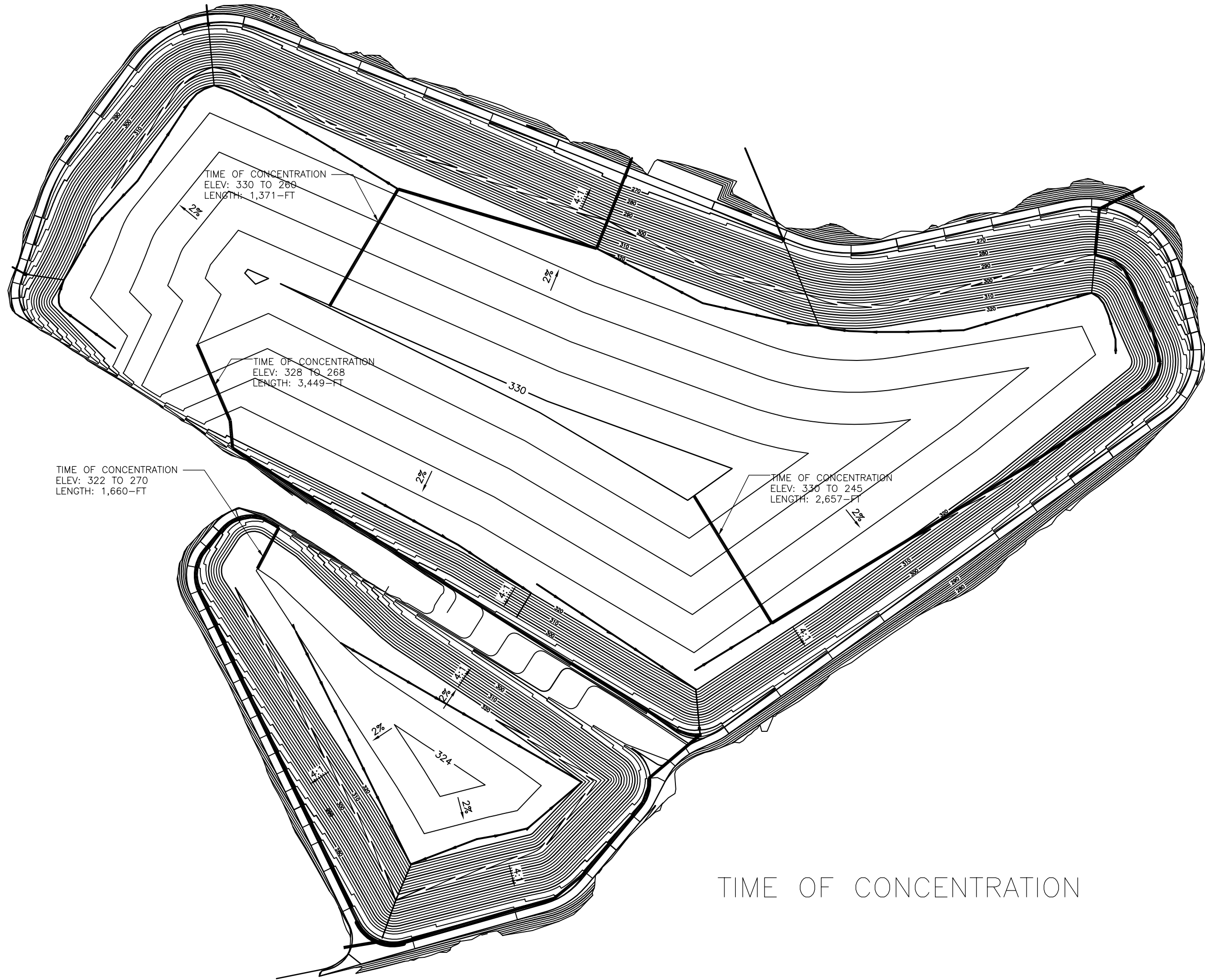

TIME OF CONCENTRATION

PERIMETER CHANNEL: DI #2
2.9 ACRES

PERIMETER CHANNEL:
5.2 ACRES

DI #3

PERIMETER CHANNEL:
3.2 ACRES

DI #5

PERIMETER CHANNEL:
2.3 ACRES

DI #4

DRAINAGE AREA:
13.3 ACRES

PERIMETER CHANNEL:
3.8 ACRES

DI #1

PERIMETER CHANNEL:
0.96 ACRES

PERIMETER CHANNEL:
8.2 ACRES

PERIMETER CHANNEL:
3.8 ACRES

PERIMETER CHANNEL:
3.1 ACRES

DI #6

DRAINAGE AREA UNDER POWER LINES:
2.7 ACRES

PERIMETER CHANNEL:
5.3 ACRES

PERIMETER CHANNEL:
4.1 ACRES

DI #7

PERIMETER CHANNEL:
3.0 ACRES

PERIMETER CHANNEL:
35.5 ACRES

PERIMETER CHANNEL AREAS

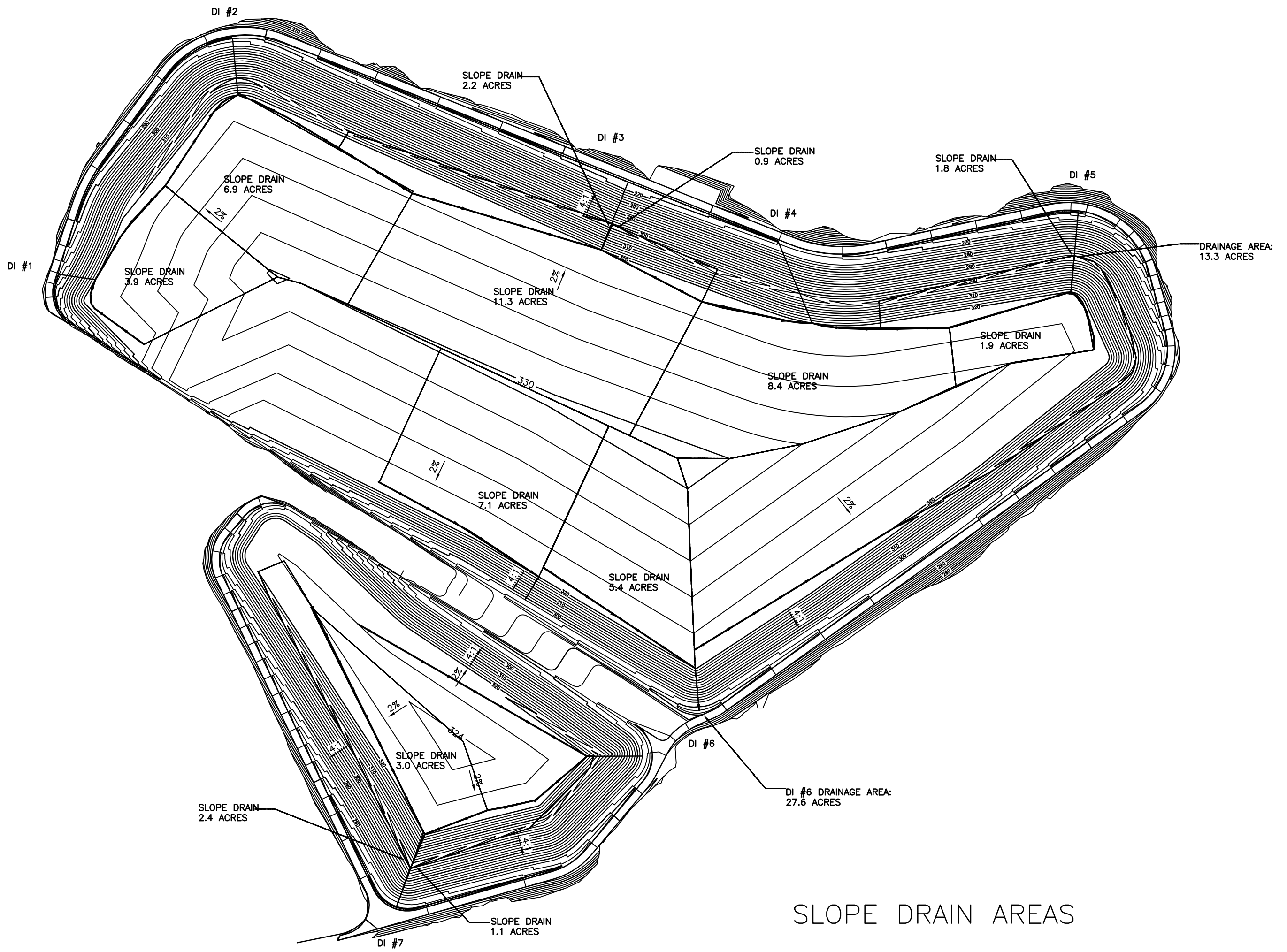

SLOPE DRAIN AREAS

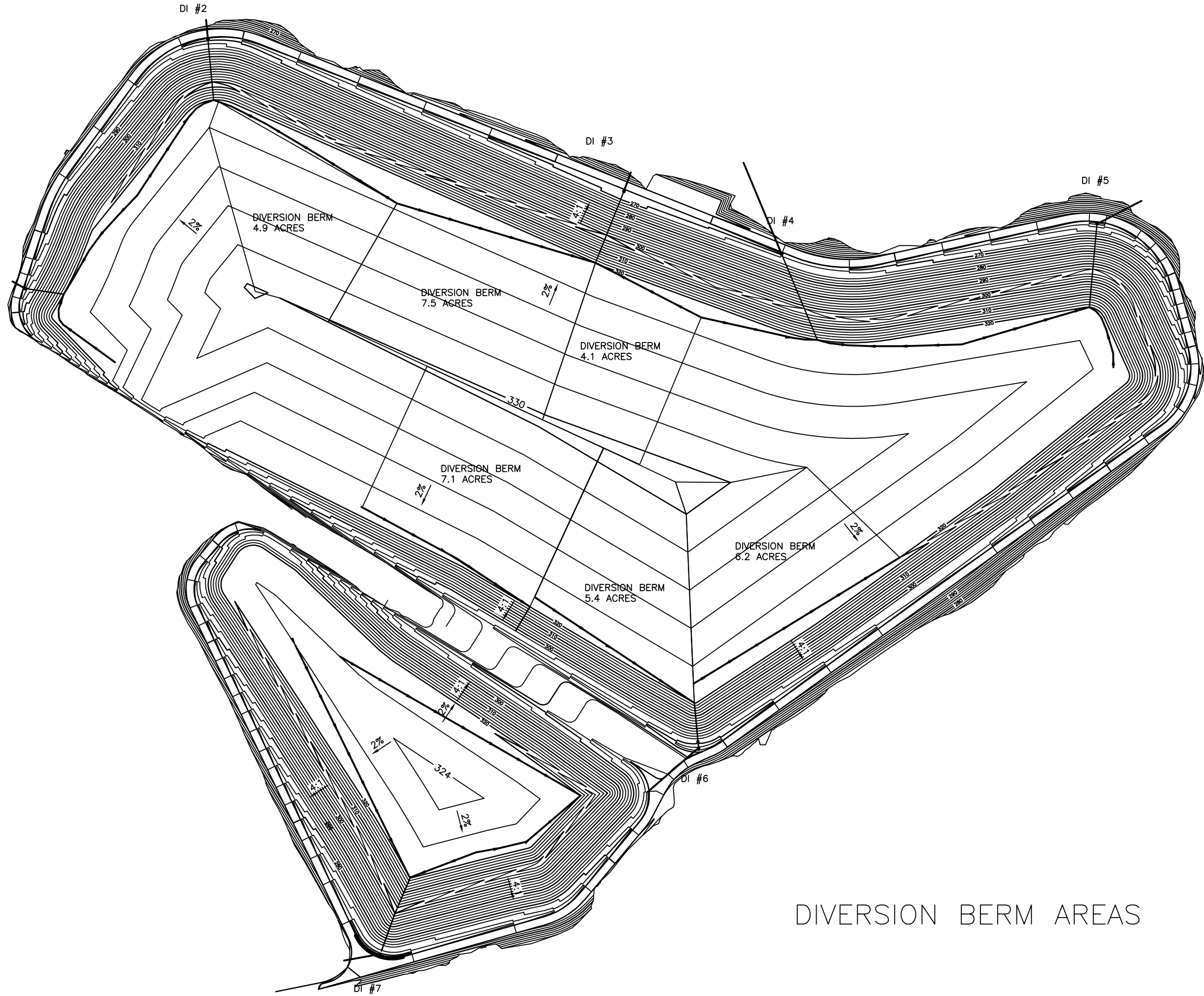

DIVERSION BERM AREAS



NOAA Atlas 14, Volume 2, Version 3
 Location name: Sanford, North Carolina, US*
 Latitude: 35.5361°, Longitude: -79.1459°
 Elevation: 297ft*
 * source: Google Maps



POINT PRECIPITATION FREQUENCY ESTIMATES

G.M. Bonnin, D. Martin, B. Lin, T. Parzybok, M.Yekta, and D. Riley

NOAA, National Weather Service, Silver Spring, Maryland

[PF tabular](#) | [PF graphical](#) | [Maps & aeriels](#)

PF tabular

PDS-based point precipitation frequency estimates with 90% confidence intervals (in inches/hour)¹										
Duration	Average recurrence interval (years)									
	1	2	5	10	25	50	100	200	500	1000
5-min	5.10 (4.66-5.62)	6.04 (5.51-6.64)	7.00 (6.38-7.70)	7.69 (7.00-8.45)	8.48 (7.68-9.31)	9.01 (8.14-9.89)	9.52 (8.53-10.4)	9.95 (8.88-10.9)	10.4 (9.23-11.4)	10.8 (9.48-11.8)
10-min	4.08 (3.72-4.48)	4.82 (4.40-5.31)	5.60 (5.11-6.17)	6.15 (5.60-6.76)	6.76 (6.12-7.42)	7.18 (6.48-7.87)	7.56 (6.78-8.28)	7.88 (7.03-8.64)	8.26 (7.30-9.05)	8.50 (7.46-9.33)
15-min	3.40 (3.10-3.74)	4.04 (3.69-4.45)	4.72 (4.31-5.20)	5.19 (4.72-5.70)	5.71 (5.17-6.27)	6.06 (5.47-6.64)	6.37 (5.72-6.98)	6.63 (5.92-7.27)	6.92 (6.13-7.59)	7.11 (6.24-7.81)
30-min	2.33 (2.13-2.56)	2.79 (2.55-3.07)	3.36 (3.06-3.69)	3.76 (3.42-4.13)	4.23 (3.83-4.64)	4.56 (4.12-5.00)	4.88 (4.38-5.34)	5.16 (4.61-5.66)	5.51 (4.87-6.04)	5.76 (5.06-6.32)
60-min	1.45 (1.33-1.60)	1.75 (1.60-1.93)	2.15 (1.96-2.37)	2.45 (2.23-2.69)	2.82 (2.55-3.09)	3.09 (2.79-3.39)	3.36 (3.01-3.68)	3.62 (3.23-3.97)	3.95 (3.50-4.33)	4.20 (3.69-4.61)
2-hr	0.856 (0.776-0.951)	1.04 (0.940-1.15)	1.29 (1.17-1.43)	1.48 (1.34-1.64)	1.73 (1.55-1.91)	1.92 (1.71-2.12)	2.10 (1.87-2.33)	2.29 (2.02-2.53)	2.53 (2.21-2.80)	2.72 (2.35-3.01)
3-hr	0.605 (0.550-0.672)	0.733 (0.666-0.814)	0.915 (0.831-1.02)	1.06 (0.957-1.17)	1.25 (1.12-1.38)	1.40 (1.25-1.54)	1.55 (1.37-1.71)	1.70 (1.50-1.88)	1.91 (1.66-2.11)	2.08 (1.79-2.30)
6-hr	0.363 (0.331-0.401)	0.439 (0.401-0.484)	0.549 (0.500-0.606)	0.636 (0.577-0.700)	0.753 (0.679-0.827)	0.846 (0.758-0.928)	0.942 (0.837-1.03)	1.04 (0.915-1.14)	1.18 (1.02-1.29)	1.29 (1.10-1.41)
12-hr	0.214 (0.195-0.236)	0.258 (0.236-0.286)	0.325 (0.296-0.359)	0.378 (0.342-0.417)	0.452 (0.406-0.496)	0.511 (0.456-0.560)	0.573 (0.506-0.627)	0.638 (0.558-0.698)	0.730 (0.627-0.799)	0.804 (0.681-0.880)
24-hr	0.125 (0.116-0.134)	0.151 (0.141-0.162)	0.190 (0.177-0.204)	0.220 (0.205-0.236)	0.262 (0.242-0.281)	0.295 (0.273-0.316)	0.328 (0.303-0.353)	0.364 (0.334-0.390)	0.412 (0.377-0.442)	0.449 (0.410-0.483)
2-day	0.073 (0.068-0.078)	0.088 (0.082-0.094)	0.109 (0.102-0.117)	0.126 (0.117-0.136)	0.150 (0.138-0.161)	0.168 (0.155-0.180)	0.187 (0.172-0.201)	0.206 (0.189-0.222)	0.233 (0.213-0.251)	0.254 (0.231-0.274)
3-day	0.051 (0.048-0.055)	0.062 (0.058-0.066)	0.077 (0.071-0.082)	0.088 (0.082-0.095)	0.104 (0.097-0.112)	0.117 (0.108-0.126)	0.130 (0.120-0.140)	0.144 (0.132-0.154)	0.162 (0.148-0.174)	0.177 (0.161-0.190)
4-day	0.041 (0.038-0.044)	0.049 (0.046-0.052)	0.060 (0.056-0.065)	0.069 (0.065-0.074)	0.082 (0.076-0.088)	0.092 (0.085-0.098)	0.102 (0.094-0.109)	0.112 (0.103-0.120)	0.127 (0.116-0.136)	0.138 (0.125-0.148)
7-day	0.027 (0.025-0.029)	0.032 (0.030-0.034)	0.039 (0.036-0.042)	0.044 (0.041-0.048)	0.052 (0.048-0.056)	0.058 (0.054-0.062)	0.064 (0.060-0.069)	0.071 (0.065-0.076)	0.080 (0.073-0.085)	0.087 (0.079-0.093)
10-day	0.021 (0.020-0.023)	0.025 (0.024-0.027)	0.031 (0.029-0.033)	0.035 (0.032-0.037)	0.040 (0.037-0.043)	0.044 (0.041-0.047)	0.049 (0.045-0.052)	0.053 (0.049-0.057)	0.059 (0.055-0.063)	0.064 (0.059-0.068)
20-day	0.014 (0.014-0.015)	0.017 (0.016-0.018)	0.020 (0.019-0.021)	0.022 (0.021-0.024)	0.026 (0.024-0.027)	0.028 (0.026-0.030)	0.031 (0.029-0.033)	0.034 (0.031-0.036)	0.037 (0.034-0.039)	0.040 (0.037-0.042)
30-day	0.012 (0.011-0.013)	0.014 (0.013-0.015)	0.016 (0.015-0.017)	0.018 (0.017-0.019)	0.020 (0.019-0.022)	0.022 (0.021-0.024)	0.024 (0.022-0.025)	0.026 (0.024-0.027)	0.028 (0.026-0.030)	0.030 (0.028-0.032)
45-day	0.010 (0.010-0.011)	0.012 (0.011-0.013)	0.014 (0.013-0.014)	0.015 (0.014-0.016)	0.017 (0.016-0.017)	0.018 (0.017-0.019)	0.019 (0.018-0.020)	0.020 (0.019-0.022)	0.022 (0.021-0.023)	0.023 (0.022-0.025)
60-day	0.009 (0.009-0.010)	0.011 (0.010-0.011)	0.012 (0.011-0.013)	0.013 (0.012-0.014)	0.014 (0.014-0.015)	0.015 (0.015-0.016)	0.016 (0.016-0.017)	0.017 (0.016-0.018)	0.019 (0.018-0.020)	0.020 (0.018-0.021)

¹ Precipitation frequency (PF) estimates in this table are based on frequency analysis of partial duration series (PDS). Numbers in parenthesis are PF estimates at lower and upper bounds of the 90% confidence interval. The probability that precipitation frequency estimates (for a given duration and average recurrence interval) will be greater than the upper bound (or less than the lower bound) is 5%. Estimates at upper bounds are not checked against probable maximum precipitation (PMP) estimates and may be higher than currently valid PMP values. Please refer to NOAA Atlas 14 document for more information.

[Back to Top](#)

PF graphical

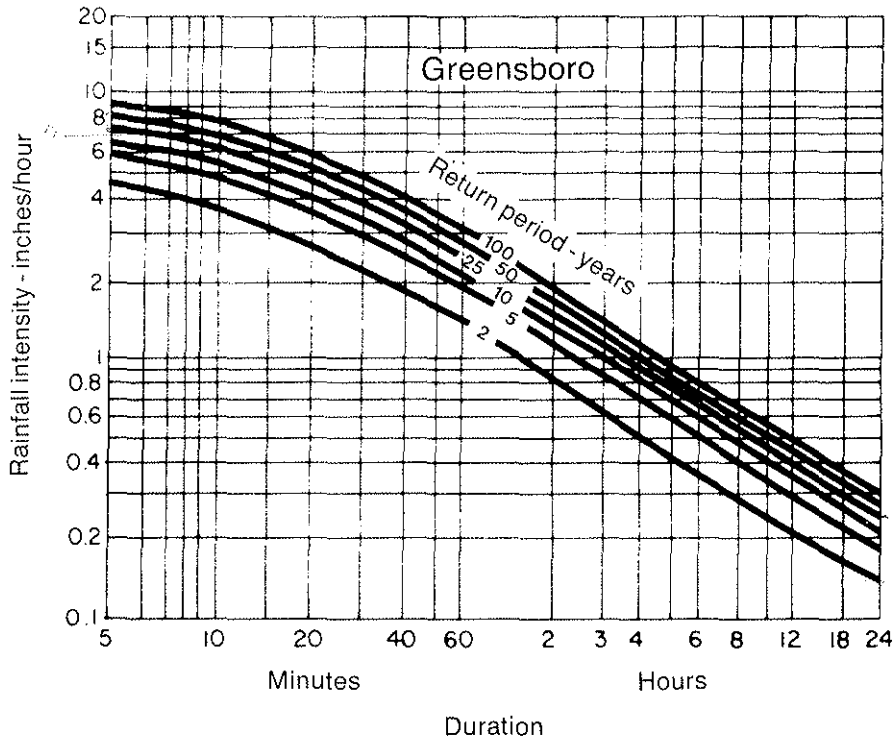

Figure 8.03d Rainfall intensity duration curves—Greensboro.

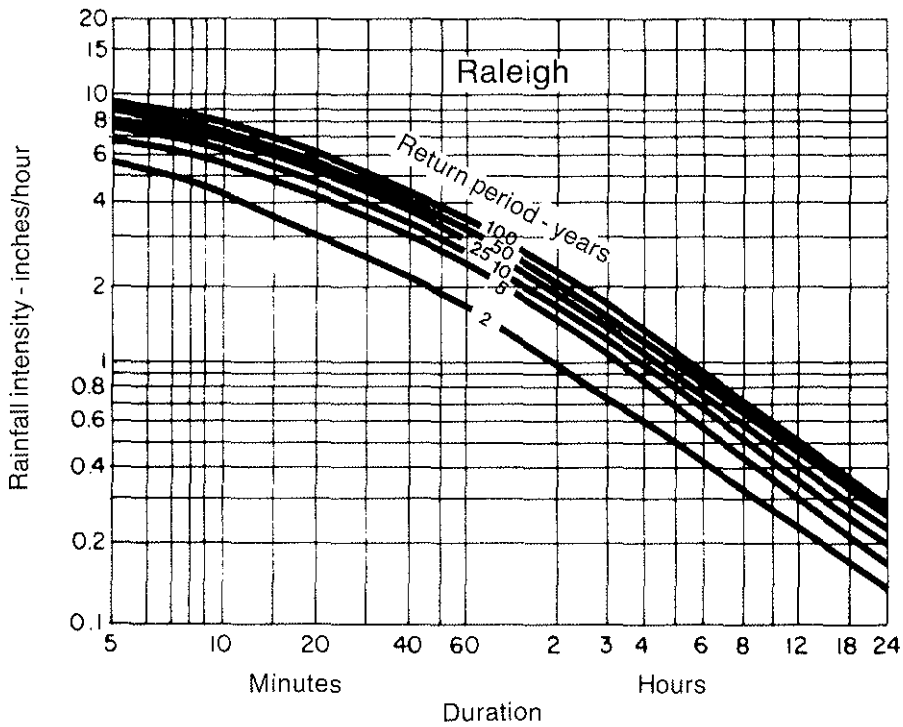

Figure 8.03e Rainfall intensity duration curves—Raleigh.

Table 8.03b
Value of Runoff Coefficient
(C) for Rational Formula

Land Use	C	Land Use	C
Business:		Lawns:	
Downtown areas	0.70-0.95	Sandy soil, flat, 2%	0.05-0.10
Neighborhood areas	0.50-0.70	Sandy soil, ave., 2-7%	0.10-0.15 0.15-0.20
Residential:		Sandy soil, steep, 7%	0.13-0.17 0.18-0.22
Single-family areas	0.30-0.50	Heavy soil, flat, 2%	0.25-0.35
Multi units, detached	0.40-0.60	Heavy soil, ave., 2-7%	
Multi units, Attached	0.60-0.75	Heavy soil, steep, 7%	0.30-0.60
Suburban	0.25-0.40		0.20-0.50
Industrial:		Agricultural land:	
Light areas	0.50-0.80	Bare packed soil	0.30-0.60
Heavy areas	0.60-0.90	Smooth	0.20-0.50
Parks, cemeteries	0.10-0.25	Rough	0.20-0.40
Playgrounds	0.20-0.35	Cultivated rows	0.10-0.25
Railroad yard areas	0.20-0.40	Heavy soil no crop	
Unimproved areas	0.10-0.30	Heavy soil with crop	0.15-0.45 0.05-0.25
Streets:		Sandy soil no crop	0.05-0.25
Asphalt	0.70-0.95	Sandy soil with crop	0.10-0.25
Concrete	0.80-0.95	Pasture	
Brick	0.70-0.85	Heavy soil	0.15-0.45
Drives and walks	0.75-0.85	Sandy soil	0.05-0.25
Roofs	0.75-0.85	Woodlands	0.05-0.25

NOTE: The designer must use judgement to select the appropriate C value within the range for the appropriate land use. Generally, larger areas with permeable soils, flat slopes, and dense vegetation should have lowest C values. Smaller areas with slowly permeable soils, steep slopes, and sparse vegetation should be assigned highest C values.

Source: American Society of Civil Engineers

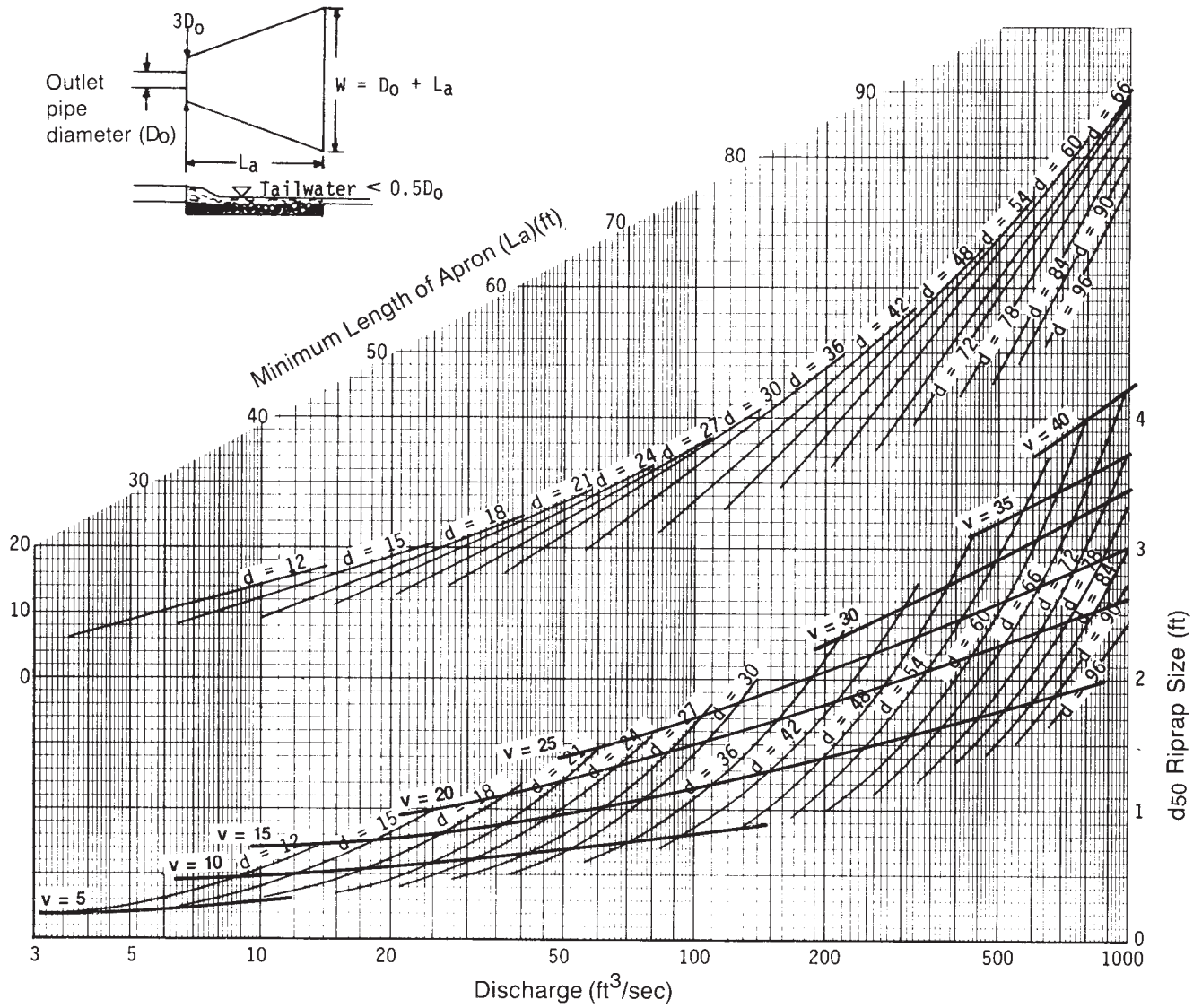

Curves may not be extrapolated.

Figure 8.06a Design of outlet protection protection from a round pipe flowing full, minimum tailwater condition ($T_w < 0.5$ diameter).

Project: Charah Colon Mine	Computed: EAW	Date: 1/4/15
Subject: Permit Application	Checked: PAW	Date: 1/4/15
Task: Sediment Basin #1	Sheet: 1	Of: 4

Objective Design the sediment basin to contain the 10-year storm and pass the 100-year storm without over topping the berm.

References

1. NC Erosion and Sediment Control Planning and Design Manual.
2. "Elements of Urban Stormwater Design" by H. Rooney Malcom, P.E.
3. VA Erosion and Sediment Control Handbook
3. NOAA Atlas 14, Volume 2, Version 3

Given

	Phase	1	2	2	2		
Storm Event (yrs) =		10	10	25	100		
Total Drainage Area A (ac) =		5.4	9.3	9.3	9.3		
Disturbed Area (ac) =		5.4	9.3	9.3	9.3		
Curve Number CN =		86	86	86	86	Hydrographs	
Rainfall Depth P (in) =		5.28	5.28	6.28	7.88	(24-hr rainfall)	Ref 3
Peak Flow Q _p (cfs) =		32.86	43.09	53.49	70.07	Hydrographs	

Design Criteria

Required sediment storage	1,800	cf / acre of drainage
Required sediment storage	16,740	cf (based on largest Phase)
Required Surface Area	435	sf/cfs of the 10-yr storm peak flow (based on the largest Phase in cfs)
Required Surface Area (SF)	18,744	of the 10-yr storm peak flow (based on the largest Phase)

Determine Shape of Basin:

Measure the area of the Basin using AutoCADD.

Calculate Volume of the Basin using Truncated Pyramid Method.

Shape factor used in hydrographs basin depth may be greater than indicated below

Elevation (ft)	Depth (ft)	Area (sf)	Volume (cf)	Cumulative Vol (cf)	Cumulative Vol (cy)
283	0	0	-	-	-
283	0	13,792	0	0	0
284	1	15,414	14,595	14,595	541
285	2	17,133	16,266	30,861	1,143
286	3	18,947	18,032	48,894	1,811
287	4	21,463	20,192	69,086	2,559
288	5	23,731	22,588	91,673	3,395
289	6	26,305	25,007	116,680	4,321

Design Sediment Depth (ft) = 3

Sediment Storage (cf) = 48,894

Required Sediment Storage Achieved

Design Surface Area Depth (ft) = 3

Surface Area (sf) = 18,947

Required Surface Area Achieved

Project: Charah Colon Mine	Computed: EAW	Date: 1/4/15
Subject: Permit Application	Checked: PAW	Date: 1/4/15
Task: Sediment Basin #1	Sheet: 2	Of: 4

Select Skimmer

A. R. Jarrett Method

$$D = [Q / (2,310 * (H^{0.5}))^{0.5}$$

D = Diameter of Orifice (inches)
 Q = Dewater Rate (cf/day)
 H = Head on orifice, varies based on skimmer size (ft)

Skimmer Sizes (Inches)	Head (ft)
1.5	0.125
2	0.167
2.5	0.167
3	0.250
4	0.333
5	0.333
6	0.417
8	0.500

Volume to Dewater (cf) =	48,894		
Number of Skimmers	1		
Days to Drain =	5	<i>assumed</i>	
Q each (cf/day) =	9,779		0.11 cfs
Selected Skimmer Size (inches) =	4		
Head on Skimmer (feet) =	0.333		
Diameter of Orifice (inches) =	2.7		

Route the flow through the Basin

Riser is not perforated, but skimmer is attached.

$$S = (1000/CN) - 10$$

$$\text{Runoff Depth } Q^* \text{ (inches)} = (P-0.2S)^2 / (P+0.8S)$$

$$T_p \text{ (min)} = 60.5(Q^*)A/Q_p / 1.39$$

Ref 2, III-4

	1	2	2	2
Storm Event (yrs) =	10	10	25	100
S =	1.63	1.63	1.63	1.63
Runoff Depth Q* (inches) =	3.73	3.73	4.68	6.22
Time to Peak T _p (min) =	26.67	35.03	35.39	35.90

Determine Pond Storage Elevation (Z_{water}):

Pick one point near max expected water surface and the other at the mid depth.

$$Z_1 \text{ (ft)} = 3 \quad S_1 \text{ (cf)} = 48,894$$

$$Z_2 \text{ (ft)} = 6 \quad S_2 \text{ (cf)} = 116,680$$

$$b = \ln(S_2/S_1) / \ln(Z_2/Z_1) = 1.3$$

$$K_S = S_2 / Z_2^b = 12,318$$

Ref 2, III-8

Project: Charah Colon Mine	Computed: EAW	Date: 1/4/15
Subject: Permit Application	Checked: PAW	Date: 1/4/15
Task: Sediment Basin #1	Sheet: 3	Of: 4

Determine Settling Velocity

Conversion Factor = 3.281 ft/sec per m/sec
 Gravitational Acceleration, g (m/s^2) = 9.81
 Specific Gravity of soil (s_s) = 2.6
 Kinematic Viscosity of water (ν) = 1.14E-06 m^2 / sec @ 20°C Ref 2, IV-11
 Diameter of the Design Particle d_{15} = 40.00E-06 m

Design Particle Settling Velocity = $(g / 18) * [(s_s - 1) / \nu] d^2 = 4.02E-03$ ft/sec

Route the Storm through the Basin using the Hydrograph Model

Set Height of Emergency Spillway at (ft) = 7.00 *See Hydrograph*
 Set Top of Dam at (ft) = 7.50

Emergency Spillway

Q_E (cfs) = 100-Yr Storm
 Q_E (cfs) = 5.8
 Cross Section = Trapezoid
 Channel Side Slope (z) = 5 (enter X for X:1)
 n = 0.03 Grass Lined
 V_p (ft/sec) = 5.0 Permissible Velocity for lining Ref 2, II-7
 Allowable Shear Stress (psf) = 2.0 Allowable Shear Stress for lining
 Bottom Width, b (ft) = 20

Calculate Required Depth of Spillway:

Normal-Depth Procedure

$AR^{2/3} = Qn / 1.49s^{0.5}$ $Q = VA$
 $Z_{req} = Qn / 1.49s^{0.5}$ Area (A) = $bd + z(d^2)$
 $Z_{av} = AR^{2/3}$ $R = Area / (b + 2d((z^2 + 1)^{.5}))$
 Avg Shear Stress (T) = $K_b * d * s$ * unit weight of water

Channel Slope ft/ft	Depth, d (ft)	A (sf)	Z_{req}	R	Z_{avail}	V (ft/sec)	T (psf)
0.01	0.18	3.77	1.17	0.17	1.17	1.5	0.1
0.02	0.15	3.03	0.82	0.14	0.82	1.9	0.2

Construct the channel to be : 20 ft, Bottom Width (measured at top of lining)
 0.5 ft, depth (measured at top of lining)
 1% slope

Anti-Seep Collar:

Anti-Seep Collar Size = 2 * Barrel Dia
 Anti-Seep Collar Size (ft) = 3
 Use Anti-Seep Collar Size (ft) = 3 x 3

Project: Charah Colon Mine	Computed: EAW	Date: 1/4/15
Subject: Permit Application	Checked: PAW	Date: 1/4/15
Task: Sediment Basin #1	Sheet: 4	Of: 4

Minimum Concrete Base for Riser:

Diameter of Riser (in) = 54 From Hydrograph
 Avg Density of Concrete (lbs/cf) = 87.6
 Density of Water (lbs/cf) = 62.4
 Riser Displacement (cf) = 101.79 $\text{Pi} * (\text{D}_R/24)^2 * \text{Total Ht of Riser}$
 Convert cf to cy = 27^{-1}
 Min Concrete Needed (cy) = 2.69
 Width & Length (ft) = 5.5
 Thickness (ft) = 2.4

Anti-Vortex Device:

Diameter of Riser (in) = 54 From Hydrograph
 Cylinder Diameter (in) = 78 Ref 3, III-104, Table 3.14-D
 Cylinder Thickness (gage) = 16
 Cylinder Height (in) = 25

Determine Tailwater conditions to size outlet apron

Use Normal Depth Procedure (Manning's Eqn.) Ref 2, II-7

$A * R^{2/3} = Q * n / 1.49 s^{0.5}$ Area (A) = $bd + z(d^2)$ $Z_{av} = A * R^{2/3}$
 $Z_{req} = Q * n / 1.49 s^{0.5}$ $R = \text{Area} / (b + 2d((z^2 + 1)^{0.5}))$

n = 0.069 6-inch diameter Rip Rap, Lined Channel
 Vp (ft/sec) = 9 Permissible Velocity for lining
 Side Slope (z) = 5 enter X for X:1
 s (ft/ft) = 0.02 Outlet Slope (estimated)
 Bottom Width (ft) = 9 6 * Barrel Diameter
 Q_B (cfs) = 10.0 Peak Flow out of the barrel 25-yr Hydrograph

Q (cfs)	Z _{req}	Flow Depth d (ft)	A (sf)	R (ft)	Z _{av}	V (ft/sec)
10.0	3.26	0.51	5.9	0.41	3.26	1.7

Flow Depth = Tailwater, d (ft) = 0.51 0.5* Barrel Diameter (ft) = 0.75 Ref 1, 8.06.3

Minimum Tailwater Conditions: $d < 0.5 * \text{Diameter of Outlet Pipe}$

Maximum Tailwater Conditions: $d > 0.5 * \text{Diameter of Outlet Pipe}$

Since the Tailwater is less than half of the diameter of the outlet, use Minimum Tailwater conditions.

Barrel Diameter (ft)	Entrance (ft)	Length (ft)	Outlet Width (ft)	Median Rip Rap Size d ₅₀	Selected Rip Rap Size (in)
1.5	4.5	10	12	0.3	Class A

Conclusion

The basin can contain the 10-yr storm and pass the 100-yr storm without overtopping the berm.

HDR Computation

Project:	Charah Colon Mine	Computed: PAW	Date: 12/31/14
Subject:	Permit Application	Checked: EAW	Date: 1/2/15
Task:	Riser Pipe Perforations/Skimmer Flow	Sheet 1	Of 2

Diameter of Riser (in) = 54
 Circumference of Riser (in) = 169.6
 Height of Riser from bottom of barrel (in) = 77 From Hydrograph
 Vertical spacing between holes (in) = 0 center to center
 Water Stage increment (ft) 0.05

Orifice Equation

$Q = C_d * A * (2 * g * h)^{0.5}$ Ref 1, p III-11
 Q = cfs, discharge
 $C_d = 0.6$ coefficient of discharge
 A = sf, cross sectional area
 $g = 32.2$ ft/sec², gravity
 h = ft, driving head measured from the center of the pipe

Row	Perforations					Skimmer	# of skimmers
	1	2	3	4	5	1	
Holes per row	0	0	0	0	0		
Hole Diameter (in)	0.75	0.75	0.75	0.75	0.75		
Spacing edge to edge (in)	#DIV/0!	#DIV/0!	#DIV/0!	#DIV/0!	#DIV/0!		
Inlet Area (sf)	0.000	0.000	0.000	0.000	0.000		
Hole Stage (in)	0.50	0.50	0.50	0.50	0.50		
Hole Stage (ft)	0.04	0.04	0.04	0.04	0.04		

Water Stage (ft)	Flow (cfs)	Flow (cfs)	Flow (cfs)	Flow (cfs)	Flow (cfs)	Flow (cfs)	Total Flow (cfs)
0.00	0.00	0.00	0.00			0.00	0.00
0.04	0.00	0.00	0.00			0.00	0.00
0.09	0.00	0.00	0.00			0.00	0.00
0.14	0.00	0.00	0.00			0.00	0.00
0.19	0.00	0.00	0.00			0.00	0.00
0.24	0.00	0.00	0.00			0.00	0.00
0.29	0.00	0.00	0.00			0.00	0.00
0.34	0.00	0.00	0.00			0.11	0.11
0.39	0.00	0.00	0.00			0.11	0.11
0.44	0.00	0.00	0.00			0.11	0.11
0.49	0.00	0.00	0.00			0.11	0.11
0.54	0.00	0.00	0.00			0.11	0.11
0.59	0.00	0.00	0.00			0.11	0.11
0.64	0.00	0.00	0.00			0.11	0.11
0.69	0.00	0.00	0.00			0.11	0.11
0.74	0.00	0.00	0.00			0.11	0.11
0.79	0.00	0.00	0.00			0.11	0.11
0.84	0.00	0.00	0.00			0.11	0.11
0.89	0.00	0.00	0.00			0.11	0.11
0.94	0.00	0.00	0.00			0.11	0.11
0.99	0.00	0.00	0.00			0.11	0.11
1.04	0.00	0.00	0.00			0.11	0.11
1.09	0.00	0.00	0.00			0.11	0.11
1.14	0.00	0.00	0.00			0.11	0.11
1.19	0.00	0.00	0.00			0.11	0.11
1.24	0.00	0.00	0.00			0.11	0.11
1.29	0.00	0.00	0.00			0.11	0.11
1.34	0.00	0.00	0.00			0.11	0.11
1.39	0.00	0.00	0.00			0.11	0.11
1.44	0.00	0.00	0.00			0.11	0.11
1.49	0.00	0.00	0.00			0.11	0.11
1.54	0.00	0.00	0.00			0.11	0.11
1.59	0.00	0.00	0.00			0.11	0.11

HDR Computation

Project:	Charah Colon Mine	Computed: PAW	Date: 12/31/14
Subject:	Permit Application	Checked: EAW	Date: 1/2/15
Task:	Riser Pipe Perforations/Skimmer Flow	Sheet 2	Of 2

1.64	0.00	0.00	0.00	0.11	0.11
1.69	0.00	0.00	0.00	0.11	0.11
1.74	0.00	0.00	0.00	0.11	0.11
1.79	0.00	0.00	0.00	0.11	0.11
1.84	0.00	0.00	0.00	0.11	0.11
1.89	0.00	0.00	0.00	0.11	0.11
1.94	0.00	0.00	0.00	0.11	0.11
1.99	0.00	0.00	0.00	0.11	0.11
2.04	0.00	0.00	0.00	0.11	0.11
2.09	0.00	0.00	0.00	0.11	0.11
2.14	0.00	0.00	0.00	0.11	0.11
2.19	0.00	0.00	0.00	0.11	0.11
2.24	0.00	0.00	0.00	0.11	0.11
2.29	0.00	0.00	0.00	0.11	0.11
2.34	0.00	0.00	0.00	0.11	0.11
2.39	0.00	0.00	0.00	0.11	0.11
2.44	0.00	0.00	0.00	0.11	0.11
2.49	0.00	0.00	0.00	0.11	0.11
2.54	0.00	0.00	0.00	0.11	0.11
2.59	0.00	0.00	0.00	0.11	0.11
2.64	0.00	0.00	0.00	0.11	0.11
2.69	0.00	0.00	0.00	0.11	0.11
2.74	0.00	0.00	0.00	0.11	0.11
2.79	0.00	0.00	0.00	0.11	0.11
2.84	0.00	0.00	0.00	0.11	0.11
2.89	0.00	0.00	0.00	0.11	0.11
2.94	0.00	0.00	0.00	0.11	0.11
2.99	0.00	0.00	0.00	0.11	0.11
3.04	0.00	0.00	0.00	0.11	0.11
3.09	0.00	0.00	0.00	0.11	0.11
3.14	0.00	0.00	0.00	0.11	0.11
3.19	0.00	0.00	0.00	0.11	0.11
3.24	0.00	0.00	0.00	0.11	0.11
3.29	0.00	0.00	0.00	0.11	0.11
3.34	0.00	0.00	0.00	0.11	0.11
3.39	0.00	0.00	0.00	0.11	0.11
3.44	0.00	0.00	0.00	0.11	0.11
3.49	0.00	0.00	0.00	0.11	0.11
3.54	0.00	0.00	0.00	0.11	0.11
3.59	0.00	0.00	0.00	0.11	0.11
3.64	0.00	0.00	0.00	0.11	0.11
3.69	0.00	0.00	0.00	0.11	0.11
3.74	0.00	0.00	0.00	0.11	0.11
3.79	0.00	0.00	0.00	0.11	0.11
3.84	0.00	0.00	0.00	0.11	0.11
3.89	0.00	0.00	0.00	0.11	0.11
3.94	0.00	0.00	0.00	0.11	0.11
3.99	0.00	0.00	0.00	0.11	0.11

Qp = 32.86 cfs
 Tp = 26.67 minutes
 dT = Max of 2 minutes
 or 1.0% of increment to peak

Sediment Basin # 1 Colon

Phase 1
 10 - year Storm Event

Number of Riser/Barrel Assemblies = 1
 Diameter of Barrel = 18 (in)
 Height of Riser above barrel = 4.9 (ft)
 Height of Riser from bottom of barrel = 6.4 (ft) elevation 289.40
 Emergency Spillway = 7.0 (ft) elevation 290.00
 Total Height of Dam = 7.5 (ft) elevation 290.50
 Length of Emergency Spillway = 20 (ft)
 Diameter of Riser = 54 (in)
 Permanent Pond Stage = 0 (ft) elevation 283.0

b = 1.3
 K_s = 12,318

4.0E-03 Settling Velocity of design particle (fps)
 2 Effective number of cells (2 is construction site #)
 100% Minimum Settling Efficiency
 4.1 ft Maximum Stage 287.10 msl elevation
 0.1 cfs Peak outflow
 0.1 cfs Peak Riser/Barrel outflow
 0.0 cfs Peak Weir flow

Notes:

1. Length of emergency spillway is the bottom width of the emergency spillway.
2. Settling efficiency neglects permanent pond volume

TIME (min)	INFLOW [cfs]	STORAGE [cu ft]	STAGE [ft]	Skimmer Flow [cfs]	RISER CAPACIT Y [cfs]	WEIR FLOW [cfs]	BARREL CAPACITY [cfs]	TOTAL OUTFLOW [cfs]	Bound Discharge [cfs]	Estimate d Surface Area (sf)	Settling Efficiency [%]
0	0.0	0	0.0	0.00	0.00	0.00	0.00	0.00	0.00	-	N/A
2	0.5	0	0.0	0.00	0.00	0.00	0.00	0.00	0.00	-	N/A
4	1.8	54	0.0	0.00	0.00	0.00	0.00	0.00	11.31	5,140	N/A
6	3.9	269	0.0	0.00	0.00	0.00	0.00	0.00	15.64	7,111	N/A
8	6.8	741	0.1	0.00	0.00	0.00	0.00	0.00	19.22	8,735	N/A
10	10.1	1,554	0.2	0.00	0.00	0.00	0.00	0.00	22.33	10,151	N/A
12	13.9	2,770	0.3	0.00	0.00	0.00	0.00	0.00	25.12	11,416	N/A
14	17.7	4,433	0.4	0.11	0.11	0.00	0.11	0.11	27.63	12,560	100%
16	21.5	6,545	0.6	0.11	0.11	0.00	0.11	0.11	29.91	13,594	100%
18	25.0	9,111	0.8	0.11	0.11	0.00	0.11	0.11	31.99	14,539	100%
20	28.0	12,099	1.0	0.11	0.11	0.00	0.11	0.11	33.88	15,401	100%
22	30.4	15,450	1.2	0.11	0.11	0.00	0.11	0.11	35.61	16,185	100%
24	32.1	19,088	1.4	0.11	0.11	0.00	0.11	0.11	37.17	16,895	100%
26	32.8	22,921	1.6	0.11	0.11	0.00	0.11	0.11	38.58	17,535	100%
28	32.7	26,844	1.9	0.11	0.11	0.00	0.11	0.11	39.83	18,107	100%
30	31.6	30,750	2.1	0.11	0.11	0.00	0.11	0.11	40.95	18,613	100%
32	29.7	34,530	2.3	0.11	0.11	0.00	0.11	0.11	41.92	19,056	100%
34	27.2	38,084	2.5	0.11	0.11	0.00	0.11	0.11	42.77	19,439	100%
36	24.7	41,334	2.6	0.11	0.11	0.00	0.11	0.11	43.48	19,765	100%
38	22.4	44,281	2.8	0.11	0.11	0.00	0.11	0.11	44.10	20,044	100%
40	20.3	46,953	2.9	0.11	0.11	0.00	0.11	0.11	44.62	20,284	100%
42	18.4	49,375	3.0	0.11	0.11	0.00	0.11	0.11	45.08	20,492	100%
44	16.7	51,571	3.1	0.11	0.11	0.00	0.11	0.11	45.48	20,674	100%
46	15.2	53,562	3.2	0.11	0.11	0.00	0.11	0.11	45.83	20,834	100%
48	13.7	55,367	3.3	0.11	0.11	0.00	0.11	0.11	46.14	20,974	100%
50	12.5	57,003	3.4	0.11	0.11	0.00	0.11	0.11	46.42	21,099	100%
52	11.3	58,485	3.5	0.11	0.11	0.00	0.11	0.11	46.66	21,209	100%
54	10.3	59,829	3.5	0.11	0.11	0.00	0.11	0.11	46.88	21,307	100%
56	9.3	61,047	3.6	0.11	0.11	0.00	0.11	0.11	47.07	21,394	100%
58	8.4	62,150	3.6	0.11	0.11	0.00	0.11	0.11	47.24	21,472	100%
60	7.7	63,149	3.7	0.11	0.11	0.00	0.11	0.11	47.39	21,542	100%
62	6.9	64,055	3.7	0.11	0.11	0.00	0.11	0.11	47.53	21,604	100%
64	6.3	64,875	3.8	0.11	0.11	0.00	0.11	0.11	47.65	21,660	100%
66	5.7	65,618	3.8	0.11	0.11	0.00	0.11	0.11	47.76	21,710	100%
68	5.2	66,290	3.8	0.11	0.11	0.00	0.11	0.11	47.86	21,755	100%
70	4.7	66,899	3.9	0.11	0.11	0.00	0.11	0.11	47.95	21,796	100%
72	4.3	67,450	3.9	0.11	0.11	0.00	0.11	0.11	48.03	21,832	100%
74	3.9	67,948	3.9	0.11	0.11	0.00	0.11	0.11	48.10	21,865	100%
76	3.5	68,399	3.9	0.11	0.11	0.00	0.11	0.11	48.17	21,894	100%
78	3.2	68,807	3.9	0.11	0.11	0.00	0.11	0.11	48.23	21,921	100%
80	2.9	69,176	4.0	0.11	0.11	0.00	0.11	0.11	48.28	21,944	100%
82	2.6	69,509	4.0	0.11	0.11	0.00	0.11	0.11	48.32	21,966	100%

84	2.4	69,810	4.0	0.11	0.11	0.00	0.11	0.11	48.37	21,985	100%
86	2.2	70,081	4.0	0.11	0.11	0.00	0.11	0.11	48.41	22,002	100%
88	2.0	70,327	4.0	0.11	0.11	0.00	0.11	0.11	48.44	22,018	100%
90	1.8	70,548	4.0	0.11	0.11	0.00	0.11	0.11	48.47	22,032	100%
92	1.6	70,747	4.0	0.11	0.11	0.00	0.11	0.11	48.50	22,045	100%
94	1.5	70,927	4.0	0.11	0.11	0.00	0.11	0.11	48.52	22,056	100%
96	1.3	71,088	4.0	0.11	0.11	0.00	0.11	0.11	48.55	22,066	100%
98	1.2	71,234	4.0	0.11	0.11	0.00	0.11	0.11	48.57	22,075	100%
100	1.1	71,364	4.1	0.11	0.11	0.00	0.11	0.11	48.58	22,084	100%
102	1.0	71,482	4.1	0.11	0.11	0.00	0.11	0.11	48.60	22,091	100%
104	0.9	71,587	4.1	0.11	0.11	0.00	0.11	0.11	48.61	22,098	100%
106	0.8	71,681	4.1	0.11	0.11	0.00	0.11	0.11	48.63	22,104	100%
108	0.7	71,765	4.1	0.11	0.11	0.00	0.11	0.11	48.64	22,109	100%
110	0.7	71,840	4.1	0.11	0.11	0.00	0.11	0.11	48.65	22,113	100%
112	0.6	71,907	4.1	0.11	0.11	0.00	0.11	0.11	48.66	22,118	100%
114	0.6	71,966	4.1	0.11	0.11	0.00	0.11	0.11	48.67	22,121	100%
116	0.5	72,019	4.1	0.11	0.11	0.00	0.11	0.11	48.67	22,125	100%
118	0.5	72,065	4.1	0.11	0.11	0.00	0.11	0.11	48.68	22,128	100%
120	0.4	72,106	4.1	0.11	0.11	0.00	0.11	0.11	48.69	22,130	100%
122	0.4	72,142	4.1	0.11	0.11	0.00	0.11	0.11	48.69	22,132	100%
124	0.3	72,173	4.1	0.11	0.11	0.00	0.11	0.11	48.70	22,134	100%
126	0.3	72,200	4.1	0.11	0.11	0.00	0.11	0.11	48.70	22,136	100%
128	0.3	72,223	4.1	0.11	0.11	0.00	0.11	0.11	48.70	22,137	100%
130	0.3	72,243	4.1	0.11	0.11	0.00	0.11	0.11	48.70	22,139	100%
132	0.2	72,260	4.1	0.11	0.11	0.00	0.11	0.11	48.71	22,140	100%
134	0.2	72,274	4.1	0.11	0.11	0.00	0.11	0.11	48.71	22,141	100%
136	0.2	72,285	4.1	0.11	0.11	0.00	0.11	0.11	48.71	22,141	100%
138	0.2	72,294	4.1	0.11	0.11	0.00	0.11	0.11	48.71	22,142	100%
140	0.2	72,301	4.1	0.11	0.11	0.00	0.11	0.11	48.71	22,142	100%
142	0.1	72,306	4.1	0.11	0.11	0.00	0.11	0.11	48.71	22,143	100%
144	0.1	72,309	4.1	0.11	0.11	0.00	0.11	0.11	48.71	22,143	100%
146	0.1	72,311	4.1	0.11	0.11	0.00	0.11	0.11	48.71	22,143	100%
148	0.1	72,311	4.1	0.11	0.11	0.00	0.11	0.11	48.71	22,143	100%
150	0.1	72,310	4.1	0.11	0.11	0.00	0.11	0.11	48.71	22,143	100%
152	0.1	72,308	4.1	0.11	0.11	0.00	0.11	0.11	48.71	22,143	100%
154	0.1	72,305	4.1	0.11	0.11	0.00	0.11	0.11	48.71	22,142	100%
156	0.1	72,301	4.1	0.11	0.11	0.00	0.11	0.11	48.71	22,142	100%
158	0.1	72,296	4.1	0.11	0.11	0.00	0.11	0.11	48.71	22,142	100%
160	0.1	72,290	4.1	0.11	0.11	0.00	0.11	0.11	48.71	22,142	100%
162	0.1	72,283	4.1	0.11	0.11	0.00	0.11	0.11	48.71	22,141	100%
164	0.0	72,276	4.1	0.11	0.11	0.00	0.11	0.11	48.71	22,141	100%
166	0.0	72,268	4.1	0.11	0.11	0.00	0.11	0.11	48.71	22,140	100%
168	0.0	72,260	4.1	0.11	0.11	0.00	0.11	0.11	48.71	22,140	100%
170	0.0	72,251	4.1	0.11	0.11	0.00	0.11	0.11	48.71	22,139	100%
172	0.0	72,242	4.1	0.11	0.11	0.00	0.11	0.11	48.70	22,139	100%
174	0.0	72,232	4.1	0.11	0.11	0.00	0.11	0.11	48.70	22,138	100%
176	0.0	72,222	4.1	0.11	0.11	0.00	0.11	0.11	48.70	22,137	100%
178	0.0	72,212	4.1	0.11	0.11	0.00	0.11	0.11	48.70	22,137	100%
180	0.0	72,201	4.1	0.11	0.11	0.00	0.11	0.11	48.70	22,136	100%
182	0.0	72,190	4.1	0.11	0.11	0.00	0.11	0.11	48.70	22,135	100%
184	0.0	72,179	4.1	0.11	0.11	0.00	0.11	0.11	48.70	22,135	100%
186	0.0	72,168	4.1	0.11	0.11	0.00	0.11	0.11	48.69	22,134	100%
188	0.0	72,156	4.1	0.11	0.11	0.00	0.11	0.11	48.69	22,133	100%
190	0.0	72,144	4.1	0.11	0.11	0.00	0.11	0.11	48.69	22,132	100%
192	0.0	72,132	4.1	0.11	0.11	0.00	0.11	0.11	48.69	22,132	100%
194	0.0	72,120	4.1	0.11	0.11	0.00	0.11	0.11	48.69	22,131	100%
196	0.0	72,108	4.1	0.11	0.11	0.00	0.11	0.11	48.69	22,130	100%
198	0.0	72,096	4.1	0.11	0.11	0.00	0.11	0.11	48.68	22,129	100%
200	0.0	72,083	4.1	0.11	0.11	0.00	0.11	0.11	48.68	22,129	100%
202	0.0	72,071	4.1	0.11	0.11	0.00	0.11	0.11	48.68	22,128	100%
204	0.0	72,058	4.1	0.11	0.11	0.00	0.11	0.11	48.68	22,127	100%
206	0.0	72,045	4.1	0.11	0.11	0.00	0.11	0.11	48.68	22,126	100%

**Sediment Basin #1 Colon Mine Phase 1 Hydrograph
10-Yr Storm**

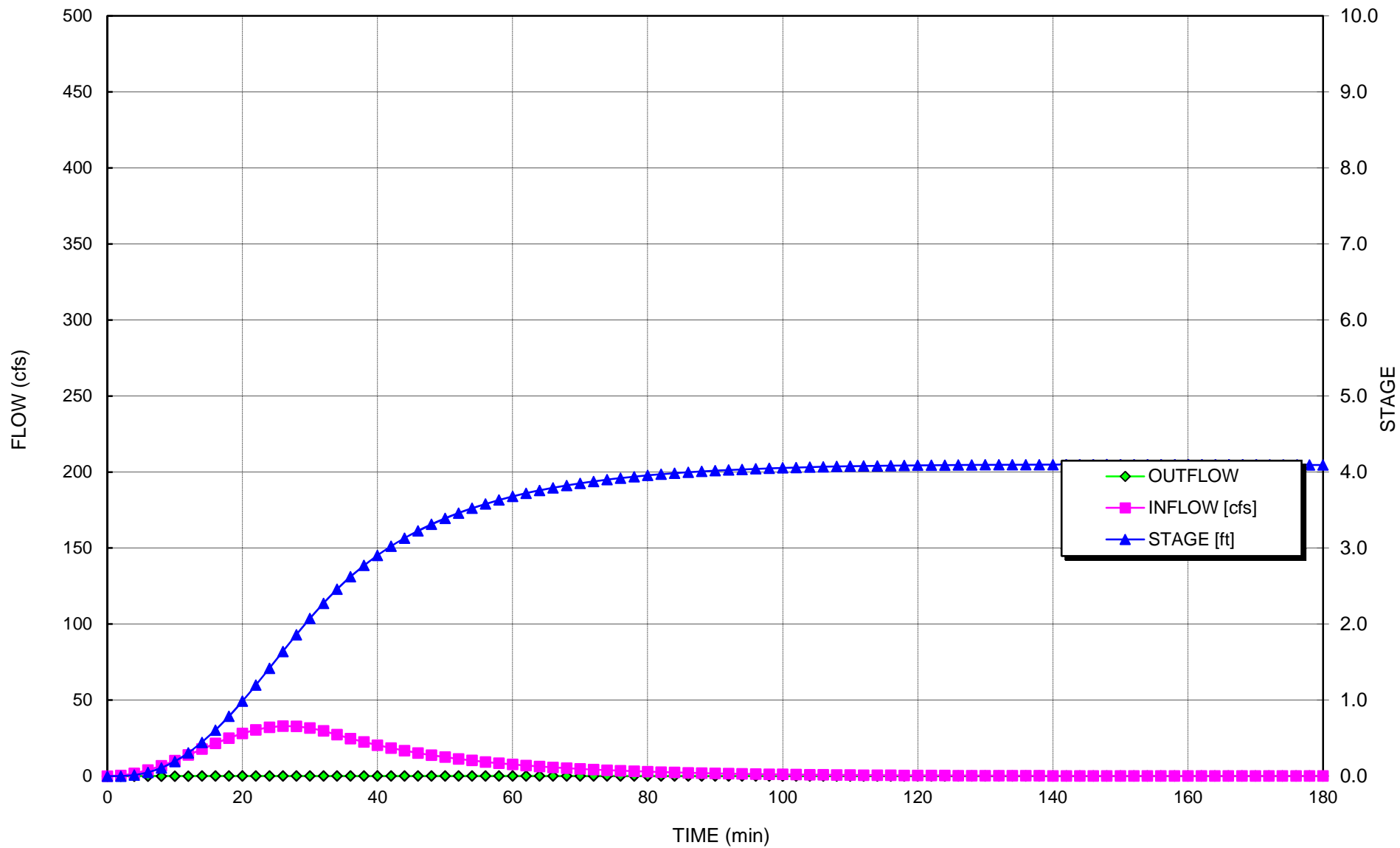

Qp = 43.09 cfs
 Tp = 35.03 minutes
 dT = Max of 2 minutes
 or 1.0% of increment to peak

Sediment Basin # 1 **Colon**
 Phase 2
10 - year Storm Event

b = 1.3
 Ks = 12,318

Number of Riser/Barrel Assemblies = 1
 Diameter of Barrel = 18 (in)
 Height of Riser above barrel = 4.9 (ft)
 Height of Riser from bottom of barrel = 6.4 (ft) elevation 289.40
 Emergency Spillway = 7 (ft) elevation 290.00
 Total Height of Dam = 7.5 (ft) elevation 290.50
 Length of Emergency Spillway = 20 (ft)
 Diameter of Riser = 54 (in)
 Permanent Pond Stage = 0 (ft) elevation 283.0

4.0E-03 Settling Velocity of design particle (fps)
 2 Effective number of cells (2 is construction site #)

100% Minimum Settling Efficiency	
6.3 ft Maximum Stage	289.33 msl elevation
0.1 cfs Peak outflow	
0.1 cfs Peak Riser/Barrel outflow	
0.0 cfs peak weir flow	

Notes:

1. Length of emergency spillway is the bottom width of the emergency spillway.
2. Settling efficiency neglects permanent pond volume

TIME (min)	INFLOW [cfs]	STORAGE [cu ft]	STAGE [ft]	Skimmer Flow [cfs]	RISER CAPACIT Y [cfs]	WEIR FLOW [cfs]	BARREL CAPACIT Y [cfs]	TOTAL OUTFLOW [cfs]	Bound Discharge [cfs]	Estimated Surface Area (sf)	Settling Efficiency [%]
0	0.0	0	0.0	0.00	0.00	0.00	0.00	0.00	0.00	-	N/A
2	0.3	0	0.0	0.00	0.00	0.00	0.00	0.00	0.00	-	N/A
4	1.4	41	0.0	0.00	0.00	0.00	0.00	0.00	10.70	4,864	N/A
6	3.0	206	0.0	0.00	0.00	0.00	0.00	0.00	14.82	6,735	N/A
8	5.3	571	0.1	0.00	0.00	0.00	0.00	0.00	18.23	8,285	N/A
10	8.1	1,209	0.2	0.00	0.00	0.00	0.00	0.00	21.22	9,647	N/A
12	11.3	2,181	0.3	0.00	0.00	0.00	0.00	0.00	23.92	10,875	N/A
14	14.9	3,539	0.4	0.11	0.11	0.00	0.11	0.11	26.40	11,998	100%
16	18.6	5,309	0.5	0.11	0.11	0.00	0.11	0.11	28.66	13,029	100%
18	22.5	7,530	0.7	0.11	0.11	0.00	0.11	0.11	30.77	13,987	100%
20	26.3	10,214	0.9	0.11	0.11	0.00	0.11	0.11	32.74	14,880	100%
22	30.0	13,358	1.1	0.11	0.11	0.00	0.11	0.11	34.57	15,714	100%
24	33.4	16,941	1.3	0.11	0.11	0.00	0.11	0.11	36.28	16,491	100%
26	36.4	20,933	1.5	0.11	0.11	0.00	0.11	0.11	37.87	17,215	100%
28	38.9	25,288	1.8	0.11	0.11	0.00	0.11	0.11	39.35	17,888	100%
30	40.9	29,948	2.0	0.11	0.11	0.00	0.11	0.11	40.73	18,513	100%
32	42.3	34,846	2.3	0.11	0.11	0.00	0.11	0.11	42.00	19,092	100%
34	43.0	39,909	2.6	0.11	0.11	0.00	0.11	0.11	43.18	19,625	100%
36	43.0	45,055	2.8	0.11	0.11	0.00	0.11	0.11	44.25	20,114	100%
38	42.3	50,202	3.1	0.11	0.11	0.00	0.11	0.11	45.23	20,561	100%
40	41.0	55,268	3.3	0.11	0.11	0.00	0.11	0.11	46.13	20,967	100%
42	39.0	60,173	3.5	0.11	0.11	0.00	0.11	0.11	46.93	21,332	100%
44	36.5	64,842	3.8	0.11	0.11	0.00	0.11	0.11	47.65	21,658	100%
46	33.9	69,213	4.0	0.11	0.11	0.00	0.11	0.11	48.28	21,947	100%
48	31.5	73,270	4.1	0.11	0.11	0.00	0.11	0.11	48.84	22,202	100%
50	29.2	77,036	4.3	0.11	0.11	0.00	0.11	0.11	49.34	22,429	100%
52	27.2	80,532	4.5	0.11	0.11	0.00	0.11	0.11	49.79	22,632	100%
54	25.2	83,776	4.6	0.11	0.11	0.00	0.11	0.11	50.19	22,815	100%
56	23.4	86,788	4.7	0.11	0.11	0.00	0.11	0.11	50.55	22,979	100%
58	21.7	89,583	4.9	0.11	0.11	0.00	0.11	0.11	50.88	23,127	100%
60	20.2	92,177	5.0	0.11	0.11	0.00	0.11	0.11	51.18	23,262	100%
62	18.7	94,585	5.1	0.11	0.11	0.00	0.11	0.11	51.44	23,384	100%
64	17.4	96,819	5.2	0.11	0.11	0.00	0.11	0.11	51.69	23,495	100%
66	16.1	98,893	5.3	0.11	0.11	0.00	0.11	0.11	51.91	23,596	100%
68	15.0	100,818	5.3	0.11	0.11	0.00	0.11	0.11	52.12	23,689	100%
70	13.9	102,603	5.4	0.11	0.11	0.00	0.11	0.11	52.30	23,774	100%
72	12.9	104,260	5.5	0.11	0.11	0.00	0.11	0.11	52.47	23,851	100%
74	12.0	105,798	5.5	0.11	0.11	0.00	0.11	0.11	52.63	23,922	100%
76	11.1	107,225	5.6	0.11	0.11	0.00	0.11	0.11	52.77	23,987	100%
78	10.3	108,548	5.7	0.11	0.11	0.00	0.11	0.11	52.90	24,047	100%
80	9.6	109,776	5.7	0.11	0.11	0.00	0.11	0.11	53.02	24,102	100%
82	8.9	110,915	5.8	0.11	0.11	0.00	0.11	0.11	53.14	24,153	100%
84	8.3	111,972	5.8	0.11	0.11	0.00	0.11	0.11	53.24	24,199	100%

86	7.7	112,952	5.8	0.11	0.11	0.00	0.11	0.11	53.33	24,242	100%
88	7.1	113,861	5.9	0.11	0.11	0.00	0.11	0.11	53.42	24,282	100%
90	6.6	114,704	5.9	0.11	0.11	0.00	0.11	0.11	53.50	24,318	100%
92	6.2	115,486	6.0	0.11	0.11	0.00	0.11	0.11	53.57	24,351	100%
94	5.7	116,211	6.0	0.11	0.11	0.00	0.11	0.11	53.64	24,382	100%
96	5.3	116,883	6.0	0.11	0.11	0.00	0.11	0.11	53.70	24,411	100%
98	4.9	117,506	6.0	0.11	0.11	0.00	0.11	0.11	53.76	24,437	100%
100	4.6	118,083	6.1	0.11	0.11	0.00	0.11	0.11	53.82	24,462	100%
102	4.2	118,618	6.1	0.11	0.11	0.00	0.11	0.11	53.87	24,484	100%
104	3.9	119,114	6.1	0.11	0.11	0.00	0.11	0.11	53.91	24,505	100%
106	3.7	119,574	6.1	0.11	0.11	0.00	0.11	0.11	53.95	24,524	100%
108	3.4	119,999	6.1	0.11	0.11	0.00	0.11	0.11	53.99	24,542	100%
110	3.2	120,394	6.2	0.11	0.11	0.00	0.11	0.11	54.03	24,558	100%
112	2.9	120,759	6.2	0.11	0.11	0.00	0.11	0.11	54.06	24,573	100%
114	2.7	121,097	6.2	0.11	0.11	0.00	0.11	0.11	54.09	24,587	100%
116	2.5	121,409	6.2	0.11	0.11	0.00	0.11	0.11	54.12	24,600	100%
118	2.3	121,699	6.2	0.11	0.11	0.00	0.11	0.11	54.15	24,612	100%
120	2.2	121,967	6.2	0.11	0.11	0.00	0.11	0.11	54.17	24,623	100%
122	2.0	122,214	6.2	0.11	0.11	0.00	0.11	0.11	54.19	24,633	100%
124	1.9	122,443	6.2	0.11	0.11	0.00	0.11	0.11	54.21	24,643	100%
126	1.7	122,655	6.2	0.11	0.11	0.00	0.11	0.11	54.23	24,651	100%
128	1.6	122,850	6.3	0.11	0.11	0.00	0.11	0.11	54.25	24,659	100%
130	1.5	123,031	6.3	0.11	0.11	0.00	0.11	0.11	54.27	24,666	100%
132	1.4	123,198	6.3	0.11	0.11	0.00	0.11	0.11	54.28	24,673	100%
134	1.3	123,351	6.3	0.11	0.11	0.00	0.11	0.11	54.29	24,680	100%
136	1.2	123,493	6.3	0.11	0.11	0.00	0.11	0.11	54.31	24,685	100%
138	1.1	123,624	6.3	0.11	0.11	0.00	0.11	0.11	54.32	24,691	100%
140	1.0	123,744	6.3	0.11	0.11	0.00	0.11	0.11	54.33	24,695	100%
142	1.0	123,855	6.3	0.11	0.11	0.00	0.11	0.11	54.34	24,700	100%
144	0.9	123,957	6.3	0.11	0.11	0.00	0.11	0.11	54.35	24,704	100%
146	0.8	124,051	6.3	0.11	0.11	0.00	0.11	0.11	54.36	24,708	100%
148	0.8	124,137	6.3	0.11	0.11	0.00	0.11	0.11	54.36	24,711	100%
150	0.7	124,215	6.3	0.11	0.11	0.00	0.11	0.11	54.37	24,715	100%
152	0.7	124,288	6.3	0.11	0.11	0.00	0.11	0.11	54.38	24,717	100%
154	0.6	124,354	6.3	0.11	0.11	0.00	0.11	0.11	54.38	24,720	100%
156	0.6	124,414	6.3	0.11	0.11	0.00	0.11	0.11	54.39	24,723	100%
158	0.5	124,469	6.3	0.11	0.11	0.00	0.11	0.11	54.39	24,725	100%
160	0.5	124,519	6.3	0.11	0.11	0.00	0.11	0.11	54.40	24,727	100%
162	0.5	124,565	6.3	0.11	0.11	0.00	0.11	0.11	54.40	24,729	100%
164	0.4	124,606	6.3	0.11	0.11	0.00	0.11	0.11	54.41	24,730	100%
166	0.4	124,644	6.3	0.11	0.11	0.00	0.11	0.11	54.41	24,732	100%
168	0.4	124,678	6.3	0.11	0.11	0.00	0.11	0.11	54.41	24,733	100%
170	0.3	124,708	6.3	0.11	0.11	0.00	0.11	0.11	54.42	24,734	100%
172	0.3	124,735	6.3	0.11	0.11	0.00	0.11	0.11	54.42	24,736	100%
174	0.3	124,760	6.3	0.11	0.11	0.00	0.11	0.11	54.42	24,736	100%
176	0.3	124,781	6.3	0.11	0.11	0.00	0.11	0.11	54.42	24,737	100%
178	0.3	124,801	6.3	0.11	0.11	0.00	0.11	0.11	54.42	24,738	100%
180	0.2	124,817	6.3	0.11	0.11	0.00	0.11	0.11	54.43	24,739	100%
182	0.2	124,832	6.3	0.11	0.11	0.00	0.11	0.11	54.43	24,739	100%
184	0.2	124,844	6.3	0.11	0.11	0.00	0.11	0.11	54.43	24,740	100%
186	0.2	124,855	6.3	0.11	0.11	0.00	0.11	0.11	54.43	24,740	100%
188	0.2	124,864	6.3	0.11	0.11	0.00	0.11	0.11	54.43	24,741	100%
190	0.2	124,872	6.3	0.11	0.11	0.00	0.11	0.11	54.43	24,741	100%
192	0.2	124,877	6.3	0.11	0.11	0.00	0.11	0.11	54.43	24,741	100%
194	0.1	124,882	6.3	0.11	0.11	0.00	0.11	0.11	54.43	24,741	100%
196	0.1	124,885	6.3	0.11	0.11	0.00	0.11	0.11	54.43	24,742	100%
198	0.1	124,887	6.3	0.11	0.11	0.00	0.11	0.11	54.43	24,742	100%
200	0.1	124,888	6.3	0.11	0.11	0.00	0.11	0.11	54.43	24,742	100%
202	0.1	124,888	6.3	0.11	0.11	0.00	0.11	0.11	54.43	24,742	100%
204	0.1	124,887	6.3	0.11	0.11	0.00	0.11	0.11	54.43	24,742	100%

Sediment Basin #1 Colon Mine Phase 2 Hydrograph 10-Yr Storm

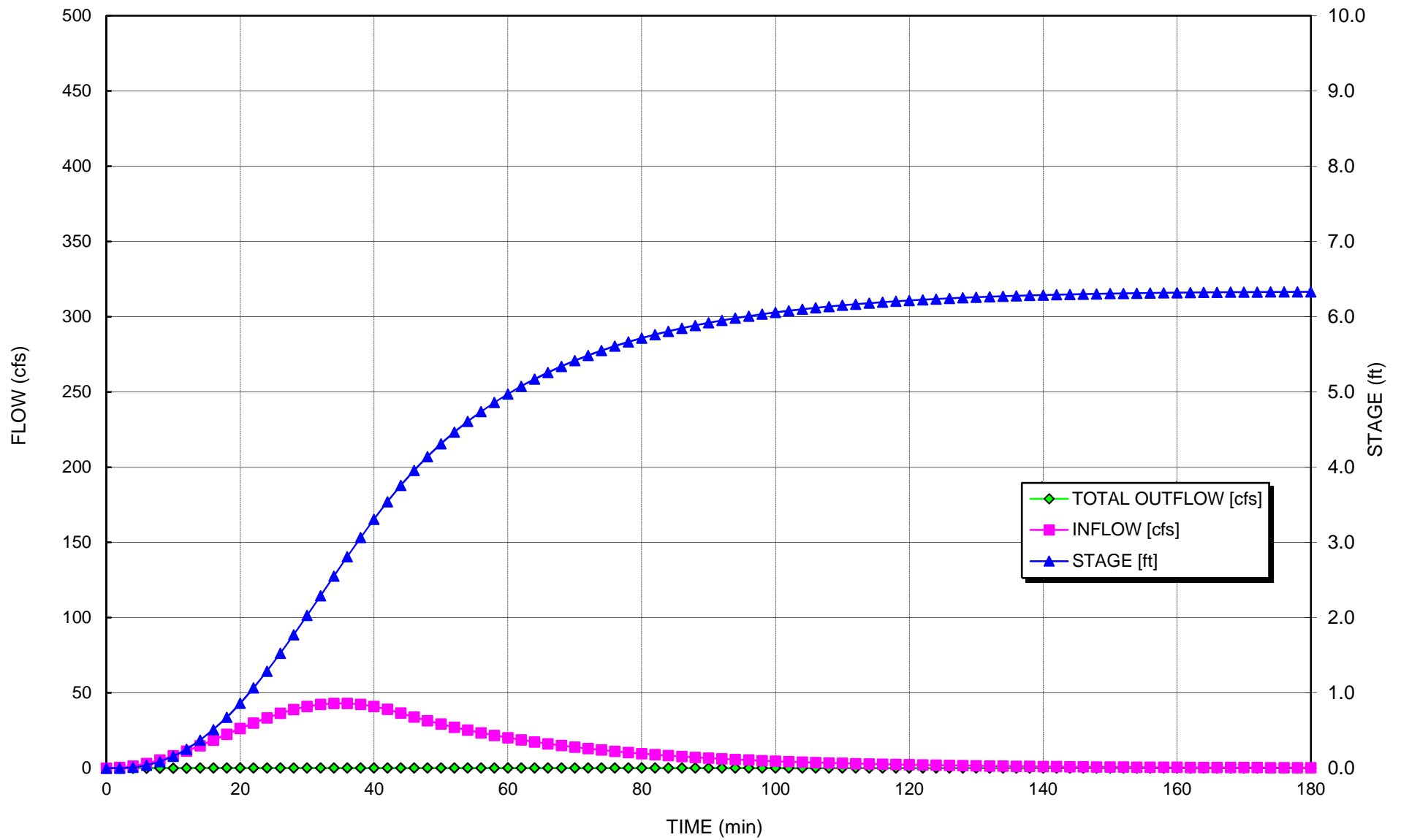

Qp = 53.49 cfs
 Tp = 35.39 minutes
 dT = Max of 2 minutes
 or 1.0% of increment to peak

Sediment Basin # 1 **Colon**
 Phase 2
25 - year Storm Event

b = 1.3
 Ks = 12,318

Number of Riser/Barrel Assemblies = 1
 Diameter of Barrel = 18 (in)
 Height of Riser above barrel = 4.9 (ft)
 Height of Riser from bottom of barrel = 6.4 (ft) elevation 289.40
 Emergency Spillway = 7.0 (ft) elevation 290.00
 Total Height of Dam = 7.5 (ft) elevation 290.50
 Length of Emergency Spillway = 20 (ft)
 Diameter of Riser = 54 (in)
 Permanent Pond Stage = 0 (ft) elevation 283.0

4.0E-03 Settling Velocity of design particle (fps)

2 Effective number of cells (2 is construction site #)

97% Minimum Settling Efficiency	
6.8 ft Maximum Stage	289.8 msl elevation
10.0 cfs Peak outflow	
10.0 cfs Peak Riser/Barrel outflow	
0.0 cfs peak weir flow	

Notes:

1. Length of emergency spillway is the bottom width of the emergency spillway.
2. Settling efficiency neglects permanent pond volume

TIME (min)	INFLOW [cfs]	STORAGE [cu ft]	STAGE [ft]	Skimmer Flow [cfs]	RISER CAPACIT Y [cfs]	WEIR FLOW [cfs]	BARREL CAPACITY [cfs]	TOTAL OUTFL OW [cfs]	Bound Discharge [cfs]	Estimated Surface Area (sf)	Settling Efficiency [%]
0	0.0	0	0.0	0.00	0.00	0.00	0.00	0.00	0.00	-	N/A
2	0.4	0	0.0	0.00	0.00	0.00	0.00	0.00	0.00	-	N/A
4	1.7	50	0.0	0.00	0.00	0.00	0.00	0.00	11.13	5,061	N/A
6	3.7	251	0.0	0.00	0.00	0.00	0.00	0.00	15.42	7,009	N/A
8	6.5	695	0.1	0.00	0.00	0.00	0.00	0.00	18.97	8,622	N/A
10	9.9	1,471	0.2	0.00	0.00	0.00	0.00	0.00	22.09	10,040	N/A
12	13.8	2,655	0.3	0.00	0.00	0.00	0.00	0.00	24.90	11,319	N/A
14	18.1	4,311	0.4	0.11	0.11	0.00	0.11	0.11	27.48	12,489	100%
16	22.7	6,473	0.6	0.11	0.11	0.00	0.11	0.11	29.84	13,564	100%
18	27.5	9,188	0.8	0.11	0.11	0.00	0.11	0.11	32.04	14,564	100%
20	32.2	12,472	1.0	0.11	0.11	0.00	0.11	0.11	34.09	15,496	100%
22	36.7	16,320	1.3	0.11	0.11	0.00	0.11	0.11	36.01	16,366	100%
24	41.0	20,714	1.5	0.11	0.11	0.00	0.11	0.11	37.79	17,178	100%
26	44.7	25,614	1.8	0.11	0.11	0.00	0.11	0.11	39.46	17,935	100%
28	47.9	30,968	2.1	0.11	0.11	0.00	0.11	0.11	41.01	18,640	100%
30	50.5	36,708	2.4	0.11	0.11	0.00	0.11	0.11	42.45	19,295	100%
32	52.3	42,753	2.7	0.11	0.11	0.00	0.11	0.11	43.78	19,901	100%
34	53.3	49,015	3.0	0.11	0.11	0.00	0.11	0.11	45.02	20,461	100%
36	53.5	55,396	3.3	0.11	0.11	0.00	0.11	0.11	46.15	20,976	100%
38	52.8	61,796	3.6	0.11	0.11	0.00	0.11	0.11	47.18	21,447	100%
40	51.3	68,115	3.9	0.11	0.11	0.00	0.11	0.11	48.13	21,876	100%
42	49.0	74,255	4.2	0.11	0.11	0.00	0.11	0.11	48.98	22,262	100%
44	46.0	80,122	4.4	0.11	0.11	0.00	0.11	0.11	49.74	22,609	100%
46	42.8	85,634	4.7	0.11	0.11	0.00	0.11	0.11	50.42	22,917	100%
48	39.8	90,761	4.9	0.11	0.11	0.00	0.11	0.11	51.02	23,189	100%
50	37.0	95,524	5.1	0.11	0.11	0.00	0.11	0.11	51.55	23,431	100%
52	34.4	99,948	5.3	0.11	0.11	0.00	0.11	0.11	52.02	23,647	100%
54	31.9	104,058	5.5	0.11	0.11	0.00	0.11	0.11	52.45	23,842	100%
56	29.7	107,876	5.6	0.11	0.11	0.00	0.11	0.11	52.84	24,017	100%
58	27.6	111,422	5.8	0.11	0.11	0.00	0.11	0.11	53.18	24,175	100%
60	25.6	114,717	5.9	0.11	0.11	0.00	0.11	0.11	53.50	24,318	100%
62	23.8	117,777	6.0	0.11	0.11	0.00	0.11	0.11	53.79	24,449	100%
64	22.1	120,619	6.2	0.11	0.11	0.00	0.11	0.11	54.05	24,568	100%
66	20.5	123,259	6.3	0.11	0.11	0.00	0.11	0.11	54.29	24,676	100%
68	19.1	125,711	6.4	0.11	0.11	0.00	0.11	0.11	54.50	24,775	100%
70	17.7	127,988	6.5	0.11	0.78	0.00	20.30	0.78	54.70	24,865	100%
72	16.5	130,023	6.5	0.11	2.58	0.00	20.44	2.58	54.88	24,945	100%
74	15.3	131,691	6.6	0.11	4.52	0.00	20.56	4.52	55.02	25,010	99%
76	14.2	132,986	6.7	0.11	6.27	0.00	20.65	6.27	55.13	25,059	99%
78	13.2	133,941	6.7	0.11	7.68	0.00	20.72	7.68	55.21	25,096	98%
80	12.3	134,607	6.7	0.11	8.71	0.00	20.76	8.71	55.27	25,121	98%
82	11.4	135,036	6.7	0.11	9.40	0.00	20.79	9.40	55.30	25,137	98%
84	10.6	135,278	6.8	0.11	9.79	0.00	20.81	9.79	55.32	25,146	97%

86	9.9	135,375	6.8	0.11	9.95	0.00	20.82	9.95	55.33	25,150	97%
88	9.2	135,363	6.8	0.11	9.93	0.00	20.82	9.93	55.33	25,150	97%
90	8.5	135,269	6.8	0.11	9.78	0.00	20.81	9.78	55.32	25,146	97%
92	7.9	135,117	6.7	0.11	9.53	0.00	20.80	9.53	55.31	25,140	97%
94	7.3	134,922	6.7	0.11	9.21	0.00	20.79	9.21	55.29	25,133	98%
96	6.8	134,697	6.7	0.11	8.85	0.00	20.77	8.85	55.27	25,125	98%
98	6.3	134,454	6.7	0.11	8.47	0.00	20.75	8.47	55.25	25,115	98%
100	5.9	134,199	6.7	0.11	8.07	0.00	20.74	8.07	55.23	25,106	98%
102	5.5	133,937	6.7	0.11	7.67	0.00	20.72	7.67	55.21	25,096	98%
104	5.1	133,674	6.7	0.11	7.27	0.00	20.70	7.27	55.19	25,086	98%
106	4.7	133,411	6.7	0.11	6.88	0.00	20.68	6.88	55.17	25,076	99%
108	4.4	133,152	6.7	0.11	6.51	0.00	20.66	6.51	55.14	25,066	99%
110	4.1	132,898	6.7	0.11	6.15	0.00	20.64	6.15	55.12	25,056	99%
112	3.8	132,650	6.6	0.11	5.80	0.00	20.63	5.80	55.10	25,047	99%
114	3.5	132,410	6.6	0.11	5.47	0.00	20.61	5.47	55.08	25,037	99%
116	3.3	132,176	6.6	0.11	5.15	0.00	20.59	5.15	55.06	25,028	99%
118	3.0	131,950	6.6	0.11	4.86	0.00	20.58	4.86	55.04	25,020	99%
120	2.8	131,732	6.6	0.11	4.58	0.00	20.56	4.58	55.02	25,011	99%
122	2.6	131,522	6.6	0.11	4.31	0.00	20.55	4.31	55.01	25,003	99%
124	2.4	131,320	6.6	0.11	4.06	0.00	20.53	4.06	54.99	24,995	99%
126	2.3	131,126	6.6	0.11	3.82	0.00	20.52	3.82	54.97	24,988	99%
128	2.1	130,940	6.6	0.11	3.60	0.00	20.51	3.60	54.96	24,981	100%
130	2.0	130,760	6.6	0.11	3.39	0.00	20.50	3.39	54.94	24,974	100%
132	1.8	130,588	6.6	0.11	3.19	0.00	20.48	3.19	54.93	24,967	100%
134	1.7	130,423	6.6	0.11	3.01	0.00	20.47	3.01	54.91	24,961	100%
136	1.6	130,265	6.6	0.11	2.83	0.00	20.46	2.83	54.90	24,954	100%
138	1.5	130,113	6.5	0.11	2.67	0.00	20.45	2.67	54.89	24,948	100%
140	1.4	129,968	6.5	0.11	2.52	0.00	20.44	2.52	54.87	24,943	100%
142	1.3	129,828	6.5	0.11	2.37	0.00	20.43	2.37	54.86	24,937	100%
144	1.2	129,695	6.5	0.11	2.24	0.00	20.42	2.24	54.85	24,932	100%
146	1.1	129,566	6.5	0.11	2.11	0.00	20.41	2.11	54.84	24,927	100%
148	1.0	129,444	6.5	0.11	1.99	0.00	20.40	1.99	54.83	24,922	100%
150	0.9	129,326	6.5	0.11	1.88	0.00	20.39	1.88	54.82	24,918	100%
152	0.9	129,213	6.5	0.11	1.77	0.00	20.39	1.77	54.81	24,913	100%
154	0.8	129,105	6.5	0.11	1.67	0.00	20.38	1.67	54.80	24,909	100%
156	0.8	129,001	6.5	0.11	1.58	0.00	20.37	1.58	54.79	24,905	100%
158	0.7	128,902	6.5	0.11	1.49	0.00	20.36	1.49	54.78	24,901	100%
160	0.7	128,806	6.5	0.11	1.41	0.00	20.36	1.41	54.77	24,897	100%
162	0.6	128,715	6.5	0.11	1.34	0.00	20.35	1.34	54.77	24,894	100%
164	0.6	128,627	6.5	0.11	1.26	0.00	20.34	1.26	54.76	24,890	100%
166	0.5	128,543	6.5	0.11	1.19	0.00	20.34	1.19	54.75	24,887	100%
168	0.5	128,462	6.5	0.11	1.13	0.00	20.33	1.13	54.74	24,884	100%
170	0.5	128,384	6.5	0.11	1.07	0.00	20.33	1.07	54.74	24,881	100%
172	0.4	128,310	6.5	0.11	1.01	0.00	20.32	1.01	54.73	24,878	100%
174	0.4	128,239	6.5	0.11	0.96	0.00	20.32	0.96	54.73	24,875	100%
176	0.4	128,170	6.5	0.11	0.91	0.00	20.31	0.91	54.72	24,872	100%
178	0.3	128,104	6.5	0.11	0.86	0.00	20.31	0.86	54.71	24,870	100%
180	0.3	128,041	6.5	0.11	0.82	0.00	20.30	0.82	54.71	24,867	100%
182	0.3	127,980	6.5	0.11	0.78	0.00	20.30	0.78	54.70	24,865	100%
184	0.3	127,922	6.5	0.11	0.74	0.00	20.29	0.74	54.70	24,863	100%
186	0.3	127,866	6.5	0.11	0.70	0.00	20.29	0.70	54.69	24,860	100%
188	0.2	127,812	6.5	0.11	0.66	0.00	20.29	0.66	54.69	24,858	100%
190	0.2	127,760	6.4	0.11	0.63	0.00	20.28	0.63	54.68	24,856	100%
192	0.2	127,710	6.4	0.11	0.60	0.00	20.28	0.60	54.68	24,854	100%
194	0.2	127,662	6.4	0.11	0.57	0.00	20.27	0.57	54.68	24,852	100%
196	0.2	127,616	6.4	0.11	0.54	0.00	20.27	0.54	54.67	24,850	100%
198	0.2	127,571	6.4	0.11	0.52	0.00	20.27	0.52	54.67	24,849	100%
200	0.1	127,528	6.4	0.11	0.49	0.00	20.27	0.49	54.66	24,847	100%
202	0.1	127,487	6.4	0.11	0.47	0.00	20.26	0.47	54.66	24,845	100%
204	0.1	127,447	6.4	0.11	0.45	0.00	20.26	0.45	54.66	24,844	100%
206	0.1	127,409	6.4	0.11	0.43	0.00	20.26	0.43	54.65	24,842	100%

**Sediment Basin #1 Colon Mine Phase 2 Hydrograph
25-Yr Storm**

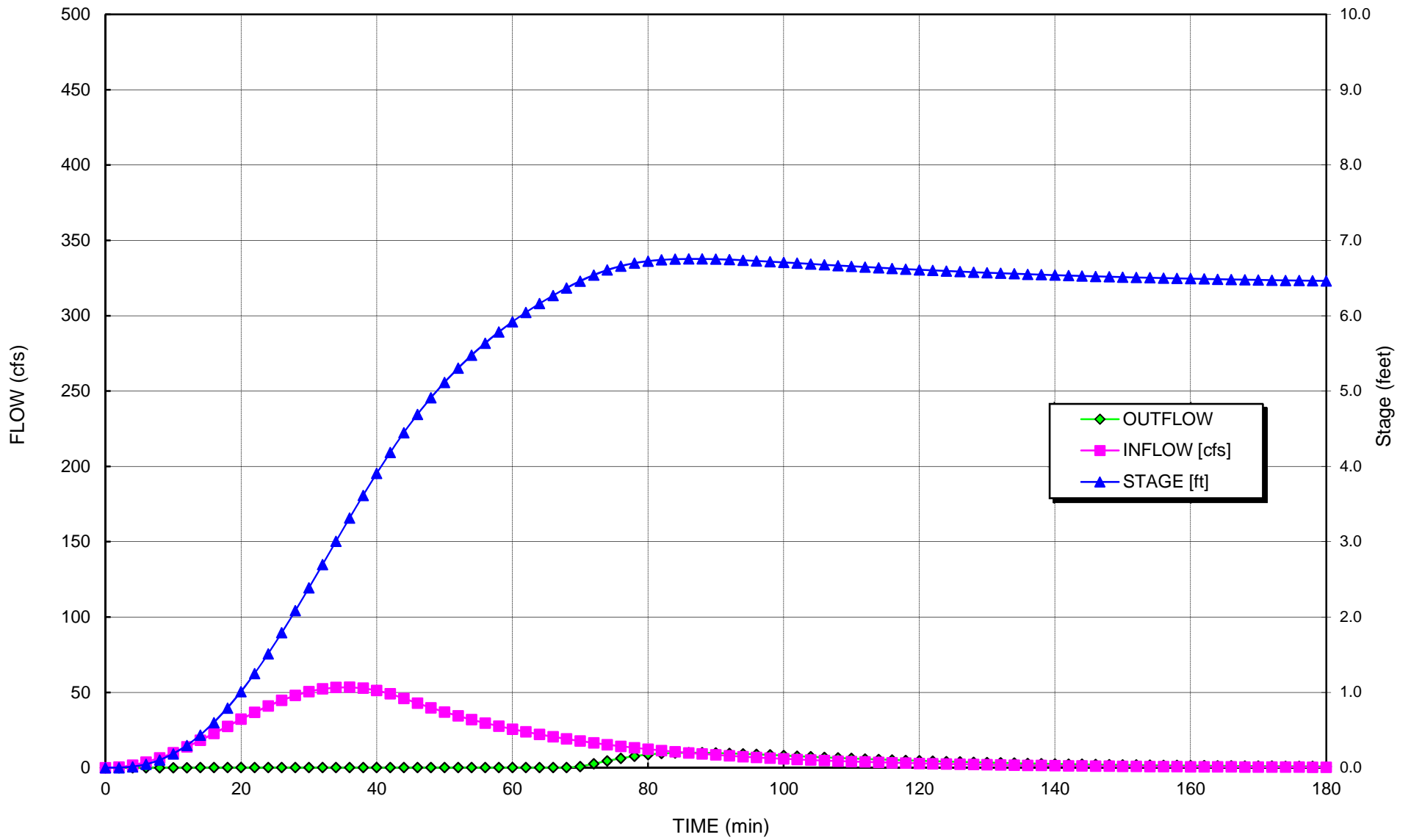

Qp = 70.1 cfs
 Tp = 35.9 minutes
 dT = Max of 2 minutes
 or 1.0% of increment to peak

Sediment Basin # 1 **Colon**
 Phase 2
100 - year Storm Event

b = 1.3
 Ks = 12,318

Number of Riser/Barrel Assemblies = 1
 Diameter of Barrel = 18 (in)
 Height of Riser above barrel = 4.9 (ft)
 Height of Riser from bottom of barrel = 6.4 (ft) elevation 289.40
 Emergency Spillway = 7.0 (ft) elevation 290.00
 Total Height of Dam = 7.5 (ft) elevation 290.50
 Length of Emergency Spillway = 20 (ft)
 Diameter of Riser = 54 (in)
 Permanent Pond Stage = 0 (ft) elevation 283.0

4.0E-03 Settling Velocity of design particle (fps)
 2 Effective number of cells (2 is construction site #)

88% Minimum Settling Efficiency	
7.2 ft Maximum Stage	290.2 msl elevation
27.4 cfs Peak outflow	
21.6 cfs Peak Riser/Barrel outflow	
5.8 cfs peak weir flow	

Notes:

1. Length of emergency spillway is the bottom width of the emergency spillway.
2. Settling efficiency neglects permanent pond volume

TIME (min)	INFLOW [cfs]	STORAGE [cu ft]	STAGE [ft]	Skimmer Flow [cfs]	RISER CAPACIT Y [cfs]	WEIR FLOW [cfs]	BARREL CAPACITY [cfs]	TOTAL OUTFLOW [cfs]	Bound Discharge [cfs]	Estimated Surface Area (sf)	Settling Efficiency [%]
0	0.0	0	0.0	0.00	0.00	0.00	0.00	0.00	0.00	-	N/A
2	0.5	0	0.0	0.00	0.00	0.00	0.00	0.00	0.00	-	N/A
4	2.1	64	0.0	0.00	0.00	0.00	0.00	0.00	11.69	5,315	N/A
6	4.7	319	0.1	0.00	0.00	0.00	0.00	0.00	16.19	7,361	N/A
8	8.2	885	0.1	0.00	0.00	0.00	0.00	0.00	19.92	9,056	N/A
10	12.6	1,874	0.2	0.00	0.00	0.00	0.00	0.00	23.20	10,545	N/A
12	17.6	3,383	0.4	0.11	0.11	0.00	0.11	0.11	26.16	11,889	100%
14	23.2	5,482	0.5	0.11	0.11	0.00	0.11	0.11	28.85	13,114	100%
16	29.1	8,248	0.7	0.11	0.11	0.00	0.11	0.11	31.35	14,248	100%
18	35.2	11,724	1.0	0.11	0.11	0.00	0.11	0.11	33.67	15,303	100%
20	41.3	15,932	1.2	0.11	0.11	0.00	0.11	0.11	35.83	16,286	100%
22	47.2	20,872	1.5	0.11	0.11	0.00	0.11	0.11	37.85	17,204	100%
24	52.7	26,521	1.8	0.11	0.11	0.00	0.11	0.11	39.74	18,062	100%
26	57.7	32,834	2.2	0.11	0.11	0.00	0.11	0.11	41.50	18,863	100%
28	62.0	39,747	2.5	0.11	0.11	0.00	0.11	0.11	43.14	19,609	100%
30	65.5	47,175	2.9	0.11	0.11	0.00	0.11	0.11	44.67	20,303	100%
32	68.0	55,022	3.3	0.11	0.11	0.00	0.11	0.11	46.08	20,948	100%
34	69.6	63,174	3.7	0.11	0.11	0.00	0.11	0.11	47.40	21,544	100%
36	70.1	71,510	4.1	0.11	0.11	0.00	0.11	0.11	48.60	22,093	100%
38	69.5	79,905	4.4	0.11	0.11	0.00	0.11	0.11	49.71	22,596	100%
40	67.8	88,229	4.8	0.11	0.11	0.00	0.11	0.11	50.72	23,056	100%
42	65.2	96,357	5.2	0.11	0.11	0.00	0.11	0.11	51.64	23,472	100%
44	61.6	104,168	5.5	0.11	0.11	0.00	0.11	0.11	52.46	23,847	100%
46	57.5	111,551	5.8	0.11	0.11	0.00	0.11	0.11	53.20	24,181	100%
48	53.5	118,437	6.1	0.11	0.11	0.00	0.11	0.11	53.85	24,477	100%
50	49.7	124,842	6.3	0.11	0.11	0.00	0.11	0.11	54.43	24,740	100%
52	46.3	130,798	6.6	0.11	3.43	0.00	20.50	3.43	54.95	24,975	100%
54	43.0	135,939	6.8	0.11	10.90	0.00	20.86	10.90	55.38	25,171	97%
56	40.0	139,795	6.9	0.11	18.09	0.00	21.12	18.09	55.69	25,315	93%
58	37.2	142,428	7.0	0.11	23.63	0.37	21.29	21.66	55.90	25,411	91%
60	34.6	144,298	7.1	0.11	27.84	2.10	21.42	23.51	56.05	25,478	90%
62	32.2	145,632	7.2	0.11	30.97	3.81	21.51	25.32	56.16	25,526	89%
64	30.0	146,460	7.2	0.11	32.97	5.03	21.56	26.59	56.22	25,555	88%
66	27.9	146,865	7.2	0.11	33.96	5.67	21.59	27.26	56.25	25,570	88%
68	25.9	146,939	7.2	0.11	34.14	5.79	21.59	27.38	56.26	25,572	88%
70	24.1	146,765	7.2	0.11	33.71	5.51	21.58	27.09	56.25	25,566	88%
72	22.4	146,408	7.2	0.11	32.84	4.95	21.56	26.51	56.22	25,553	88%
74	20.9	145,918	7.2	0.11	31.66	4.22	21.53	25.75	56.18	25,536	89%
76	19.4	145,332	7.1	0.11	30.26	3.40	21.49	24.88	56.13	25,515	89%
78	18.1	144,675	7.1	0.11	28.71	2.55	21.44	23.99	56.08	25,492	90%
80	16.8	143,962	7.1	0.11	27.07	1.72	21.40	23.12	56.03	25,466	90%
82	15.6	143,203	7.1	0.11	25.35	0.97	21.35	22.31	55.97	25,439	91%
84	14.5	142,399	7.0	0.11	23.57	0.35	21.29	21.64	55.90	25,410	91%

86	13.5	141,546	7.0	0.11	21.72	0.00	21.24	21.24	55.83	25,379	91%
88	12.6	140,619	7.0	0.11	19.77	0.00	21.17	19.77	55.76	25,345	92%
90	11.7	139,754	6.9	0.11	18.01	0.00	21.12	18.01	55.69	25,313	93%
92	10.9	138,996	6.9	0.11	16.51	0.00	21.06	16.51	55.63	25,285	94%
94	10.1	138,320	6.9	0.11	15.20	0.00	21.02	15.20	55.57	25,260	95%
96	9.4	137,709	6.8	0.11	14.06	0.00	20.98	14.06	55.52	25,238	95%
98	8.7	137,151	6.8	0.11	13.03	0.00	20.94	13.03	55.48	25,217	96%
100	8.1	136,637	6.8	0.11	12.12	0.00	20.90	12.12	55.43	25,198	96%
102	7.6	136,160	6.8	0.11	11.28	0.00	20.87	11.28	55.40	25,180	97%
104	7.0	135,714	6.8	0.11	10.52	0.00	20.84	10.52	55.36	25,163	97%
106	6.5	135,296	6.8	0.11	9.83	0.00	20.81	9.83	55.32	25,147	97%
108	6.1	134,903	6.7	0.11	9.18	0.00	20.78	9.18	55.29	25,132	98%
110	5.7	134,532	6.7	0.11	8.59	0.00	20.76	8.59	55.26	25,118	98%
112	5.3	134,181	6.7	0.11	8.04	0.00	20.73	8.04	55.23	25,105	98%
114	4.9	133,848	6.7	0.11	7.54	0.00	20.71	7.54	55.20	25,092	98%
116	4.6	133,532	6.7	0.11	7.06	0.00	20.69	7.06	55.18	25,080	98%
118	4.2	133,232	6.7	0.11	6.62	0.00	20.67	6.62	55.15	25,069	99%
120	3.9	132,946	6.7	0.11	6.21	0.00	20.65	6.21	55.13	25,058	99%
122	3.7	132,674	6.6	0.11	5.83	0.00	20.63	5.83	55.10	25,047	99%
124	3.4	132,414	6.6	0.11	5.48	0.00	20.61	5.48	55.08	25,037	99%
126	3.2	132,167	6.6	0.11	5.14	0.00	20.59	5.14	55.06	25,028	99%
128	3.0	131,931	6.6	0.11	4.83	0.00	20.58	4.83	55.04	25,019	99%
130	2.7	131,705	6.6	0.11	4.54	0.00	20.56	4.54	55.02	25,010	99%
132	2.6	131,490	6.6	0.11	4.27	0.00	20.55	4.27	55.00	25,002	99%
134	2.4	131,284	6.6	0.11	4.01	0.00	20.53	4.01	54.99	24,994	99%
136	2.2	131,088	6.6	0.11	3.78	0.00	20.52	3.78	54.97	24,986	100%
138	2.1	130,900	6.6	0.11	3.55	0.00	20.50	3.55	54.95	24,979	100%
140	1.9	130,720	6.6	0.11	3.34	0.00	20.49	3.34	54.94	24,972	100%
142	1.8	130,548	6.6	0.11	3.15	0.00	20.48	3.15	54.92	24,965	100%
144	1.7	130,384	6.6	0.11	2.96	0.00	20.47	2.96	54.91	24,959	100%
146	1.5	130,227	6.5	0.11	2.79	0.00	20.46	2.79	54.90	24,953	100%
148	1.4	130,076	6.5	0.11	2.63	0.00	20.45	2.63	54.88	24,947	100%
150	1.3	129,932	6.5	0.11	2.48	0.00	20.44	2.48	54.87	24,941	100%
152	1.2	129,794	6.5	0.11	2.34	0.00	20.43	2.34	54.86	24,936	100%
154	1.2	129,662	6.5	0.11	2.21	0.00	20.42	2.21	54.85	24,931	100%
156	1.1	129,536	6.5	0.11	2.08	0.00	20.41	2.08	54.84	24,926	100%
158	1.0	129,415	6.5	0.11	1.96	0.00	20.40	1.96	54.83	24,921	100%
160	0.9	129,299	6.5	0.11	1.85	0.00	20.39	1.85	54.82	24,917	100%
162	0.9	129,187	6.5	0.11	1.75	0.00	20.38	1.75	54.81	24,912	100%
164	0.8	129,081	6.5	0.11	1.65	0.00	20.38	1.65	54.80	24,908	100%
166	0.7	128,979	6.5	0.11	1.56	0.00	20.37	1.56	54.79	24,904	100%
168	0.7	128,881	6.5	0.11	1.48	0.00	20.36	1.48	54.78	24,900	100%
170	0.6	128,787	6.5	0.11	1.40	0.00	20.36	1.40	54.77	24,897	100%
172	0.6	128,697	6.5	0.11	1.32	0.00	20.35	1.32	54.76	24,893	100%
174	0.6	128,610	6.5	0.11	1.25	0.00	20.34	1.25	54.76	24,890	100%
176	0.5	128,527	6.5	0.11	1.18	0.00	20.34	1.18	54.75	24,886	100%
178	0.5	128,448	6.5	0.11	1.12	0.00	20.33	1.12	54.74	24,883	100%
180	0.4	128,371	6.5	0.11	1.06	0.00	20.33	1.06	54.74	24,880	100%
182	0.4	128,298	6.5	0.11	1.00	0.00	20.32	1.00	54.73	24,877	100%
184	0.4	128,228	6.5	0.11	0.95	0.00	20.32	0.95	54.72	24,875	100%
186	0.4	128,160	6.5	0.11	0.90	0.00	20.31	0.90	54.72	24,872	100%
188	0.3	128,095	6.5	0.11	0.86	0.00	20.31	0.86	54.71	24,869	100%
190	0.3	128,033	6.5	0.11	0.81	0.00	20.30	0.81	54.71	24,867	100%
192	0.3	127,973	6.5	0.11	0.77	0.00	20.30	0.77	54.70	24,865	100%
194	0.3	127,915	6.5	0.11	0.73	0.00	20.29	0.73	54.70	24,862	100%
196	0.3	127,860	6.5	0.11	0.70	0.00	20.29	0.70	54.69	24,860	100%
198	0.2	127,806	6.5	0.11	0.66	0.00	20.29	0.66	54.69	24,858	100%
200	0.2	127,755	6.4	0.11	0.63	0.00	20.28	0.63	54.68	24,856	100%
202	0.2	127,706	6.4	0.11	0.60	0.00	20.28	0.60	54.68	24,854	100%
204	0.2	127,658	6.4	0.11	0.57	0.00	20.27	0.57	54.67	24,852	100%

**Sediment Basin #1 Colon Mine Phase 2 Hydrograph
100-Yr Storm**

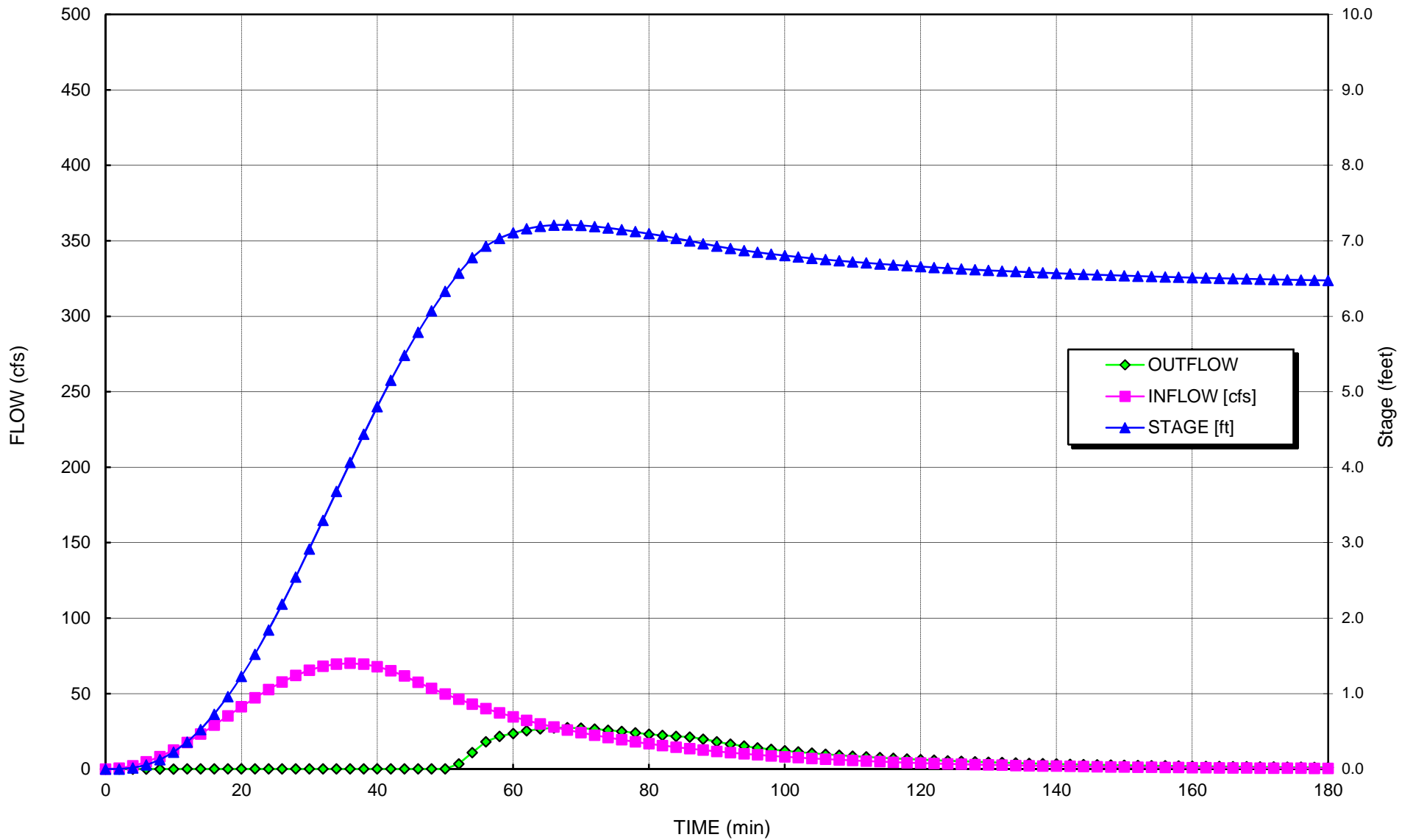

Project:	Charah Colon Mine	Computed:	EAW	Date:	1/4/15
Subject:	Permit Application	Checked:	PAW	Date:	1/4/15
Task:	Sediment Basin #2	Sheet:	1	Of:	4

Objective Design the sediment basin to contain the 10-year storm and pass the 100-year storm without over topping the berm.

References

1. NC Erosion and Sediment Control Planning and Design Manual.
2. "Elements of Urban Stormwater Design" by H. Rooney Malcom, P.E.
3. VA Erosion and Sediment Control Handbook
3. NOAA Atlas 14, Volume 2, Version 3

Given

	Phase	1	2	2	2		
Storm Event (yrs) =		10	10	25	100		
Total Drainage Area A (ac) =		17.6	14.8	14.8	14.8		
Disturbed Area (ac) =		17.6	14.8	14.8	14.8		
Curve Number CN =		86	87	87	87	Hydrographs	
Rainfall Depth P (in) =		5.28	5.28	6.28	7.88	(24-hr rainfall)	Ref 3
Peak Flow Q _p (cfs) =		101.32	79.90	98.71	128.64	Hydrographs	

Design Criteria

Required sediment storage	1,800	cf / acre of drainage
Required sediment storage	31,680	cf (based on largest Phase)
Required Surface Area	435	sf/cfs of the 10-yr storm peak flow (based on the largest Phase in cfs)
Required Surface Area (SF)	44,074	of the 10-yr storm peak flow (based on the largest Phase)

Determine Shape of Basin:

Measure the area of the Basin using AutoCADD.

Calculate Volume of the Basin using Truncated Pyramid Method.

Shape factor used in hydrographs basin depth may be greater than indicated below

Elevation (ft)	Depth (ft)	Area (sf)	Volume (cf)	Cumulative Vol (cf)	Cumulative Vol (cy)
259	0	0	-	-	-
259	0	37,790	0	0	0
260	1	40,921	39,345	39,345	1,457
261	2	44,109	42,505	81,850	3,031
262	3	47,355	45,722	127,573	4,725
263	4	50,658	48,997	176,570	6,540
264	5	54,018	52,329	228,899	8,478
265	6	57,435	55,718	284,617	10,541

Design Sediment Depth (ft) = 3

Sediment Storage (cf) = 127,573

Required Sediment Storage Achieved

Design Surface Area Depth (ft) = 3

Surface Area (sf) = 47,355

Required Surface Area Achieved

Project: Charah Colon Mine	Computed: EAW	Date: 1/4/15
Subject: Permit Application	Checked: PAW	Date: 1/4/15
Task: Sediment Basin #2	Sheet: 2	Of: 4

Select Skimmer

A. R. Jarrett Method

$$D = [Q / (2,310 * (H^{0.5}))]^{0.5}$$

D = Diameter of Orifice (inches)
 Q = Dewater Rate (cf/day)
 H = Head on orifice, varies based on skimmer size (ft)

Skimmer Sizes (Inches)	Head (ft)
1.5	0.125
2	0.167
2.5	0.167
3	0.250
4	0.333
5	0.333
6	0.417
8	0.500

Volume to Dewater (cf) =	127,573		
Number of Skimmers	2		
Days to Drain =	5	<i>assumed</i>	
Q each (cf/day) =	12,757		0.15 cfs
Selected Skimmer Size (inches) =	4		
Head on Skimmer (feet) =	0.333		
Diameter of Orifice (inches) =	3.1		

Route the flow through the Basin

Riser is not perforated, but skimmer is attached.

$$S = (1000/CN) - 10$$

$$\text{Runoff Depth } Q^* \text{ (inches)} = (P-0.2S)^2 / (P+0.8S)$$

$$T_p \text{ (min)} = 60.5(Q^*)A/Q_p / 1.39$$

Ref 2, III-4

Phase	1	2	2	2
Storm Event (yrs) =	10	10	25	100
S =	1.63	1.49	1.49	1.49
Runoff Depth Q* (inches) =	3.73	3.83	4.79	6.33
Time to Peak T _p (min) =	28.19	30.89	31.23	31.71

Determine Pond Storage Elevation (Z_{water}):

Pick one point near max expected water surface and the other at the mid depth.

$$Z_1 \text{ (ft)} = 3 \quad S_1 \text{ (cf)} = 127,573$$

$$Z_2 \text{ (ft)} = 6 \quad S_2 \text{ (cf)} = 284,617$$

$$b = \ln(S_2/S_1) / \ln(Z_2/Z_1) = 1.2$$

$$K_S = S_2 / Z_2^b = 35,760$$

Ref 2, III-8

Project: Charah Colon Mine	Computed: EAW	Date: 1/4/15
Subject: Permit Application	Checked: PAW	Date: 1/4/15
Task: Sediment Basin #2	Sheet: 3	Of: 4

Determine Settling Velocity

Conversion Factor = 3.281 ft/sec per m/sec
 Gravitational Acceleration, g (m/s^2) = 9.81
 Specific Gravity of soil (s_s) = 2.6
 Kinematic Viscosity of water (ν) = 1.14E-06 m^2 / sec @ 20°C Ref 2, IV-11
 Diameter of the Design Particle d_{15} = 40.00E-06 m

Design Particle Settling Velocity = $(g / 18) * [(s_s - 1) / \nu] d^2 = 4.02E-03$ ft/sec

Route the Storm through the Basin using the Hydrograph Model

Set Height of Emergency Spillway at (ft) = 6.00 *See Hydrograph*
 Set Top of Dam at (ft) = 7.00

Emergency Spillway

Q_E (cfs) = 100-Yr Storm
 Q_E (cfs) = 0.0
 Cross Section = Trapezoid
 Channel Side Slope (z) = 5 (enter X for X:1)
 n = 0.03 Grass Lined
 V_p (ft/sec) = 5.0 Permissible Velocity for lining Ref 2, II-7
 Allowable Shear Stress (psf) = 2.0 Allowable Shear Stress for lining
 Bottom Width, b (ft) = 15

Calculate Required Depth of Spillway:

Normal-Depth Procedure

$AR^{2/3} = Qn / 1.49s^{0.5}$ $Q = VA$
 $Z_{req} = Qn / 1.49s^{0.5}$ Area (A) = $bd + z(d^2)$
 $Z_{av} = AR^{2/3}$ $R = Area / (b + 2d((z^2 + 1)^{.5}))$
 Avg Shear Stress (T) = $K_b * d * s$ * unit weight of water

Channel Slope ft/ft	Depth, d (ft)	A (sf)	Z_{req}	R	Z_{avail}	V (ft/sec)	T (psf)
0.01	0.00	0.00	0.00	0.00	0.00	0.0	0.0
0.02	0.00	0.00	0.00	0.00	0.00	0.0	0.0

Construct the channel to be : 15 ft, Bottom Width (measured at top of lining)
 1.0 ft, depth (measured at top of lining)
 1% slope

Anti-Seep Collar:

Anti-Seep Collar Size = 2 * Barrel Dia
 Anti-Seep Collar Size (ft) = 4
 Use Anti-Seep Collar Size (ft) = 4 x 4

Project: Charah Colon Mine	Computed: EAW	Date: 1/4/15
Subject: Permit Application	Checked: PAW	Date: 1/4/15
Task: Sediment Basin #2	Sheet: 4	Of: 4

Minimum Concrete Base for Riser:

Diameter of Riser (in) = 60 From Hydrograph
 Avg Density of Concrete (lbs/cf) = 87.6
 Density of Water (lbs/cf) = 62.4
 Riser Displacement (cf) = 102.10 $\text{Pi} * (\text{D}_R/24)^2 * \text{Total Ht of Riser}$
 Convert cf to cy = 27^{-1}
 Min Concrete Needed (cy) = 2.69
 Width & Length (ft) = 6
 Thickness (ft) = 2.0

Anti-Vortex Device:

Diameter of Riser (in) = 60 From Hydrograph
 Cylinder Diameter (in) = 90 Ref 3, III-104, Table 3.14-D
 Cylinder Thickness (gage) = 14
 Cylinder Height (in) = 29

Determine Tailwater conditions to size outlet apron

Use Normal Depth Procedure (Manning's Eqn.) Ref 2, II-7

$A * R^{2/3} = Q * n / 1.49 s^{0.5}$ Area (A) = $bd + z(d^2)$ $Z_{av} = A * R^{2/3}$
 $Z_{req} = Q * n / 1.49 s^{0.5}$ $R = \text{Area} / (b + 2d((z^2 + 1)^{0.5}))$

n = 0.069 6-inch diameter Rip Rap, Lined Channel
 Vp (ft/sec) = 9 Permissible Velocity for lining
 Side Slope (z) = 5 enter X for X:1
 s (ft/ft) = 0.02 Outlet Slope (estimated)
 Bottom Width (ft) = 12 6 * Barrel Diameter
 Q_B (cfs) = 3.8 Peak Flow out of the barrel 25-yr Hydrograph

Q (cfs)	Z _{req}	Flow Depth d (ft)	A (sf)	R (ft)	Z _{av}	V (ft/sec)
3.8	1.24	0.25	3.3	0.23	1.24	1.1

Flow Depth = Tailwater, d (ft) = 0.25 0.5 * Barrel Diameter (ft) = 1.00 Ref 1, 8.06.3
 Minimum Tailwater Conditions: $d < 0.5 * \text{Diameter of Outlet Pipe}$
 Maximum Tailwater Conditions: $d > 0.5 * \text{Diameter of Outlet Pipe}$

Since the Tailwater is less than half of the diameter of the outlet, use Minimum Tailwater conditions.

Barrel Diameter (ft)	Entrance (ft)	Length (ft)	Outlet Width (ft)	Median Rip Rap Size d ₅₀	Selected Rip Rap Size (in)
2	6	10	12	0.3	Class A

Conclusion

The basin can contain the 10-yr storm and pass the 100-yr storm without overtopping the berm.

HDR Computation

Project:	Charah Colon Mine	Computed: PAW	Date: 12/31/14
Subject:	Permit Application	Checked: EAW	Date: 1/2/15
Task:	Riser Pipe Perforations/Skimmer Flow	Sheet 1	Of 2

Diameter of Riser (in) = 60
 Circumference of Riser (in) = 188.5
 Height of Riser from bottom of barrel (in) = 62 From Hydrograph
 Vertical spacing between holes (in) = 0 center to center
 Water Stage increment (ft) 0.05

Orifice Equation

$Q = C_d * A * (2 * g * h)^{0.5}$ Ref 1, p III-11
 Q = cfs, discharge
 $C_d = 0.6$ coefficient of discharge
 A = sf, cross sectional area
 $g = 32.2$ ft/sec², gravity
 h = ft, driving head measured from the center of the pipe

Row	Perforations					Skimmer	# of skimmers
	1	2	3	4	5	2	
Holes per row	0	0	0	0	0		
Hole Diameter (in)	0.75	0.75	0.75	0.75	0.75		
Spacing edge to edge (in)							
Inlet Area (sf)	0.000	0.000	0.000	0.000	0.000		
Hole Stage (in)	0.50	0.50	0.50	0.50	0.50		
Hole Stage (ft)	0.04	0.04	0.04	0.04	0.04		

Water Stage (ft)	Flow (cfs)	Flow (cfs)	Flow (cfs)	Flow (cfs)	Flow (cfs)	Flow (cfs)	Total Flow (cfs)
0.00	0.00	0.00	0.00			0.00	0.00
0.04	0.00	0.00	0.00			0.00	0.00
0.09	0.00	0.00	0.00			0.00	0.00
0.14	0.00	0.00	0.00			0.00	0.00
0.19	0.00	0.00	0.00			0.00	0.00
0.24	0.00	0.00	0.00			0.00	0.00
0.29	0.00	0.00	0.00			0.00	0.00
0.34	0.00	0.00	0.00			0.30	0.30
0.39	0.00	0.00	0.00			0.30	0.30
0.44	0.00	0.00	0.00			0.30	0.30
0.49	0.00	0.00	0.00			0.30	0.30
0.54	0.00	0.00	0.00			0.30	0.30
0.59	0.00	0.00	0.00			0.30	0.30
0.64	0.00	0.00	0.00			0.30	0.30
0.69	0.00	0.00	0.00			0.30	0.30
0.74	0.00	0.00	0.00			0.30	0.30
0.79	0.00	0.00	0.00			0.30	0.30
0.84	0.00	0.00	0.00			0.30	0.30
0.89	0.00	0.00	0.00			0.30	0.30
0.94	0.00	0.00	0.00			0.30	0.30
0.99	0.00	0.00	0.00			0.30	0.30
1.04	0.00	0.00	0.00			0.30	0.30
1.09	0.00	0.00	0.00			0.30	0.30
1.14	0.00	0.00	0.00			0.30	0.30
1.19	0.00	0.00	0.00			0.30	0.30
1.24	0.00	0.00	0.00			0.30	0.30
1.29	0.00	0.00	0.00			0.30	0.30
1.34	0.00	0.00	0.00			0.30	0.30
1.39	0.00	0.00	0.00			0.30	0.30
1.44	0.00	0.00	0.00			0.30	0.30
1.49	0.00	0.00	0.00			0.30	0.30
1.54	0.00	0.00	0.00			0.30	0.30
1.59	0.00	0.00	0.00			0.30	0.30

HDR Computation

Project:	Charah Colon Mine	Computed: PAW	Date: 12/31/14
Subject:	Permit Application	Checked: EAW	Date: 1/2/15
Task:	Riser Pipe Perforations/Skimmer Flow	Sheet 2	Of 2

1.64	0.00	0.00	0.00	0.30	0.30
1.69	0.00	0.00	0.00	0.30	0.30
1.74	0.00	0.00	0.00	0.30	0.30
1.79	0.00	0.00	0.00	0.30	0.30
1.84	0.00	0.00	0.00	0.30	0.30
1.89	0.00	0.00	0.00	0.30	0.30
1.94	0.00	0.00	0.00	0.30	0.30
1.99	0.00	0.00	0.00	0.30	0.30
2.04	0.00	0.00	0.00	0.30	0.30
2.09	0.00	0.00	0.00	0.30	0.30
2.14	0.00	0.00	0.00	0.30	0.30
2.19	0.00	0.00	0.00	0.30	0.30
2.24	0.00	0.00	0.00	0.30	0.30
2.29	0.00	0.00	0.00	0.30	0.30
2.34	0.00	0.00	0.00	0.30	0.30
2.39	0.00	0.00	0.00	0.30	0.30
2.44	0.00	0.00	0.00	0.30	0.30
2.49	0.00	0.00	0.00	0.30	0.30
2.54	0.00	0.00	0.00	0.30	0.30
2.59	0.00	0.00	0.00	0.30	0.30
2.64	0.00	0.00	0.00	0.30	0.30
2.69	0.00	0.00	0.00	0.30	0.30
2.74	0.00	0.00	0.00	0.30	0.30
2.79	0.00	0.00	0.00	0.30	0.30
2.84	0.00	0.00	0.00	0.30	0.30
2.89	0.00	0.00	0.00	0.30	0.30
2.94	0.00	0.00	0.00	0.30	0.30
2.99	0.00	0.00	0.00	0.30	0.30
3.04	0.00	0.00	0.00	0.30	0.30
3.09	0.00	0.00	0.00	0.30	0.30
3.14	0.00	0.00	0.00	0.30	0.30
3.19	0.00	0.00	0.00	0.30	0.30
3.24	0.00	0.00	0.00	0.30	0.30
3.29	0.00	0.00	0.00	0.30	0.30
3.34	0.00	0.00	0.00	0.30	0.30
3.39	0.00	0.00	0.00	0.30	0.30
3.44	0.00	0.00	0.00	0.30	0.30
3.49	0.00	0.00	0.00	0.30	0.30
3.54	0.00	0.00	0.00	0.30	0.30
3.59	0.00	0.00	0.00	0.30	0.30
3.64	0.00	0.00	0.00	0.30	0.30
3.69	0.00	0.00	0.00	0.30	0.30
3.74	0.00	0.00	0.00	0.30	0.30
3.79	0.00	0.00	0.00	0.30	0.30
3.84	0.00	0.00	0.00	0.30	0.30
3.89	0.00	0.00	0.00	0.30	0.30
3.94	0.00	0.00	0.00	0.30	0.30
3.99	0.00	0.00	0.00	0.30	0.30

Qp = 101.32 cfs
 Tp = 28.19 minutes
 dT = Max of 2 minutes
 or 1.0% of increment to peak

Sediment Basin # 2 Colon

Phase 1
10 - year Storm Event

b = 1.2
 K_s = 35,760

Number of Riser/Barrel Assemblies = 2
 Diameter of Barrel = 24 (in)
 Height of Riser above barrel = 3.2 (ft)
 Height of Riser from bottom of barrel = 5.2 (ft) elevation 264.20
 Emergency Spillway = 6.0 (ft) elevation 265.00
 Total Height of Dam = 7.0 (ft) elevation 266.00
 Length of Emergency Spillway = 15 (ft)
 Diameter of Riser = 60 (in)
 Permanent Pond Stage = 0 (ft) elevation 259.0

4.0E-03 Settling Velocity of design particle (fps)
 2 Effective number of cells (2 is construction site #)
 100% Minimum Settling Efficiency
 5.1 ft Maximum Stage 264.06 msl elevation
 0.6 cfs Peak outflow
 0.6 cfs Peak Riser/Barrel outflow
 0.0 cfs Peak Weir flow

Notes:

1. Length of emergency spillway is the bottom width of the emergency spillway.
2. Settling efficiency neglects permanent pond volume

TIME (min)	INFLOW [cfs]	STORAGE [cu ft]	STAGE [ft]	Skimmer Flow [cfs]	RISER CAPACIT Y [cfs]	WEIR FLOW [cfs]	BARREL CAPACITY [cfs]	TOTAL OUTFLOW [cfs]	Bound Discharge [cfs]	Estimated Surface Area (sf)	Settling Efficiency [%]
0	0.0	0	0.0	0.00	0.00	0.00	0.00	0.00	0.00	-	N/A
2	1.3	0	0.0	0.00	0.00	0.00	0.00	0.00	0.00	-	N/A
4	4.9	150	0.0	0.00	0.00	0.00	0.00	0.00	43.22	19,647	N/A
6	10.9	744	0.0	0.00	0.00	0.00	0.00	0.00	53.74	24,429	N/A
8	18.8	2,053	0.1	0.00	0.00	0.00	0.00	0.00	61.71	28,050	N/A
10	28.3	4,312	0.2	0.00	0.00	0.00	0.00	0.00	68.28	31,035	N/A
12	38.9	7,712	0.3	0.00	0.00	0.00	0.00	0.00	73.90	33,592	N/A
14	50.1	12,383	0.4	0.30	0.30	0.00	0.30	0.59	78.83	35,830	100%
16	61.3	18,326	0.6	0.30	0.30	0.00	0.30	0.59	83.15	37,796	100%
18	72.0	25,613	0.7	0.30	0.30	0.00	0.30	0.59	87.03	39,559	100%
20	81.6	34,183	1.0	0.30	0.30	0.00	0.30	0.59	90.52	41,145	100%
22	89.7	43,907	1.2	0.30	0.30	0.00	0.30	0.59	93.66	42,573	100%
24	95.9	54,603	1.4	0.30	0.30	0.00	0.30	0.59	96.48	43,856	100%
26	99.8	66,039	1.7	0.30	0.30	0.00	0.30	0.59	99.02	45,007	100%
28	101.3	77,946	2.0	0.30	0.30	0.00	0.30	0.59	101.28	46,035	100%
30	100.3	90,032	2.2	0.30	0.30	0.00	0.30	0.59	103.28	46,948	100%
32	96.8	101,997	2.5	0.30	0.30	0.00	0.30	0.59	105.06	47,752	100%
34	91.1	113,546	2.7	0.30	0.30	0.00	0.30	0.59	106.60	48,455	100%
36	83.6	124,405	2.9	0.30	0.30	0.00	0.30	0.59	107.94	49,062	100%
38	76.3	134,368	3.1	0.30	0.30	0.00	0.30	0.59	109.08	49,580	100%
40	69.5	143,448	3.3	0.30	0.30	0.00	0.30	0.59	110.05	50,023	100%
42	63.4	151,721	3.5	0.30	0.30	0.00	0.30	0.59	110.89	50,407	100%
44	57.8	159,259	3.6	0.30	0.30	0.00	0.30	0.59	111.63	50,741	100%
46	52.7	166,127	3.8	0.30	0.30	0.00	0.30	0.59	112.27	51,033	100%
48	48.1	172,384	3.9	0.30	0.30	0.00	0.30	0.59	112.84	51,291	100%
50	43.8	178,083	4.0	0.30	0.30	0.00	0.30	0.59	113.34	51,519	100%
52	40.0	183,274	4.1	0.30	0.30	0.00	0.30	0.59	113.79	51,721	100%
54	36.5	188,001	4.2	0.30	0.30	0.00	0.30	0.59	114.18	51,901	100%
56	33.3	192,306	4.3	0.30	0.30	0.00	0.30	0.59	114.53	52,061	100%
58	30.3	196,225	4.4	0.30	0.30	0.00	0.30	0.59	114.85	52,204	100%
60	27.7	199,793	4.4	0.30	0.30	0.00	0.30	0.59	115.13	52,332	100%
62	25.2	203,040	4.5	0.30	0.30	0.00	0.30	0.59	115.38	52,448	100%
64	23.0	205,995	4.5	0.30	0.30	0.00	0.30	0.59	115.61	52,551	100%
66	21.0	208,684	4.6	0.30	0.30	0.00	0.30	0.59	115.82	52,644	100%
68	19.1	211,129	4.6	0.30	0.30	0.00	0.30	0.59	116.00	52,727	100%
70	17.4	213,353	4.7	0.30	0.30	0.00	0.30	0.59	116.17	52,803	100%
72	15.9	215,374	4.7	0.30	0.30	0.00	0.30	0.59	116.32	52,871	100%
74	14.5	217,211	4.8	0.30	0.30	0.00	0.30	0.59	116.45	52,932	100%
76	13.2	218,881	4.8	0.30	0.30	0.00	0.30	0.59	116.57	52,987	100%
78	12.1	220,396	4.8	0.30	0.30	0.00	0.30	0.59	116.68	53,037	100%
80	11.0	221,772	4.8	0.30	0.30	0.00	0.30	0.59	116.78	53,082	100%
82	10.0	223,021	4.9	0.30	0.30	0.00	0.30	0.59	116.87	53,122	100%

84	9.1	224,153	4.9	0.30	0.30	0.00	0.30	0.59	116.95	53,159	100%
86	8.3	225,180	4.9	0.30	0.30	0.00	0.30	0.59	117.02	53,192	100%
88	7.6	226,110	4.9	0.30	0.30	0.00	0.30	0.59	117.09	53,222	100%
90	6.9	226,951	4.9	0.30	0.30	0.00	0.30	0.59	117.15	53,249	100%
92	6.3	227,712	4.9	0.30	0.30	0.00	0.30	0.59	117.20	53,273	100%
94	5.8	228,400	5.0	0.30	0.30	0.00	0.30	0.59	117.25	53,295	100%
96	5.3	229,021	5.0	0.30	0.30	0.00	0.30	0.59	117.29	53,315	100%
98	4.8	229,581	5.0	0.30	0.30	0.00	0.30	0.59	117.33	53,333	100%
100	4.4	230,086	5.0	0.30	0.30	0.00	0.30	0.59	117.37	53,349	100%
102	4.0	230,540	5.0	0.30	0.30	0.00	0.30	0.59	117.40	53,363	100%
104	3.6	230,947	5.0	0.30	0.30	0.00	0.30	0.59	117.43	53,376	100%
106	3.3	231,313	5.0	0.30	0.30	0.00	0.30	0.59	117.45	53,387	100%
108	3.0	231,640	5.0	0.30	0.30	0.00	0.30	0.59	117.47	53,398	100%
110	2.8	231,932	5.0	0.30	0.30	0.00	0.30	0.59	117.49	53,407	100%
112	2.5	232,192	5.0	0.30	0.30	0.00	0.30	0.59	117.51	53,415	100%
114	2.3	232,422	5.0	0.30	0.30	0.00	0.30	0.59	117.53	53,422	100%
116	2.1	232,627	5.0	0.30	0.30	0.00	0.30	0.59	117.54	53,428	100%
118	1.9	232,807	5.0	0.30	0.30	0.00	0.30	0.59	117.55	53,434	100%
120	1.7	232,965	5.0	0.30	0.30	0.00	0.30	0.59	117.57	53,439	100%
122	1.6	233,102	5.0	0.30	0.30	0.00	0.30	0.59	117.58	53,443	100%
124	1.4	233,222	5.1	0.30	0.30	0.00	0.30	0.59	117.58	53,447	100%
126	1.3	233,325	5.1	0.30	0.30	0.00	0.30	0.59	117.59	53,450	100%
128	1.2	233,412	5.1	0.30	0.30	0.00	0.30	0.59	117.60	53,453	100%
130	1.1	233,485	5.1	0.30	0.30	0.00	0.30	0.59	117.60	53,455	100%
132	1.0	233,546	5.1	0.30	0.30	0.00	0.30	0.59	117.61	53,457	100%
134	0.9	233,595	5.1	0.30	0.30	0.00	0.30	0.59	117.61	53,459	100%
136	0.8	233,634	5.1	0.30	0.30	0.00	0.30	0.59	117.61	53,460	100%
138	0.8	233,663	5.1	0.30	0.30	0.00	0.30	0.59	117.61	53,461	100%
140	0.7	233,683	5.1	0.30	0.30	0.00	0.30	0.59	117.62	53,461	100%
142	0.6	233,695	5.1	0.30	0.30	0.00	0.30	0.59	117.62	53,462	100%
144	0.6	233,700	5.1	0.30	0.30	0.00	0.30	0.59	117.62	53,462	100%
146	0.5	233,698	5.1	0.30	0.30	0.00	0.30	0.59	117.62	53,462	100%
148	0.5	233,690	5.1	0.30	0.30	0.00	0.30	0.59	117.62	53,462	100%
150	0.4	233,676	5.1	0.30	0.30	0.00	0.30	0.59	117.61	53,461	100%
152	0.4	233,658	5.1	0.30	0.30	0.00	0.30	0.59	117.61	53,461	100%
154	0.4	233,634	5.1	0.30	0.30	0.00	0.30	0.59	117.61	53,460	100%
156	0.3	233,607	5.1	0.30	0.30	0.00	0.30	0.59	117.61	53,459	100%
158	0.3	233,576	5.1	0.30	0.30	0.00	0.30	0.59	117.61	53,458	100%
160	0.3	233,541	5.1	0.30	0.30	0.00	0.30	0.59	117.61	53,457	100%
162	0.3	233,503	5.1	0.30	0.30	0.00	0.30	0.59	117.60	53,456	100%
164	0.2	233,463	5.1	0.30	0.30	0.00	0.30	0.59	117.60	53,455	100%
166	0.2	233,419	5.1	0.30	0.30	0.00	0.30	0.59	117.60	53,453	100%
168	0.2	233,373	5.1	0.30	0.30	0.00	0.30	0.59	117.59	53,452	100%
170	0.2	233,325	5.1	0.30	0.30	0.00	0.30	0.59	117.59	53,450	100%
172	0.2	233,275	5.1	0.30	0.30	0.00	0.30	0.59	117.59	53,449	100%
174	0.1	233,223	5.1	0.30	0.30	0.00	0.30	0.59	117.58	53,447	100%
176	0.1	233,170	5.1	0.30	0.30	0.00	0.30	0.59	117.58	53,445	100%
178	0.1	233,115	5.0	0.30	0.30	0.00	0.30	0.59	117.58	53,444	100%
180	0.1	233,058	5.0	0.30	0.30	0.00	0.30	0.59	117.57	53,442	100%
182	0.1	233,000	5.0	0.30	0.30	0.00	0.30	0.59	117.57	53,440	100%
184	0.1	232,941	5.0	0.30	0.30	0.00	0.30	0.59	117.56	53,438	100%
186	0.1	232,881	5.0	0.30	0.30	0.00	0.30	0.59	117.56	53,436	100%
188	0.1	232,821	5.0	0.30	0.30	0.00	0.30	0.59	117.56	53,435	100%
190	0.1	232,759	5.0	0.30	0.30	0.00	0.30	0.59	117.55	53,433	100%
192	0.1	232,696	5.0	0.30	0.30	0.00	0.30	0.59	117.55	53,431	100%
194	0.1	232,633	5.0	0.30	0.30	0.00	0.30	0.59	117.54	53,429	100%
196	0.1	232,569	5.0	0.30	0.30	0.00	0.30	0.59	117.54	53,427	100%
198	0.0	232,504	5.0	0.30	0.30	0.00	0.30	0.59	117.53	53,425	100%
200	0.0	232,439	5.0	0.30	0.30	0.00	0.30	0.59	117.53	53,423	100%
202	0.0	232,373	5.0	0.30	0.30	0.00	0.30	0.59	117.53	53,421	100%
204	0.0	232,307	5.0	0.30	0.30	0.00	0.30	0.59	117.52	53,418	100%
206	0.0	232,241	5.0	0.30	0.30	0.00	0.30	0.59	117.52	53,416	100%

**Sediment Basin #2 Colon Mine Phase 1 Hydrograph
10-Yr Storm**

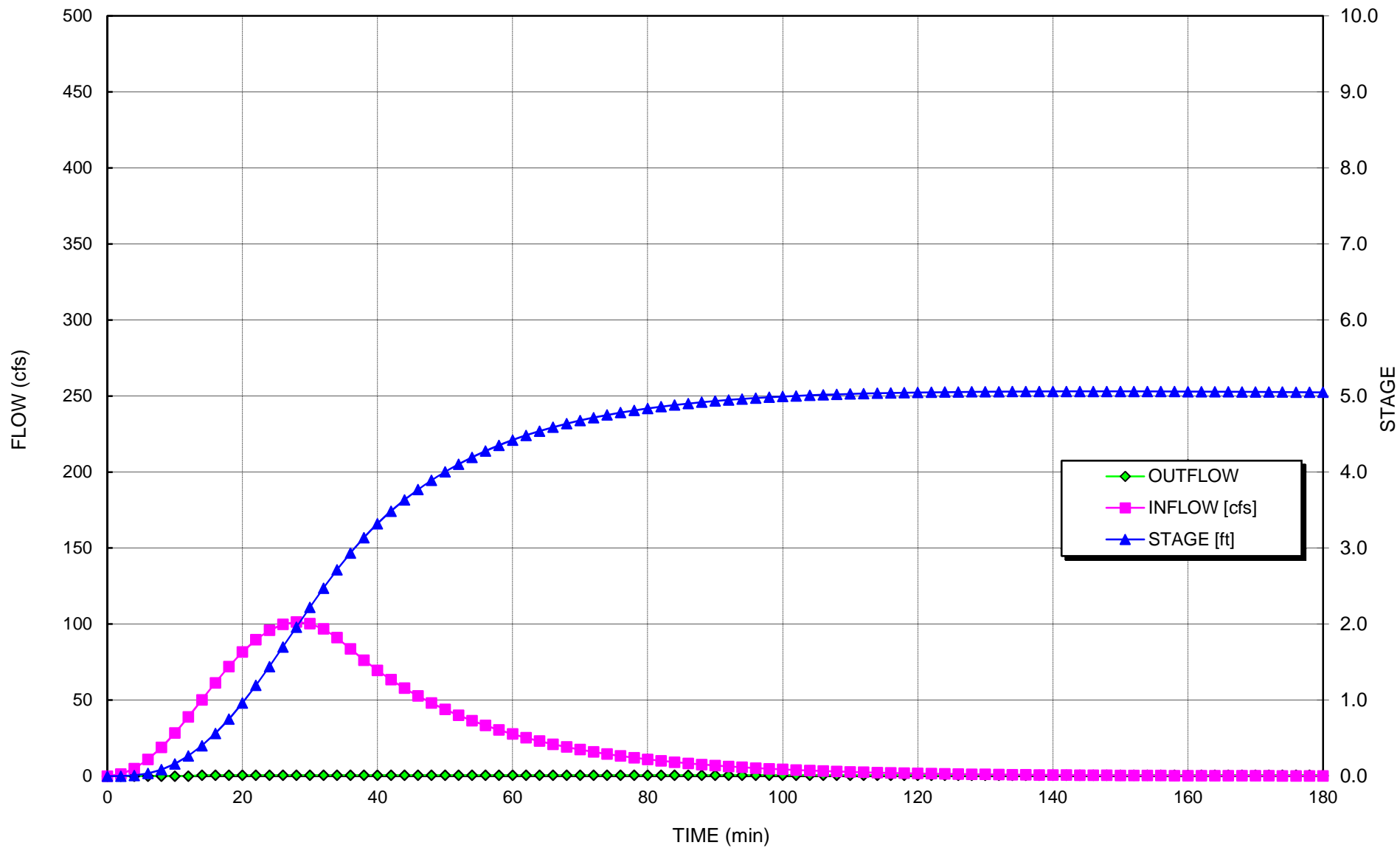

Qp = 79.90 cfs
 Tp = 30.89 minutes
 dT = Max of 2 minutes
 or 1.0% of increment to peak

Sediment Basin # 2 **Colon**
 Phase 2
10 - year Storm Event

Number of Riser/Barrel Assemblies = 2
 Diameter of Barrel = 24 (in)
 Height of Riser above barrel = 3.2 (ft)
 Height of Riser from bottom of barrel = 5.2 (ft) elevation 264.20
 Emergency Spillway = 6 (ft) elevation 265.00
 Total Height of Dam = 7 (ft) elevation 266.00
 Length of Emergency Spillway = 15 (ft)
 Diameter of Riser = 60 (in)
 Permanent Pond Stage = 0 (ft) elevation 259.0

b = 1.2
 Ks = 35,760

4.0E-03 Settling Velocity of design particle (fps)
 2 Effective number of cells (2 is construction site #)

100% Minimum Settling Efficiency	
4.4 ft Maximum Stage	263.44 msl elevation
0.6 cfs Peak outflow	
0.6 cfs Peak Riser/Barrel outflow	
0.0 cfs peak weir flow	

Notes:

1. Length of emergency spillway is the bottom width of the emergency spillway.
2. Settling efficiency neglects permanent pond volume

TIME (min)	INFLOW [cfs]	STORAGE [cu ft]	STAGE [ft]	Skimmer Flow [cfs]	RISER CAPACIT Y [cfs]	WEIR FLOW [cfs]	BARREL CAPACIT Y [cfs]	TOTAL OUTFLOW [cfs]	Bound Discharge [cfs]	Estimated Surface Area (sf)	Settling Efficiency [%]
0	0.0	0	0.0	0.00	0.00	0.00	0.00	0.00	0.00	-	N/A
2	0.8	0	0.0	0.00	0.00	0.00	0.00	0.00	0.00	-	N/A
4	3.3	99	0.0	0.00	0.00	0.00	0.00	0.00	40.82	18,555	N/A
6	7.2	490	0.0	0.00	0.00	0.00	0.00	0.00	50.77	23,077	N/A
8	12.5	1,355	0.1	0.00	0.00	0.00	0.00	0.00	58.32	26,507	N/A
10	18.9	2,856	0.1	0.00	0.00	0.00	0.00	0.00	64.55	29,341	N/A
12	26.2	5,129	0.2	0.00	0.00	0.00	0.00	0.00	69.91	31,776	N/A
14	34.1	8,277	0.3	0.00	0.00	0.00	0.00	0.00	74.62	33,917	N/A
16	42.2	12,368	0.4	0.30	0.30	0.00	0.30	0.59	78.81	35,825	100%
18	50.2	17,361	0.5	0.30	0.30	0.00	0.30	0.59	82.54	37,518	100%
20	57.8	23,316	0.7	0.30	0.30	0.00	0.30	0.59	85.92	39,056	100%
22	64.6	30,180	0.9	0.30	0.30	0.00	0.30	0.59	89.00	40,453	100%
24	70.5	37,867	1.1	0.30	0.30	0.00	0.30	0.59	91.79	41,723	100%
26	75.1	46,254	1.2	0.30	0.30	0.00	0.30	0.59	94.33	42,876	100%
28	78.2	55,190	1.5	0.30	0.30	0.00	0.30	0.59	96.62	43,920	100%
30	79.7	64,502	1.7	0.30	0.30	0.00	0.30	0.59	98.70	44,863	100%
32	79.6	73,999	1.9	0.30	0.30	0.00	0.30	0.59	100.56	45,710	100%
34	77.9	83,486	2.1	0.30	0.30	0.00	0.30	0.59	102.23	46,467	100%
36	74.6	92,765	2.3	0.30	0.30	0.00	0.30	0.59	103.71	47,139	100%
38	69.9	101,650	2.5	0.30	0.30	0.00	0.30	0.59	105.01	47,730	100%
40	64.4	109,968	2.6	0.30	0.30	0.00	0.30	0.59	106.14	48,245	100%
42	59.2	117,628	2.8	0.30	0.30	0.00	0.30	0.59	107.12	48,689	100%
44	54.4	124,663	2.9	0.30	0.30	0.00	0.30	0.59	107.97	49,076	100%
46	50.0	131,124	3.1	0.30	0.30	0.00	0.30	0.59	108.71	49,415	100%
48	46.0	137,059	3.2	0.30	0.30	0.00	0.30	0.59	109.37	49,714	100%
50	42.3	142,508	3.3	0.30	0.30	0.00	0.30	0.59	109.95	49,978	100%
52	38.9	147,512	3.4	0.30	0.30	0.00	0.30	0.59	110.47	50,214	100%
54	35.7	152,106	3.5	0.30	0.30	0.00	0.30	0.59	110.93	50,424	100%
56	32.9	156,324	3.6	0.30	0.30	0.00	0.30	0.59	111.35	50,612	100%
58	30.2	160,196	3.7	0.30	0.30	0.00	0.30	0.59	111.72	50,781	100%
60	27.8	163,749	3.7	0.30	0.30	0.00	0.30	0.59	112.05	50,933	100%
62	25.5	167,010	3.8	0.30	0.30	0.00	0.30	0.59	112.35	51,070	100%
64	23.5	170,002	3.8	0.30	0.30	0.00	0.30	0.59	112.63	51,194	100%
66	21.6	172,746	3.9	0.30	0.30	0.00	0.30	0.59	112.87	51,306	100%
68	19.8	175,264	3.9	0.30	0.30	0.00	0.30	0.59	113.10	51,407	100%
70	18.2	177,572	4.0	0.30	0.30	0.00	0.30	0.59	113.30	51,499	100%
72	16.8	179,689	4.0	0.30	0.30	0.00	0.30	0.59	113.48	51,582	100%
74	15.4	181,628	4.1	0.30	0.30	0.00	0.30	0.59	113.65	51,657	100%
76	14.2	183,406	4.1	0.30	0.30	0.00	0.30	0.59	113.80	51,726	100%
78	13.0	185,034	4.1	0.30	0.30	0.00	0.30	0.59	113.93	51,788	100%
80	12.0	186,525	4.2	0.30	0.30	0.00	0.30	0.59	114.06	51,845	100%
82	11.0	187,891	4.2	0.30	0.30	0.00	0.30	0.59	114.17	51,896	100%
84	10.1	189,140	4.2	0.30	0.30	0.00	0.30	0.59	114.28	51,943	100%

86	9.3	190,282	4.2	0.30	0.30	0.00	0.30	0.59	114.37	51,986	100%
88	8.5	191,327	4.3	0.30	0.30	0.00	0.30	0.59	114.45	52,025	100%
90	7.9	192,282	4.3	0.30	0.30	0.00	0.30	0.59	114.53	52,060	100%
92	7.2	193,154	4.3	0.30	0.30	0.00	0.30	0.59	114.60	52,092	100%
94	6.6	193,949	4.3	0.30	0.30	0.00	0.30	0.59	114.67	52,121	100%
96	6.1	194,675	4.3	0.30	0.30	0.00	0.30	0.59	114.73	52,148	100%
98	5.6	195,337	4.3	0.30	0.30	0.00	0.30	0.59	114.78	52,172	100%
100	5.2	195,939	4.3	0.30	0.30	0.00	0.30	0.59	114.83	52,194	100%
102	4.7	196,487	4.4	0.30	0.30	0.00	0.30	0.59	114.87	52,214	100%
104	4.4	196,985	4.4	0.30	0.30	0.00	0.30	0.59	114.91	52,232	100%
106	4.0	197,437	4.4	0.30	0.30	0.00	0.30	0.59	114.95	52,248	100%
108	3.7	197,847	4.4	0.30	0.30	0.00	0.30	0.59	114.98	52,263	100%
110	3.4	198,218	4.4	0.30	0.30	0.00	0.30	0.59	115.01	52,276	100%
112	3.1	198,554	4.4	0.30	0.30	0.00	0.30	0.59	115.03	52,288	100%
114	2.9	198,856	4.4	0.30	0.30	0.00	0.30	0.59	115.06	52,299	100%
116	2.6	199,129	4.4	0.30	0.30	0.00	0.30	0.59	115.08	52,309	100%
118	2.4	199,374	4.4	0.30	0.30	0.00	0.30	0.59	115.10	52,318	100%
120	2.2	199,593	4.4	0.30	0.30	0.00	0.30	0.59	115.12	52,325	100%
122	2.0	199,789	4.4	0.30	0.30	0.00	0.30	0.59	115.13	52,332	100%
124	1.9	199,963	4.4	0.30	0.30	0.00	0.30	0.59	115.14	52,339	100%
126	1.7	200,118	4.4	0.30	0.30	0.00	0.30	0.59	115.16	52,344	100%
128	1.6	200,254	4.4	0.30	0.30	0.00	0.30	0.59	115.17	52,349	100%
130	1.5	200,374	4.4	0.30	0.30	0.00	0.30	0.59	115.18	52,353	100%
132	1.3	200,478	4.4	0.30	0.30	0.00	0.30	0.59	115.19	52,357	100%
134	1.2	200,568	4.4	0.30	0.30	0.00	0.30	0.59	115.19	52,360	100%
136	1.1	200,645	4.4	0.30	0.30	0.00	0.30	0.59	115.20	52,363	100%
138	1.0	200,710	4.4	0.30	0.30	0.00	0.30	0.59	115.20	52,365	100%
140	1.0	200,764	4.4	0.30	0.30	0.00	0.30	0.59	115.21	52,367	100%
142	0.9	200,809	4.4	0.30	0.30	0.00	0.30	0.59	115.21	52,369	100%
144	0.8	200,843	4.4	0.30	0.30	0.00	0.30	0.59	115.21	52,370	100%
146	0.7	200,870	4.4	0.30	0.30	0.00	0.30	0.59	115.22	52,371	100%
148	0.7	200,888	4.4	0.30	0.30	0.00	0.30	0.59	115.22	52,371	100%
150	0.6	200,899	4.4	0.30	0.30	0.00	0.30	0.59	115.22	52,372	100%
152	0.6	200,904	4.4	0.30	0.30	0.00	0.30	0.59	115.22	52,372	100%
154	0.5	200,902	4.4	0.30	0.30	0.00	0.30	0.59	115.22	52,372	100%
156	0.5	200,895	4.4	0.30	0.30	0.00	0.30	0.59	115.22	52,372	100%
158	0.4	200,883	4.4	0.30	0.30	0.00	0.30	0.59	115.22	52,371	100%
160	0.4	200,866	4.4	0.30	0.30	0.00	0.30	0.59	115.22	52,371	100%
162	0.4	200,845	4.4	0.30	0.30	0.00	0.30	0.59	115.21	52,370	100%
164	0.3	200,820	4.4	0.30	0.30	0.00	0.30	0.59	115.21	52,369	100%
166	0.3	200,791	4.4	0.30	0.30	0.00	0.30	0.59	115.21	52,368	100%
168	0.3	200,758	4.4	0.30	0.30	0.00	0.30	0.59	115.21	52,367	100%
170	0.3	200,723	4.4	0.30	0.30	0.00	0.30	0.59	115.20	52,366	100%
172	0.2	200,684	4.4	0.30	0.30	0.00	0.30	0.59	115.20	52,364	100%
174	0.2	200,643	4.4	0.30	0.30	0.00	0.30	0.59	115.20	52,363	100%
176	0.2	200,600	4.4	0.30	0.30	0.00	0.30	0.59	115.19	52,361	100%
178	0.2	200,554	4.4	0.30	0.30	0.00	0.30	0.59	115.19	52,360	100%
180	0.2	200,507	4.4	0.30	0.30	0.00	0.30	0.59	115.19	52,358	100%
182	0.2	200,457	4.4	0.30	0.30	0.00	0.30	0.59	115.18	52,356	100%
184	0.2	200,406	4.4	0.30	0.30	0.00	0.30	0.59	115.18	52,354	100%
186	0.1	200,353	4.4	0.30	0.30	0.00	0.30	0.59	115.18	52,352	100%
188	0.1	200,299	4.4	0.30	0.30	0.00	0.30	0.59	115.17	52,351	100%
190	0.1	200,243	4.4	0.30	0.30	0.00	0.30	0.59	115.17	52,349	100%
192	0.1	200,186	4.4	0.30	0.30	0.00	0.30	0.59	115.16	52,347	100%
194	0.1	200,128	4.4	0.30	0.30	0.00	0.30	0.59	115.16	52,344	100%
196	0.1	200,069	4.4	0.30	0.30	0.00	0.30	0.59	115.15	52,342	100%
198	0.1	200,009	4.4	0.30	0.30	0.00	0.30	0.59	115.15	52,340	100%
200	0.1	199,949	4.4	0.30	0.30	0.00	0.30	0.59	115.14	52,338	100%
202	0.1	199,887	4.4	0.30	0.30	0.00	0.30	0.59	115.14	52,336	100%
204	0.1	199,824	4.4	0.30	0.30	0.00	0.30	0.59	115.13	52,334	100%

Sediment Basin #2 Colon Mine Phase 2 Hydrograph 10-Yr Storm

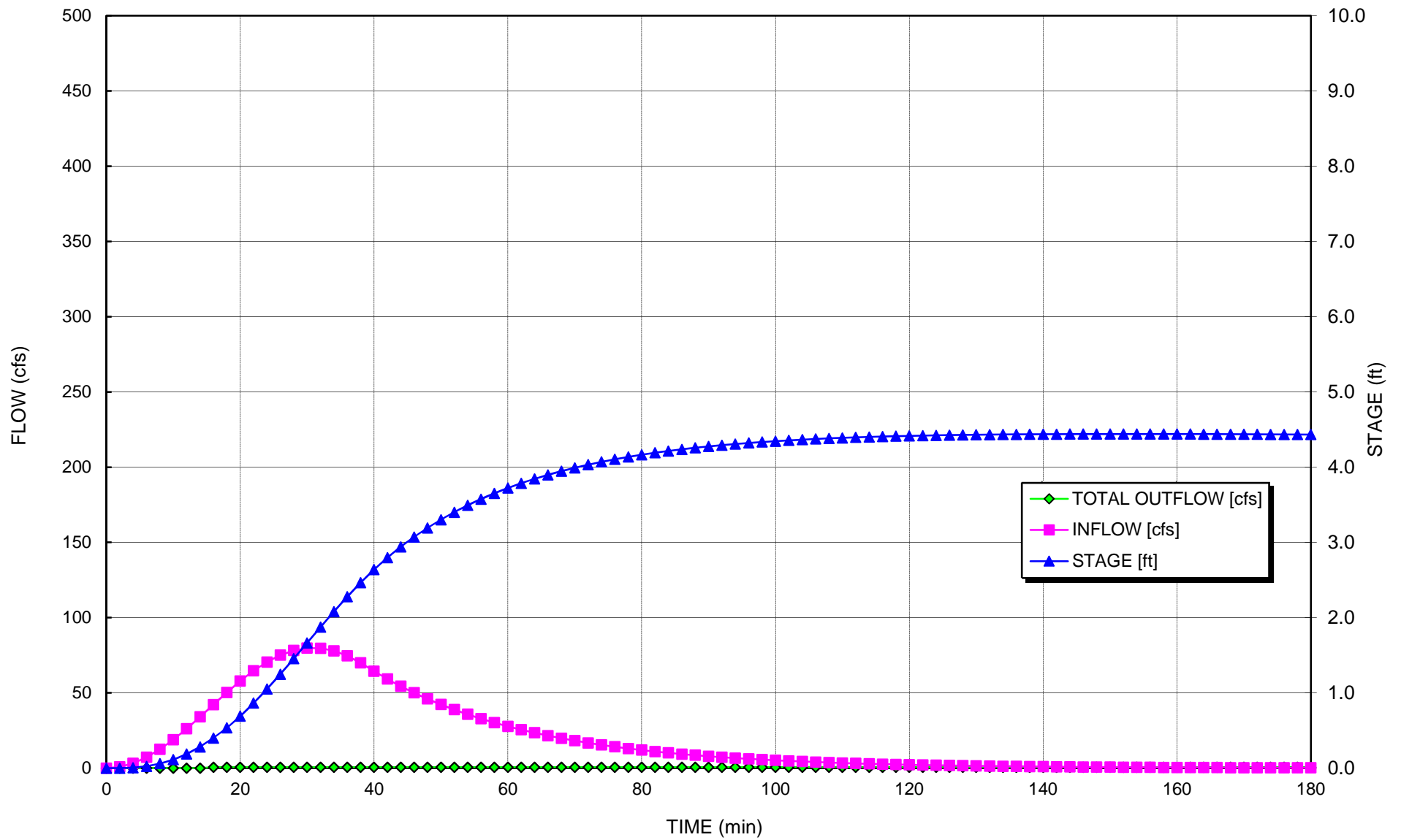

Qp = 98.71 cfs
 Tp = 31.23 minutes
 dT = Max of 2 minutes
 or 1.0% of increment to peak

Sediment Basin # 2 Colon
 Phase 2
25 - year Storm Event

Number of Riser/Barrel Assemblies = 2
 Diameter of Barrel = 24 (in)
 Height of Riser above barrel = 3.2 (ft)
 Height of Riser from bottom of barrel = 5.2 (ft) elevatior 264.20
 Emergency Spillway = 6.0 (ft) elevatior 265.00
 Total Height of Dam = 7.0 (ft) elevatior 266.00
 Length of Emergency Spillway = 15 (ft)
 Diameter of Riser = 60 (in)
 Permanent Pond Stage = 0 (ft) elevatior 259.0

b = 1.2
 Ks = 35,760

4.0E-03 Settling Velocity of design particle (fps)
 2 Effective number of cells (2 is construction site #)

100% Minimum Settling Efficiency	
5.3 ft Maximum Stage	264.3 msl elevation
3.8 cfs Peak outflow	
3.8 cfs Peak Riser/Barrel outflow	
0.0 cfs peak weir flow	

Notes:

1. Length of emergency spillway is the bottom width of the emergency spillway.
2. Settling efficiency neglects permanent pond volume

TIME (min)	INFLOW [cfs]	STORAGE [cu ft]	STAGE [ft]	Skimmer Flow [cfs]	RISER CAPACIT Y [cfs]	WEIR FLOW [cfs]	BARREL CAPACITY [cfs]	TOTAL OUTFL OW [cfs]	Bound Discharge [cfs]	Estimated Surface Area (sf)	Settling Efficiency [%]
0	0.0	0	0.0	0.00	0.00	0.00	0.00	0.00	0.00	-	N/A
2	1.0	0	0.0	0.00	0.00	0.00	0.00	0.00	0.00	-	N/A
4	3.9	119	0.0	0.00	0.00	0.00	0.00	0.00	41.89	19,041	N/A
6	8.7	592	0.0	0.00	0.00	0.00	0.00	0.00	52.10	23,682	N/A
8	15.1	1,639	0.1	0.00	0.00	0.00	0.00	0.00	59.85	27,203	N/A
10	22.9	3,455	0.1	0.00	0.00	0.00	0.00	0.00	66.25	30,112	N/A
12	31.8	6,208	0.2	0.00	0.00	0.00	0.00	0.00	71.75	32,614	N/A
14	41.4	10,024	0.3	0.00	0.00	0.00	0.00	0.00	76.59	34,813	N/A
16	51.3	14,988	0.5	0.30	0.30	0.00	0.30	0.59	80.90	36,775	100%
18	61.1	21,069	0.6	0.30	0.30	0.00	0.30	0.59	84.75	38,521	100%
20	70.4	28,328	0.8	0.30	0.30	0.00	0.30	0.59	88.23	40,106	100%
22	78.9	36,708	1.0	0.30	0.30	0.00	0.30	0.59	91.40	41,547	100%
24	86.2	46,108	1.2	0.30	0.30	0.00	0.30	0.59	94.29	42,857	100%
26	92.0	56,384	1.5	0.30	0.30	0.00	0.30	0.59	96.91	44,048	100%
28	96.1	67,357	1.7	0.30	0.30	0.00	0.30	0.59	99.28	45,128	100%
30	98.3	78,821	2.0	0.30	0.30	0.00	0.30	0.59	101.43	46,105	100%
32	98.6	90,550	2.2	0.30	0.30	0.00	0.30	0.59	103.37	46,984	100%
34	96.8	102,307	2.5	0.30	0.30	0.00	0.30	0.59	105.10	47,772	100%
36	93.1	113,853	2.7	0.30	0.30	0.00	0.30	0.59	106.64	48,473	100%
38	87.7	124,958	2.9	0.30	0.30	0.00	0.30	0.59	108.00	49,092	100%
40	81.0	135,412	3.2	0.30	0.30	0.00	0.30	0.59	109.19	49,632	100%
42	74.6	145,066	3.4	0.30	0.30	0.00	0.30	0.59	110.22	50,100	100%
44	68.6	153,944	3.5	0.30	0.30	0.00	0.30	0.59	111.11	50,507	100%
46	63.1	162,107	3.7	0.30	0.30	0.00	0.30	0.59	111.90	50,863	100%
48	58.1	169,612	3.8	0.30	0.30	0.00	0.30	0.59	112.59	51,178	100%
50	53.5	176,512	4.0	0.30	0.30	0.00	0.30	0.59	113.20	51,457	100%
52	49.2	182,855	4.1	0.30	0.30	0.00	0.30	0.59	113.75	51,705	100%
54	45.3	188,686	4.2	0.30	0.30	0.00	0.30	0.59	114.24	51,926	100%
56	41.6	194,045	4.3	0.30	0.30	0.00	0.30	0.59	114.67	52,125	100%
58	38.3	198,971	4.4	0.30	0.30	0.00	0.30	0.59	115.07	52,303	100%
60	35.3	203,497	4.5	0.30	0.30	0.00	0.30	0.59	115.42	52,464	100%
62	32.4	207,656	4.6	0.30	0.30	0.00	0.30	0.59	115.74	52,608	100%
64	29.8	211,478	4.6	0.30	0.30	0.00	0.30	0.59	116.03	52,739	100%
66	27.5	214,988	4.7	0.30	0.30	0.00	0.30	0.59	116.29	52,858	100%
68	25.3	218,212	4.8	0.30	0.30	0.00	0.30	0.59	116.52	52,965	100%
70	23.2	221,173	4.8	0.30	0.30	0.00	0.30	0.59	116.74	53,062	100%
72	21.4	223,892	4.9	0.30	0.30	0.00	0.30	0.59	116.93	53,151	100%
74	19.7	226,388	4.9	0.30	0.30	0.00	0.30	0.59	117.11	53,231	100%
76	18.1	228,679	5.0	0.30	0.30	0.00	0.30	0.59	117.27	53,304	100%
78	16.7	230,782	5.0	0.30	0.30	0.00	0.30	0.59	117.42	53,371	100%
80	15.3	232,710	5.0	0.30	0.30	0.00	0.30	0.59	117.55	53,431	100%
82	14.1	234,479	5.1	0.30	0.30	0.00	0.30	0.59	117.67	53,486	100%
84	13.0	236,101	5.1	0.30	0.30	0.00	0.30	0.59	117.78	53,536	100%

86	11.9	237,588	5.1	0.30	0.30	0.00	0.30	0.59	117.88	53,582	100%
88	11.0	238,951	5.2	0.30	0.30	0.00	0.30	0.59	117.97	53,624	100%
90	10.1	240,199	5.2	0.30	0.30	0.00	0.30	0.59	118.06	53,662	100%
92	9.3	241,341	5.2	0.30	0.31	0.00	30.96	0.61	118.13	53,697	100%
94	8.6	242,384	5.2	0.30	0.47	0.00	31.04	0.95	118.20	53,728	100%
96	7.9	243,298	5.2	0.30	0.71	0.00	31.10	1.41	118.26	53,756	100%
98	7.2	244,074	5.3	0.30	0.95	0.00	31.15	1.90	118.31	53,779	100%
100	6.7	244,716	5.3	0.30	1.18	0.00	31.19	2.35	118.36	53,798	100%
102	6.1	245,234	5.3	0.30	1.38	0.00	31.23	2.75	118.39	53,814	100%
104	5.6	245,640	5.3	0.30	1.54	0.00	31.26	3.08	118.42	53,826	100%
106	5.2	245,948	5.3	0.30	1.67	0.00	31.28	3.34	118.44	53,835	100%
108	4.8	246,170	5.3	0.30	1.77	0.00	31.29	3.54	118.45	53,842	100%
110	4.4	246,319	5.3	0.30	1.83	0.00	31.30	3.67	118.46	53,846	100%
112	4.0	246,407	5.3	0.30	1.87	0.00	31.31	3.75	118.47	53,849	100%
114	3.7	246,443	5.3	0.30	1.89	0.00	31.31	3.78	118.47	53,850	100%
116	3.4	246,436	5.3	0.30	1.89	0.00	31.31	3.77	118.47	53,850	100%
118	3.2	246,394	5.3	0.30	1.87	0.00	31.31	3.74	118.47	53,849	100%
120	2.9	246,324	5.3	0.30	1.84	0.00	31.30	3.67	118.46	53,846	100%
122	2.7	246,231	5.3	0.30	1.80	0.00	31.30	3.59	118.46	53,844	100%
124	2.5	246,121	5.3	0.30	1.75	0.00	31.29	3.49	118.45	53,840	100%
126	2.3	245,996	5.3	0.30	1.69	0.00	31.28	3.38	118.44	53,837	100%
128	2.1	245,861	5.3	0.30	1.63	0.00	31.27	3.27	118.43	53,833	100%
130	1.9	245,719	5.3	0.30	1.57	0.00	31.26	3.15	118.42	53,828	100%
132	1.8	245,570	5.3	0.30	1.51	0.00	31.25	3.02	118.41	53,824	100%
134	1.6	245,419	5.3	0.30	1.45	0.00	31.24	2.90	118.40	53,819	100%
136	1.5	245,265	5.3	0.30	1.39	0.00	31.23	2.78	118.39	53,815	100%
138	1.4	245,111	5.3	0.30	1.33	0.00	31.22	2.65	118.38	53,810	100%
140	1.3	244,957	5.3	0.30	1.27	0.00	31.21	2.53	118.37	53,806	100%
142	1.2	244,804	5.3	0.30	1.21	0.00	31.20	2.42	118.36	53,801	100%
144	1.1	244,653	5.3	0.30	1.15	0.00	31.19	2.31	118.35	53,797	100%
146	1.0	244,505	5.3	0.30	1.10	0.00	31.18	2.20	118.34	53,792	100%
148	0.9	244,359	5.3	0.30	1.05	0.00	31.17	2.09	118.33	53,788	100%
150	0.8	244,216	5.3	0.30	1.00	0.00	31.16	1.99	118.32	53,783	100%
152	0.8	244,077	5.3	0.30	0.95	0.00	31.15	1.90	118.31	53,779	100%
154	0.7	243,941	5.3	0.30	0.90	0.00	31.14	1.81	118.31	53,775	100%
156	0.6	243,808	5.2	0.30	0.86	0.00	31.13	1.72	118.30	53,771	100%
158	0.6	243,679	5.2	0.30	0.82	0.00	31.12	1.64	118.29	53,767	100%
160	0.5	243,554	5.2	0.30	0.78	0.00	31.11	1.56	118.28	53,764	100%
162	0.5	243,432	5.2	0.30	0.75	0.00	31.11	1.49	118.27	53,760	100%
164	0.5	243,314	5.2	0.30	0.71	0.00	31.10	1.42	118.26	53,756	100%
166	0.4	243,199	5.2	0.30	0.68	0.00	31.09	1.36	118.26	53,753	100%
168	0.4	243,088	5.2	0.30	0.65	0.00	31.08	1.29	118.25	53,750	100%
170	0.4	242,980	5.2	0.30	0.62	0.00	31.08	1.24	118.24	53,746	100%
172	0.3	242,875	5.2	0.30	0.59	0.00	31.07	1.18	118.23	53,743	100%
174	0.3	242,773	5.2	0.30	0.56	0.00	31.06	1.13	118.23	53,740	100%
176	0.3	242,675	5.2	0.30	0.54	0.00	31.05	1.08	118.22	53,737	100%
178	0.3	242,579	5.2	0.30	0.52	0.00	31.05	1.03	118.22	53,734	100%
180	0.2	242,486	5.2	0.30	0.50	0.00	31.04	0.99	118.21	53,731	100%
182	0.2	242,396	5.2	0.30	0.48	0.00	31.04	0.95	118.20	53,729	100%
184	0.2	242,308	5.2	0.30	0.46	0.00	31.03	0.91	118.20	53,726	100%
186	0.2	242,222	5.2	0.30	0.44	0.00	31.02	0.88	118.19	53,723	100%
188	0.2	242,139	5.2	0.30	0.42	0.00	31.02	0.84	118.19	53,721	100%
190	0.2	242,059	5.2	0.30	0.41	0.00	31.01	0.81	118.18	53,719	100%
192	0.1	241,980	5.2	0.30	0.39	0.00	31.01	0.78	118.18	53,716	100%
194	0.1	241,903	5.2	0.30	0.38	0.00	31.00	0.76	118.17	53,714	100%
196	0.1	241,828	5.2	0.30	0.37	0.00	31.00	0.73	118.17	53,712	100%
198	0.1	241,755	5.2	0.30	0.36	0.00	30.99	0.71	118.16	53,709	100%
200	0.1	241,683	5.2	0.30	0.34	0.00	30.99	0.69	118.16	53,707	100%
202	0.1	241,613	5.2	0.30	0.33	0.00	30.98	0.67	118.15	53,705	100%
204	0.1	241,544	5.2	0.30	0.33	0.00	30.98	0.65	118.15	53,703	100%
206	0.1	241,476	5.2	0.30	0.32	0.00	30.97	0.64	118.14	53,701	100%

**Sediment Basin #2 Colon Mine Phase 2 Hydrograph
25-Yr Storm**

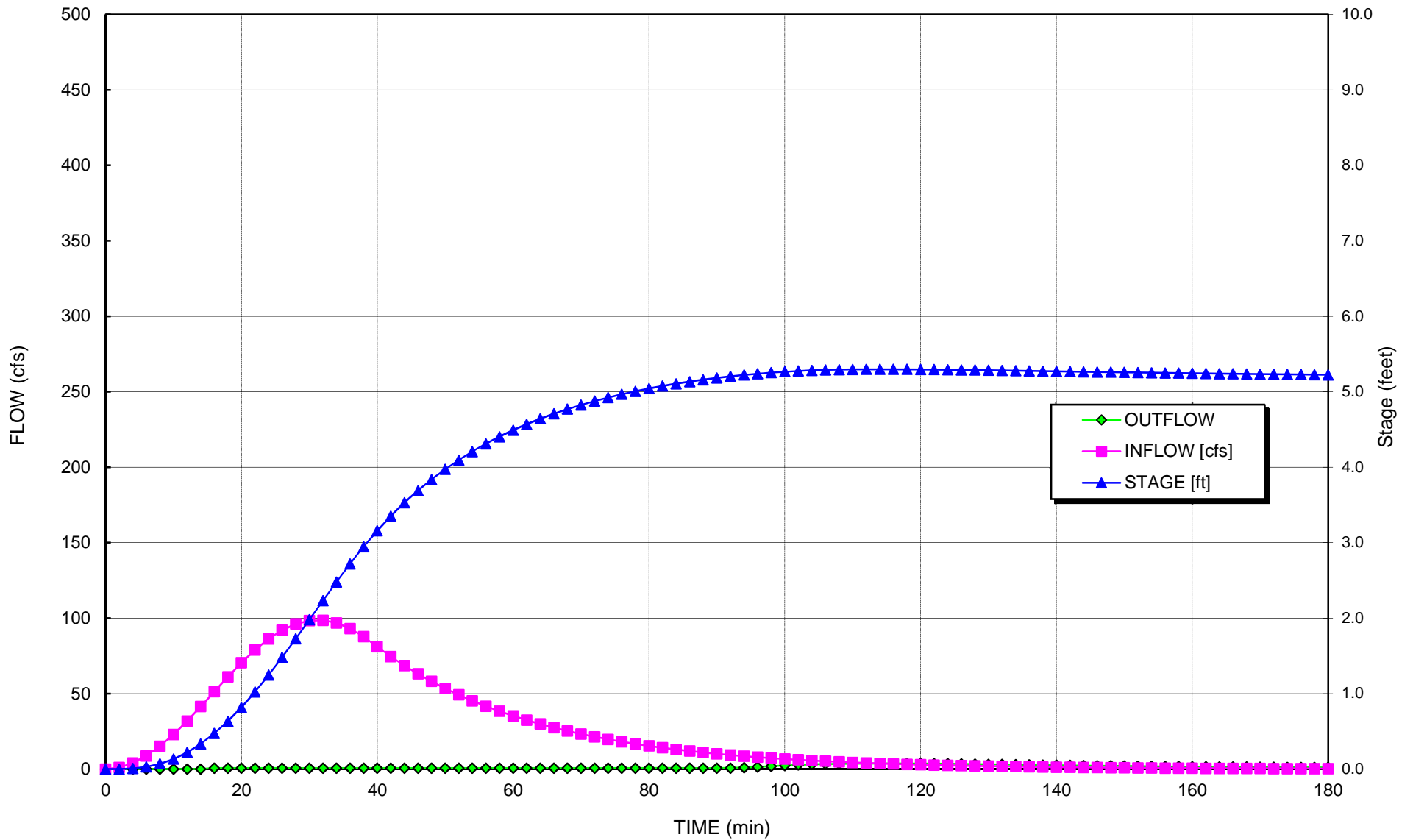

Sediment Basin # 2 Colon

Phase 2
100 - year Storm Event

Qp = 128.6 cfs
 Tp = 31.7 minutes
 dT = Max of 2 minutes
 or 1.0% of increment to peak

b = 1.2
 Ks = 35,760

Number of Riser/Barrel Assemblies = 2
 Diameter of Barrel = 24 (in)
 Height of Riser above barrel = 3.2 (ft)
 Height of Riser from bottom of barrel = 5.2 (ft) elevation 264.20
 Emergency Spillway = 6.0 (ft) elevation 265.00
 Total Height of Dam = 7.0 (ft) elevation 266.00
 Length of Emergency Spillway = 15 (ft)
 Diameter of Riser = 60 (in)
 Permanent Pond Stage = 0 (ft) elevation 259.0

4.0E-03 Settling Velocity of design particle (fps)
 2 Effective number of cells (2 is construction site #)

94% Minimum Settling Efficiency	
5.7 ft Maximum Stage	264.7 msl elevation
36.2 cfs Peak outflow	
36.2 cfs Peak Riser/Barrel outflow	
0.0 cfs peak weir flow	

Notes:

1. Length of emergency spillway is the bottom width of the emergency spillway.
2. Settling efficiency neglects permanent pond volume

TIME (min)	INFLOW [cfs]	STORAGE [cu ft]	STAGE [ft]	Skimmer Flow [cfs]	RISER CAPACIT Y [cfs]	WEIR FLOW [cfs]	BARREL CAPACITY [cfs]	TOTAL OUTFLOW [cfs]	Bound Discharge [cfs]	Estimated Surface Area (sf)	Settling Efficiency [%]
0	0.0	0	0.0	0.00	0.00	0.00	0.00	0.00	0.00	-	N/A
2	1.3	0	0.0	0.00	0.00	0.00	0.00	0.00	0.00	-	N/A
4	5.0	151	0.0	0.00	0.00	0.00	0.00	0.00	43.25	19,658	N/A
6	11.0	749	0.0	0.00	0.00	0.00	0.00	0.00	53.79	24,451	N/A
8	19.2	2,073	0.1	0.00	0.00	0.00	0.00	0.00	61.79	28,087	N/A
10	29.1	4,373	0.2	0.00	0.00	0.00	0.00	0.00	68.41	31,093	N/A
12	40.3	7,860	0.3	0.00	0.00	0.00	0.00	0.00	74.09	33,679	N/A
14	52.6	12,701	0.4	0.30	0.30	0.00	0.30	0.59	79.10	35,954	100%
16	65.2	18,937	0.6	0.30	0.30	0.00	0.30	0.59	83.52	37,965	100%
18	77.9	26,695	0.8	0.30	0.30	0.00	0.30	0.59	87.52	39,783	100%
20	90.0	35,969	1.0	0.30	0.30	0.00	0.30	0.59	91.15	41,432	100%
22	101.1	46,697	1.3	0.30	0.30	0.00	0.30	0.59	94.45	42,932	100%
24	110.8	58,757	1.5	0.30	0.30	0.00	0.30	0.59	97.45	44,296	100%
26	118.6	71,978	1.8	0.30	0.30	0.00	0.30	0.59	100.18	45,538	100%
28	124.3	86,141	2.1	0.30	0.30	0.00	0.30	0.59	102.67	46,666	100%
30	127.7	100,990	2.5	0.30	0.30	0.00	0.30	0.59	104.91	47,688	100%
32	128.6	116,245	2.8	0.30	0.30	0.00	0.30	0.59	106.94	48,611	100%
34	127.0	131,608	3.1	0.30	0.30	0.00	0.30	0.59	108.77	49,440	100%
36	122.9	146,777	3.4	0.30	0.30	0.00	0.30	0.59	110.40	50,180	100%
38	116.6	161,457	3.7	0.30	0.30	0.00	0.30	0.59	111.84	50,836	100%
40	108.3	175,373	3.9	0.30	0.30	0.00	0.30	0.59	113.10	51,411	100%
42	99.8	188,302	4.2	0.30	0.30	0.00	0.30	0.59	114.21	51,912	100%
44	91.9	200,207	4.4	0.30	0.30	0.00	0.30	0.59	115.16	52,347	100%
46	84.7	211,170	4.6	0.30	0.30	0.00	0.30	0.59	116.00	52,729	100%
48	78.0	221,264	4.8	0.30	0.30	0.00	0.30	0.59	116.74	53,065	100%
50	71.9	230,557	5.0	0.30	0.30	0.00	0.30	0.59	117.40	53,363	100%
52	66.2	239,114	5.2	0.30	0.30	0.00	0.30	0.59	117.98	53,629	100%
54	61.0	246,992	5.3	0.30	2.14	0.00	31.35	4.29	118.51	53,866	100%
56	56.2	253,800	5.4	0.30	6.18	0.00	31.80	12.37	118.95	54,066	99%
58	51.8	259,062	5.5	0.30	10.20	0.00	32.15	20.40	119.28	54,218	98%
60	47.7	262,830	5.6	0.30	13.47	0.00	32.40	26.93	119.51	54,324	96%
62	44.0	265,324	5.6	0.30	15.79	0.00	32.56	31.58	119.67	54,394	95%
64	40.5	266,810	5.7	0.30	17.23	0.00	32.65	34.46	119.76	54,436	94%
66	37.3	267,535	5.7	0.30	17.95	0.00	32.70	35.90	119.80	54,456	94%
68	34.4	267,705	5.7	0.30	18.12	0.00	32.71	36.24	119.81	54,461	94%
70	31.7	267,482	5.7	0.30	17.89	0.00	32.70	35.79	119.80	54,454	94%
72	29.2	266,988	5.7	0.30	17.40	0.00	32.66	34.81	119.77	54,441	94%
74	26.9	266,312	5.7	0.30	16.74	0.00	32.62	33.48	119.73	54,422	94%
76	24.8	265,519	5.7	0.30	15.98	0.00	32.57	31.95	119.68	54,400	95%
78	22.8	264,657	5.6	0.30	15.16	0.00	32.51	30.31	119.63	54,376	95%
80	21.0	263,757	5.6	0.30	14.32	0.00	32.46	28.63	119.57	54,350	96%
82	19.4	262,844	5.6	0.30	13.48	0.00	32.40	26.96	119.51	54,325	96%
84	17.8	261,933	5.6	0.30	12.66	0.00	32.34	25.32	119.46	54,299	96%

86	16.4	261,035	5.6	0.30	11.87	0.00	32.28	23.74	119.40	54,274	97%
88	15.1	260,158	5.6	0.30	11.12	0.00	32.22	22.24	119.35	54,249	97%
90	14.0	259,307	5.5	0.30	10.40	0.00	32.17	20.80	119.29	54,225	97%
92	12.9	258,485	5.5	0.30	9.73	0.00	32.11	19.45	119.24	54,201	98%
94	11.8	257,693	5.5	0.30	9.09	0.00	32.06	18.18	119.19	54,178	98%
96	10.9	256,932	5.5	0.30	8.49	0.00	32.01	16.98	119.14	54,157	98%
98	10.0	256,203	5.5	0.30	7.93	0.00	31.96	15.86	119.10	54,136	98%
100	9.3	255,505	5.5	0.30	7.41	0.00	31.92	14.82	119.05	54,116	99%
102	8.5	254,838	5.5	0.30	6.92	0.00	31.87	13.84	119.01	54,096	99%
104	7.9	254,201	5.4	0.30	6.46	0.00	31.83	12.93	118.97	54,078	99%
106	7.2	253,592	5.4	0.30	6.04	0.00	31.79	12.08	118.93	54,060	99%
108	6.7	253,012	5.4	0.30	5.64	0.00	31.75	11.29	118.90	54,043	99%
110	6.1	252,458	5.4	0.30	5.27	0.00	31.71	10.55	118.86	54,027	99%
112	5.7	251,930	5.4	0.30	4.93	0.00	31.68	9.86	118.83	54,012	99%
114	5.2	251,426	5.4	0.30	4.61	0.00	31.65	9.22	118.79	53,997	99%
116	4.8	250,946	5.4	0.30	4.31	0.00	31.61	8.62	118.76	53,983	99%
118	4.4	250,488	5.4	0.30	4.03	0.00	31.58	8.06	118.73	53,970	100%
120	4.1	250,052	5.4	0.30	3.77	0.00	31.55	7.55	118.70	53,957	100%
122	3.8	249,635	5.4	0.30	3.53	0.00	31.53	7.07	118.68	53,945	100%
124	3.5	249,238	5.4	0.30	3.31	0.00	31.50	6.62	118.65	53,933	100%
126	3.2	248,860	5.3	0.30	3.10	0.00	31.47	6.20	118.63	53,922	100%
128	2.9	248,499	5.3	0.30	2.90	0.00	31.45	5.81	118.60	53,911	100%
130	2.7	248,154	5.3	0.30	2.72	0.00	31.43	5.45	118.58	53,901	100%
132	2.5	247,825	5.3	0.30	2.55	0.00	31.40	5.11	118.56	53,891	100%
134	2.3	247,511	5.3	0.30	2.40	0.00	31.38	4.79	118.54	53,882	100%
136	2.1	247,212	5.3	0.30	2.25	0.00	31.36	4.50	118.52	53,873	100%
138	1.9	246,926	5.3	0.30	2.11	0.00	31.34	4.23	118.50	53,864	100%
140	1.8	246,652	5.3	0.30	1.99	0.00	31.33	3.97	118.48	53,856	100%
142	1.7	246,391	5.3	0.30	1.87	0.00	31.31	3.73	118.47	53,848	100%
144	1.5	246,142	5.3	0.30	1.76	0.00	31.29	3.51	118.45	53,841	100%
146	1.4	245,904	5.3	0.30	1.65	0.00	31.27	3.30	118.43	53,834	100%
148	1.3	245,676	5.3	0.30	1.56	0.00	31.26	3.11	118.42	53,827	100%
150	1.2	245,457	5.3	0.30	1.47	0.00	31.24	2.93	118.41	53,821	100%
152	1.1	245,249	5.3	0.30	1.38	0.00	31.23	2.76	118.39	53,814	100%
154	1.0	245,049	5.3	0.30	1.30	0.00	31.22	2.61	118.38	53,808	100%
156	0.9	244,858	5.3	0.30	1.23	0.00	31.20	2.46	118.37	53,803	100%
158	0.9	244,675	5.3	0.30	1.16	0.00	31.19	2.32	118.35	53,797	100%
160	0.8	244,499	5.3	0.30	1.10	0.00	31.18	2.19	118.34	53,792	100%
162	0.7	244,331	5.3	0.30	1.04	0.00	31.17	2.07	118.33	53,787	100%
164	0.7	244,169	5.3	0.30	0.98	0.00	31.16	1.96	118.32	53,782	100%
166	0.6	244,015	5.3	0.30	0.93	0.00	31.15	1.86	118.31	53,777	100%
168	0.6	243,866	5.3	0.30	0.88	0.00	31.14	1.76	118.30	53,773	100%
170	0.5	243,723	5.2	0.30	0.83	0.00	31.13	1.67	118.29	53,769	100%
172	0.5	243,586	5.2	0.30	0.79	0.00	31.12	1.58	118.28	53,765	100%
174	0.4	243,454	5.2	0.30	0.75	0.00	31.11	1.50	118.27	53,761	100%
176	0.4	243,327	5.2	0.30	0.71	0.00	31.10	1.43	118.26	53,757	100%
178	0.4	243,205	5.2	0.30	0.68	0.00	31.09	1.36	118.26	53,753	100%
180	0.3	243,087	5.2	0.30	0.65	0.00	31.08	1.29	118.25	53,750	100%
182	0.3	242,974	5.2	0.30	0.62	0.00	31.08	1.23	118.24	53,746	100%
184	0.3	242,865	5.2	0.30	0.59	0.00	31.07	1.17	118.23	53,743	100%
186	0.3	242,759	5.2	0.30	0.56	0.00	31.06	1.12	118.23	53,740	100%
188	0.3	242,657	5.2	0.30	0.54	0.00	31.05	1.07	118.22	53,737	100%
190	0.2	242,559	5.2	0.30	0.51	0.00	31.05	1.02	118.21	53,734	100%
192	0.2	242,464	5.2	0.30	0.49	0.00	31.04	0.98	118.21	53,731	100%
194	0.2	242,371	5.2	0.30	0.47	0.00	31.03	0.94	118.20	53,728	100%
196	0.2	242,282	5.2	0.30	0.45	0.00	31.03	0.90	118.20	53,725	100%
198	0.2	242,196	5.2	0.30	0.43	0.00	31.02	0.87	118.19	53,723	100%
200	0.2	242,112	5.2	0.30	0.42	0.00	31.02	0.83	118.18	53,720	100%
202	0.1	242,030	5.2	0.30	0.40	0.00	31.01	0.80	118.18	53,718	100%
204	0.1	241,951	5.2	0.30	0.39	0.00	31.01	0.77	118.17	53,715	100%

**Sediment Basin #2 Colon Mine Phase 2 Hydrograph
100-Yr Storm**

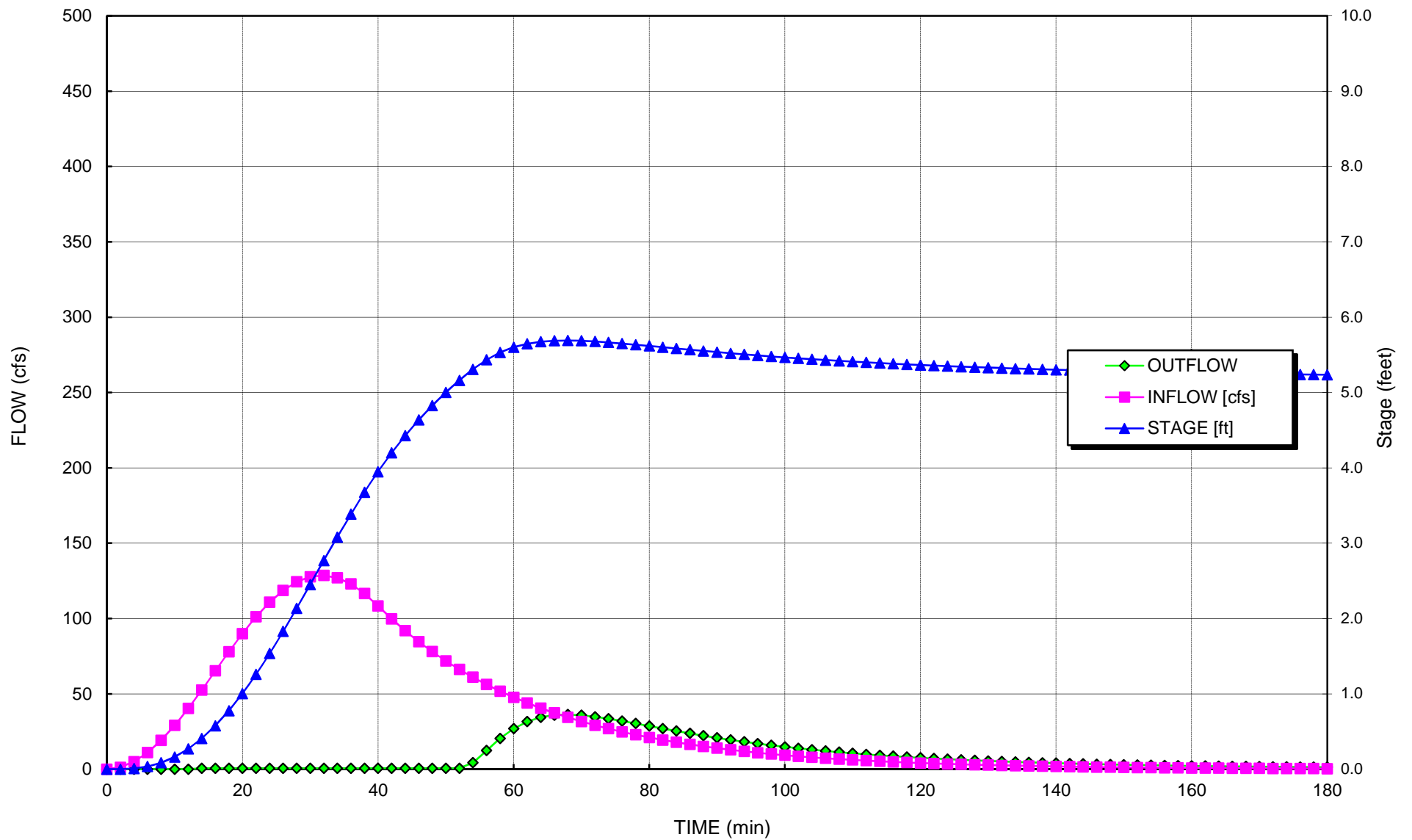

Project: Charah Colon Mine	Computed: PAW	Date: 3/4/15
Subject: Permit Application	Checked: MDP	Date: 3/6/15
Task: Sediment Basin #3	Sheet: 1	Of: 4

Objective Design the temporary sediment basin to contain the 25-year storm.

References

1. NC Erosion and Sediment Control Planning and Design Manual.
2. "Elements of Urban Stormwater Design" by H. Rooney Malcom, P.E.
3. NOAA Atlas 14, Volume 2, Version 3
4. VA Erosion and Sediment Control Handbook

Given

Phase	1	1		
Storm Event (yrs) =	10	25		
Total Drainage Area A (ac) =	3.1	3.1		
Disturbed Area (ac) =	3.1	3.1		
Curve Number CN =	91	91	Hydrographs	
Rainfall Depth P (in) =	5.28	6.28	(24-hr rainfall)	Ref 3
Peak Flow Q _p (cfs) =	20.57	24.96	Hydrographs	

Design Criteria

Required sediment storage	1,800	cf / acre of drainage
Required sediment storage	5,580	cf
Required Surface Area	435	sf/cfs of the 10-yr storm peak flow (based on the largest Phase in cfs)
Required Surface Area (SF)	8,948	of the 10-yr storm peak flow (based on the largest Phase)

Determine Shape of Basin:

Measure the area of the Basin using AutoCADD.

Calculate Volume of the Basin using Truncated Pyramid Method.

Shape factor used in hydrographs basin depth may be greater than indicated below

Elevation (ft)	Depth (ft)	Area (sf)	Volume (cf)	Cumulative Vol (cf)	Cumulative Vol (cy)
244	0	0	-	-	-
244	0	4,877	0	0	0
245	1	6,254	5,551	5,551	206
246	2	7,709	6,969	12,520	464
247	3	9,244	8,465	20,985	777
248	4	10,857	10,040	31,025	1,149
249	5	12,549	11,693	42,717	1,582
250	6	14,321	13,425	56,143	2,079

Design Sediment Depth (ft) = 3

Sediment Storage (cf) = 20,985

Required Sediment Storage Achieved

Design Surface Area Depth (ft) = 3

Surface Area (sf) = 9,244

Required Surface Area Achieved

Project: Charah Colon Mine	Computed: PAW	Date: 3/4/15
Subject: Permit Application	Checked: MDP	Date: 3/6/15
Task: Sediment Basin #3	Sheet: 2	Of: 4

Select Skimmer

A. R. Jarrett Method

$$D = [Q / (2,310 * (H^{0.5}))^{0.5}$$

D = Diameter of Orifice (inches)
 Q = Dewater Rate (cf/day)
 H = Head on orifice, varies based on skimmer size (ft)

Skimmer Sizes (Inches)	Head (ft)
1.5	0.125
2	0.167
2.5	0.167
3	0.250
4	0.333
5	0.333
6	0.417
8	0.500

Volume to Dewater (cf) =	20,985		
Number of Skimmers	1		
Days to Drain =	5	<i>assumed</i>	
Q each (cf/day) =	4,197		0.05 cfs
Selected Skimmer Size (inches) =	2.5		
Head on Skimmer (feet) =	0.208		
Diameter of Orifice (inches) =	2.0		

Route the flow through the Basin

Riser is not perforated, but skimmer is attached.

$$S = (1000/CN) - 10$$

$$\text{Runoff Depth } Q^* \text{ (inches)} = (P-0.2S)^2 / (P+0.8S)$$

$$T_p \text{ (min)} = 60.5(Q^*)A/Q_p / 1.39$$

Ref 2, III-4

Phase	1	1
Storm Event (yrs) =	10	25
S =	0.99	0.99
Runoff Depth Q* (inches) =	4.25	5.23
Time to Peak T _p (min) =	27.91	28.28

Determine Pond Storage Elevation (Z_{water}):

Pick one point near max expected water surface and the other at the mid depth.

$$Z_1 \text{ (ft)} = 3 \quad S_1 \text{ (cf)} = 20,985$$

$$Z_2 \text{ (ft)} = 6 \quad S_2 \text{ (cf)} = 56,143$$

$$b = \ln(S_2/S_1) / \ln(Z_2/Z_1) = 1.4$$

$$K_S = S_2 / Z_2^b = 4,411$$

Ref 2, III-8

Project: Charah Colon Mine	Computed: PAW	Date: 3/4/15
Subject: Permit Application	Checked: MDP	Date: 3/6/15
Task: Sediment Basin #3	Sheet: 3	Of: 4

Determine Settling Velocity

Conversion Factor =	3.281 ft/sec per m/sec	
Gravitational Acceleration, g (m/s ²) =	9.81	
Specific Gravity of soil (s _s) =	2.6	
Kinematic Viscosity of water (ν) =	1.14E-06 m ² / sec @ 20° C	Ref2, IV-11
Diameter of the Design Particle d ₁₅ =	40.00E-06 m	
Design Particle Settling Velocity =	$(g / 18) * [(s_s - 1) / \nu] d^2 =$	4.02E-03 ft/sec

Route the Storm through the Basin using the Hydrograph Model

Set Height of Emergency Spillway at (ft) = 5.00	<i>See Hydrograph</i>
Set Top of Dam at (ft) = 6.00	

Anti-Seep Collar:

Anti-Seep Collar Size = 2 * Barrel Dia
Anti-Seep Collar Size (ft) = 2
Use Anti-Seep Collar Size (ft) = 2 x 2

Minimum Concrete Base for Riser:

Diameter of Riser (in) = 24	From Hydrograph
Avg Density of Concrete (lbs/cf) = 87.6	
Density of Water (lbs/cf) = 62.4	
Riser Displacement (cf) = 13.82	Pi * (D _R /24) ² * Total Ht of Riser
Convert cf to cy = 27 ⁻¹	
Min Concrete Needed (cy) = 0.36	
Width & Length (ft) = 3	
Thickness (ft) = 1.1	

Anti-Vortex Device:

Diameter of Riser (in) = 24	From Hydrograph	
Cylinder Diameter (in) = 36		Ref4, III-104, Table 3.14-D
Cylinder Thickness (gage) = 16		
Cylinder Height (in) = 13		

Project: Charah Colon Mine	Computed: PAW	Date: 3/4/15
Subject: Permit Application	Checked: MDP	Date: 3/6/15
Task: Sediment Basin #3	Sheet: 4	Of: 4

Determine Tailwater conditions to size outlet apron

Use Normal Depth Procedure (Manning's Eqn.)

Ref 2, II-7

$$A \cdot R^{2/3} = Q \cdot n / 1.49 \text{ s}^{0.5}$$

$$Z_{req} = Q \cdot n / 1.49 \text{ s}^{0.5}$$

$$\text{Area (A)} = bd + z(d^2)$$

$$R = \text{Area} / (b + 2d((z^2) + 1)^{0.5})$$

$$Z_{av} = A \cdot R^{2/3}$$

- n = 0.069 6-inch diameter Rip Rap, Lined Channel
- V_p (ft/sec) = 9 Permissible Velocity for lining
- Side Slope (z) = 5 enter X for X:1
- s (ft/ft) = 0.02 Outlet Slope (estimated)
- Bottom Width (ft) = 3 3 * Barrel Diameter
- Q_B (cfs) = 4.1 Peak Flow out of the barrel 10-yr Hydrograph

Q (cfs)	Z _{req}	Flow Depth d (ft)	A (sf)	R (ft)	Z _{av}	V (ft/sec)
4.1	1.34	0.50	2.8	0.34	1.34	1.5

Flow Depth = Tailwater, d (ft) = 0.50 0.5* Barrel Diameter (ft) = 0.50

Ref 1, 8.06.3

Minimum Tailwater Conditions: d < 0.5 * Diameter of Outlet Pipe

Maximum Tailwater Conditions: d > 0.5 * Diameter of Outlet Pipe

Since the Tailwater is less than half of the diameter of the outlet, use Minimum Tailwater conditions.

Barrel Diameter (ft)	Entrance (ft)	Length (ft)	Outlet Width (ft)	Median Rip Rap Size d ₅₀	Selected Rip Rap Size (in)
1	3	8	9	0.4	Class A

Conclusion

The temporary basin can contain the 25-yr storm.

HDR Computation

Project:	Charah Colon Mine	Computed:	PAW	Date:	3/4/15
Subject:	Permit Application	Checked:	MDP	Date:	3/6/15
Task:	Riser Pipe Perforations/Skimmer Flow	Sheet	1	Of	2

Diameter of Riser (in) = 24
 Circumference of Riser (in) = 75.4
 Height of Riser from bottom of barrel (in) = 53 From Hydrograph
 Vertical spacing between holes (in) = 0 center to center
 Water Stage increment (ft) 0.05

Orifice Equation

$$Q = C_d * A * (2 * g * h)^{0.5}$$

Q = cfs, discharge Ref 1, p III-11
 C_d = 0.6 coefficient of discharge
 A = sf, cross sectional area
 g = 32.2 ft/sec², gravity
 h = ft, driving head measured from the center of the pipe

Row	Perforations					Skimmer	# of skimmers
	1	2	3	4	5	1	
Holes per row	0	0	0	0	0		
Hole Diameter (in)	0.75	0.75	0.75	0.75	0.75		
Spacing edge to edge (in)							
Inlet Area (sf)	0.000	0.000	0.000	0.000	0.000		
Hole Stage (in)	0.50	0.50	0.50	0.50	0.50		
Hole Stage (ft)	0.04	0.04	0.04	0.04	0.04		

Water Stage (ft)	Flow (cfs)	Flow (cfs)	Flow (cfs)	Flow (cfs)	Flow (cfs)	Flow (cfs)	Total Flow (cfs)
0.00	0.00	0.00	0.00			0.00	0.00
0.04	0.00	0.00	0.00			0.00	0.00
0.09	0.00	0.00	0.00			0.00	0.00
0.14	0.00	0.00	0.00			0.00	0.00
0.19	0.00	0.00	0.00			0.00	0.00
0.24	0.00	0.00	0.00			0.05	0.05
0.29	0.00	0.00	0.00			0.05	0.05
0.34	0.00	0.00	0.00			0.05	0.05
0.39	0.00	0.00	0.00			0.05	0.05
0.44	0.00	0.00	0.00			0.05	0.05
0.49	0.00	0.00	0.00			0.05	0.05
0.54	0.00	0.00	0.00			0.05	0.05
0.59	0.00	0.00	0.00			0.05	0.05
0.64	0.00	0.00	0.00			0.05	0.05
0.69	0.00	0.00	0.00			0.05	0.05
0.74	0.00	0.00	0.00			0.05	0.05
0.79	0.00	0.00	0.00			0.05	0.05
0.84	0.00	0.00	0.00			0.05	0.05
0.89	0.00	0.00	0.00			0.05	0.05
0.94	0.00	0.00	0.00			0.05	0.05
0.99	0.00	0.00	0.00			0.05	0.05
1.04	0.00	0.00	0.00			0.05	0.05
1.09	0.00	0.00	0.00			0.05	0.05
1.14	0.00	0.00	0.00			0.05	0.05
1.19	0.00	0.00	0.00			0.05	0.05
1.24	0.00	0.00	0.00			0.05	0.05
1.29	0.00	0.00	0.00			0.05	0.05
1.34	0.00	0.00	0.00			0.05	0.05
1.39	0.00	0.00	0.00			0.05	0.05
1.44	0.00	0.00	0.00			0.05	0.05
1.49	0.00	0.00	0.00			0.05	0.05
1.54	0.00	0.00	0.00			0.05	0.05
1.59	0.00	0.00	0.00			0.05	0.05

HDR Computation

Project:	Charah Colon Mine	Computed: PAW	Date: 3/4/15
Subject:	Permit Application	Checked: MDP	Date: 3/6/15
Task:	Riser Pipe Perforations/Skimmer Flow	Sheet 2	Of 2

1.64	0.00	0.00	0.00	0.05	0.05
1.69	0.00	0.00	0.00	0.05	0.05
1.74	0.00	0.00	0.00	0.05	0.05
1.79	0.00	0.00	0.00	0.05	0.05
1.84	0.00	0.00	0.00	0.05	0.05
1.89	0.00	0.00	0.00	0.05	0.05
1.94	0.00	0.00	0.00	0.05	0.05
1.99	0.00	0.00	0.00	0.05	0.05
2.04	0.00	0.00	0.00	0.05	0.05
2.09	0.00	0.00	0.00	0.05	0.05
2.14	0.00	0.00	0.00	0.05	0.05
2.19	0.00	0.00	0.00	0.05	0.05
2.24	0.00	0.00	0.00	0.05	0.05
2.29	0.00	0.00	0.00	0.05	0.05
2.34	0.00	0.00	0.00	0.05	0.05
2.39	0.00	0.00	0.00	0.05	0.05
2.44	0.00	0.00	0.00	0.05	0.05
2.49	0.00	0.00	0.00	0.05	0.05
2.54	0.00	0.00	0.00	0.05	0.05
2.59	0.00	0.00	0.00	0.05	0.05
2.64	0.00	0.00	0.00	0.05	0.05
2.69	0.00	0.00	0.00	0.05	0.05
2.74	0.00	0.00	0.00	0.05	0.05
2.79	0.00	0.00	0.00	0.05	0.05
2.84	0.00	0.00	0.00	0.05	0.05
2.89	0.00	0.00	0.00	0.05	0.05
2.94	0.00	0.00	0.00	0.05	0.05
2.99	0.00	0.00	0.00	0.05	0.05
3.04	0.00	0.00	0.00	0.05	0.05
3.09	0.00	0.00	0.00	0.05	0.05
3.14	0.00	0.00	0.00	0.05	0.05
3.19	0.00	0.00	0.00	0.05	0.05
3.24	0.00	0.00	0.00	0.05	0.05
3.29	0.00	0.00	0.00	0.05	0.05
3.34	0.00	0.00	0.00	0.05	0.05
3.39	0.00	0.00	0.00	0.05	0.05
3.44	0.00	0.00	0.00	0.05	0.05
3.49	0.00	0.00	0.00	0.05	0.05
3.54	0.00	0.00	0.00	0.05	0.05
3.59	0.00	0.00	0.00	0.05	0.05
3.64	0.00	0.00	0.00	0.05	0.05
3.69	0.00	0.00	0.00	0.05	0.05
3.74	0.00	0.00	0.00	0.05	0.05
3.79	0.00	0.00	0.00	0.05	0.05
3.84	0.00	0.00	0.00	0.05	0.05
3.89	0.00	0.00	0.00	0.05	0.05
3.94	0.00	0.00	0.00	0.05	0.05
3.99	0.00	0.00	0.00	0.05	0.05

Sediment Basin # 3 Colon

Qp = 20.57 cfs
 Tp = 27.91 minutes
 dT = Max of 2 minutes
 or 1.0% of increment to peak

Phase 1
 10 - year Storm Event

b = 1.4
 K_s = 4,411

Number of Riser/Barrel Assemblies = 1
 Diameter of Barrel = 12 (in)
 Height of Riser above barrel = 3.4 (ft)
 Height of Riser from bottom of barrel = 4.4 (ft) elevation 248.40
 Emergency Spillway = 5.0 (ft) elevation 249.00
 Total Height of Dam = 6.0 (ft) elevation 250.00
 Length of Emergency Spillway = 10 (ft)
 Diameter of Riser = 24 (in)
 Permanent Pond Stage = 0 (ft) elevation 244.0

4.0E-03 Settling Velocity of design particle (fps)
 2 Effective number of cells (2 is construction site #)
 98% Minimum Settling Efficiency
 4.7 ft Maximum Stage 248.74 msl elevation
 4.1 cfs Peak outflow
 4.1 cfs Peak Riser/Barrel outflow
 0.0 cfs Peak Weir flow

Notes:

1. Length of emergency spillway is the bottom width of the emergency spillway.
2. Settling efficiency neglects permanent pond volume

TIME	INFLOW	STORAGE	STAGE	Skimmer	RISER	WEIR	BARREL	TOTAL	Bound	Estimated	Settling
(min)	[cfs]	[cu ft]	[ft]	Flow [cfs]	CAPACIT	FLOW	CAPACITY	OUTFLOW	Discharge	Surface	Efficiency
					Y [cfs]	[cfs]	[cfs]	[cfs]	[cfs]	Area (sf)	[%]
0	0.0	0	0.0	0.00	0.00	0.00	0.00	0.00	0.00	-	N/A
2	0.3	0	0.0	0.00	0.00	0.00	0.00	0.00	0.00	-	N/A
4	1.0	31	0.0	0.00	0.00	0.00	0.00	0.00	3.19	1,448	N/A
6	2.3	154	0.1	0.00	0.00	0.00	0.00	0.00	5.11	2,323	N/A
8	3.9	425	0.2	0.00	0.00	0.00	0.00	0.00	6.90	3,136	N/A
10	5.9	893	0.3	0.05	0.05	0.00	0.05	0.05	8.59	3,905	100%
12	8.0	1,590	0.5	0.05	0.05	0.00	0.05	0.05	10.19	4,631	100%
14	10.3	2,549	0.7	0.05	0.05	0.00	0.05	0.05	11.72	5,325	100%
16	12.6	3,784	0.9	0.05	0.05	0.00	0.05	0.05	13.17	5,985	100%
18	14.8	5,294	1.1	0.05	0.05	0.00	0.05	0.05	14.54	6,610	100%
20	16.8	7,066	1.4	0.05	0.05	0.00	0.05	0.05	15.84	7,198	100%
22	18.4	9,071	1.7	0.05	0.05	0.00	0.05	0.05	17.05	7,750	100%
24	19.6	11,271	1.9	0.05	0.05	0.00	0.05	0.05	18.18	8,264	100%
26	20.3	13,616	2.2	0.05	0.05	0.00	0.05	0.05	19.23	8,739	100%
28	20.6	16,050	2.5	0.05	0.05	0.00	0.05	0.05	20.18	9,174	100%
30	20.3	18,513	2.7	0.05	0.05	0.00	0.05	0.05	21.05	9,570	100%
32	19.5	20,941	3.0	0.05	0.05	0.00	0.05	0.05	21.83	9,925	100%
34	18.2	23,275	3.2	0.05	0.05	0.00	0.05	0.05	22.53	10,240	100%
36	16.7	25,458	3.4	0.05	0.05	0.00	0.05	0.05	23.13	10,515	100%
38	15.2	27,455	3.6	0.05	0.05	0.00	0.05	0.05	23.66	10,752	100%
40	13.9	29,273	3.8	0.05	0.05	0.00	0.05	0.05	24.11	10,958	100%
42	12.6	30,929	3.9	0.05	0.05	0.00	0.05	0.05	24.50	11,138	100%
44	11.5	32,438	4.1	0.05	0.05	0.00	0.05	0.05	24.85	11,296	100%
46	10.5	33,811	4.2	0.05	0.05	0.00	0.05	0.05	25.16	11,435	100%
48	9.5	35,062	4.3	0.05	0.05	0.00	0.05	0.05	25.43	11,559	100%
50	8.7	36,201	4.4	0.05	0.06	0.00	7.46	0.06	25.67	11,668	100%
52	7.9	37,238	4.5	0.05	0.64	0.00	7.54	0.64	25.89	11,766	100%
54	7.2	38,111	4.6	0.05	1.47	0.00	7.61	1.47	26.06	11,847	100%
56	6.6	38,801	4.6	0.05	2.27	0.00	7.67	2.27	26.20	11,910	99%
58	6.0	39,318	4.7	0.05	2.94	0.00	7.71	2.94	26.30	11,957	99%
60	5.5	39,684	4.7	0.05	3.44	0.00	7.74	3.44	26.38	11,990	98%
62	5.0	39,926	4.7	0.05	3.79	0.00	7.76	3.79	26.42	12,011	98%
64	4.5	40,068	4.7	0.05	4.00	0.00	7.77	4.00	26.45	12,024	98%
66	4.1	40,131	4.7	0.05	4.09	0.00	7.77	4.09	26.46	12,029	98%
68	3.8	40,135	4.7	0.05	4.10	0.00	7.77	4.10	26.47	12,030	98%
70	3.4	40,094	4.7	0.05	4.04	0.00	7.77	4.04	26.46	12,026	98%
72	3.1	40,020	4.7	0.05	3.93	0.00	7.76	3.93	26.44	12,020	98%
74	2.8	39,923	4.7	0.05	3.79	0.00	7.76	3.79	26.42	12,011	98%
76	2.6	39,810	4.7	0.05	3.62	0.00	7.75	3.62	26.40	12,001	98%
78	2.4	39,686	4.7	0.05	3.44	0.00	7.74	3.44	26.38	11,990	98%
80	2.1	39,556	4.7	0.05	3.26	0.00	7.73	3.26	26.35	11,978	99%
82	2.0	39,422	4.7	0.05	3.08	0.00	7.72	3.08	26.33	11,966	99%

84	1.8	39,288	4.7	0.05	2.89	0.00	7.71	2.89	26.30	11,954	99%
86	1.6	39,155	4.7	0.05	2.72	0.00	7.70	2.72	26.27	11,942	99%
88	1.5	39,023	4.6	0.05	2.55	0.00	7.69	2.55	26.25	11,930	99%
90	1.3	38,896	4.6	0.05	2.38	0.00	7.68	2.38	26.22	11,919	99%
92	1.2	38,771	4.6	0.05	2.23	0.00	7.67	2.23	26.20	11,907	99%
94	1.1	38,651	4.6	0.05	2.08	0.00	7.66	2.08	26.17	11,896	99%
96	1.0	38,536	4.6	0.05	1.94	0.00	7.65	1.94	26.15	11,886	99%
98	0.9	38,425	4.6	0.05	1.82	0.00	7.64	1.82	26.13	11,876	99%
100	0.8	38,318	4.6	0.05	1.69	0.00	7.63	1.69	26.11	11,866	100%
102	0.8	38,217	4.6	0.05	1.58	0.00	7.62	1.58	26.08	11,857	100%
104	0.7	38,119	4.6	0.05	1.48	0.00	7.62	1.48	26.07	11,848	100%
106	0.6	38,027	4.6	0.05	1.38	0.00	7.61	1.38	26.05	11,839	100%
108	0.6	37,938	4.6	0.05	1.28	0.00	7.60	1.28	26.03	11,831	100%
110	0.5	37,854	4.5	0.05	1.20	0.00	7.59	1.20	26.01	11,823	100%
112	0.5	37,774	4.5	0.05	1.12	0.00	7.59	1.12	26.00	11,816	100%
114	0.4	37,698	4.5	0.05	1.05	0.00	7.58	1.05	25.98	11,809	100%
116	0.4	37,625	4.5	0.05	0.98	0.00	7.58	0.98	25.96	11,802	100%
118	0.4	37,556	4.5	0.05	0.91	0.00	7.57	0.91	25.95	11,796	100%
120	0.3	37,490	4.5	0.05	0.85	0.00	7.57	0.85	25.94	11,790	100%
122	0.3	37,428	4.5	0.05	0.80	0.00	7.56	0.80	25.92	11,784	100%
124	0.3	37,369	4.5	0.05	0.75	0.00	7.56	0.75	25.91	11,778	100%
126	0.3	37,312	4.5	0.05	0.70	0.00	7.55	0.70	25.90	11,773	100%
128	0.2	37,258	4.5	0.05	0.66	0.00	7.55	0.66	25.89	11,768	100%
130	0.2	37,207	4.5	0.05	0.61	0.00	7.54	0.61	25.88	11,763	100%
132	0.2	37,159	4.5	0.05	0.58	0.00	7.54	0.58	25.87	11,759	100%
134	0.2	37,112	4.5	0.05	0.54	0.00	7.53	0.54	25.86	11,754	100%
136	0.2	37,068	4.5	0.05	0.51	0.00	7.53	0.51	25.85	11,750	100%
138	0.1	37,026	4.5	0.05	0.48	0.00	7.53	0.48	25.84	11,746	100%
140	0.1	36,987	4.5	0.05	0.45	0.00	7.52	0.45	25.83	11,743	100%
142	0.1	36,949	4.5	0.05	0.42	0.00	7.52	0.42	25.83	11,739	100%
144	0.1	36,912	4.5	0.05	0.40	0.00	7.52	0.40	25.82	11,736	100%
146	0.1	36,878	4.5	0.05	0.37	0.00	7.52	0.37	25.81	11,732	100%
148	0.1	36,845	4.5	0.05	0.35	0.00	7.51	0.35	25.80	11,729	100%
150	0.1	36,814	4.5	0.05	0.33	0.00	7.51	0.33	25.80	11,726	100%
152	0.1	36,784	4.5	0.05	0.31	0.00	7.51	0.31	25.79	11,724	100%
154	0.1	36,755	4.5	0.05	0.30	0.00	7.51	0.30	25.79	11,721	100%
156	0.1	36,728	4.4	0.05	0.28	0.00	7.50	0.28	25.78	11,718	100%
158	0.1	36,702	4.4	0.05	0.26	0.00	7.50	0.26	25.77	11,716	100%
160	0.1	36,677	4.4	0.05	0.25	0.00	7.50	0.25	25.77	11,714	100%
162	0.0	36,653	4.4	0.05	0.24	0.00	7.50	0.24	25.76	11,711	100%
164	0.0	36,631	4.4	0.05	0.22	0.00	7.50	0.22	25.76	11,709	100%
166	0.0	36,609	4.4	0.05	0.21	0.00	7.49	0.21	25.76	11,707	100%
168	0.0	36,588	4.4	0.05	0.20	0.00	7.49	0.20	25.75	11,705	100%
170	0.0	36,568	4.4	0.05	0.19	0.00	7.49	0.19	25.75	11,703	100%
172	0.0	36,549	4.4	0.05	0.18	0.00	7.49	0.18	25.74	11,701	100%
174	0.0	36,531	4.4	0.05	0.17	0.00	7.49	0.17	25.74	11,700	100%
176	0.0	36,513	4.4	0.05	0.16	0.00	7.49	0.16	25.74	11,698	100%
178	0.0	36,497	4.4	0.05	0.16	0.00	7.49	0.16	25.73	11,696	100%
180	0.0	36,481	4.4	0.05	0.15	0.00	7.48	0.15	25.73	11,695	100%
182	0.0	36,465	4.4	0.05	0.14	0.00	7.48	0.14	25.73	11,693	100%
184	0.0	36,450	4.4	0.05	0.14	0.00	7.48	0.14	25.72	11,692	100%
186	0.0	36,436	4.4	0.05	0.13	0.00	7.48	0.13	25.72	11,691	100%
188	0.0	36,422	4.4	0.05	0.12	0.00	7.48	0.12	25.72	11,689	100%
190	0.0	36,409	4.4	0.05	0.12	0.00	7.48	0.12	25.71	11,688	100%
192	0.0	36,396	4.4	0.05	0.11	0.00	7.48	0.11	25.71	11,687	100%
194	0.0	36,384	4.4	0.05	0.11	0.00	7.48	0.11	25.71	11,686	100%
196	0.0	36,372	4.4	0.05	0.10	0.00	7.47	0.10	25.71	11,685	100%
198	0.0	36,361	4.4	0.05	0.10	0.00	7.47	0.10	25.70	11,684	100%
200	0.0	36,350	4.4	0.05	0.10	0.00	7.47	0.10	25.70	11,683	100%
202	0.0	36,339	4.4	0.05	0.09	0.00	7.47	0.09	25.70	11,682	100%
204	0.0	36,329	4.4	0.05	0.09	0.00	7.47	0.09	25.70	11,681	100%
206	0.0	36,319	4.4	0.05	0.09	0.00	7.47	0.09	25.70	11,680	100%

**Sediment Basin #3 Colon Mine Phase 1 Hydrograph
10-Yr Storm**

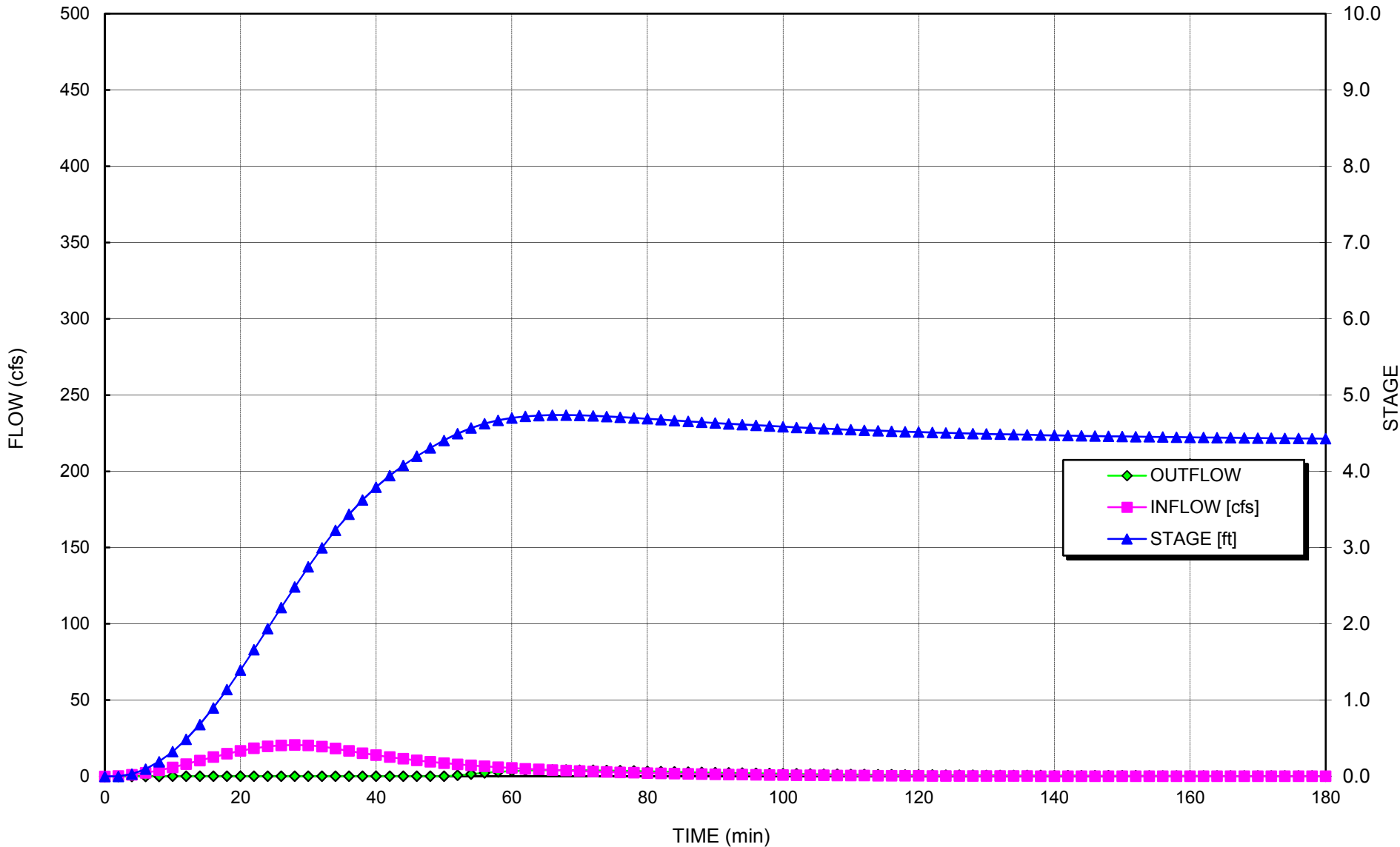

This page intentionally left blank.

Sediment Basin # 3 Colon

Qp = 24.96 cfs
 Tp = 28.28 minutes
 dT = Max of 2 minutes
 or 1.0% of increment to peak

Phase 1
 25 - year Storm Event

b = 1.4
 K_s = 4,411

Number of Riser/Barrel Assemblies = 1
 Diameter of Barrel = 12 (in)
 Height of Riser above barrel = 3.4 (ft)
 Height of Riser from bottom of barrel = 4.4 (ft) elevation 248.40
 Emergency Spillway = 5.0 (ft) elevation 249.00
 Total Height of Dam = 6.0 (ft) elevation 250.00
 Length of Emergency Spillway = 10 (ft)
 Diameter of Riser = 24 (in)
 Permanent Pond Stage = 0 (ft) elevation 244.0

4.0E-03 Settling Velocity of design particle (fps)
 2 Effective number of cells (2 is construction site #)
 94% Minimum Settling Efficiency
 5.0 ft Maximum Stage 248.98 msl elevation
 8.0 cfs Peak outflow
 8.0 cfs Peak Riser/Barrel outflow
 0.0 cfs Peak Weir flow

Notes:

1. Length of emergency spillway is the bottom width of the emergency spillway.
2. Settling efficiency neglects permanent pond volume

TIME	INFLOW	STORAGE	STAGE	Skimmer	RISER	WEIR	BARREL	TOTAL	Bound	Estimated	Settling
(min)	[cfs]	[cu ft]	[ft]	Flow [cfs]	CAPACIT	FLOW	CAPACITY	OUTFLOW	Discharge	Surface	Efficiency
					Y [cfs]	[cfs]	[cfs]	[cfs]	[cfs]	Area (sf)	[%]
0	0.0	0	0.0	0.00	0.00	0.00	0.00	0.00	0.00	-	N/A
2	0.3	0	0.0	0.00	0.00	0.00	0.00	0.00	0.00	-	N/A
4	1.2	37	0.0	0.00	0.00	0.00	0.00	0.00	3.35	1,521	N/A
6	2.7	182	0.1	0.00	0.00	0.00	0.00	0.00	5.37	2,441	N/A
8	4.6	503	0.2	0.00	0.00	0.00	0.00	0.00	7.25	3,295	N/A
10	6.9	1,056	0.4	0.05	0.05	0.00	0.05	0.05	9.03	4,104	100%
12	9.5	1,883	0.5	0.05	0.05	0.00	0.05	0.05	10.71	4,869	100%
14	12.3	3,022	0.8	0.05	0.05	0.00	0.05	0.05	12.32	5,600	100%
16	15.0	4,491	1.0	0.05	0.05	0.00	0.05	0.05	13.85	6,296	100%
18	17.7	6,290	1.3	0.05	0.05	0.00	0.05	0.05	15.30	6,955	100%
20	20.0	8,404	1.6	0.05	0.05	0.00	0.05	0.05	16.67	7,577	100%
22	22.0	10,803	1.9	0.05	0.05	0.00	0.05	0.05	17.95	8,161	100%
24	23.6	13,443	2.2	0.05	0.05	0.00	0.05	0.05	19.15	8,706	100%
26	24.6	16,266	2.5	0.05	0.05	0.00	0.05	0.05	20.26	9,211	100%
28	25.0	19,208	2.8	0.05	0.05	0.00	0.05	0.05	21.28	9,675	100%
30	24.7	22,196	3.1	0.05	0.05	0.00	0.05	0.05	22.21	10,097	100%
32	23.9	25,158	3.4	0.05	0.05	0.00	0.05	0.05	23.05	10,478	100%
34	22.5	28,022	3.7	0.05	0.05	0.00	0.05	0.05	23.80	10,817	100%
36	20.7	30,719	3.9	0.05	0.05	0.00	0.05	0.05	24.45	11,115	100%
38	18.9	33,197	4.1	0.05	0.05	0.00	0.05	0.05	25.02	11,373	100%
40	17.2	35,458	4.3	0.05	0.05	0.00	0.05	0.05	25.51	11,597	100%
42	15.7	37,519	4.5	0.05	0.88	0.00	7.57	0.88	25.94	11,792	100%
44	14.3	39,299	4.7	0.05	2.91	0.00	7.71	2.91	26.30	11,955	99%
46	13.1	40,670	4.8	0.05	4.93	0.00	7.81	4.93	26.57	12,077	97%
48	11.9	41,648	4.9	0.05	6.55	0.00	7.89	6.55	26.76	12,162	96%
50	10.9	42,292	4.9	0.05	7.70	0.00	7.93	7.70	26.88	12,217	94%
52	9.9	42,673	4.9	0.05	8.41	0.00	7.96	7.96	26.95	12,250	94%
54	9.1	42,908	5.0	0.05	8.85	0.00	7.98	7.98	26.99	12,270	94%
56	8.3	43,037	5.0	0.05	9.10	0.00	7.99	7.99	27.02	12,281	94%
58	7.5	43,069	5.0	0.05	9.16	0.00	7.99	7.99	27.02	12,283	94%
60	6.9	43,014	5.0	0.05	9.06	0.00	7.99	7.99	27.01	12,279	94%
62	6.3	42,880	5.0	0.05	8.80	0.00	7.98	7.98	26.99	12,267	94%
64	5.7	42,675	4.9	0.05	8.41	0.00	7.96	7.96	26.95	12,250	94%
66	5.2	42,405	4.9	0.05	7.91	0.00	7.94	7.91	26.90	12,227	94%
68	4.8	42,082	4.9	0.05	7.32	0.00	7.92	7.32	26.84	12,199	95%
70	4.3	41,774	4.9	0.05	6.77	0.00	7.89	6.77	26.78	12,173	95%
72	4.0	41,481	4.8	0.05	6.27	0.00	7.87	6.27	26.72	12,148	96%
74	3.6	41,204	4.8	0.05	5.80	0.00	7.85	5.80	26.67	12,124	96%
76	3.3	40,941	4.8	0.05	5.36	0.00	7.83	5.36	26.62	12,101	97%
78	3.0	40,693	4.8	0.05	4.96	0.00	7.81	4.96	26.57	12,079	97%
80	2.7	40,457	4.8	0.05	4.59	0.00	7.80	4.59	26.53	12,058	97%
82	2.5	40,235	4.7	0.05	4.25	0.00	7.78	4.25	26.48	12,039	98%

84	2.3	40,025	4.7	0.05	3.94	0.00	7.76	3.94	26.44	12,020	98%
86	2.1	39,826	4.7	0.05	3.64	0.00	7.75	3.64	26.40	12,002	98%
88	1.9	39,638	4.7	0.05	3.38	0.00	7.73	3.38	26.37	11,985	98%
90	1.7	39,461	4.7	0.05	3.13	0.00	7.72	3.13	26.33	11,970	99%
92	1.6	39,293	4.7	0.05	2.90	0.00	7.71	2.90	26.30	11,955	99%
94	1.4	39,134	4.7	0.05	2.69	0.00	7.69	2.69	26.27	11,940	99%
96	1.3	38,984	4.6	0.05	2.50	0.00	7.68	2.50	26.24	11,927	99%
98	1.2	38,842	4.6	0.05	2.32	0.00	7.67	2.32	26.21	11,914	99%
100	1.1	38,708	4.6	0.05	2.15	0.00	7.66	2.15	26.18	11,902	99%
102	1.0	38,581	4.6	0.05	2.00	0.00	7.65	2.00	26.16	11,890	99%
104	0.9	38,460	4.6	0.05	1.86	0.00	7.64	1.86	26.13	11,879	99%
106	0.8	38,347	4.6	0.05	1.73	0.00	7.63	1.73	26.11	11,869	100%
108	0.8	38,239	4.6	0.05	1.61	0.00	7.62	1.61	26.09	11,859	100%
110	0.7	38,137	4.6	0.05	1.49	0.00	7.62	1.49	26.07	11,849	100%
112	0.6	38,041	4.6	0.05	1.39	0.00	7.61	1.39	26.05	11,841	100%
114	0.6	37,949	4.6	0.05	1.30	0.00	7.60	1.30	26.03	11,832	100%
116	0.5	37,863	4.5	0.05	1.21	0.00	7.59	1.21	26.01	11,824	100%
118	0.5	37,780	4.5	0.05	1.13	0.00	7.59	1.13	26.00	11,817	100%
120	0.4	37,703	4.5	0.05	1.05	0.00	7.58	1.05	25.98	11,809	100%
122	0.4	37,629	4.5	0.05	0.98	0.00	7.58	0.98	25.97	11,803	100%
124	0.4	37,559	4.5	0.05	0.92	0.00	7.57	0.92	25.95	11,796	100%
126	0.3	37,492	4.5	0.05	0.86	0.00	7.57	0.86	25.94	11,790	100%
128	0.3	37,429	4.5	0.05	0.80	0.00	7.56	0.80	25.92	11,784	100%
130	0.3	37,370	4.5	0.05	0.75	0.00	7.56	0.75	25.91	11,778	100%
132	0.3	37,313	4.5	0.05	0.70	0.00	7.55	0.70	25.90	11,773	100%
134	0.2	37,259	4.5	0.05	0.66	0.00	7.55	0.66	25.89	11,768	100%
136	0.2	37,208	4.5	0.05	0.61	0.00	7.54	0.61	25.88	11,763	100%
138	0.2	37,159	4.5	0.05	0.58	0.00	7.54	0.58	25.87	11,759	100%
140	0.2	37,113	4.5	0.05	0.54	0.00	7.53	0.54	25.86	11,754	100%
142	0.2	37,069	4.5	0.05	0.51	0.00	7.53	0.51	25.85	11,750	100%
144	0.1	37,027	4.5	0.05	0.48	0.00	7.53	0.48	25.84	11,746	100%
146	0.1	36,987	4.5	0.05	0.45	0.00	7.52	0.45	25.83	11,743	100%
148	0.1	36,949	4.5	0.05	0.42	0.00	7.52	0.42	25.83	11,739	100%
150	0.1	36,913	4.5	0.05	0.40	0.00	7.52	0.40	25.82	11,736	100%
152	0.1	36,878	4.5	0.05	0.37	0.00	7.52	0.37	25.81	11,732	100%
154	0.1	36,846	4.5	0.05	0.35	0.00	7.51	0.35	25.80	11,729	100%
156	0.1	36,814	4.5	0.05	0.33	0.00	7.51	0.33	25.80	11,726	100%
158	0.1	36,784	4.5	0.05	0.31	0.00	7.51	0.31	25.79	11,724	100%
160	0.1	36,756	4.5	0.05	0.30	0.00	7.51	0.30	25.79	11,721	100%
162	0.1	36,729	4.4	0.05	0.28	0.00	7.50	0.28	25.78	11,718	100%
164	0.1	36,703	4.4	0.05	0.26	0.00	7.50	0.26	25.78	11,716	100%
166	0.1	36,678	4.4	0.05	0.25	0.00	7.50	0.25	25.77	11,714	100%
168	0.0	36,654	4.4	0.05	0.24	0.00	7.50	0.24	25.76	11,711	100%
170	0.0	36,632	4.4	0.05	0.22	0.00	7.50	0.22	25.76	11,709	100%
172	0.0	36,610	4.4	0.05	0.21	0.00	7.49	0.21	25.76	11,707	100%
174	0.0	36,589	4.4	0.05	0.20	0.00	7.49	0.20	25.75	11,705	100%
176	0.0	36,569	4.4	0.05	0.19	0.00	7.49	0.19	25.75	11,703	100%
178	0.0	36,550	4.4	0.05	0.18	0.00	7.49	0.18	25.74	11,702	100%
180	0.0	36,532	4.4	0.05	0.17	0.00	7.49	0.17	25.74	11,700	100%
182	0.0	36,515	4.4	0.05	0.16	0.00	7.49	0.16	25.74	11,698	100%
184	0.0	36,498	4.4	0.05	0.16	0.00	7.49	0.16	25.73	11,697	100%
186	0.0	36,482	4.4	0.05	0.15	0.00	7.48	0.15	25.73	11,695	100%
188	0.0	36,466	4.4	0.05	0.14	0.00	7.48	0.14	25.73	11,694	100%
190	0.0	36,451	4.4	0.05	0.14	0.00	7.48	0.14	25.72	11,692	100%
192	0.0	36,437	4.4	0.05	0.13	0.00	7.48	0.13	25.72	11,691	100%
194	0.0	36,423	4.4	0.05	0.12	0.00	7.48	0.12	25.72	11,689	100%
196	0.0	36,410	4.4	0.05	0.12	0.00	7.48	0.12	25.71	11,688	100%
198	0.0	36,397	4.4	0.05	0.11	0.00	7.48	0.11	25.71	11,687	100%
200	0.0	36,385	4.4	0.05	0.11	0.00	7.48	0.11	25.71	11,686	100%
202	0.0	36,373	4.4	0.05	0.11	0.00	7.47	0.11	25.71	11,685	100%
204	0.0	36,362	4.4	0.05	0.10	0.00	7.47	0.10	25.70	11,684	100%
206	0.0	36,351	4.4	0.05	0.10	0.00	7.47	0.10	25.70	11,683	100%

**Sediment Basin #3 Colon Mine Phase 1 Hydrograph
25-Yr Storm**

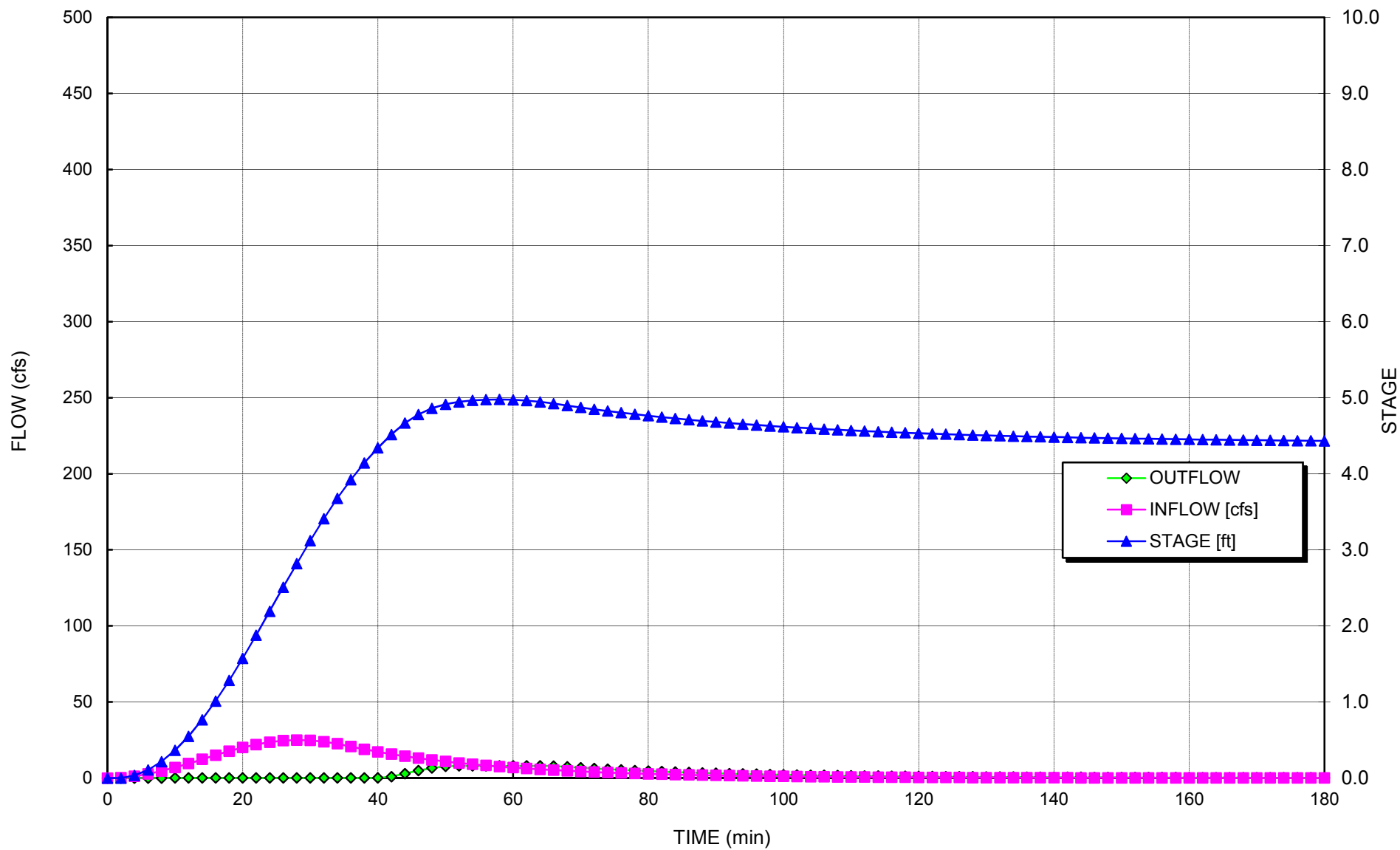

This page intentionally left blank.

Project: Charah Colon Mine	Computed: PAW	Date: 3/4/15
Subject: Permit Application	Checked: MDP	Date: 3/6/15
Task: Sediment Basin #4	Sheet: 1	Of: 4

Objective Design the temporary sediment basin to contain the 25-year storm.

References

1. NC Erosion and Sediment Control Planning and Design Manual.
2. "Elements of Urban Stormwater Design" by H. Rooney Malcom, P.E.
3. NOAA Atlas 14, Volume 2, Version 3
4. VA Erosion and Sediment Control Handbook

Given

	Phase	1	1		
Storm Event (yrs) =		10	25		
Total Drainage Area A (ac) =		12.7	12.7		
Disturbed Area (ac) =		12.7	12.7		
Curve Number CN =		89	89		
Rainfall Depth P (in) =		5.28	6.28	Hydrographs (24-hr rainfall)	Ref 3
Peak Flow Q _p (cfs) =		77.74	95.13	Hydrographs	

Design Criteria

Required sediment storage	1,800	cf / acre of drainage
Required sediment storage	22,860	cf
Required Surface Area	435	sf/cfs of the 10-yr storm peak flow (based on the largest Phase in cfs)
Required Surface Area (SF)	41,382	of the 10-yr storm peak flow (based on the largest Phase)

Determine Shape of Basin:

Measure the area of the Basin using AutoCADD.

Calculate Volume of the Basin using Truncated Pyramid Method.

Shape factor used in hydrographs basin depth may be greater than indicated below

Elevation (ft)	Depth (ft)	Area (sf)	Volume (cf)	Cumulative Vol (cf)	Cumulative Vol (cy)
261	0	26,486	0	0	0
262	1	29,254	27,859	27,859	1,032
263	2	32,108	30,670	58,528	2,168
264	3	35,046	33,566	92,095	3,411
265	4	38,057	36,541	128,636	4,764
266	5	41,127	39,582	168,218	6,230
267	6	44,258	42,683	210,901	7,811

Design Sediment Depth (ft) = 3

Sediment Storage (cf) = 92,095

Required Sediment Storage Achieved

Design Surface Area Depth (ft) = 3

Surface Area (sf) = 35,046

Increase Surface Area

Project: Charah Colon Mine	Computed: PAW	Date: 3/4/15
Subject: Permit Application	Checked: MDP	Date: 3/6/15
Task: Sediment Basin #4	Sheet: 2	Of: 4

Select Skimmer

A. R. Jarrett Method

$$D = [Q / (2,310 * (H^{0.5}))]^{0.5}$$

D = Diameter of Orifice (inches)

Q = Dewater Rate (cf/day)

H = Head on orifice, varies based on skimmer size (ft)

Skimmer Sizes (Inches)	Head (ft)
1.5	0.125
2	0.167
2.5	0.167
3	0.250
4	0.333
5	0.333
6	0.417
8	0.500

Volume to Dewater (cf) =	92,095		
Number of Skimmers	1		
Days to Drain =	5	<i>assumed</i>	
Q each (cf/day) =	18,419		0.21 cfs

Selected Skimmer Size (inches) =	4
Head on Skimmer (feet) =	0.333
Diameter of Orifice (inches) =	3.7

Route the flow through the Basin

Riser is not perforated, but skimmer is attached.

$$S = (1000/CN) - 10$$

$$\text{Runoff Depth } Q^* \text{ (inches)} = (P-0.2S)^2 / (P+0.8S)$$

$$T_p \text{ (min)} = 60.5(Q^*)A/Q_p/1.39$$

Ref2, III-4

Phase	1	1
Storm Event (yrs) =	10	25
S =	1.24	1.24
Runoff Depth Q* (inches) =	4.04	5.01
Time to Peak T _p (min) =	28.73	29.09

Project: Charah Colon Mine	Computed: PAW	Date: 3/4/15
Subject: Permit Application	Checked: MDP	Date: 3/6/15
Task: Sediment Basin #4	Sheet: 3	Of: 4

Determine Pond Storage Elevation (Z_{water}):

Pick one point near max expected water surface and the other at the mid depth.

$$\begin{aligned}
 Z_1 \text{ (ft)} &= 3 & S_1 \text{ (cf)} &= 92,095 \\
 Z_2 \text{ (ft)} &= 5 & S_2 \text{ (cf)} &= 168,218 \\
 b = \ln(S_2/S_1)/\ln(Z_2/Z_1) &= 1.2 & & \text{Ref 2, III-8} \\
 K_S = S_2/Z_2^b &= 25,208 & &
 \end{aligned}$$

Determine Settling Velocity

$$\begin{aligned}
 \text{Conversion Factor} &= 3.281 \text{ ft/sec per m/sec} \\
 \text{Gravitational Acceleration, } g \text{ (m/s}^2\text{)} &= 9.81 \\
 \text{Specific Gravity of soil (s}_s\text{)} &= 2.6 \\
 \text{Kinematic Viscosity of water (}\nu\text{)} &= 1.14\text{E-06 n}^2/\text{sec @ } 20^\circ\text{C} & \text{Ref 2, IV-11} \\
 \text{Diameter of the Design Particle } d_{15} &= 40.00\text{E-06 m} \\
 \\
 \text{Design Particle Settling Velocity} &= (g / 18) * [(s_s - 1) / \nu] d^2 = 4.02\text{E-03 ft/sec}
 \end{aligned}$$

Route the Storm through the Basin using the Hydrograph Model

Set Height of Emergency Spillway at (ft) = 6.00
 Set Top of Dam at (ft) = 6.60 *See Hydrograph*

Anti-Seep Collar:

$$\begin{aligned}
 \text{Anti-Seep Collar Size} &= 2 * \text{Barrel Dia} \\
 \text{Anti-Seep Collar Size (ft)} &= 2 \\
 \text{Use Anti-Seep Collar Size (ft)} &= 2 \quad \times 2
 \end{aligned}$$

Minimum Concrete Base for Riser:

$$\begin{aligned}
 \text{Diameter of Riser (in)} &= 24 & \text{From Hydrograph} \\
 \text{Avg Density of Concrete (lbs/cf)} &= 87.6 \\
 \text{Density of Water (lbs/cf)} &= 62.4 \\
 \text{Riser Displacement (cf)} &= 16.65 & \text{Pi * (D}_R\text{/24)}^2 * \text{Total Ht of Riser} \\
 \text{Convert cf to cy} &= 27^{-1} \\
 \text{Min Concrete Needed (cy)} &= 0.44 \\
 \text{Width \& Length (ft)} &= 3 \\
 \text{Thickness (ft)} &= 1.3
 \end{aligned}$$

Project: Charah Colon Mine	Computed: PAW	Date: 3/4/15
Subject: Permit Application	Checked: MDP	Date: 3/6/15
Task: Sediment Basin #4	Sheet: 4	Of: 4

Anti-Vortex Device:

Diameter of Riser (in) = 24 From Hydrograph
 Cylinder Diameter (in) = 36 Ref 4, III-104, Table 3.14-D
 Cylinder Thickness (gage) = 16
 Cylinder Height (in) = 13

Determine Tailwater conditions to size outlet apron

Use Normal Depth Procedure (Manning's Eqn.) Ref 2, II-7

$$A \cdot R^{2/3} = Q \cdot n / 1.49 s^{0.5} \quad \text{Area (A)} = bd + z(d^2) \quad Z_{av} = A \cdot R^{2/3}$$

$$Z_{req} = Q \cdot n / 1.49 s^{0.5} \quad R = \text{Area} / (b + 2d((z^2 + 1)^{0.5}))$$

n = 0.069 6-inch diameter Rip Rap, Lined Channel
 Vp (ft/sec) = 9 Permissible Velocity for lining
 Side Slope (z) = 5 enter X for X:1
 s (ft/ft) = 0.02 Outlet Slope (estimated)
 Bottom Width (ft) = 3 3 * Barrel Diameter
 Q_B (cfs) = 0.7 Peak Flow out of the barrel 10-yr Hydrograph

Q (cfs)	Z _{req}	Flow Depth d (ft)	A (sf)	R (ft)	Z _{av}	V (ft/sec)
0.7	0.24	0.20	0.8	0.16	0.24	0.9

Flow Depth = Tailwater, d (ft) = 0.20 0.5 * Barrel Diameter (ft) = 0.50 Ref 1, 8.06.3

Minimum Tailwater Conditions: d < 0.5 * Diameter of Outlet Pipe

Maximum Tailwater Conditions: d > 0.5 * Diameter of Outlet Pipe

Since the Tailwater is less than half of the diameter of the outlet, use Minimum Tailwater conditions.

Barrel Diameter (ft)	Entrance (ft)	Length (ft)	Outlet Width (ft)	Median Rip Rap Size d ₅₀	Selected Rip Rap Size (in)
1	3	8	9	0.4	Class A

Conclusion

The temporary basin can contain the 25-yr storm.

HDR Computation

Project:	Charah Colon Mine	Computed:	PAW	Date:	3/4/15
Subject:	Permit Application	Checked:	MDP	Date:	3/6/15
Task:	Riser Pipe Perforations/Skimmer Flow	Sheet:	1	Of:	2

Diameter of Riser (in) = 24
 Circumference of Riser (in) = 75.4
 Height of Riser from bottom of barrel (in) = 64 From Hydrograph
 Vertical spacing between holes (in) = 0 center to center
 Water Stage increment (ft) 0.05

Orifice Equation

$Q = C_d * A * (2 * g * h)^{0.5}$ Ref 1, p III-11
 Q = cfs, discharge
 $C_d = 0.6$ coefficient of discharge
 A = sf, cross sectional area
 $g = 32.2$ ft/sec², gravity
 h = ft, driving head measured from the center of the pipe

Row	Perforations					Skimmer	# of skimmers
	1	2	3	4	5	1	
Holes per row	0	0	0	0	0		
Hole Diameter (in)	0.75	0.75	0.75	0.75	0.75		
Spacing edge to edge (in)							
Inlet Area (sf)	0.000	0.000	0.000	0.000	0.000		
Hole Stage (in)	0.50	0.50	0.50	0.50	0.50		
Hole Stage (ft)	0.04	0.04	0.04	0.04	0.04		

Water Stage (ft)	Flow (cfs)	Flow (cfs)	Flow (cfs)	Flow (cfs)	Flow (cfs)	Flow (cfs)	Total Flow (cfs)
0.00	0.00	0.00	0.00			0.00	0.00
0.04	0.00	0.00	0.00			0.00	0.00
0.09	0.00	0.00	0.00			0.00	0.00
0.14	0.00	0.00	0.00			0.00	0.00
0.19	0.00	0.00	0.00			0.00	0.00
0.24	0.00	0.00	0.00			0.00	0.00
0.29	0.00	0.00	0.00			0.00	0.00
0.34	0.00	0.00	0.00			0.21	0.21
0.39	0.00	0.00	0.00			0.21	0.21
0.44	0.00	0.00	0.00			0.21	0.21
0.49	0.00	0.00	0.00			0.21	0.21
0.54	0.00	0.00	0.00			0.21	0.21
0.59	0.00	0.00	0.00			0.21	0.21
0.64	0.00	0.00	0.00			0.21	0.21
0.69	0.00	0.00	0.00			0.21	0.21
0.74	0.00	0.00	0.00			0.21	0.21
0.79	0.00	0.00	0.00			0.21	0.21
0.84	0.00	0.00	0.00			0.21	0.21
0.89	0.00	0.00	0.00			0.21	0.21
0.94	0.00	0.00	0.00			0.21	0.21
0.99	0.00	0.00	0.00			0.21	0.21
1.04	0.00	0.00	0.00			0.21	0.21
1.09	0.00	0.00	0.00			0.21	0.21
1.14	0.00	0.00	0.00			0.21	0.21
1.19	0.00	0.00	0.00			0.21	0.21
1.24	0.00	0.00	0.00			0.21	0.21
1.29	0.00	0.00	0.00			0.21	0.21
1.34	0.00	0.00	0.00			0.21	0.21
1.39	0.00	0.00	0.00			0.21	0.21
1.44	0.00	0.00	0.00			0.21	0.21
1.49	0.00	0.00	0.00			0.21	0.21
1.54	0.00	0.00	0.00			0.21	0.21
1.59	0.00	0.00	0.00			0.21	0.21

HDR Computation

Project:	Charah Colon Mine	Computed:	PAW	Date:	3/4/15
Subject:	Permit Application	Checked:	MDP	Date:	3/6/15
Task:	Riser Pipe Perforations/Skimmer Flow	Sheet:	2	Of:	2

1.64	0.00	0.00	0.00	0.21	0.21
1.69	0.00	0.00	0.00	0.21	0.21
1.74	0.00	0.00	0.00	0.21	0.21
1.79	0.00	0.00	0.00	0.21	0.21
1.84	0.00	0.00	0.00	0.21	0.21
1.89	0.00	0.00	0.00	0.21	0.21
1.94	0.00	0.00	0.00	0.21	0.21
1.99	0.00	0.00	0.00	0.21	0.21
2.04	0.00	0.00	0.00	0.21	0.21
2.09	0.00	0.00	0.00	0.21	0.21
2.14	0.00	0.00	0.00	0.21	0.21
2.19	0.00	0.00	0.00	0.21	0.21
2.24	0.00	0.00	0.00	0.21	0.21
2.29	0.00	0.00	0.00	0.21	0.21
2.34	0.00	0.00	0.00	0.21	0.21
2.39	0.00	0.00	0.00	0.21	0.21
2.44	0.00	0.00	0.00	0.21	0.21
2.49	0.00	0.00	0.00	0.21	0.21
2.54	0.00	0.00	0.00	0.21	0.21
2.59	0.00	0.00	0.00	0.21	0.21
2.64	0.00	0.00	0.00	0.21	0.21
2.69	0.00	0.00	0.00	0.21	0.21
2.74	0.00	0.00	0.00	0.21	0.21
2.79	0.00	0.00	0.00	0.21	0.21
2.84	0.00	0.00	0.00	0.21	0.21
2.89	0.00	0.00	0.00	0.21	0.21
2.94	0.00	0.00	0.00	0.21	0.21
2.99	0.00	0.00	0.00	0.21	0.21
3.04	0.00	0.00	0.00	0.21	0.21
3.09	0.00	0.00	0.00	0.21	0.21
3.14	0.00	0.00	0.00	0.21	0.21
3.19	0.00	0.00	0.00	0.21	0.21
3.24	0.00	0.00	0.00	0.21	0.21
3.29	0.00	0.00	0.00	0.21	0.21
3.34	0.00	0.00	0.00	0.21	0.21
3.39	0.00	0.00	0.00	0.21	0.21
3.44	0.00	0.00	0.00	0.21	0.21
3.49	0.00	0.00	0.00	0.21	0.21
3.54	0.00	0.00	0.00	0.21	0.21
3.59	0.00	0.00	0.00	0.21	0.21
3.64	0.00	0.00	0.00	0.21	0.21
3.69	0.00	0.00	0.00	0.21	0.21
3.74	0.00	0.00	0.00	0.21	0.21
3.79	0.00	0.00	0.00	0.21	0.21
3.84	0.00	0.00	0.00	0.21	0.21
3.89	0.00	0.00	0.00	0.21	0.21
3.94	0.00	0.00	0.00	0.21	0.21
3.99	0.00	0.00	0.00	0.21	0.21

Sediment Basin # 4 Colon

Qp = 77.74 cfs
 Tp = 28.73 minutes
 dT = Max of 2 minutes
 or 1.0% of increment to peak

Phase 1
 10 - year Storm Event

b = 1.2
 K_s = 25,208

Number of Riser/Barrel Assemblies = 1
 Diameter of Barrel = 12 (in)
 Height of Riser above barrel = 4.3 (ft)
 Height of Riser from bottom of barrel = 5.3 (ft) elevation 266.30
 Emergency Spillway = 6.0 (ft) elevation 267.00
 Total Height of Dam = 6.6 (ft) elevation 267.60
 Length of Emergency Spillway = 20 (ft)
 Diameter of Riser = 24 (in)
 Permanent Pond Stage = 0 (ft) elevation 261.0

4.0E-03 Settling Velocity of design particle (fps)
 2 Effective number of cells (2 is construction site #)
 100% Minimum Settling Efficiency
 5.4 ft Maximum Stage 266.39 msl elevation
 0.7 cfs Peak outflow
 0.7 cfs Peak Riser/Barrel outflow
 0.0 cfs Peak Weir flow

Notes:

1. Length of emergency spillway is the bottom width of the emergency spillway.
2. Settling efficiency neglects permanent pond volume

TIME	INFLOW	STORAGE	STAGE	Skimmer	RISER	WEIR	BARREL	TOTAL	Bound	Estimated	Settling
(min)	[cfs]	[cu ft]	[ft]	Flow [cfs]	CAPACIT	FLOW	CAPACITY	OUTFLOW	Discharge	Surface	Efficiency
					Y [cfs]	[cfs]	[cfs]	[cfs]	[cfs]	Area (sf)	[%]
0	0.0	0	0.0	0.00	0.00	0.00	0.00	0.00	0.00	-	N/A
2	0.9	0	0.0	0.00	0.00	0.00	0.00	0.00	0.00	-	N/A
4	3.7	111	0.0	0.00	0.00	0.00	0.00	0.00	28.66	13,029	N/A
6	8.1	550	0.0	0.00	0.00	0.00	0.00	0.00	36.56	16,618	N/A
8	13.9	1,519	0.1	0.00	0.00	0.00	0.00	0.00	42.66	19,393	N/A
10	21.0	3,192	0.2	0.00	0.00	0.00	0.00	0.00	47.77	21,712	N/A
12	28.9	5,714	0.3	0.00	0.00	0.00	0.00	0.00	52.19	23,722	N/A
14	37.3	9,185	0.4	0.21	0.21	0.00	0.21	0.21	56.10	25,498	100%
16	45.8	13,638	0.6	0.21	0.21	0.00	0.21	0.21	59.57	27,078	100%
18	53.9	19,106	0.8	0.21	0.21	0.00	0.21	0.21	62.71	28,502	100%
20	61.3	25,551	1.0	0.21	0.21	0.00	0.21	0.21	65.54	29,790	100%
22	67.7	32,885	1.3	0.21	0.21	0.00	0.21	0.21	68.10	30,956	100%
24	72.7	40,981	1.5	0.21	0.21	0.00	0.21	0.21	70.42	32,010	100%
26	76.0	49,674	1.8	0.21	0.21	0.00	0.21	0.21	72.51	32,960	100%
28	77.6	58,771	2.0	0.21	0.21	0.00	0.21	0.21	74.39	33,814	100%
30	77.4	68,060	2.3	0.21	0.21	0.00	0.21	0.21	76.07	34,577	100%
32	75.3	77,318	2.6	0.21	0.21	0.00	0.21	0.21	77.56	35,254	100%
34	71.5	86,326	2.8	0.21	0.21	0.00	0.21	0.21	78.87	35,850	100%
36	66.2	94,876	3.1	0.21	0.21	0.00	0.21	0.21	80.01	36,368	100%
38	60.4	102,791	3.3	0.21	0.21	0.00	0.21	0.21	80.99	36,814	100%
40	55.2	110,020	3.5	0.21	0.21	0.00	0.21	0.21	81.83	37,197	100%
42	50.4	116,620	3.7	0.21	0.21	0.00	0.21	0.21	82.56	37,528	100%
44	46.1	122,648	3.8	0.21	0.21	0.00	0.21	0.21	83.20	37,816	100%
46	42.1	128,151	4.0	0.21	0.21	0.00	0.21	0.21	83.75	38,070	100%
48	38.4	133,177	4.1	0.21	0.21	0.00	0.21	0.21	84.24	38,293	100%
50	35.1	137,765	4.2	0.21	0.21	0.00	0.21	0.21	84.68	38,491	100%
52	32.1	141,954	4.3	0.21	0.21	0.00	0.21	0.21	85.07	38,666	100%
54	29.3	145,778	4.4	0.21	0.21	0.00	0.21	0.21	85.41	38,823	100%
56	26.8	149,269	4.5	0.21	0.21	0.00	0.21	0.21	85.72	38,963	100%
58	24.5	152,456	4.6	0.21	0.21	0.00	0.21	0.21	85.99	39,088	100%
60	22.3	155,365	4.7	0.21	0.21	0.00	0.21	0.21	86.24	39,201	100%
62	20.4	158,020	4.7	0.21	0.21	0.00	0.21	0.21	86.46	39,302	100%
64	18.6	160,444	4.8	0.21	0.21	0.00	0.21	0.21	86.66	39,393	100%
66	17.0	162,655	4.9	0.21	0.21	0.00	0.21	0.21	86.85	39,475	100%
68	15.6	164,673	4.9	0.21	0.21	0.00	0.21	0.21	87.01	39,549	100%
70	14.2	166,514	5.0	0.21	0.21	0.00	0.21	0.21	87.16	39,616	100%
72	13.0	168,193	5.0	0.21	0.21	0.00	0.21	0.21	87.29	39,677	100%
74	11.9	169,725	5.0	0.21	0.21	0.00	0.21	0.21	87.41	39,731	100%
76	10.8	171,122	5.1	0.21	0.21	0.00	0.21	0.21	87.52	39,781	100%
78	9.9	172,396	5.1	0.21	0.21	0.00	0.21	0.21	87.62	39,826	100%
80	9.0	173,558	5.1	0.21	0.21	0.00	0.21	0.21	87.71	39,867	100%
82	8.3	174,617	5.2	0.21	0.21	0.00	0.21	0.21	87.79	39,904	100%

84	7.5	175,582	5.2	0.21	0.21	0.00	0.21	0.21	87.86	39,937	100%
86	6.9	176,461	5.2	0.21	0.21	0.00	0.21	0.21	87.93	39,967	100%
88	6.3	177,262	5.2	0.21	0.21	0.00	0.21	0.21	87.99	39,995	100%
90	5.7	177,992	5.2	0.21	0.21	0.00	0.21	0.21	88.04	40,020	100%
92	5.3	178,656	5.3	0.21	0.21	0.00	0.21	0.21	88.09	40,043	100%
94	4.8	179,260	5.3	0.21	0.21	0.00	0.21	0.21	88.14	40,063	100%
96	4.4	179,810	5.3	0.21	0.21	0.00	0.21	0.21	88.18	40,082	100%
98	4.0	180,311	5.3	0.21	0.22	0.00	8.27	0.22	88.22	40,099	100%
100	3.7	180,765	5.3	0.21	0.25	0.00	8.28	0.25	88.25	40,114	100%
102	3.3	181,174	5.3	0.21	0.29	0.00	8.29	0.29	88.28	40,128	100%
104	3.1	181,539	5.3	0.21	0.34	0.00	8.30	0.34	88.31	40,140	100%
106	2.8	181,864	5.3	0.21	0.39	0.00	8.31	0.39	88.33	40,151	100%
108	2.5	182,152	5.3	0.21	0.44	0.00	8.31	0.44	88.35	40,161	100%
110	2.3	182,405	5.4	0.21	0.48	0.00	8.32	0.48	88.37	40,169	100%
112	2.1	182,626	5.4	0.21	0.52	0.00	8.32	0.52	88.39	40,177	100%
114	1.9	182,818	5.4	0.21	0.56	0.00	8.33	0.56	88.40	40,183	100%
116	1.8	182,983	5.4	0.21	0.59	0.00	8.33	0.59	88.41	40,189	100%
118	1.6	183,125	5.4	0.21	0.62	0.00	8.33	0.62	88.43	40,193	100%
120	1.5	183,244	5.4	0.21	0.65	0.00	8.34	0.65	88.43	40,197	100%
122	1.4	183,343	5.4	0.21	0.67	0.00	8.34	0.67	88.44	40,201	100%
124	1.2	183,425	5.4	0.21	0.69	0.00	8.34	0.69	88.45	40,203	100%
126	1.1	183,491	5.4	0.21	0.70	0.00	8.34	0.70	88.45	40,205	100%
128	1.0	183,541	5.4	0.21	0.71	0.00	8.34	0.71	88.46	40,207	100%
130	0.9	183,579	5.4	0.21	0.72	0.00	8.34	0.72	88.46	40,208	100%
132	0.9	183,605	5.4	0.21	0.73	0.00	8.35	0.73	88.46	40,209	100%
134	0.8	183,621	5.4	0.21	0.73	0.00	8.35	0.73	88.46	40,210	100%
136	0.7	183,627	5.4	0.21	0.73	0.00	8.35	0.73	88.46	40,210	100%
138	0.7	183,625	5.4	0.21	0.73	0.00	8.35	0.73	88.46	40,210	100%
140	0.6	183,616	5.4	0.21	0.73	0.00	8.35	0.73	88.46	40,210	100%
142	0.5	183,600	5.4	0.21	0.73	0.00	8.35	0.73	88.46	40,209	100%
144	0.5	183,578	5.4	0.21	0.72	0.00	8.34	0.72	88.46	40,208	100%
146	0.5	183,552	5.4	0.21	0.72	0.00	8.34	0.72	88.46	40,207	100%
148	0.4	183,520	5.4	0.21	0.71	0.00	8.34	0.71	88.45	40,206	100%
150	0.4	183,485	5.4	0.21	0.70	0.00	8.34	0.70	88.45	40,205	100%
152	0.3	183,447	5.4	0.21	0.69	0.00	8.34	0.69	88.45	40,204	100%
154	0.3	183,405	5.4	0.21	0.68	0.00	8.34	0.68	88.45	40,203	100%
156	0.3	183,361	5.4	0.21	0.67	0.00	8.34	0.67	88.44	40,201	100%
158	0.3	183,315	5.4	0.21	0.66	0.00	8.34	0.66	88.44	40,200	100%
160	0.2	183,267	5.4	0.21	0.65	0.00	8.34	0.65	88.44	40,198	100%
162	0.2	183,217	5.4	0.21	0.64	0.00	8.34	0.64	88.43	40,196	100%
164	0.2	183,167	5.4	0.21	0.63	0.00	8.34	0.63	88.43	40,195	100%
166	0.2	183,115	5.4	0.21	0.62	0.00	8.33	0.62	88.42	40,193	100%
168	0.2	183,062	5.4	0.21	0.61	0.00	8.33	0.61	88.42	40,191	100%
170	0.2	183,009	5.4	0.21	0.60	0.00	8.33	0.60	88.42	40,189	100%
172	0.1	182,956	5.4	0.21	0.59	0.00	8.33	0.59	88.41	40,188	100%
174	0.1	182,902	5.4	0.21	0.58	0.00	8.33	0.58	88.41	40,186	100%
176	0.1	182,848	5.4	0.21	0.57	0.00	8.33	0.57	88.40	40,184	100%
178	0.1	182,794	5.4	0.21	0.56	0.00	8.33	0.56	88.40	40,182	100%
180	0.1	182,740	5.4	0.21	0.55	0.00	8.33	0.55	88.40	40,180	100%
182	0.1	182,686	5.4	0.21	0.54	0.00	8.33	0.54	88.39	40,179	100%
184	0.1	182,633	5.4	0.21	0.53	0.00	8.32	0.53	88.39	40,177	100%
186	0.1	182,579	5.4	0.21	0.52	0.00	8.32	0.52	88.39	40,175	100%
188	0.1	182,526	5.4	0.21	0.51	0.00	8.32	0.51	88.38	40,173	100%
190	0.1	182,474	5.4	0.21	0.50	0.00	8.32	0.50	88.38	40,172	100%
192	0.1	182,422	5.4	0.21	0.49	0.00	8.32	0.49	88.37	40,170	100%
194	0.1	182,370	5.4	0.21	0.48	0.00	8.32	0.48	88.37	40,168	100%
196	0.0	182,319	5.4	0.21	0.47	0.00	8.32	0.47	88.37	40,166	100%
198	0.0	182,269	5.4	0.21	0.46	0.00	8.32	0.46	88.36	40,165	100%
200	0.0	182,219	5.4	0.21	0.45	0.00	8.32	0.45	88.36	40,163	100%
202	0.0	182,170	5.3	0.21	0.44	0.00	8.31	0.44	88.35	40,161	100%
204	0.0	182,121	5.3	0.21	0.43	0.00	8.31	0.43	88.35	40,160	100%
206	0.0	182,073	5.3	0.21	0.42	0.00	8.31	0.42	88.35	40,158	100%

**Sediment Basin #4 Colon Mine Phase 1 Hydrograph
10-Yr Storm**

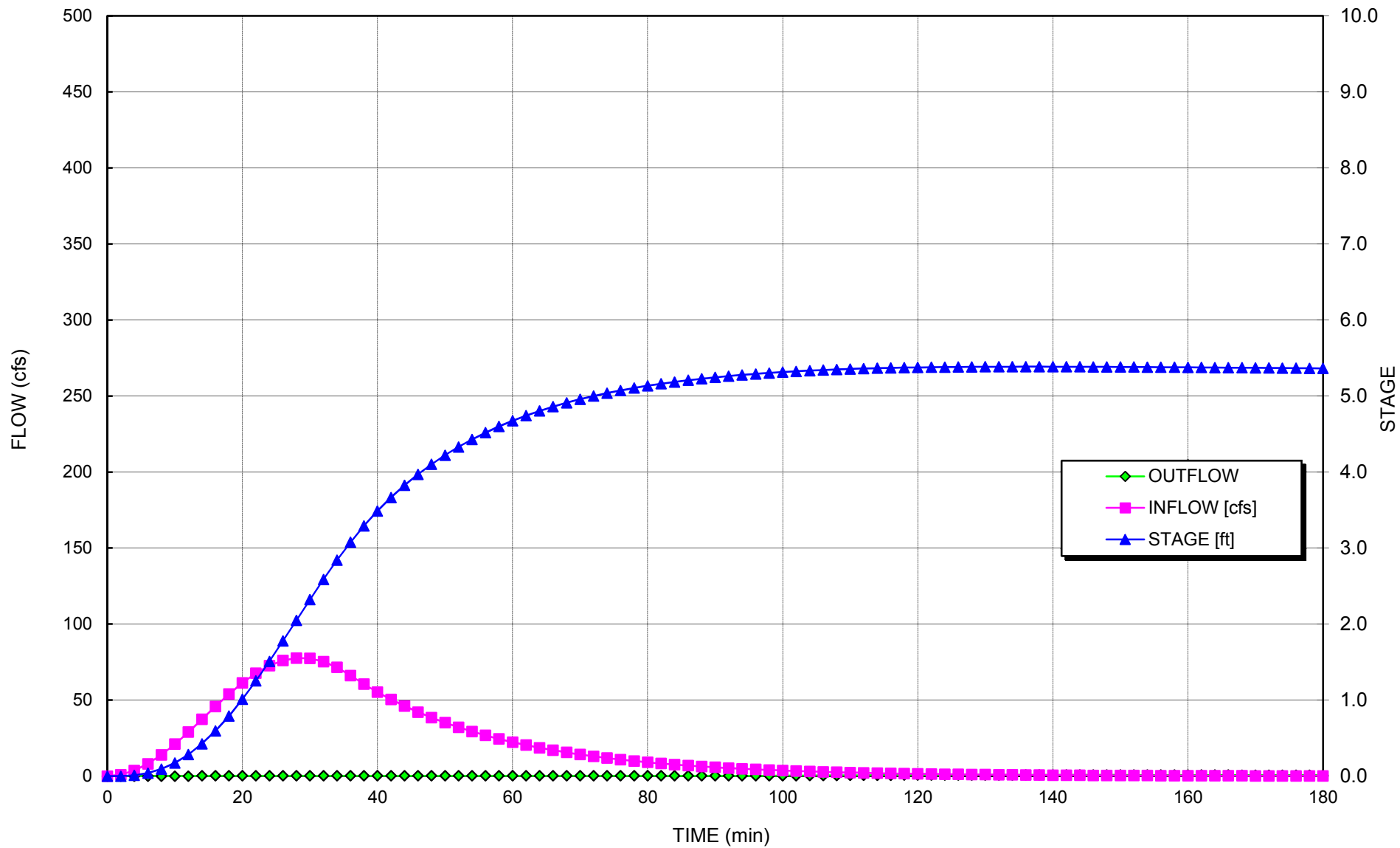

This page intentionally left blank.

Sediment Basin # 4 Colon

Qp = 95.13 cfs
 Tp = 29.09 minutes
 dT = Max of 2 minutes
 or 1.0% of increment to peak

Phase 1
 25 - year Storm Event

b = 1.2
 K_s = 25,208

Number of Riser/Barrel Assemblies = 1
 Diameter of Barrel = 12 (in)
 Height of Riser above barrel = 4.3 (ft)
 Height of Riser from bottom of barrel = 5.3 (ft) elevation 266.30
 Emergency Spillway = 6 (ft) elevation 267.00
 Total Height of Dam = 6.6 (ft) elevation 267.60
 Length of Emergency Spillway = 20 (ft)
 Diameter of Riser = 24 (in)
 Permanent Pond Stage = 0 (ft) elevation 261.0

4.0E-03 Settling Velocity of design particle (fps)
 2 Effective number of cells (2 is construction site #)
 99% Minimum Settling Efficiency
 6.0 ft Maximum Stage 266.95 msl elevation
 8.8 cfs Peak outflow
 8.8 cfs Peak Riser/Barrel outflow
 0.0 cfs Peak Weir flow

Notes:

1. Length of emergency spillway is the bottom width of the emergency spillway.
2. Settling efficiency neglects permanent pond volume

TIME (min)	INFLOW [cfs]	STORAGE [cu ft]	STAGE [ft]	Skimmer Flow [cfs]	RISER CAPACIT Y [cfs]	WEIR FLOW [cfs]	BARREL CAPACITY [cfs]	TOTAL OUTFLOW [cfs]	Bound Discharge [cfs]	Estimated Surface Area (sf)	Settling Efficiency [%]
0	0.0	0	0.0	0.00	0.00	0.00	0.00	0.00	0.00	-	N/A
2	1.1	0	0.0	0.00	0.00	0.00	0.00	0.00	0.00	-	N/A
4	4.4	133	0.0	0.00	0.00	0.00	0.00	0.00	29.45	13,384	N/A
6	9.6	657	0.0	0.00	0.00	0.00	0.00	0.00	37.56	17,072	N/A
8	16.7	1,813	0.1	0.00	0.00	0.00	0.00	0.00	43.83	19,923	N/A
10	25.1	3,814	0.2	0.00	0.00	0.00	0.00	0.00	49.08	22,308	N/A
12	34.6	6,830	0.3	0.00	0.00	0.00	0.00	0.00	53.62	24,375	N/A
14	44.8	10,988	0.5	0.21	0.21	0.00	0.21	0.21	57.65	26,203	100%
16	55.0	16,333	0.7	0.21	0.21	0.00	0.21	0.21	61.23	27,831	100%
18	64.9	22,907	0.9	0.21	0.21	0.00	0.21	0.21	64.46	29,300	100%
20	74.0	30,669	1.2	0.21	0.21	0.00	0.21	0.21	67.38	30,629	100%
22	81.8	39,521	1.5	0.21	0.21	0.00	0.21	0.21	70.03	31,833	100%
24	88.1	49,317	1.8	0.21	0.21	0.00	0.21	0.21	72.43	32,924	100%
26	92.5	59,865	2.1	0.21	0.21	0.00	0.21	0.21	74.60	33,909	100%
28	94.8	70,939	2.4	0.21	0.21	0.00	0.21	0.21	76.55	34,795	100%
30	94.9	82,289	2.7	0.21	0.21	0.00	0.21	0.21	78.30	35,589	100%
32	92.8	93,652	3.0	0.21	0.21	0.00	0.21	0.21	79.85	36,296	100%
34	88.6	104,763	3.3	0.21	0.21	0.00	0.21	0.21	81.23	36,921	100%
36	82.5	115,371	3.6	0.21	0.21	0.00	0.21	0.21	82.43	37,466	100%
38	75.6	125,246	3.9	0.21	0.21	0.00	0.21	0.21	83.46	37,937	100%
40	69.1	134,290	4.1	0.21	0.21	0.00	0.21	0.21	84.35	38,341	100%
42	63.2	142,559	4.3	0.21	0.21	0.00	0.21	0.21	85.12	38,691	100%
44	57.8	150,118	4.5	0.21	0.21	0.00	0.21	0.21	85.79	38,997	100%
46	52.9	157,029	4.7	0.21	0.21	0.00	0.21	0.21	86.38	39,264	100%
48	48.3	163,348	4.9	0.21	0.21	0.00	0.21	0.21	86.90	39,501	100%
50	44.2	169,123	5.0	0.21	0.21	0.00	0.21	0.21	87.36	39,710	100%
52	40.4	174,403	5.2	0.21	0.21	0.00	0.21	0.21	87.77	39,896	100%
54	37.0	179,229	5.3	0.21	0.21	0.00	0.21	0.21	88.14	40,062	100%
56	33.8	183,641	5.4	0.21	0.74	0.00	8.35	0.74	88.46	40,210	100%
58	30.9	187,610	5.5	0.21	1.86	0.00	8.43	1.86	88.75	40,341	100%
60	28.3	191,098	5.6	0.21	3.14	0.00	8.50	3.14	89.00	40,455	100%
62	25.9	194,115	5.6	0.21	4.42	0.00	8.56	4.42	89.21	40,551	100%
64	23.7	196,688	5.7	0.21	5.63	0.00	8.62	5.63	89.39	40,632	100%
66	21.6	198,850	5.8	0.21	6.72	0.00	8.66	6.72	89.54	40,700	99%
68	19.8	200,639	5.8	0.21	7.67	0.00	8.70	7.67	89.66	40,755	99%
70	18.1	202,091	5.8	0.21	8.48	0.00	8.73	8.48	89.76	40,800	99%
72	16.5	203,245	5.9	0.21	9.13	0.00	8.75	8.75	89.84	40,836	99%
74	15.1	204,180	5.9	0.21	9.67	0.00	8.77	8.77	89.90	40,864	99%
76	13.8	204,944	5.9	0.21	10.13	0.00	8.78	8.78	89.95	40,887	99%
78	12.7	205,550	5.9	0.21	10.49	0.00	8.80	8.80	89.99	40,906	99%
80	11.6	206,013	5.9	0.21	10.77	0.00	8.80	8.80	90.02	40,920	99%
82	10.6	206,345	5.9	0.21	10.97	0.00	8.81	8.81	90.05	40,930	99%

84	9.7	206,557	6.0	0.21	11.10	0.00	8.82	8.82	90.06	40,936	99%
86	8.9	206,661	6.0	0.21	11.16	0.00	8.82	8.82	90.07	40,939	99%
88	8.1	206,665	6.0	0.21	11.17	0.00	8.82	8.82	90.07	40,939	99%
90	7.4	206,578	6.0	0.21	11.11	0.00	8.82	8.82	90.06	40,937	99%
92	6.8	206,408	5.9	0.21	11.01	0.00	8.81	8.81	90.05	40,932	99%
94	6.2	206,163	5.9	0.21	10.86	0.00	8.81	8.81	90.03	40,924	99%
96	5.7	205,849	5.9	0.21	10.67	0.00	8.80	8.80	90.01	40,915	99%
98	5.2	205,472	5.9	0.21	10.44	0.00	8.79	8.79	89.99	40,903	99%
100	4.7	205,038	5.9	0.21	10.18	0.00	8.79	8.79	89.96	40,890	99%
102	4.3	204,552	5.9	0.21	9.89	0.00	8.78	8.78	89.93	40,875	99%
104	4.0	204,019	5.9	0.21	9.58	0.00	8.76	8.76	89.89	40,859	99%
106	3.6	203,442	5.9	0.21	9.25	0.00	8.75	8.75	89.85	40,842	99%
108	3.3	202,826	5.9	0.21	8.89	0.00	8.74	8.74	89.81	40,823	99%
110	3.0	202,175	5.8	0.21	8.52	0.00	8.73	8.52	89.77	40,803	99%
112	2.8	201,515	5.8	0.21	8.16	0.00	8.71	8.16	89.72	40,782	99%
114	2.5	200,869	5.8	0.21	7.80	0.00	8.70	7.80	89.68	40,763	99%
116	2.3	200,237	5.8	0.21	7.46	0.00	8.69	7.46	89.63	40,743	99%
118	2.1	199,620	5.8	0.21	7.13	0.00	8.68	7.13	89.59	40,724	99%
120	1.9	199,019	5.8	0.21	6.81	0.00	8.66	6.81	89.55	40,705	99%
122	1.8	198,434	5.8	0.21	6.51	0.00	8.65	6.51	89.51	40,687	99%
124	1.6	197,865	5.7	0.21	6.22	0.00	8.64	6.22	89.47	40,669	99%
126	1.5	197,313	5.7	0.21	5.94	0.00	8.63	5.94	89.43	40,652	100%
128	1.4	196,778	5.7	0.21	5.68	0.00	8.62	5.68	89.40	40,635	100%
130	1.2	196,259	5.7	0.21	5.43	0.00	8.61	5.43	89.36	40,619	100%
132	1.1	195,757	5.7	0.21	5.18	0.00	8.60	5.18	89.33	40,603	100%
134	1.0	195,271	5.7	0.21	4.95	0.00	8.59	4.95	89.29	40,588	100%
136	0.9	194,800	5.7	0.21	4.74	0.00	8.58	4.74	89.26	40,573	100%
138	0.9	194,346	5.7	0.21	4.53	0.00	8.57	4.53	89.23	40,558	100%
140	0.8	193,906	5.6	0.21	4.33	0.00	8.56	4.33	89.20	40,544	100%
142	0.7	193,482	5.6	0.21	4.14	0.00	8.55	4.14	89.17	40,531	100%
144	0.7	193,072	5.6	0.21	3.96	0.00	8.54	3.96	89.14	40,518	100%
146	0.6	192,676	5.6	0.21	3.79	0.00	8.54	3.79	89.11	40,505	100%
148	0.6	192,294	5.6	0.21	3.63	0.00	8.53	3.63	89.08	40,493	100%
150	0.5	191,925	5.6	0.21	3.47	0.00	8.52	3.47	89.06	40,481	100%
152	0.5	191,569	5.6	0.21	3.33	0.00	8.51	3.33	89.03	40,470	100%
154	0.4	191,225	5.6	0.21	3.19	0.00	8.51	3.19	89.01	40,459	100%
156	0.4	190,893	5.6	0.21	3.06	0.00	8.50	3.06	88.99	40,448	100%
158	0.4	190,573	5.6	0.21	2.93	0.00	8.49	2.93	88.96	40,438	100%
160	0.3	190,264	5.6	0.21	2.81	0.00	8.49	2.81	88.94	40,428	100%
162	0.3	189,966	5.5	0.21	2.70	0.00	8.48	2.70	88.92	40,418	100%
164	0.3	189,678	5.5	0.21	2.59	0.00	8.47	2.59	88.90	40,409	100%
166	0.2	189,400	5.5	0.21	2.48	0.00	8.47	2.48	88.88	40,400	100%
168	0.2	189,131	5.5	0.21	2.39	0.00	8.46	2.39	88.86	40,391	100%
170	0.2	188,872	5.5	0.21	2.29	0.00	8.46	2.29	88.84	40,383	100%
172	0.2	188,622	5.5	0.21	2.20	0.00	8.45	2.20	88.82	40,374	100%
174	0.2	188,380	5.5	0.21	2.12	0.00	8.45	2.12	88.81	40,367	100%
176	0.2	188,146	5.5	0.21	2.04	0.00	8.44	2.04	88.79	40,359	100%
178	0.1	187,921	5.5	0.21	1.96	0.00	8.44	1.96	88.77	40,352	100%
180	0.1	187,703	5.5	0.21	1.89	0.00	8.43	1.89	88.76	40,344	100%
182	0.1	187,492	5.5	0.21	1.82	0.00	8.43	1.82	88.74	40,338	100%
184	0.1	187,288	5.5	0.21	1.75	0.00	8.42	1.75	88.73	40,331	100%
186	0.1	187,091	5.5	0.21	1.69	0.00	8.42	1.69	88.71	40,324	100%
188	0.1	186,901	5.5	0.21	1.63	0.00	8.41	1.63	88.70	40,318	100%
190	0.1	186,716	5.5	0.21	1.57	0.00	8.41	1.57	88.69	40,312	100%
192	0.1	186,538	5.5	0.21	1.52	0.00	8.41	1.52	88.67	40,306	100%
194	0.1	186,365	5.5	0.21	1.46	0.00	8.40	1.46	88.66	40,301	100%
196	0.1	186,198	5.4	0.21	1.41	0.00	8.40	1.41	88.65	40,295	100%
198	0.1	186,037	5.4	0.21	1.37	0.00	8.40	1.37	88.64	40,290	100%
200	0.1	185,880	5.4	0.21	1.32	0.00	8.39	1.32	88.63	40,285	100%
202	0.0	185,728	5.4	0.21	1.28	0.00	8.39	1.28	88.62	40,280	100%
204	0.0	185,581	5.4	0.21	1.23	0.00	8.39	1.23	88.60	40,275	100%
206	0.0	185,438	5.4	0.21	1.19	0.00	8.38	1.19	88.59	40,270	100%

**Sediment Basin #4 Colon Mine Phase 1 Hydrograph
25-Yr Storm**

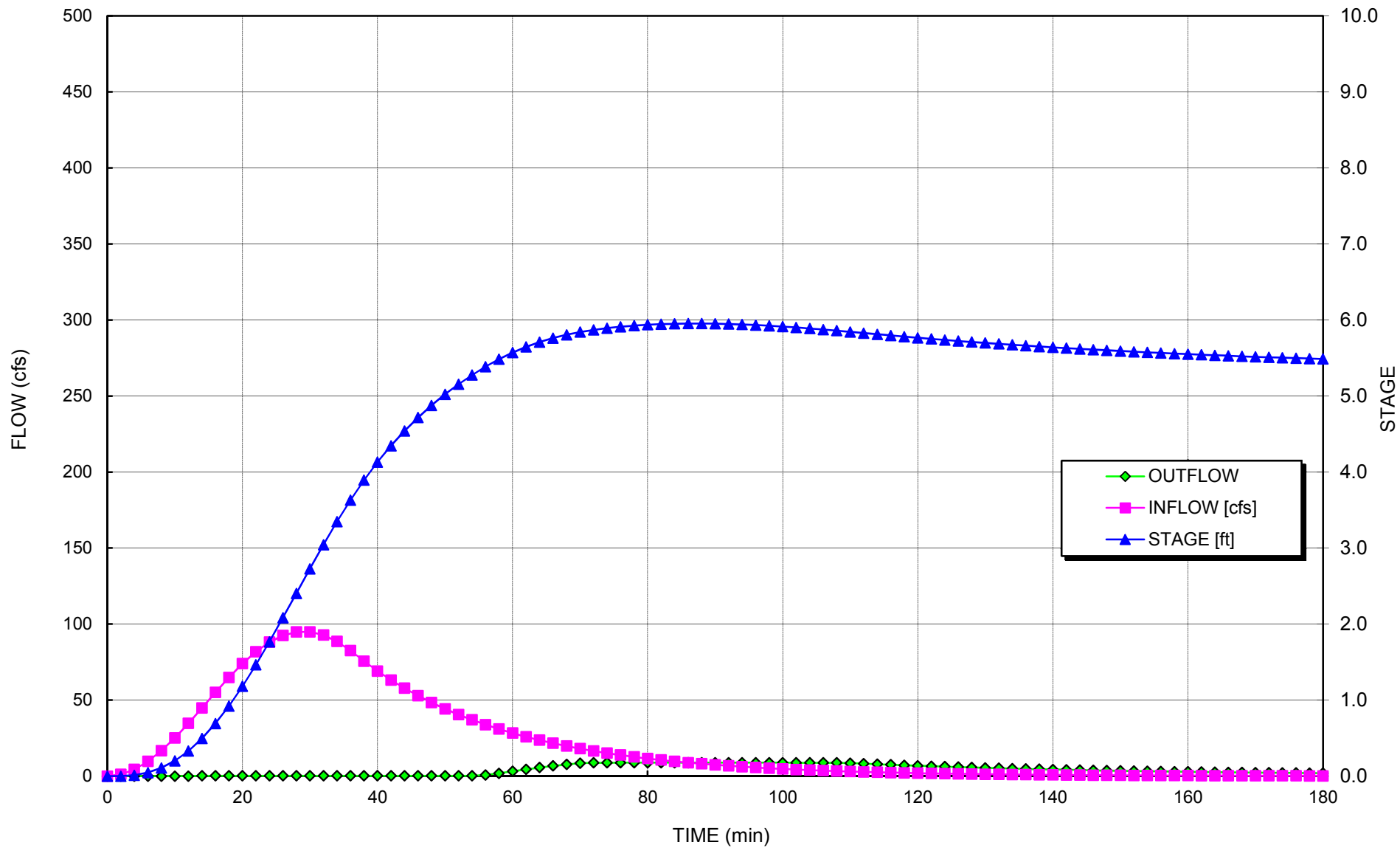

This page intentionally left blank.

Project:	Charah Colon Mine	Computed:	EAW	Date:	1/4/15
Subject:	Permit Application	Checked:	PAW	Date:	1/4/15
Task:	Sediment Basin #5	Sheet:	1	Of:	4

Objective Design the sediment basin to contain the 10-year storm and pass the 100-year storm without over topping the berm.

References

1. NC Erosion and Sediment Control Planning and Design Manual.
2. "Elements of Urban Stormwater Design" by H. Rooney Malcom, P.E.
3. VA Erosion and Sediment Control Handbook
3. NOAA Atlas 14, Volume 2, Version 3

Given

	Phase	1	2	2	2		
	Storm Event (yrs) =	10	10	25	100		
	Total Drainage Area A (ac) =	49.3	42.1	42.1	42.1		
	Disturbed Area (ac) =	49.3	42.1	42.1	42.1		
	Curve Number CN =	89	88	88	88	Hydrographs	
	Rainfall Depth P (in) =	5.28	5.28	6.28	7.88	(24-hr rainfall)	Ref 3
	Peak Flow Q _p (cfs) =	301.78	252.52	310.28	402.08	Hydrographs	

Design Criteria

Required sediment storage	1,800	cf / acre of drainage
Required sediment storage	88,740	cf (based on largest Phase)
Required Surface Area	435	sf/cfs of the 10-yr storm peak flow (based on the largest Phase in cfs)
Required Surface Area (SF)	131,274	of the 10-yr storm peak flow (based on the largest Phase)

Determine Shape of Basin:

Measure the area of the Basin using AutoCADD.

Calculate Volume of the Basin using Truncated Pyramid Method.

Shape factor used in hydrographs basin depth may be greater than indicated below

Elevation (ft)	Depth (ft)	Area (sf)	Volume (cf)	Cumulative Vol (cf)	Cumulative Vol (cy)
255	0	118,763	0	0	0
256	1	124,341	121,541	121,541	4,502
257	2	129,979	127,150	248,691	9,211
258	3	135,678	132,818	381,509	14,130
259	4	141,437	138,548	520,057	19,261
260	5	147,256	144,337	664,393	24,607
261	6	153,136	150,186	814,580	30,170

Design Sediment Depth (ft) = 3

Sediment Storage (cf) = 381,509

Required Sediment Storage Achieved

Design Surface Area Depth (ft) = 3

Surface Area (sf) = 135,678

Required Surface Area Achieved

Project: Charah Colon Mine	Computed: EAW	Date: 1/4/15
Subject: Permit Application	Checked: PAW	Date: 1/4/15
Task: Sediment Basin #5	Sheet: 2	Of: 4

Select Skimmer

A. R. Jarrett Method

$$D = [Q / (2,310 * (H^{0.5}))]^{0.5}$$

D = Diameter of Orifice (inches)
 Q = Dewater Rate (cf/day)
 H = Head on orifice, varies based on skimmer size (ft)

Skimmer Sizes (Inches)	Head (ft)
1.5	0.125
2	0.167
2.5	0.167
3	0.250
4	0.333
5	0.333
6	0.417
8	0.500

Volume to Dewater (cf) =	381,509		
Number of Skimmers	2		
Days to Drain =	5	<i>assumed</i>	
Q each (cf/day) =	38,151		0.44 cfs
Selected Skimmer Size (inches) =	6		
Head on Skimmer (feet) =	0.417		
Diameter of Orifice (inches) =	5.1		

Route the flow through the Basin

Riser is not perforated, but skimmer is attached.

$$S = (1000/CN) - 10$$

$$\text{Runoff Depth } Q^* \text{ (inches)} = (P-0.2S)^2 / (P+0.8S)$$

$$T_p \text{ (min)} = 60.5(Q^*)A/Q_p / 1.39$$

Ref 2, III-4

	1	2	2	2
Storm Event (yrs) =	10	10	25	100
S =	1.24	1.36	1.36	1.36
Runoff Depth Q* (inches) =	4.04	3.94	4.90	6.45
Time to Peak T _p (min) =	28.73	28.56	28.91	29.40

Determine Pond Storage Elevation (Z_{water}):

Pick one point near max expected water surface and the other at the mid depth.

$$Z_1 \text{ (ft)} = 3 \quad S_1 \text{ (cf)} = 381,509$$

$$Z_2 \text{ (ft)} = 6 \quad S_2 \text{ (cf)} = 814,580$$

$$b = \ln(S_2/S_1) / \ln(Z_2/Z_1) = 1.1$$

$$K_S = S_2 / Z_2^b = 114,650$$

Ref 2, III-8

Project: Charah Colon Mine	Computed: EAW	Date: 1/4/15
Subject: Permit Application	Checked: PAW	Date: 1/4/15
Task: Sediment Basin #5	Sheet: 3	Of: 4

Determine Settling Velocity

Conversion Factor = 3.281 ft/sec per m/sec
 Gravitational Acceleration, g (m/s^2) = 9.81
 Specific Gravity of soil (s_s) = 2.6
 Kinematic Viscosity of water (ν) = 1.14E-06 m^2 / sec @ 20°C Ref 2, IV-11
 Diameter of the Design Particle d_{15} = 40.00E-06 m

Design Particle Settling Velocity = $(g / 18) * [(s_s - 1) / \nu] d^2 = 4.02E-03$ ft/sec

Route the Storm through the Basin using the Hydrograph Model

Set Height of Emergency Spillway at (ft) = 6.00 *See Hydrograph*
 Set Top of Dam at (ft) = 7.00

Emergency Spillway

Q_E (cfs) = 100-Yr Storm
 Q_E (cfs) = 2.9
 Cross Section = Trapezoid
 Channel Side Slope (z) = 5 (enter X for X:1)
 n = 0.03 Grass Lined
 V_p (ft/sec) = 5.0 Permissible Velocity for lining Ref 2, II-7
 Allowable Shear Stress (psf) = 2.0 Allowable Shear Stress for lining
 Bottom Width, b (ft) = 20

Calculate Required Depth of Spillway:

Normal-Depth Procedure

$AR^{2/3} = Qn / 1.49s^{0.5}$ $Q = VA$
 $Z_{req} = Qn / 1.49s^{0.5}$ Area (A) = $bd + z(d^2)$
 $Z_{av} = AR^{2/3}$ $R = Area / (b + 2d((z^2 + 1)^{.5}))$
 Avg Shear Stress (T) = $K_b * d * s$ * unit weight of water

Channel Slope ft/ft	Depth, d (ft)	A (sf)	Z_{req}	R	Z_{avail}	V (ft/sec)	T (psf)
0.01	0.18	3.77	0.58	0.17	1.17	1.5	0.1
0.02	0.15	3.03	0.41	0.14	0.82	1.9	0.2

Construct the channel to be : 20 ft, Bottom Width (measured at top of lining)
 1.0 ft, depth (measured at top of lining)
 1% slope

Anti-Seep Collar:

Anti-Seep Collar Size = 2 * Barrel Dia
 Anti-Seep Collar Size (ft) = 4
 Use Anti-Seep Collar Size (ft) = 4 x 4

Project: Charah Colon Mine	Computed: EAW	Date: 1/4/15
Subject: Permit Application	Checked: PAW	Date: 1/4/15
Task: Sediment Basin #5	Sheet: 4	Of: 4

Minimum Concrete Base for Riser:

Diameter of Riser (in) = 48 From Hydrograph
 Avg Density of Concrete (lbs/cf) = 87.6
 Density of Water (lbs/cf) = 62.4
 Riser Displacement (cf) = 66.60 $\text{Pi} * (\text{D}_R/24)^2 * \text{Total Ht of Riser}$
 Convert cf to cy = 27^{-1}
 Min Concrete Needed (cy) = 1.76
 Width & Length (ft) = 5
 Thickness (ft) = 1.9

Anti-Vortex Device:

Diameter of Riser (in) = 48 From Hydrograph
 Cylinder Diameter (in) = 78 Ref 3, III-104, Table 3.14-D
 Cylinder Thickness (gage) = 16
 Cylinder Height (in) = 25

Determine Tailwater conditions to size outlet apron

Use Normal Depth Procedure (Manning's Eqn.) Ref 2, II-7

$A * R^{2/3} = Q * n / 1.49 s^{0.5}$ Area (A) = $bd + z(d^2)$ $Z_{av} = A * R^{2/3}$
 $Z_{req} = Q * n / 1.49 s^{0.5}$ $R = \text{Area} / (b + 2d((z^2 + 1)^{0.5}))$

n = 0.069 6-inch diameter Rip Rap, Lined Channel
 Vp (ft/sec) = 9 Permissible Velocity for lining
 Side Slope (z) = 5 enter X for X:1
 s (ft/ft) = 0.02 Outlet Slope (estimated)
 Bottom Width (ft) = 12 6 * Barrel Diameter
 Q_B (cfs) = 5.1 Peak Flow out of the barrel 25-yr Hydrograph

Q (cfs)	Z _{req}	Flow Depth d (ft)	A (sf)	R (ft)	Z _{av}	V (ft/sec)
5.1	1.66	0.51	7.4	0.43	4.22	0.7

Flow Depth = Tailwater, d (ft) = 0.51 0.5* Barrel Diameter (ft) = 1.00 Ref 1, 8.06.3

Minimum Tailwater Conditions: $d < 0.5 * \text{Diameter of Outlet Pipe}$

Maximum Tailwater Conditions: $d > 0.5 * \text{Diameter of Outlet Pipe}$

Since the Tailwater is less than half of the diameter of the outlet, use Minimum Tailwater conditions.

Barrel Diameter (ft)	Entrance (ft)	Length (ft)	Outlet Width (ft)	Median Rip Rap Size d ₅₀	Selected Rip Rap Size (in)
2	6	10	12	0.3	Class A

Conclusion

The basin can contain the 10-yr storm and pass the 100-yr storm without overtopping the berm.

HDR Computation

Project:	Charah Colon Mine	Computed: PAW	Date: 12/31/14
Subject:	Permit Application	Checked: EAW	Date: 1/2/15
Task:	Riser Pipe Perforations/Skimmer Flow	Sheet 1	Of 2

Diameter of Riser (in) = 48
 Circumference of Riser (in) = 150.8
 Height of Riser from bottom of barrel (in) = 64 From Hydrograph
 Vertical spacing between holes (in) = 0 center to center
 Water Stage increment (ft) 0.05

Orifice Equation

$Q = C_d * A * (2 * g * h)^{0.5}$ Ref 1, p III-11
 Q = cfs, discharge
 $C_d = 0.6$ coefficient of discharge
 A = sf, cross sectional area
 $g = 32.2$ ft/sec², gravity
 h = ft, driving head measured from the center of the pipe

Row	Perforations					Skimmer	# of skimmers
	1	2	3	4	5		
Holes per row	0	0	0	0	0	2	
Hole Diameter (in)	0.75	0.75	0.75	0.75	0.75		
Spacing edge to edge (in)							
Inlet Area (sf)	0.000	0.000	0.000	0.000	0.000		
Hole Stage (in)	0.50	0.50	0.50	0.50	0.50		
Hole Stage (ft)	0.04	0.04	0.04	0.04	0.04		

Water Stage (ft)	Flow (cfs)	Flow (cfs)	Flow (cfs)	Flow (cfs)	Flow (cfs)	Flow (cfs)	Total Flow (cfs)
0.00	0.00	0.00	0.00			0.00	0.00
0.04	0.00	0.00	0.00			0.00	0.00
0.09	0.00	0.00	0.00			0.00	0.00
0.14	0.00	0.00	0.00			0.00	0.00
0.19	0.00	0.00	0.00			0.00	0.00
0.24	0.00	0.00	0.00			0.00	0.00
0.29	0.00	0.00	0.00			0.00	0.00
0.34	0.00	0.00	0.00			0.00	0.00
0.39	0.00	0.00	0.00			0.00	0.00
0.44	0.00	0.00	0.00			0.88	0.88
0.49	0.00	0.00	0.00			0.88	0.88
0.54	0.00	0.00	0.00			0.88	0.88
0.59	0.00	0.00	0.00			0.88	0.88
0.64	0.00	0.00	0.00			0.88	0.88
0.69	0.00	0.00	0.00			0.88	0.88
0.74	0.00	0.00	0.00			0.88	0.88
0.79	0.00	0.00	0.00			0.88	0.88
0.84	0.00	0.00	0.00			0.88	0.88
0.89	0.00	0.00	0.00			0.88	0.88
0.94	0.00	0.00	0.00			0.88	0.88
0.99	0.00	0.00	0.00			0.88	0.88
1.04	0.00	0.00	0.00			0.88	0.88
1.09	0.00	0.00	0.00			0.88	0.88
1.14	0.00	0.00	0.00			0.88	0.88
1.19	0.00	0.00	0.00			0.88	0.88
1.24	0.00	0.00	0.00			0.88	0.88
1.29	0.00	0.00	0.00			0.88	0.88
1.34	0.00	0.00	0.00			0.88	0.88
1.39	0.00	0.00	0.00			0.88	0.88
1.44	0.00	0.00	0.00			0.88	0.88
1.49	0.00	0.00	0.00			0.88	0.88
1.54	0.00	0.00	0.00			0.88	0.88
1.59	0.00	0.00	0.00			0.88	0.88

HDR Computation

Project:	Charah Colon Mine	Computed: PAW	Date: 12/31/14
Subject:	Permit Application	Checked: EAW	Date: 1/2/15
Task:	Riser Pipe Perforations/Skimmer Flow	Sheet 2	Of 2

1.64	0.00	0.00	0.00	0.88	0.88
1.69	0.00	0.00	0.00	0.88	0.88
1.74	0.00	0.00	0.00	0.88	0.88
1.79	0.00	0.00	0.00	0.88	0.88
1.84	0.00	0.00	0.00	0.88	0.88
1.89	0.00	0.00	0.00	0.88	0.88
1.94	0.00	0.00	0.00	0.88	0.88
1.99	0.00	0.00	0.00	0.88	0.88
2.04	0.00	0.00	0.00	0.88	0.88
2.09	0.00	0.00	0.00	0.88	0.88
2.14	0.00	0.00	0.00	0.88	0.88
2.19	0.00	0.00	0.00	0.88	0.88
2.24	0.00	0.00	0.00	0.88	0.88
2.29	0.00	0.00	0.00	0.88	0.88
2.34	0.00	0.00	0.00	0.88	0.88
2.39	0.00	0.00	0.00	0.88	0.88
2.44	0.00	0.00	0.00	0.88	0.88
2.49	0.00	0.00	0.00	0.88	0.88
2.54	0.00	0.00	0.00	0.88	0.88
2.59	0.00	0.00	0.00	0.88	0.88
2.64	0.00	0.00	0.00	0.88	0.88
2.69	0.00	0.00	0.00	0.88	0.88
2.74	0.00	0.00	0.00	0.88	0.88
2.79	0.00	0.00	0.00	0.88	0.88
2.84	0.00	0.00	0.00	0.88	0.88
2.89	0.00	0.00	0.00	0.88	0.88
2.94	0.00	0.00	0.00	0.88	0.88
2.99	0.00	0.00	0.00	0.88	0.88
3.04	0.00	0.00	0.00	0.88	0.88
3.09	0.00	0.00	0.00	0.88	0.88
3.14	0.00	0.00	0.00	0.88	0.88
3.19	0.00	0.00	0.00	0.88	0.88
3.24	0.00	0.00	0.00	0.88	0.88
3.29	0.00	0.00	0.00	0.88	0.88
3.34	0.00	0.00	0.00	0.88	0.88
3.39	0.00	0.00	0.00	0.88	0.88
3.44	0.00	0.00	0.00	0.88	0.88
3.49	0.00	0.00	0.00	0.88	0.88
3.54	0.00	0.00	0.00	0.88	0.88
3.59	0.00	0.00	0.00	0.88	0.88
3.64	0.00	0.00	0.00	0.88	0.88
3.69	0.00	0.00	0.00	0.88	0.88
3.74	0.00	0.00	0.00	0.88	0.88
3.79	0.00	0.00	0.00	0.88	0.88
3.84	0.00	0.00	0.00	0.88	0.88
3.89	0.00	0.00	0.00	0.88	0.88
3.94	0.00	0.00	0.00	0.88	0.88
3.99	0.00	0.00	0.00	0.88	0.88

Sediment Basin # 5 Colon

Qp = 301.78 cfs
 Tp = 28.73 minutes
 dT = Max of 2 minutes
 or 1.0% of increment to peak

Phase 1
10 - year Storm Event

b = 1.1
 K_s = 114,650

Number of Riser/Barrel Assemblies = 2
 Diameter of Barrel = 24 (in)
 Height of Riser above barrel = 3.3 (ft)
 Height of Riser from bottom of barrel = 5.3 (ft) elevation 260.30
 Emergency Spillway = 6.0 (ft) elevation 261.00
 Total Height of Dam = 7.0 (ft) elevation 262.00
 Length of Emergency Spillway = 20 (ft)
 Diameter of Riser = 48 (in)
 Permanent Pond Stage = 0 (ft) elevation 255.0

4.0E-03 Settling Velocity of design particle (fps)
 2 Effective number of cells (2 is construction site #)
 100% Minimum Settling Efficiency
 5.3 ft Maximum Stage 260.29 msl elevation
 1.8 cfs Peak outflow
 1.8 cfs Peak Riser/Barrel outflow
 0.0 cfs Peak Weir flow

Notes:

1. Length of emergency spillway is the bottom width of the emergency spillway.
2. Settling efficiency neglects permanent pond volume

TIME	INFLOW	STORAGE	STAGE	Skimmer	RISER	WEIR	BARREL	TOTAL	Bound	Estimated	Settling
(min)	[cfs]	[cu ft]	[ft]	Flow [cfs]	CAPACIT	FLOW	CAPACITY	OUTFLOW	Discharge	Surface	Efficiency
					Y [cfs]	[cfs]	[cfs]	[cfs]	[cfs]	Area (sf)	[%]
0	0.0	0	0.0	0.00	0.00	0.00	0.00	0.00	0.00	-	N/A
2	3.6	0	0.0	0.00	0.00	0.00	0.00	0.00	0.00	-	N/A
4	14.2	431	0.0	0.00	0.00	0.00	0.00	0.00	170.58	77,537	N/A
6	31.3	2,136	0.0	0.00	0.00	0.00	0.00	0.00	195.81	89,003	N/A
8	54.1	5,895	0.1	0.00	0.00	0.00	0.00	0.00	213.72	97,144	N/A
10	81.6	12,393	0.1	0.00	0.00	0.00	0.00	0.00	227.85	103,570	N/A
12	112.3	22,181	0.2	0.00	0.00	0.00	0.00	0.00	239.58	108,900	N/A
14	144.9	35,658	0.3	0.00	0.00	0.00	0.00	0.00	249.59	113,449	N/A
16	177.7	53,042	0.5	0.88	0.88	0.00	0.88	1.77	258.28	117,400	100%
18	209.3	74,157	0.7	0.88	0.88	0.00	0.88	1.77	265.85	120,840	100%
20	238.1	99,061	0.9	0.88	0.88	0.00	0.88	1.77	272.57	123,895	100%
22	262.7	127,420	1.1	0.88	0.88	0.00	0.88	1.77	278.55	126,613	100%
24	282.0	158,736	1.3	0.88	0.88	0.00	0.88	1.77	283.88	129,034	100%
26	295.1	192,369	1.6	0.88	0.88	0.00	0.88	1.77	288.62	131,190	100%
28	301.3	227,570	1.9	0.88	0.88	0.00	0.88	1.77	292.83	133,104	100%
30	300.3	263,514	2.1	0.88	0.88	0.00	0.88	1.77	296.55	134,798	100%
32	292.2	299,341	2.4	0.88	0.88	0.00	0.88	1.77	299.83	136,287	100%
34	277.4	334,197	2.7	0.88	0.88	0.00	0.88	1.77	302.69	137,587	100%
36	256.9	367,275	2.9	0.88	0.88	0.00	0.88	1.77	305.16	138,711	100%
38	234.7	397,889	3.1	0.88	0.88	0.00	0.88	1.77	307.28	139,672	100%
40	214.4	425,835	3.3	0.88	0.88	0.00	0.88	1.77	309.08	140,492	100%
42	195.8	451,346	3.5	0.88	0.88	0.00	0.88	1.77	310.64	141,198	100%
44	178.9	474,630	3.7	0.88	0.88	0.00	0.88	1.77	311.99	141,812	100%
46	163.4	495,882	3.8	0.88	0.88	0.00	0.88	1.77	313.17	142,348	100%
48	149.3	515,277	3.9	0.88	0.88	0.00	0.88	1.77	314.20	142,820	100%
50	136.3	532,975	4.1	0.88	0.88	0.00	0.88	1.77	315.12	143,236	100%
52	124.5	549,123	4.2	0.88	0.88	0.00	0.88	1.77	315.93	143,605	100%
54	113.8	563,856	4.3	0.88	0.88	0.00	0.88	1.77	316.65	143,933	100%
56	103.9	577,296	4.4	0.88	0.88	0.00	0.88	1.77	317.30	144,226	100%
58	94.9	589,555	4.5	0.88	0.88	0.00	0.88	1.77	317.87	144,487	100%
60	86.7	600,734	4.5	0.88	0.88	0.00	0.88	1.77	318.39	144,722	100%
62	79.2	610,928	4.6	0.88	0.88	0.00	0.88	1.77	318.85	144,932	100%
64	72.4	620,222	4.7	0.88	0.88	0.00	0.88	1.77	319.26	145,120	100%
66	66.1	628,693	4.7	0.88	0.88	0.00	0.88	1.77	319.64	145,290	100%
68	60.4	636,413	4.8	0.88	0.88	0.00	0.88	1.77	319.97	145,443	100%
70	55.2	643,447	4.8	0.88	0.88	0.00	0.88	1.77	320.28	145,581	100%
72	50.4	649,854	4.9	0.88	0.88	0.00	0.88	1.77	320.55	145,705	100%
74	46.0	655,688	4.9	0.88	0.88	0.00	0.88	1.77	320.80	145,818	100%
76	42.0	660,998	5.0	0.88	0.88	0.00	0.88	1.77	321.02	145,919	100%
78	38.4	665,832	5.0	0.88	0.88	0.00	0.88	1.77	321.22	146,011	100%
80	35.1	670,228	5.0	0.88	0.88	0.00	0.88	1.77	321.41	146,094	100%
82	32.0	674,226	5.0	0.88	0.88	0.00	0.88	1.77	321.57	146,169	100%

84	29.3	677,859	5.1	0.88	0.88	0.00	0.88	1.77	321.72	146,236	100%
86	26.7	681,160	5.1	0.88	0.88	0.00	0.88	1.77	321.85	146,298	100%
88	24.4	684,157	5.1	0.88	0.88	0.00	0.88	1.77	321.98	146,353	100%
90	22.3	686,876	5.1	0.88	0.88	0.00	0.88	1.77	322.09	146,403	100%
92	20.4	689,342	5.2	0.88	0.88	0.00	0.88	1.77	322.19	146,448	100%
94	18.6	691,576	5.2	0.88	0.88	0.00	0.88	1.77	322.28	146,489	100%
96	17.0	693,598	5.2	0.88	0.88	0.00	0.88	1.77	322.36	146,526	100%
98	15.5	695,427	5.2	0.88	0.88	0.00	0.88	1.77	322.43	146,559	100%
100	14.2	697,080	5.2	0.88	0.88	0.00	0.88	1.77	322.50	146,589	100%
102	13.0	698,571	5.2	0.88	0.88	0.00	0.88	1.77	322.56	146,616	100%
104	11.8	699,915	5.2	0.88	0.88	0.00	0.88	1.77	322.61	146,641	100%
106	10.8	701,124	5.2	0.88	0.88	0.00	0.88	1.77	322.66	146,662	100%
108	9.9	702,210	5.2	0.88	0.88	0.00	0.88	1.77	322.70	146,682	100%
110	9.0	703,184	5.2	0.88	0.88	0.00	0.88	1.77	322.74	146,699	100%
112	8.2	704,055	5.3	0.88	0.88	0.00	0.88	1.77	322.77	146,715	100%
114	7.5	704,833	5.3	0.88	0.88	0.00	0.88	1.77	322.80	146,729	100%
116	6.9	705,525	5.3	0.88	0.88	0.00	0.88	1.77	322.83	146,741	100%
118	6.3	706,138	5.3	0.88	0.88	0.00	0.88	1.77	322.86	146,752	100%
120	5.7	706,681	5.3	0.88	0.88	0.00	0.88	1.77	322.88	146,762	100%
122	5.2	707,158	5.3	0.88	0.88	0.00	0.88	1.77	322.90	146,771	100%
124	4.8	707,575	5.3	0.88	0.88	0.00	0.88	1.77	322.91	146,778	100%
126	4.4	707,938	5.3	0.88	0.88	0.00	0.88	1.77	322.93	146,785	100%
128	4.0	708,251	5.3	0.88	0.88	0.00	0.88	1.77	322.94	146,790	100%
130	3.7	708,519	5.3	0.88	0.88	0.00	0.88	1.77	322.95	146,795	100%
132	3.3	708,745	5.3	0.88	0.88	0.00	0.88	1.77	322.96	146,799	100%
134	3.0	708,934	5.3	0.88	0.88	0.00	0.88	1.77	322.97	146,802	100%
136	2.8	709,087	5.3	0.88	0.88	0.00	0.88	1.77	322.97	146,805	100%
138	2.5	709,209	5.3	0.88	0.88	0.00	0.88	1.77	322.98	146,807	100%
140	2.3	709,303	5.3	0.88	0.88	0.00	0.88	1.77	322.98	146,809	100%
142	2.1	709,369	5.3	0.88	0.88	0.00	0.88	1.77	322.98	146,810	100%
144	1.9	709,412	5.3	0.88	0.88	0.00	0.88	1.77	322.98	146,811	100%
146	1.8	709,433	5.3	0.88	0.88	0.00	0.88	1.77	322.99	146,811	100%
148	1.6	709,433	5.3	0.88	0.88	0.00	0.88	1.77	322.99	146,811	100%
150	1.5	709,415	5.3	0.88	0.88	0.00	0.88	1.77	322.98	146,811	100%
152	1.3	709,381	5.3	0.88	0.88	0.00	0.88	1.77	322.98	146,810	100%
154	1.2	709,331	5.3	0.88	0.88	0.00	0.88	1.77	322.98	146,810	100%
156	1.1	709,267	5.3	0.88	0.88	0.00	0.88	1.77	322.98	146,808	100%
158	1.0	709,190	5.3	0.88	0.88	0.00	0.88	1.77	322.98	146,807	100%
160	0.9	709,101	5.3	0.88	0.88	0.00	0.88	1.77	322.97	146,805	100%
162	0.9	709,002	5.3	0.88	0.88	0.00	0.88	1.77	322.97	146,804	100%
164	0.8	708,893	5.3	0.88	0.88	0.00	0.88	1.77	322.96	146,802	100%
166	0.7	708,775	5.3	0.88	0.88	0.00	0.88	1.77	322.96	146,800	100%
168	0.7	708,649	5.3	0.88	0.88	0.00	0.88	1.77	322.95	146,797	100%
170	0.6	708,516	5.3	0.88	0.88	0.00	0.88	1.77	322.95	146,795	100%
172	0.5	708,376	5.3	0.88	0.88	0.00	0.88	1.77	322.94	146,793	100%
174	0.5	708,229	5.3	0.88	0.88	0.00	0.88	1.77	322.94	146,790	100%
176	0.5	708,077	5.3	0.88	0.88	0.00	0.88	1.77	322.93	146,787	100%
178	0.4	707,920	5.3	0.88	0.88	0.00	0.88	1.77	322.93	146,784	100%
180	0.4	707,758	5.3	0.88	0.88	0.00	0.88	1.77	322.92	146,781	100%
182	0.3	707,591	5.3	0.88	0.88	0.00	0.88	1.77	322.91	146,778	100%
184	0.3	707,421	5.3	0.88	0.88	0.00	0.88	1.77	322.91	146,775	100%
186	0.3	707,247	5.3	0.88	0.88	0.00	0.88	1.77	322.90	146,772	100%
188	0.3	707,070	5.3	0.88	0.88	0.00	0.88	1.77	322.89	146,769	100%
190	0.2	706,890	5.3	0.88	0.88	0.00	0.88	1.77	322.89	146,766	100%
192	0.2	706,707	5.3	0.88	0.88	0.00	0.88	1.77	322.88	146,763	100%
194	0.2	706,522	5.3	0.88	0.88	0.00	0.88	1.77	322.87	146,759	100%
196	0.2	706,334	5.3	0.88	0.88	0.00	0.88	1.77	322.86	146,756	100%
198	0.2	706,144	5.3	0.88	0.88	0.00	0.88	1.77	322.86	146,753	100%
200	0.2	705,952	5.3	0.88	0.88	0.00	0.88	1.77	322.85	146,749	100%
202	0.1	705,759	5.3	0.88	0.88	0.00	0.88	1.77	322.84	146,746	100%
204	0.1	705,564	5.3	0.88	0.88	0.00	0.88	1.77	322.83	146,742	100%
206	0.1	705,367	5.3	0.88	0.88	0.00	0.88	1.77	322.83	146,739	100%

**Sediment Basin #5 Colon Mine Phase 1 Hydrograph
10-Yr Storm**

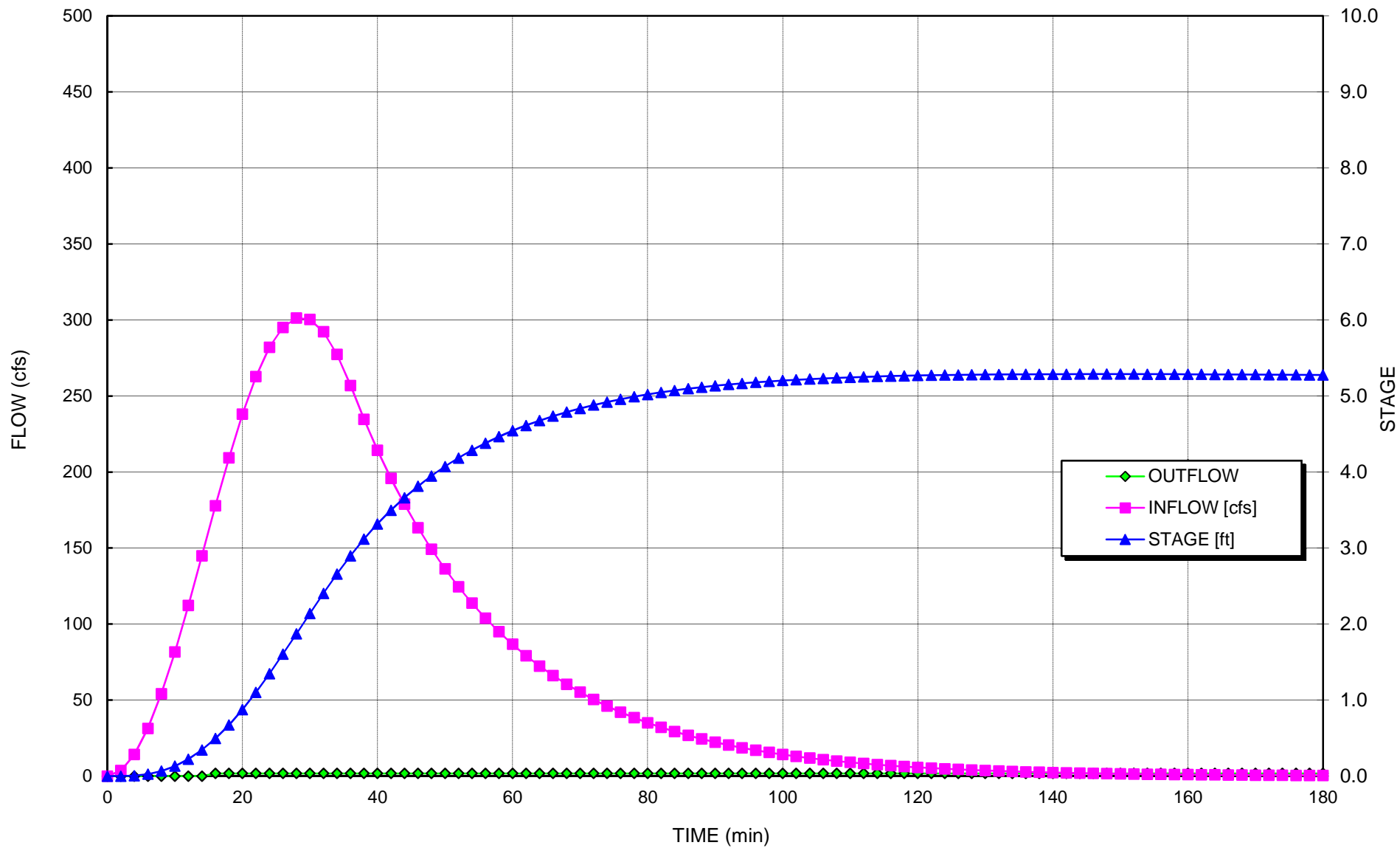

Qp = 252.52 cfs
 Tp = 28.56 minutes
 dT = Max of 2 minutes
 or 1.0% of increment to peak

Sediment Basin # 5 **Colon**
 Phase 2
10 - year Storm Event

Number of Riser/Barrel Assemblies = 2
 Diameter of Barrel = 24 (in)
 Height of Riser above barrel = 3.3 (ft)
 Height of Riser from bottom of barrel = 5.3 (ft) elevation 260.30
 Emergency Spillway = 6 (ft) elevation 261.00
 Total Height of Dam = 7 (ft) elevation 262.00
 Length of Emergency Spillway = 20 (ft)
 Diameter of Riser = 48 (in)
 Permanent Pond Stage = 0 (ft) elevation 255.0

b = 1.1
 Ks = 114,650

4.0E-03 Settling Velocity of design particle (fps)
 2 Effective number of cells (2 is construction site #)

100% Minimum Settling Efficiency	
4.5 ft Maximum Stage	259.46 msl elevation
1.8 cfs Peak outflow	
1.8 cfs Peak Riser/Barrel outflow	
0.0 cfs peak weir flow	

Notes:

1. Length of emergency spillway is the bottom width of the emergency spillway.
2. Settling efficiency neglects permanent pond volume

TIME (min)	INFLOW [cfs]	STORAGE [cu ft]	STAGE [ft]	Skimmer Flow [cfs]	RISER CAPACIT Y [cfs]	WEIR FLOW [cfs]	BARREL CAPACIT Y [cfs]	TOTAL OUTFLOW [cfs]	Bound Discharge [cfs]	Estimated Surface Area (sf)	Settling Efficiency [%]
0	0.0	0	0.0	0.00	0.00	0.00	0.00	0.00	0.00	-	N/A
2	3.0	0	0.0	0.00	0.00	0.00	0.00	0.00	0.00	-	N/A
4	12.0	365	0.0	0.00	0.00	0.00	0.00	0.00	168.15	76,434	N/A
6	26.5	1,809	0.0	0.00	0.00	0.00	0.00	0.00	193.02	87,736	N/A
8	45.8	4,991	0.1	0.00	0.00	0.00	0.00	0.00	210.67	95,759	N/A
10	69.0	10,489	0.1	0.00	0.00	0.00	0.00	0.00	224.60	102,091	N/A
12	94.9	18,769	0.2	0.00	0.00	0.00	0.00	0.00	236.15	107,343	N/A
14	122.4	30,161	0.3	0.00	0.00	0.00	0.00	0.00	246.01	111,823	N/A
16	150.0	44,847	0.4	0.00	0.00	0.00	0.00	0.00	254.57	115,713	N/A
18	176.5	62,850	0.6	0.88	0.88	0.00	0.88	1.77	262.08	119,129	100%
20	200.6	83,819	0.8	0.88	0.88	0.00	0.88	1.77	268.67	122,123	100%
22	221.1	107,677	0.9	0.88	0.88	0.00	0.88	1.77	274.54	124,789	100%
24	237.0	133,993	1.2	0.88	0.88	0.00	0.88	1.77	279.76	127,163	100%
26	247.6	162,218	1.4	0.88	0.88	0.00	0.88	1.77	284.41	129,276	100%
28	252.3	191,713	1.6	0.88	0.88	0.00	0.88	1.77	288.53	131,151	100%
30	250.9	221,774	1.8	0.88	0.88	0.00	0.88	1.77	292.18	132,808	100%
32	243.6	251,675	2.1	0.88	0.88	0.00	0.88	1.77	295.38	134,264	100%
34	230.6	280,692	2.3	0.88	0.88	0.00	0.88	1.77	298.17	135,533	100%
36	212.9	308,147	2.5	0.88	0.88	0.00	0.88	1.77	300.58	136,628	100%
38	194.3	333,478	2.7	0.88	0.88	0.00	0.88	1.77	302.64	137,562	100%
40	177.4	356,585	2.8	0.88	0.88	0.00	0.88	1.77	304.39	138,359	100%
42	162.0	377,663	3.0	0.88	0.88	0.00	0.88	1.77	305.90	139,045	100%
44	147.9	396,889	3.1	0.88	0.88	0.00	0.88	1.77	307.21	139,642	100%
46	135.0	414,423	3.2	0.88	0.88	0.00	0.88	1.77	308.36	140,163	100%
48	123.3	430,413	3.3	0.88	0.88	0.00	0.88	1.77	309.37	140,621	100%
50	112.5	444,993	3.5	0.88	0.88	0.00	0.88	1.77	310.26	141,026	100%
52	102.7	458,285	3.5	0.88	0.88	0.00	0.88	1.77	311.04	141,384	100%
54	93.8	470,403	3.6	0.88	0.88	0.00	0.88	1.77	311.75	141,702	100%
56	85.6	481,447	3.7	0.88	0.88	0.00	0.88	1.77	312.37	141,986	100%
58	78.2	491,512	3.8	0.88	0.88	0.00	0.88	1.77	312.93	142,240	100%
60	71.4	500,683	3.8	0.88	0.88	0.00	0.88	1.77	313.43	142,466	100%
62	65.2	509,037	3.9	0.88	0.88	0.00	0.88	1.77	313.87	142,670	100%
64	59.5	516,646	4.0	0.88	0.88	0.00	0.88	1.77	314.28	142,852	100%
66	54.3	523,574	4.0	0.88	0.88	0.00	0.88	1.77	314.64	143,017	100%
68	49.6	529,881	4.1	0.88	0.88	0.00	0.88	1.77	314.96	143,164	100%
70	45.3	535,621	4.1	0.88	0.88	0.00	0.88	1.77	315.25	143,297	100%
72	41.3	540,842	4.1	0.88	0.88	0.00	0.88	1.77	315.52	143,417	100%
74	37.7	545,591	4.2	0.88	0.88	0.00	0.88	1.77	315.76	143,525	100%
76	34.5	549,908	4.2	0.88	0.88	0.00	0.88	1.77	315.97	143,623	100%
78	31.5	553,831	4.2	0.88	0.88	0.00	0.88	1.77	316.16	143,711	100%
80	28.7	557,395	4.2	0.88	0.88	0.00	0.88	1.77	316.34	143,790	100%
82	26.2	560,629	4.3	0.88	0.88	0.00	0.88	1.77	316.50	143,862	100%
84	23.9	563,564	4.3	0.88	0.88	0.00	0.88	1.77	316.64	143,927	100%

86	21.9	566,225	4.3	0.88	0.88	0.00	0.88	1.77	316.77	143,985	100%
88	20.0	568,636	4.3	0.88	0.88	0.00	0.88	1.77	316.88	144,038	100%
90	18.2	570,818	4.3	0.88	0.88	0.00	0.88	1.77	316.99	144,086	100%
92	16.6	572,793	4.3	0.88	0.88	0.00	0.88	1.77	317.08	144,129	100%
94	15.2	574,577	4.4	0.88	0.88	0.00	0.88	1.77	317.17	144,167	100%
96	13.9	576,187	4.4	0.88	0.88	0.00	0.88	1.77	317.24	144,202	100%
98	12.7	577,639	4.4	0.88	0.88	0.00	0.88	1.77	317.31	144,233	100%
100	11.6	578,946	4.4	0.88	0.88	0.00	0.88	1.77	317.38	144,261	100%
102	10.6	580,121	4.4	0.88	0.88	0.00	0.88	1.77	317.43	144,287	100%
104	9.6	581,175	4.4	0.88	0.88	0.00	0.88	1.77	317.48	144,309	100%
106	8.8	582,119	4.4	0.88	0.88	0.00	0.88	1.77	317.52	144,329	100%
108	8.0	582,962	4.4	0.88	0.88	0.00	0.88	1.77	317.56	144,347	100%
110	7.3	583,714	4.4	0.88	0.88	0.00	0.88	1.77	317.60	144,363	100%
112	6.7	584,381	4.4	0.88	0.88	0.00	0.88	1.77	317.63	144,378	100%
114	6.1	584,972	4.4	0.88	0.88	0.00	0.88	1.77	317.66	144,390	100%
116	5.6	585,494	4.4	0.88	0.88	0.00	0.88	1.77	317.68	144,401	100%
118	5.1	585,951	4.4	0.88	0.88	0.00	0.88	1.77	317.70	144,411	100%
120	4.6	586,350	4.4	0.88	0.88	0.00	0.88	1.77	317.72	144,420	100%
122	4.2	586,696	4.4	0.88	0.88	0.00	0.88	1.77	317.74	144,427	100%
124	3.9	586,994	4.4	0.88	0.88	0.00	0.88	1.77	317.75	144,433	100%
126	3.5	587,247	4.4	0.88	0.88	0.00	0.88	1.77	317.76	144,439	100%
128	3.2	587,460	4.5	0.88	0.88	0.00	0.88	1.77	317.77	144,443	100%
130	2.9	587,635	4.5	0.88	0.88	0.00	0.88	1.77	317.78	144,447	100%
132	2.7	587,777	4.5	0.88	0.88	0.00	0.88	1.77	317.79	144,450	100%
134	2.5	587,888	4.5	0.88	0.88	0.00	0.88	1.77	317.79	144,452	100%
136	2.2	587,971	4.5	0.88	0.88	0.00	0.88	1.77	317.80	144,454	100%
138	2.0	588,029	4.5	0.88	0.88	0.00	0.88	1.77	317.80	144,455	100%
140	1.9	588,063	4.5	0.88	0.88	0.00	0.88	1.77	317.80	144,456	100%
142	1.7	588,075	4.5	0.88	0.88	0.00	0.88	1.77	317.80	144,456	100%
144	1.6	588,068	4.5	0.88	0.88	0.00	0.88	1.77	317.80	144,456	100%
146	1.4	588,044	4.5	0.88	0.88	0.00	0.88	1.77	317.80	144,455	100%
148	1.3	588,002	4.5	0.88	0.88	0.00	0.88	1.77	317.80	144,455	100%
150	1.2	587,946	4.5	0.88	0.88	0.00	0.88	1.77	317.80	144,453	100%
152	1.1	587,877	4.5	0.88	0.88	0.00	0.88	1.77	317.79	144,452	100%
154	1.0	587,795	4.5	0.88	0.88	0.00	0.88	1.77	317.79	144,450	100%
156	0.9	587,702	4.5	0.88	0.88	0.00	0.88	1.77	317.79	144,448	100%
158	0.8	587,598	4.5	0.88	0.88	0.00	0.88	1.77	317.78	144,446	100%
160	0.8	587,485	4.5	0.88	0.88	0.00	0.88	1.77	317.78	144,444	100%
162	0.7	587,363	4.5	0.88	0.88	0.00	0.88	1.77	317.77	144,441	100%
164	0.6	587,234	4.4	0.88	0.88	0.00	0.88	1.77	317.76	144,438	100%
166	0.6	587,097	4.4	0.88	0.88	0.00	0.88	1.77	317.76	144,435	100%
168	0.5	586,954	4.4	0.88	0.88	0.00	0.88	1.77	317.75	144,432	100%
170	0.5	586,805	4.4	0.88	0.88	0.00	0.88	1.77	317.74	144,429	100%
172	0.4	586,650	4.4	0.88	0.88	0.00	0.88	1.77	317.74	144,426	100%
174	0.4	586,491	4.4	0.88	0.88	0.00	0.88	1.77	317.73	144,422	100%
176	0.4	586,326	4.4	0.88	0.88	0.00	0.88	1.77	317.72	144,419	100%
178	0.3	586,158	4.4	0.88	0.88	0.00	0.88	1.77	317.71	144,415	100%
180	0.3	585,986	4.4	0.88	0.88	0.00	0.88	1.77	317.71	144,412	100%
182	0.3	585,810	4.4	0.88	0.88	0.00	0.88	1.77	317.70	144,408	100%
184	0.3	585,632	4.4	0.88	0.88	0.00	0.88	1.77	317.69	144,404	100%
186	0.2	585,450	4.4	0.88	0.88	0.00	0.88	1.77	317.68	144,400	100%
188	0.2	585,266	4.4	0.88	0.88	0.00	0.88	1.77	317.67	144,396	100%
190	0.2	585,079	4.4	0.88	0.88	0.00	0.88	1.77	317.66	144,392	100%
192	0.2	584,890	4.4	0.88	0.88	0.00	0.88	1.77	317.65	144,388	100%
194	0.2	584,699	4.4	0.88	0.88	0.00	0.88	1.77	317.65	144,384	100%
196	0.1	584,506	4.4	0.88	0.88	0.00	0.88	1.77	317.64	144,380	100%
198	0.1	584,312	4.4	0.88	0.88	0.00	0.88	1.77	317.63	144,376	100%
200	0.1	584,116	4.4	0.88	0.88	0.00	0.88	1.77	317.62	144,372	100%
202	0.1	583,919	4.4	0.88	0.88	0.00	0.88	1.77	317.61	144,368	100%
204	0.1	583,720	4.4	0.88	0.88	0.00	0.88	1.77	317.60	144,364	100%

Sediment Basin #5 Colon Mine Phase 2 Hydrograph 10-Yr Storm

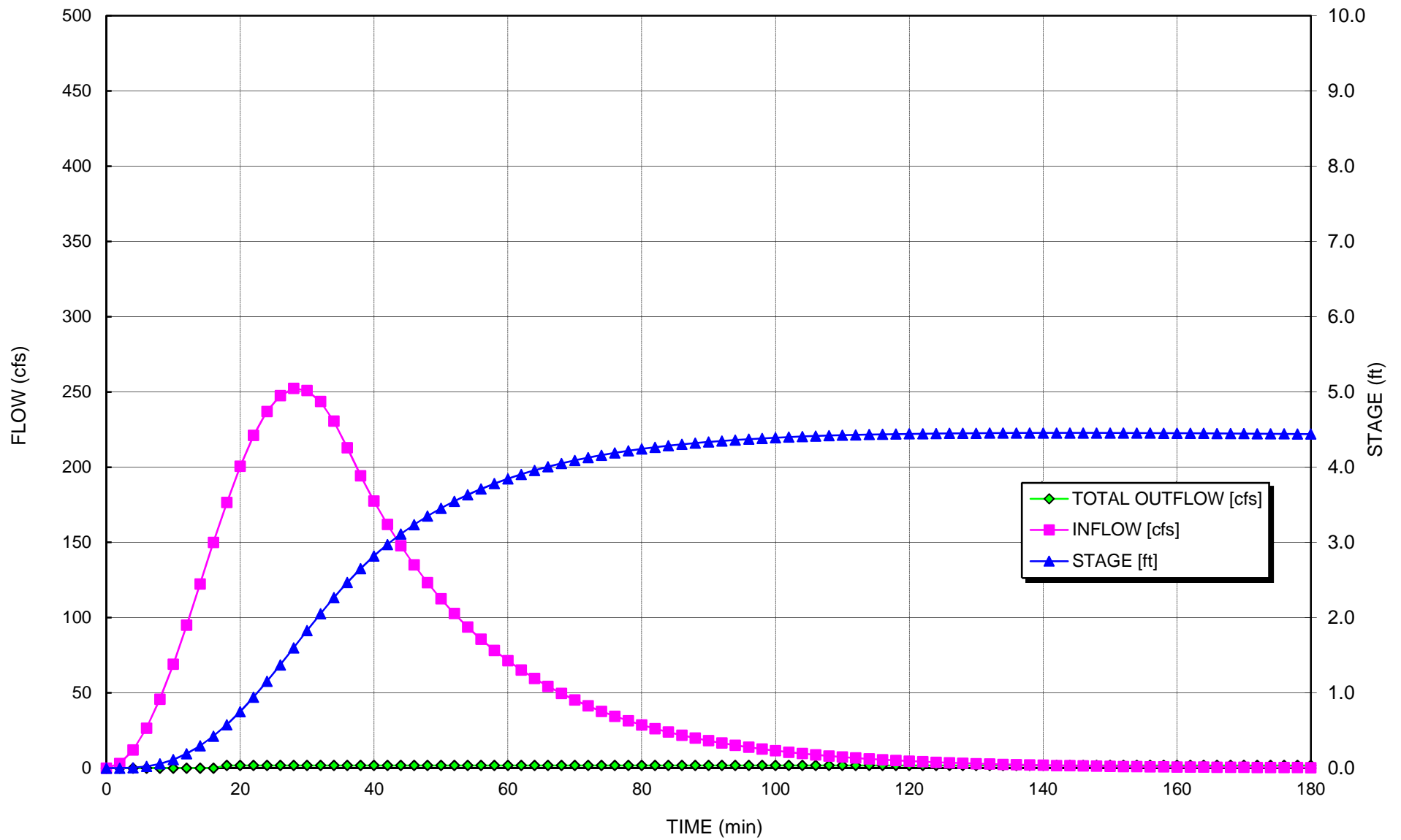

Qp = 310.28 cfs
 Tp = 28.91 minutes
 dT = Max of 2 minutes
 or 1.0% of increment to peak

Sediment Basin # 5 Colon
 Phase 2
25 - year Storm Event

Number of Riser/Barrel Assemblies = 2
 Diameter of Barrel = 24 (in)
 Height of Riser above barrel = 3.3 (ft)
 Height of Riser from bottom of barrel = 5.3 (ft) elevation 260.30
 Emergency Spillway = 6.0 (ft) elevation 261.00
 Total Height of Dam = 7.0 (ft) elevation 262.00
 Length of Emergency Spillway = 20 (ft)
 Diameter of Riser = 48 (in)
 Permanent Pond Stage = 0 (ft) elevation 255.0

b = 1.1
 Ks = 114,650

4.0E-03 Settling Velocity of design particle (fps)
 2 Effective number of cells (2 is construction site #)

100% Minimum Settling Efficiency	
5.4 ft Maximum Stage	260.4 msl elevation
5.1 cfs Peak outflow	
5.1 cfs Peak Riser/Barrel outflow	
0.0 cfs peak weir flow	

Notes:

1. Length of emergency spillway is the bottom width of the emergency spillway.
2. Settling efficiency neglects permanent pond volume

TIME (min)	INFLOW [cfs]	STORAGE [cu ft]	STAGE [ft]	Skimmer Flow [cfs]	RISER CAPACIT Y [cfs]	WEIR FLOW [cfs]	BARREL CAPACITY [cfs]	TOTAL OUTFL OW [cfs]	Bound Discharge [cfs]	Estimated Surface Area (sf)	Settling Efficiency [%]
0	0.0	0	0.0	0.00	0.00	0.00	0.00	0.00	0.00	-	N/A
2	3.6	0	0.0	0.00	0.00	0.00	0.00	0.00	0.00	-	N/A
4	14.4	438	0.0	0.00	0.00	0.00	0.00	0.00	170.80	77,638	N/A
6	31.8	2,169	0.0	0.00	0.00	0.00	0.00	0.00	196.06	89,120	N/A
8	55.0	5,987	0.1	0.00	0.00	0.00	0.00	0.00	214.00	97,273	N/A
10	82.9	12,588	0.1	0.00	0.00	0.00	0.00	0.00	228.16	103,709	N/A
12	114.2	22,538	0.2	0.00	0.00	0.00	0.00	0.00	239.91	109,049	N/A
14	147.4	36,244	0.3	0.00	0.00	0.00	0.00	0.00	249.94	113,608	N/A
16	181.0	53,937	0.5	0.88	0.88	0.00	0.88	1.77	258.65	117,569	100%
18	213.4	75,449	0.7	0.88	0.88	0.00	0.88	1.77	266.25	121,021	100%
20	243.0	100,845	0.9	0.88	0.88	0.00	0.88	1.77	272.99	124,086	100%
22	268.5	129,797	1.1	0.88	0.88	0.00	0.88	1.77	278.99	126,815	100%
24	288.7	161,808	1.4	0.88	0.88	0.00	0.88	1.77	284.35	129,248	100%
26	302.6	196,239	1.6	0.88	0.88	0.00	0.88	1.77	289.11	131,415	100%
28	309.5	232,336	1.9	0.88	0.88	0.00	0.88	1.77	293.35	133,342	100%
30	309.2	269,266	2.2	0.88	0.88	0.00	0.88	1.77	297.11	135,049	100%
32	301.6	306,158	2.5	0.88	0.88	0.00	0.88	1.77	300.41	136,552	100%
34	287.2	342,142	2.7	0.88	0.88	0.00	0.88	1.77	303.31	137,866	100%
36	266.5	376,392	3.0	0.88	0.88	0.00	0.88	1.77	305.81	139,005	100%
38	243.9	408,163	3.2	0.88	0.88	0.00	0.88	1.77	307.95	139,979	100%
40	222.9	437,221	3.4	0.88	0.88	0.00	0.88	1.77	309.79	140,812	100%
42	203.8	463,761	3.6	0.88	0.88	0.00	0.88	1.77	311.36	141,529	100%
44	186.2	488,001	3.8	0.88	0.88	0.00	0.88	1.77	312.73	142,152	100%
46	170.2	510,138	3.9	0.88	0.88	0.00	0.88	1.77	313.93	142,696	100%
48	155.6	530,353	4.1	0.88	0.88	0.00	0.88	1.77	314.99	143,175	100%
50	142.2	548,811	4.2	0.88	0.88	0.00	0.88	1.77	315.92	143,598	100%
52	130.0	565,664	4.3	0.88	0.88	0.00	0.88	1.77	316.74	143,973	100%
54	118.8	581,049	4.4	0.88	0.88	0.00	0.88	1.77	317.47	144,306	100%
56	108.6	595,093	4.5	0.88	0.88	0.00	0.88	1.77	318.13	144,604	100%
58	99.2	607,911	4.6	0.88	0.88	0.00	0.88	1.77	318.71	144,870	100%
60	90.7	619,608	4.7	0.88	0.88	0.00	0.88	1.77	319.24	145,108	100%
62	82.9	630,281	4.7	0.88	0.88	0.00	0.88	1.77	319.71	145,322	100%
64	75.8	640,019	4.8	0.88	0.88	0.00	0.88	1.77	320.13	145,514	100%
66	69.3	648,900	4.9	0.88	0.88	0.00	0.88	1.77	320.51	145,687	100%
68	63.3	656,999	4.9	0.88	0.88	0.00	0.88	1.77	320.85	145,843	100%
70	57.9	664,384	5.0	0.88	0.88	0.00	0.88	1.77	321.16	145,983	100%
72	52.9	671,115	5.0	0.88	0.88	0.00	0.88	1.77	321.44	146,110	100%
74	48.3	677,250	5.1	0.88	0.88	0.00	0.88	1.77	321.69	146,225	100%
76	44.2	682,838	5.1	0.88	0.88	0.00	0.88	1.77	321.92	146,329	100%
78	40.4	687,928	5.1	0.88	0.88	0.00	0.88	1.77	322.13	146,422	100%
80	36.9	692,562	5.2	0.88	0.88	0.00	0.88	1.77	322.32	146,507	100%
82	33.7	696,779	5.2	0.88	0.88	0.00	0.88	1.77	322.48	146,584	100%
84	30.8	700,615	5.2	0.88	0.88	0.00	0.88	1.77	322.64	146,653	100%

86	28.2	704,103	5.3	0.88	0.88	0.00	0.88	1.77	322.78	146,716	100%
88	25.8	707,273	5.3	0.88	0.88	0.00	0.88	1.77	322.90	146,773	100%
90	23.5	710,152	5.3	0.88	0.88	0.00	0.88	1.77	323.01	146,824	100%
92	21.5	712,765	5.3	0.88	0.93	0.00	31.36	1.86	323.12	146,871	100%
94	19.7	715,124	5.3	0.88	1.07	0.00	31.42	2.13	323.21	146,913	100%
96	18.0	717,228	5.3	0.88	1.23	0.00	31.47	2.46	323.29	146,950	100%
98	16.4	719,090	5.4	0.88	1.40	0.00	31.51	2.80	323.36	146,983	100%
100	15.0	720,725	5.4	0.88	1.57	0.00	31.55	3.14	323.43	147,011	100%
102	13.7	722,150	5.4	0.88	1.73	0.00	31.59	3.46	323.48	147,036	100%
104	12.5	723,382	5.4	0.88	1.88	0.00	31.62	3.75	323.53	147,058	100%
106	11.5	724,437	5.4	0.88	2.01	0.00	31.64	4.02	323.57	147,077	100%
108	10.5	725,332	5.4	0.88	2.12	0.00	31.67	4.25	323.60	147,092	100%
110	9.6	726,080	5.4	0.88	2.22	0.00	31.68	4.44	323.63	147,105	100%
112	8.8	726,696	5.4	0.88	2.31	0.00	31.70	4.61	323.66	147,116	100%
114	8.0	727,193	5.4	0.88	2.38	0.00	31.71	4.75	323.67	147,125	100%
116	7.3	727,583	5.4	0.88	2.43	0.00	31.72	4.86	323.69	147,131	100%
118	6.7	727,878	5.4	0.88	2.47	0.00	31.73	4.94	323.70	147,137	100%
120	6.1	728,087	5.4	0.88	2.50	0.00	31.73	5.00	323.71	147,140	100%
122	5.6	728,220	5.4	0.88	2.52	0.00	31.74	5.04	323.71	147,143	100%
124	5.1	728,285	5.4	0.88	2.53	0.00	31.74	5.06	323.72	147,144	100%
126	4.7	728,290	5.4	0.88	2.53	0.00	31.74	5.06	323.72	147,144	100%
128	4.3	728,243	5.4	0.88	2.52	0.00	31.74	5.05	323.71	147,143	100%
130	3.9	728,148	5.4	0.88	2.51	0.00	31.74	5.02	323.71	147,141	100%
132	3.6	728,014	5.4	0.88	2.49	0.00	31.73	4.98	323.71	147,139	100%
134	3.3	727,843	5.4	0.88	2.47	0.00	31.73	4.93	323.70	147,136	100%
136	3.0	727,642	5.4	0.88	2.44	0.00	31.72	4.88	323.69	147,132	100%
138	2.7	727,414	5.4	0.88	2.41	0.00	31.72	4.81	323.68	147,129	100%
140	2.5	727,163	5.4	0.88	2.37	0.00	31.71	4.74	323.67	147,124	100%
142	2.3	726,892	5.4	0.88	2.33	0.00	31.70	4.67	323.66	147,119	100%
144	2.1	726,605	5.4	0.88	2.29	0.00	31.70	4.59	323.65	147,114	100%
146	1.9	726,304	5.4	0.88	2.25	0.00	31.69	4.51	323.64	147,109	100%
148	1.7	725,991	5.4	0.88	2.21	0.00	31.68	4.42	323.63	147,104	100%
150	1.6	725,668	5.4	0.88	2.17	0.00	31.67	4.33	323.62	147,098	100%
152	1.4	725,339	5.4	0.88	2.12	0.00	31.67	4.25	323.60	147,092	100%
154	1.3	725,003	5.4	0.88	2.08	0.00	31.66	4.16	323.59	147,086	100%
156	1.2	724,662	5.4	0.88	2.04	0.00	31.65	4.07	323.58	147,080	100%
158	1.1	724,319	5.4	0.88	1.99	0.00	31.64	3.99	323.56	147,074	100%
160	1.0	723,974	5.4	0.88	1.95	0.00	31.63	3.90	323.55	147,068	100%
162	0.9	723,627	5.4	0.88	1.91	0.00	31.62	3.81	323.54	147,062	100%
164	0.8	723,281	5.4	0.88	1.86	0.00	31.62	3.73	323.52	147,056	100%
166	0.8	722,935	5.4	0.88	1.82	0.00	31.61	3.64	323.51	147,050	100%
168	0.7	722,590	5.4	0.88	1.78	0.00	31.60	3.56	323.50	147,044	100%
170	0.6	722,247	5.4	0.88	1.74	0.00	31.59	3.48	323.48	147,038	100%
172	0.6	721,907	5.4	0.88	1.70	0.00	31.58	3.40	323.47	147,032	100%
174	0.5	721,569	5.4	0.88	1.66	0.00	31.57	3.33	323.46	147,026	100%
176	0.5	721,235	5.4	0.88	1.63	0.00	31.57	3.25	323.44	147,020	100%
178	0.5	720,904	5.4	0.88	1.59	0.00	31.56	3.18	323.43	147,015	100%
180	0.4	720,576	5.4	0.88	1.55	0.00	31.55	3.11	323.42	147,009	100%
182	0.4	720,253	5.4	0.88	1.52	0.00	31.54	3.04	323.41	147,003	100%
184	0.3	719,933	5.4	0.88	1.49	0.00	31.53	2.97	323.39	146,997	100%
186	0.3	719,617	5.4	0.88	1.45	0.00	31.53	2.91	323.38	146,992	100%
188	0.3	719,306	5.4	0.88	1.42	0.00	31.52	2.85	323.37	146,986	100%
190	0.3	718,999	5.4	0.88	1.39	0.00	31.51	2.79	323.36	146,981	100%
192	0.2	718,696	5.4	0.88	1.36	0.00	31.50	2.73	323.35	146,976	100%
194	0.2	718,398	5.3	0.88	1.34	0.00	31.50	2.67	323.33	146,970	100%
196	0.2	718,103	5.3	0.88	1.31	0.00	31.49	2.62	323.32	146,965	100%
198	0.2	717,814	5.3	0.88	1.28	0.00	31.48	2.56	323.31	146,960	100%
200	0.2	717,528	5.3	0.88	1.26	0.00	31.47	2.51	323.30	146,955	100%
202	0.2	717,247	5.3	0.88	1.23	0.00	31.47	2.46	323.29	146,950	100%
204	0.1	716,969	5.3	0.88	1.21	0.00	31.46	2.42	323.28	146,945	100%
206	0.1	716,696	5.3	0.88	1.19	0.00	31.45	2.37	323.27	146,940	100%

Sediment Basin #5 Colon Mine Phase 2 Hydrograph 25-Yr Storm

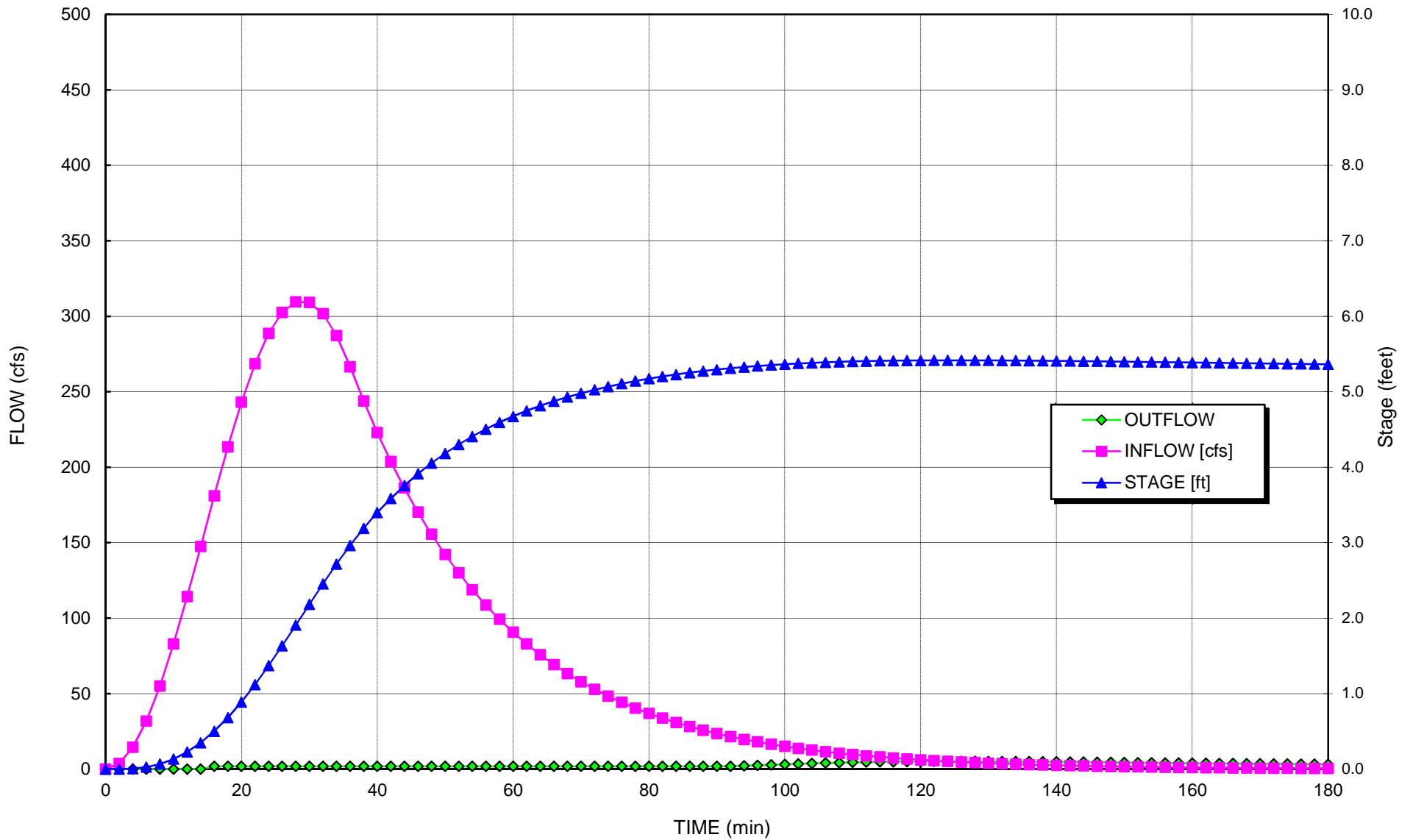

Qp = 402.1 cfs
 Tp = 29.4 minutes
 dT = Max of 2 minutes
 or 1.0% of increment to peak

Sediment Basin # 5 **Colon**
 Phase 2
100 - year Storm Event

b = 1.1
 Ks = 114,650

Number of Riser/Barrel Assemblies = 2
 Diameter of Barrel = 24 (in)
 Height of Riser above barrel = 3.3 (ft)
 Height of Riser from bottom of barrel = 5.3 (ft) elevation 260.30
 Emergency Spillway = 6.0 (ft) elevation 261.00
 Total Height of Dam = 7.0 (ft) elevation 262.00
 Length of Emergency Spillway = 20 (ft)
 Diameter of Riser = 48 (in)
 Permanent Pond Stage = 0 (ft) elevation 255.0

4.0E-03 Settling Velocity of design particle (fps)
 2 Effective number of cells (2 is construction site #)

97% Minimum Settling Efficiency	
6.1 ft Maximum Stage	261.1 msl elevation
67.5 cfs Peak outflow	
64.7 cfs Peak Riser/Barrel outflow	
2.9 cfs peak weir flow	

Notes:

1. Length of emergency spillway is the bottom width of the emergency spillway.
2. Settling efficiency neglects permanent pond volume

TIME (min)	INFLOW [cfs]	STORAGE [cu ft]	STAGE [ft]	Skimmer Flow [cfs]	RISER CAPACIT Y [cfs]	WEIR FLOW [cfs]	BARREL CAPACITY [cfs]	TOTAL OUTFLOW [cfs]	Bound Discharge [cfs]	Estimated Surface Area (sf)	Settling Efficiency [%]
0	0.0	0	0.0	0.00	0.00	0.00	0.00	0.00	0.00	-	N/A
2	4.6	0	0.0	0.00	0.00	0.00	0.00	0.00	0.00	-	N/A
4	18.1	549	0.0	0.00	0.00	0.00	0.00	0.00	174.16	79,166	N/A
6	39.9	2,719	0.0	0.00	0.00	0.00	0.00	0.00	199.93	90,876	N/A
8	69.1	7,511	0.1	0.00	0.00	0.00	0.00	0.00	218.23	99,193	N/A
10	104.3	15,802	0.2	0.00	0.00	0.00	0.00	0.00	232.68	105,762	N/A
12	143.8	28,315	0.3	0.00	0.00	0.00	0.00	0.00	244.67	111,216	N/A
14	186.0	45,576	0.4	0.00	0.00	0.00	0.00	0.00	254.92	115,874	N/A
16	228.9	67,900	0.6	0.88	0.88	0.00	0.88	1.77	263.84	119,926	100%
18	270.5	95,154	0.8	0.88	0.88	0.00	0.88	1.77	271.62	123,466	100%
20	308.9	127,401	1.1	0.88	0.88	0.00	0.88	1.77	278.55	126,611	100%
22	342.4	164,259	1.4	0.88	0.88	0.00	0.88	1.77	284.71	129,415	100%
24	369.5	205,141	1.7	0.88	0.88	0.00	0.88	1.77	290.22	131,919	100%
26	389.0	249,274	2.0	0.88	0.88	0.00	0.88	1.77	295.14	134,154	100%
28	399.8	295,737	2.4	0.88	0.88	0.00	0.88	1.77	299.52	136,145	100%
30	401.7	343,506	2.7	0.88	0.88	0.00	0.88	1.77	303.41	137,914	100%
32	394.4	391,494	3.1	0.88	0.88	0.00	0.88	1.77	306.85	139,477	100%
34	378.3	438,606	3.4	0.88	0.88	0.00	0.88	1.77	309.87	140,850	100%
36	354.1	483,786	3.7	0.88	0.88	0.00	0.88	1.77	312.50	142,045	100%
38	325.1	526,066	4.0	0.88	0.88	0.00	0.88	1.77	314.77	143,075	100%
40	297.6	564,868	4.3	0.88	0.88	0.00	0.88	1.77	316.70	143,956	100%
42	272.4	600,369	4.5	0.88	0.88	0.00	0.88	1.77	318.37	144,714	100%
44	249.4	632,846	4.8	0.88	0.88	0.00	0.88	1.77	319.82	145,373	100%
46	228.2	662,557	5.0	0.88	0.88	0.00	0.88	1.77	321.09	145,949	100%
48	208.9	689,735	5.2	0.88	0.88	0.00	0.88	1.77	322.20	146,455	100%
50	191.2	714,594	5.3	0.88	1.03	0.00	31.40	2.06	323.19	146,903	100%
52	175.1	737,297	5.5	0.88	3.99	0.00	31.96	7.97	324.06	147,300	100%
54	160.2	757,347	5.6	0.88	8.16	0.00	32.44	16.33	324.81	147,641	100%
56	146.7	774,616	5.7	0.88	12.59	0.00	32.85	25.19	325.44	147,928	99%
58	134.3	789,195	5.8	0.88	16.83	0.00	33.19	33.67	325.97	148,166	99%
60	122.9	801,267	5.9	0.88	20.66	0.00	33.47	41.31	326.39	148,360	99%
62	112.5	811,057	6.0	0.88	23.95	0.00	33.69	47.89	326.73	148,515	98%
64	103.0	818,810	6.0	0.88	26.67	0.29	33.87	53.62	327.00	148,637	98%
66	94.3	824,732	6.1	0.88	28.81	1.07	34.00	58.69	327.21	148,730	97%
68	86.3	829,001	6.1	0.88	30.39	1.81	34.10	62.59	327.35	148,796	97%
70	79.0	831,844	6.1	0.88	31.46	2.37	34.16	65.28	327.45	148,840	97%
72	72.3	833,487	6.1	0.88	32.08	2.72	34.20	66.88	327.50	148,865	97%
74	66.2	834,137	6.1	0.88	32.33	2.86	34.21	67.51	327.53	148,875	97%
76	60.6	833,976	6.1	0.88	32.26	2.83	34.21	67.35	327.52	148,873	97%
78	55.4	833,163	6.1	0.88	31.96	2.65	34.19	66.56	327.49	148,860	97%
80	50.8	831,829	6.1	0.88	31.45	2.37	34.16	65.27	327.45	148,840	97%
82	46.5	830,087	6.1	0.88	30.79	2.02	34.12	63.61	327.39	148,813	97%
84	42.5	828,029	6.1	0.88	30.03	1.63	34.07	61.69	327.32	148,781	97%

86	38.9	825,729	6.1	0.88	29.18	1.23	34.02	59.58	327.24	148,745	97%
88	35.6	823,250	6.1	0.88	28.27	0.85	33.97	57.38	327.15	148,707	97%
90	32.6	820,640	6.0	0.88	27.32	0.49	33.91	55.14	327.07	148,666	98%
92	29.9	817,938	6.0	0.88	26.36	0.20	33.85	52.91	326.97	148,624	98%
94	27.3	815,170	6.0	0.88	25.38	0.02	33.78	50.77	326.88	148,580	98%
96	25.0	812,357	6.0	0.88	24.40	0.00	33.72	48.79	326.78	148,536	98%
98	22.9	809,504	6.0	0.88	23.41	0.00	33.66	46.83	326.68	148,491	98%
100	21.0	806,633	5.9	0.88	22.44	0.00	33.59	44.88	326.58	148,445	98%
102	19.2	803,763	5.9	0.88	21.48	0.00	33.52	42.96	326.48	148,400	98%
104	17.6	800,910	5.9	0.88	20.54	0.00	33.46	41.08	326.38	148,354	99%
106	16.1	798,088	5.9	0.88	19.62	0.00	33.39	39.25	326.28	148,309	99%
108	14.7	795,307	5.9	0.88	18.74	0.00	33.33	37.47	326.18	148,265	99%
110	13.5	792,576	5.9	0.88	17.88	0.00	33.27	35.76	326.09	148,221	99%
112	12.3	789,902	5.8	0.88	17.05	0.00	33.20	34.10	325.99	148,177	99%
114	11.3	787,289	5.8	0.88	16.26	0.00	33.14	32.51	325.90	148,135	99%
116	10.3	784,742	5.8	0.88	15.49	0.00	33.08	30.99	325.81	148,094	99%
118	9.5	782,263	5.8	0.88	14.76	0.00	33.03	29.53	325.72	148,053	99%
120	8.7	779,855	5.8	0.88	14.07	0.00	32.97	28.14	325.63	148,014	99%
122	7.9	777,517	5.8	0.88	13.40	0.00	32.92	26.81	325.55	147,976	99%
124	7.3	775,251	5.7	0.88	12.77	0.00	32.86	25.54	325.46	147,939	99%
126	6.6	773,057	5.7	0.88	12.17	0.00	32.81	24.33	325.39	147,902	99%
128	6.1	770,933	5.7	0.88	11.59	0.00	32.76	23.18	325.31	147,867	99%
130	5.6	768,880	5.7	0.88	11.05	0.00	32.71	22.09	325.23	147,833	100%
132	5.1	766,897	5.7	0.88	10.53	0.00	32.67	21.06	325.16	147,800	100%
134	4.7	764,981	5.7	0.88	10.04	0.00	32.62	20.07	325.09	147,769	100%
136	4.3	763,131	5.7	0.88	9.57	0.00	32.58	19.14	325.02	147,738	100%
138	3.9	761,346	5.6	0.88	9.13	0.00	32.53	18.26	324.96	147,708	100%
140	3.6	759,624	5.6	0.88	8.71	0.00	32.49	17.42	324.89	147,679	100%
142	3.3	757,962	5.6	0.88	8.31	0.00	32.45	16.62	324.83	147,651	100%
144	3.0	756,360	5.6	0.88	7.93	0.00	32.42	15.87	324.77	147,624	100%
146	2.7	754,816	5.6	0.88	7.58	0.00	32.38	15.15	324.72	147,598	100%
148	2.5	753,327	5.6	0.88	7.24	0.00	32.34	14.47	324.66	147,573	100%
150	2.3	751,891	5.6	0.88	6.92	0.00	32.31	13.83	324.61	147,549	100%
152	2.1	750,507	5.6	0.88	6.61	0.00	32.28	13.22	324.56	147,525	100%
154	1.9	749,172	5.6	0.88	6.32	0.00	32.24	12.65	324.51	147,503	100%
156	1.8	747,885	5.5	0.88	6.05	0.00	32.21	12.10	324.46	147,481	100%
158	1.6	746,645	5.5	0.88	5.79	0.00	32.18	11.58	324.41	147,460	100%
160	1.5	745,449	5.5	0.88	5.55	0.00	32.15	11.09	324.37	147,439	100%
162	1.4	744,295	5.5	0.88	5.31	0.00	32.13	10.62	324.32	147,420	100%
164	1.2	743,182	5.5	0.88	5.09	0.00	32.10	10.18	324.28	147,401	100%
166	1.1	742,109	5.5	0.88	4.88	0.00	32.07	9.76	324.24	147,382	100%
168	1.0	741,073	5.5	0.88	4.68	0.00	32.05	9.37	324.20	147,365	100%
170	0.9	740,073	5.5	0.88	4.49	0.00	32.03	8.99	324.16	147,347	100%
172	0.9	739,108	5.5	0.88	4.32	0.00	32.00	8.63	324.13	147,331	100%
174	0.8	738,177	5.5	0.88	4.15	0.00	31.98	8.29	324.09	147,315	100%
176	0.7	737,277	5.5	0.88	3.98	0.00	31.96	7.97	324.06	147,299	100%
178	0.7	736,409	5.5	0.88	3.83	0.00	31.94	7.66	324.03	147,284	100%
180	0.6	735,569	5.5	0.88	3.69	0.00	31.92	7.37	323.99	147,270	100%
182	0.6	734,758	5.5	0.88	3.55	0.00	31.90	7.09	323.96	147,256	100%
184	0.5	733,974	5.5	0.88	3.42	0.00	31.88	6.83	323.93	147,242	100%
186	0.5	733,215	5.4	0.88	3.29	0.00	31.86	6.58	323.90	147,229	100%
188	0.4	732,482	5.4	0.88	3.17	0.00	31.84	6.34	323.88	147,217	100%
190	0.4	731,772	5.4	0.88	3.06	0.00	31.82	6.12	323.85	147,204	100%
192	0.4	731,085	5.4	0.88	2.95	0.00	31.81	5.90	323.82	147,192	100%
194	0.3	730,420	5.4	0.88	2.85	0.00	31.79	5.69	323.80	147,181	100%
196	0.3	729,776	5.4	0.88	2.75	0.00	31.78	5.50	323.77	147,170	100%
198	0.3	729,152	5.4	0.88	2.66	0.00	31.76	5.31	323.75	147,159	100%
200	0.3	728,548	5.4	0.88	2.57	0.00	31.75	5.14	323.73	147,148	100%
202	0.2	727,962	5.4	0.88	2.48	0.00	31.73	4.97	323.70	147,138	100%
204	0.2	727,393	5.4	0.88	2.40	0.00	31.72	4.81	323.68	147,128	100%

**Sediment Basin #5 Colon Mine Phase 2 Hydrograph
100-Yr Storm**

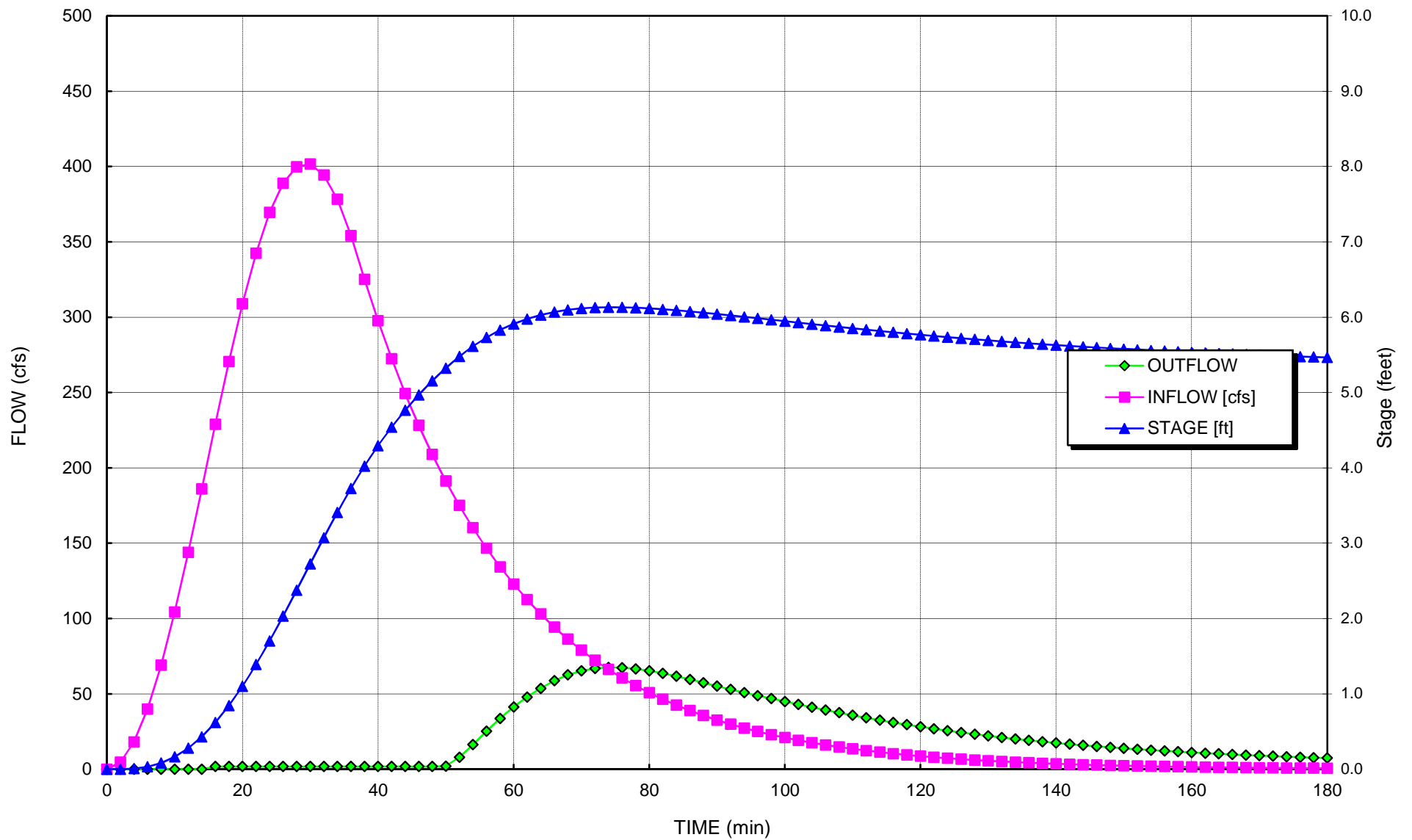

Project: Charah Colon Mine	Computed: PAW	Date: 3/4/15
Subject: Permit Application	Checked: MDP	Date: 3/6/15
Task: Sediment Basin #6	Sheet: 1	Of: 4

Objective Design the temporary sediment basin to contain the 25-year storm.

References

1. NC Erosion and Sediment Control Planning and Design Manual.
2. "Elements of Urban Stormwater Design" by H. Rooney Malcom, P.E.
3. NOAA Atlas 14, Volume 2, Version 3
4. VA Erosion and Sediment Control Handbook

Given

Phase	1	1		
Storm Event (yrs) =	10	25		
Total Drainage Area A (ac) =	15.3	15.3		
Disturbed Area (ac) =	15.3	15.3		
Curve Number CN =	89	89	Hydrographs	
Rainfall Depth P (in) =	5.28	6.28	(24-hr rainfall)	Ref 3
Peak Flow Q _p (cfs) =	93.60	114.53	Hydrographs	

Design Criteria

Required sediment storage	1,800	cf / acre of drainage
Required sediment storage	27,540	cf
Required Surface Area	435	sf/cfs of the 10-yr storm peak flow (based on the largest Phase in cfs)
Required Surface Area (SF)	49,821	of the 10-yr storm peak flow (based on the largest Phase)

Determine Shape of Basin:

Measure the area of the Basin using AutoCADD.

Calculate Volume of the Basin using Truncated Pyramid Method.

Shape factor used in hydrographs basin depth may be greater than indicated below

Elevation (ft)	Depth (ft)	Area (sf)	Volume (cf)	Cumulative Vol (cf)	Cumulative Vol (cy)
249	0	30,723	-	-	-
250	1	34,084	32,389	32,389	1,200
251	2	37,519	35,788	68,177	2,525
252	3	41,027	39,260	107,437	3,979
253	4	44,808	42,904	150,340	5,568
254	5	48,997	46,887	197,227	7,305
255	6	52,981	50,976	248,203	9,193

Design Sediment Depth (ft) = 3
 Sediment Storage (cf) = 107,437 *Required Sediment Storage Achieved*

Design Surface Area Depth (ft) = 3
 Surface Area (sf) = 41,027 *Increase Surface Area*

Project: Charah Colon Mine	Computed: PAW	Date: 3/4/15
Subject: Permit Application	Checked: MDP	Date: 3/6/15
Task: Sediment Basin #6	Sheet: 2	Of: 4

Select Skimmer

A. R. Jarrett Method

$$D = [Q / (2,310 * (H^{0.5}))]^{0.5}$$

D = Diameter of Orifice (inches)
 Q = Dewater Rate (cf/day)
 H = Head on orifice, varies based on skimmer size (ft)

Skimmer Sizes (Inches)	Head (ft)
1.5	0.125
2	0.167
2.5	0.167
3	0.250
4	0.333
5	0.333
6	0.417
8	0.500

Volume to Dewater (cf) =	107,437		
Number of Skimmers	1		
Days to Drain =	5	<i>assumed</i>	
Q each (cf/day) =	21,487		0.25 cfs
Selected Skimmer Size (inches) =	5		
Head on Skimmer (feet) =	0.333		
Diameter of Orifice (inches) =	4.0		

Route the flow through the Basin

Riser is not perforated, but skimmer is attached.

$$S = (1000/CN) - 10$$

$$\text{Runoff Depth } Q^* \text{ (inches)} = (P-0.2S)^2 / (P+0.8S)$$

$$T_p \text{ (min)} = 60.5(Q^*)A/Q_p / 1.39$$

Ref 2, III-4

Phase	1	1
Storm Event (yrs) =	10	25
S =	1.24	1.24
Runoff Depth Q* (inches) =	4.04	5.01
Time to Peak T _p (min) =	28.75	29.11

Determine Pond Storage Elevation (Z_{water}):

Pick one point near max expected water surface and the other at the mid depth.

$$Z_1 \text{ (ft)} = 3 \quad S_1 \text{ (cf)} = 107,437$$

$$Z_2 \text{ (ft)} = 5 \quad S_2 \text{ (cf)} = 197,227$$

$$b = \ln(S_2/S_1) / \ln(Z_2/Z_1) = 1.2$$

$$K_S = S_2 / Z_2^b = 29,092$$

Ref 2, III-8

Project: Charah Colon Mine	Computed: PAW	Date: 3/4/15
Subject: Permit Application	Checked: MDP	Date: 3/6/15
Task: Sediment Basin #6	Sheet: 3	Of: 4

Determine Settling Velocity

Conversion Factor =	3.281 ft/sec per m/sec	
Gravitational Acceleration, g (m/s^2) =	9.81	
Specific Gravity of soil (s_s) =	2.6	
Kinematic Viscosity of water (ν) =	1.14E-06 $m^2 / sec @ 20^\circ C$	Ref2, IV-11
Diameter of the Design Particle d_{15} =	40.00E-06 m	
Design Particle Settling Velocity =	$(g / 18) * [(s_s - 1) / \nu] d^2 =$	4.02E-03 ft/sec

Route the Storm through the Basin using the Hydrograph Model

Set Height of Emergency Spillway at (ft) = 6.10	<i>See Hydrograph</i>
Set Top of Dam at (ft) = 7.00	

Anti-Seep Collar:

Anti-Seep Collar Size = 2 * Barrel Dia
Anti-Seep Collar Size (ft) = 2
Use Anti-Seep Collar Size (ft) = 2 x 2

Minimum Concrete Base for Riser:

Diameter of Riser (in) = 18	From Hydrograph
Avg Density of Concrete (lbs/cf) = 87.6	
Density of Water (lbs/cf) = 62.4	
Riser Displacement (cf) = 8.84	$Pi * (D_R/24)^2 * Total Ht of Riser$
Convert cf to cy = 27^{-1}	
Min Concrete Needed (cy) = 0.23	
Width & Length (ft) = 2.5	
Thickness (ft) = 1.0	

Anti-Vortex Device:

Diameter of Riser (in) = 18	From Hydrograph	
Cylinder Diameter (in) = 27		Ref4, III-104, Table 3.14-D
Cylinder Thickness (gage) = 16		
Cylinder Height (in) = 8		

Project: Charah Colon Mine	Computed: PAW	Date: 3/4/15
Subject: Permit Application	Checked: MDP	Date: 3/6/15
Task: Sediment Basin #6	Sheet: 4	Of: 4

Determine Tailwater conditions to size outlet apron

Use Normal Depth Procedure (Manning's Eqn.)

Ref 2, II-7

$$A \cdot R^{2/3} = Q \cdot n / 1.49 s^{0.5}$$

$$Z_{req} = Q \cdot n / 1.49 s^{0.5}$$

$$\text{Area (A)} = bd + z(d^2)$$

$$R = \text{Area} / (b + 2d((z^2 + 1)^{0.5}))$$

$$Z_{av} = A \cdot R^{2/3}$$

- n = 0.069 6-inch diameter Rip Rap, Lined Channel
- V_p (ft/sec) = 9 Permissible Velocity for lining
- Side Slope (z) = 5 enter X for X:1
- s (ft/ft) = 0.02 Outlet Slope (estimated)
- Bottom Width (ft) = 3 3 * Barrel Diameter
- Q_B (cfs) = 3.6 Peak Flow out of the barrel 10-yr Hydrograph

Q (cfs)	Z _{req}	Flow Depth d (ft)	A (sf)	R (ft)	Z _{av}	V (ft/sec)
3.6	1.18	0.47	2.5	0.32	1.18	1.4

Flow Depth = Tailwater, d (ft) = 0.47 0.5* Barrel Diameter (ft) = 0.50

Ref 1, 8.06.3

Minimum Tailwater Conditions: d < 0.5 * Diameter of Outlet Pipe

Maximum Tailwater Conditions: d > 0.5 * Diameter of Outlet Pipe

Since the Tailwater is less than half of the diameter of the outlet, use Minimum Tailwater conditions.

Barrel Diameter (ft)	Entrance (ft)	Length (ft)	Outlet Width (ft)	Median Rip Rap Size d ₅₀	Selected Rip Rap Size (in)
1	3	8	9	0.3	Class A

Conclusion

The temporary basin can contain the 25-yr storm.

HDR Computation

Project:	Charah Colon Mine	Computed:	PAW	Date:	3/4/15
Subject:	Permit Application	Checked:	MDP	Date:	3/6/15
Task:	Riser Pipe Perforations/Skimmer Flow	Sheet:	1	Of:	2

Diameter of Riser (in) = 18
 Circumference of Riser (in) = 56.5
 Height of Riser from bottom of barrel (in) = 60 From Hydrograph
 Vertical spacing between holes (in) = 0 center to center
 Water Stage increment (ft) 0.05

Orifice Equation

$$Q = C_d * A * (2 * g * h)^{0.5}$$

Q = cfs, discharge Ref 1, p III-11
 C_d = 0.6 coefficient of discharge
 A = sf, cross sectional area
 g = 32.2 ft/sec², gravity
 h = ft, driving head measured from the center of the pipe

Row	Perforations					Skimmer	# of skimmers
	1	2	3	4	5	1	
Holes per row	0	0	0	0	0		
Hole Diameter (in)	0.75	0.75	0.75	0.75	0.75		
Spacing edge to edge (in)							
Inlet Area (sf)	0.000	0.000	0.000	0.000	0.000		
Hole Stage (in)	0.50	0.50	0.50	0.50	0.50		
Hole Stage (ft)	0.04	0.04	0.04	0.04	0.04		

Water Stage (ft)	Flow (cfs)	Flow (cfs)	Flow (cfs)	Flow (cfs)	Flow (cfs)	Flow (cfs)	Total Flow (cfs)
0.00	0.00	0.00	0.00			0.00	0.00
0.04	0.00	0.00	0.00			0.00	0.00
0.09	0.00	0.00	0.00			0.00	0.00
0.14	0.00	0.00	0.00			0.00	0.00
0.19	0.00	0.00	0.00			0.00	0.00
0.24	0.00	0.00	0.00			0.00	0.00
0.29	0.00	0.00	0.00			0.00	0.00
0.34	0.00	0.00	0.00			0.25	0.25
0.39	0.00	0.00	0.00			0.25	0.25
0.44	0.00	0.00	0.00			0.25	0.25
0.49	0.00	0.00	0.00			0.25	0.25
0.54	0.00	0.00	0.00			0.25	0.25
0.59	0.00	0.00	0.00			0.25	0.25
0.64	0.00	0.00	0.00			0.25	0.25
0.69	0.00	0.00	0.00			0.25	0.25
0.74	0.00	0.00	0.00			0.25	0.25
0.79	0.00	0.00	0.00			0.25	0.25
0.84	0.00	0.00	0.00			0.25	0.25
0.89	0.00	0.00	0.00			0.25	0.25
0.94	0.00	0.00	0.00			0.25	0.25
0.99	0.00	0.00	0.00			0.25	0.25
1.04	0.00	0.00	0.00			0.25	0.25
1.09	0.00	0.00	0.00			0.25	0.25
1.14	0.00	0.00	0.00			0.25	0.25
1.19	0.00	0.00	0.00			0.25	0.25
1.24	0.00	0.00	0.00			0.25	0.25
1.29	0.00	0.00	0.00			0.25	0.25
1.34	0.00	0.00	0.00			0.25	0.25
1.39	0.00	0.00	0.00			0.25	0.25
1.44	0.00	0.00	0.00			0.25	0.25
1.49	0.00	0.00	0.00			0.25	0.25
1.54	0.00	0.00	0.00			0.25	0.25
1.59	0.00	0.00	0.00			0.25	0.25

HDR Computation

Project:	Charah Colon Mine	Computed:	PAW	Date:	3/4/15
Subject:	Permit Application	Checked:	MDP	Date:	3/6/15
Task:	Riser Pipe Perforations/Skimmer Flow	Sheet:	2	Of:	2

1.64	0.00	0.00	0.00	0.25	0.25
1.69	0.00	0.00	0.00	0.25	0.25
1.74	0.00	0.00	0.00	0.25	0.25
1.79	0.00	0.00	0.00	0.25	0.25
1.84	0.00	0.00	0.00	0.25	0.25
1.89	0.00	0.00	0.00	0.25	0.25
1.94	0.00	0.00	0.00	0.25	0.25
1.99	0.00	0.00	0.00	0.25	0.25
2.04	0.00	0.00	0.00	0.25	0.25
2.09	0.00	0.00	0.00	0.25	0.25
2.14	0.00	0.00	0.00	0.25	0.25
2.19	0.00	0.00	0.00	0.25	0.25
2.24	0.00	0.00	0.00	0.25	0.25
2.29	0.00	0.00	0.00	0.25	0.25
2.34	0.00	0.00	0.00	0.25	0.25
2.39	0.00	0.00	0.00	0.25	0.25
2.44	0.00	0.00	0.00	0.25	0.25
2.49	0.00	0.00	0.00	0.25	0.25
2.54	0.00	0.00	0.00	0.25	0.25
2.59	0.00	0.00	0.00	0.25	0.25
2.64	0.00	0.00	0.00	0.25	0.25
2.69	0.00	0.00	0.00	0.25	0.25
2.74	0.00	0.00	0.00	0.25	0.25
2.79	0.00	0.00	0.00	0.25	0.25
2.84	0.00	0.00	0.00	0.25	0.25
2.89	0.00	0.00	0.00	0.25	0.25
2.94	0.00	0.00	0.00	0.25	0.25
2.99	0.00	0.00	0.00	0.25	0.25
3.04	0.00	0.00	0.00	0.25	0.25
3.09	0.00	0.00	0.00	0.25	0.25
3.14	0.00	0.00	0.00	0.25	0.25
3.19	0.00	0.00	0.00	0.25	0.25
3.24	0.00	0.00	0.00	0.25	0.25
3.29	0.00	0.00	0.00	0.25	0.25
3.34	0.00	0.00	0.00	0.25	0.25
3.39	0.00	0.00	0.00	0.25	0.25
3.44	0.00	0.00	0.00	0.25	0.25
3.49	0.00	0.00	0.00	0.25	0.25
3.54	0.00	0.00	0.00	0.25	0.25
3.59	0.00	0.00	0.00	0.25	0.25
3.64	0.00	0.00	0.00	0.25	0.25
3.69	0.00	0.00	0.00	0.25	0.25
3.74	0.00	0.00	0.00	0.25	0.25
3.79	0.00	0.00	0.00	0.25	0.25
3.84	0.00	0.00	0.00	0.25	0.25
3.89	0.00	0.00	0.00	0.25	0.25
3.94	0.00	0.00	0.00	0.25	0.25
3.99	0.00	0.00	0.00	0.25	0.25

Sediment Basin # 6 Colon

Qp = 93.60 cfs
 Tp = 28.75 minutes
 dT = Max of 2 minutes
 or 1.0% of increment to peak

Phase 1
 10 - year Storm Event

b = 1.2
 K_s = 29,092

Number of Riser/Barrel Assemblies = 1
 Diameter of Barrel = 12 (in)
 Height of Riser above barrel = 4.0 (ft)
 Height of Riser from bottom of barrel = 5.0 (ft) elevation 254.00
 Emergency Spillway = 6.1 (ft) elevation 255.10
 Total Height of Dam = 7.0 (ft) elevation 256.00
 Length of Emergency Spillway = 10 (ft)
 Diameter of Riser = 18 (in)
 Permanent Pond Stage = 0 (ft) elevation 249.0

4.0E-03 Settling Velocity of design particle (fps)
 2 Effective number of cells (2 is construction site #)
 100% Minimum Settling Efficiency
 5.4 ft Maximum Stage 254.36 msl elevation
 3.6 cfs Peak outflow
 3.6 cfs Peak Riser/Barrel outflow
 0.0 cfs Peak Weir flow

Notes:

1. Length of emergency spillway is the bottom width of the emergency spillway.
2. Settling efficiency neglects permanent pond volume

TIME	INFLOW	STORAGE	STAGE	Skimmer	RISER	WEIR	BARREL	TOTAL	Bound	Estimated	Settling
(min)	[cfs]	[cu ft]	[ft]	Flow [cfs]	CAPACIT	FLOW	CAPACITY	OUTFLOW	Discharge	Surface	Efficiency
					Y [cfs]	[cfs]	[cfs]	[cfs]	[cfs]	Area (sf)	[%]
0	0.0	0	0.0	0.00	0.00	0.00	0.00	0.00	0.00	-	N/A
2	1.1	0	0.0	0.00	0.00	0.00	0.00	0.00	0.00	-	N/A
4	4.4	134	0.0	0.00	0.00	0.00	0.00	0.00	32.33	14,693	N/A
6	9.7	662	0.0	0.00	0.00	0.00	0.00	0.00	41.69	18,952	N/A
8	16.8	1,826	0.1	0.00	0.00	0.00	0.00	0.00	49.00	22,273	N/A
10	25.3	3,839	0.2	0.00	0.00	0.00	0.00	0.00	55.15	25,068	N/A
12	34.8	6,872	0.3	0.00	0.00	0.00	0.00	0.00	60.50	27,500	N/A
14	44.9	11,048	0.4	0.25	0.25	0.00	0.25	0.25	65.25	29,657	100%
16	55.1	16,405	0.6	0.25	0.25	0.00	0.25	0.25	69.48	31,582	100%
18	64.9	22,984	0.8	0.25	0.25	0.00	0.25	0.25	73.31	33,322	100%
20	73.8	30,738	1.0	0.25	0.25	0.00	0.25	0.25	76.78	34,900	100%
22	81.4	39,564	1.3	0.25	0.25	0.00	0.25	0.25	79.92	36,329	100%
24	87.4	49,307	1.6	0.25	0.25	0.00	0.25	0.25	82.77	37,624	100%
26	91.5	59,770	1.8	0.25	0.25	0.00	0.25	0.25	85.35	38,794	100%
28	93.4	70,721	2.1	0.25	0.25	0.00	0.25	0.25	87.66	39,846	100%
30	93.2	81,905	2.4	0.25	0.25	0.00	0.25	0.25	89.73	40,787	100%
32	90.7	93,054	2.7	0.25	0.25	0.00	0.25	0.25	91.57	41,624	100%
34	86.1	103,905	2.9	0.25	0.25	0.00	0.25	0.25	93.19	42,361	100%
36	79.8	114,207	3.2	0.25	0.25	0.00	0.25	0.25	94.61	43,003	100%
38	72.9	123,747	3.4	0.25	0.25	0.00	0.25	0.25	95.82	43,555	100%
40	66.6	132,460	3.6	0.25	0.25	0.00	0.25	0.25	96.86	44,029	100%
42	60.8	140,417	3.8	0.25	0.25	0.00	0.25	0.25	97.77	44,439	100%
44	55.5	147,683	3.9	0.25	0.25	0.00	0.25	0.25	98.55	44,797	100%
46	50.7	154,318	4.1	0.25	0.25	0.00	0.25	0.25	99.25	45,112	100%
48	46.4	160,377	4.2	0.25	0.25	0.00	0.25	0.25	99.86	45,389	100%
50	42.3	165,910	4.3	0.25	0.25	0.00	0.25	0.25	100.40	45,634	100%
52	38.7	170,961	4.4	0.25	0.25	0.00	0.25	0.25	100.88	45,853	100%
54	35.3	175,573	4.5	0.25	0.25	0.00	0.25	0.25	101.30	46,047	100%
56	32.3	179,784	4.6	0.25	0.25	0.00	0.25	0.25	101.69	46,221	100%
58	29.5	183,627	4.7	0.25	0.25	0.00	0.25	0.25	102.03	46,377	100%
60	26.9	187,136	4.8	0.25	0.25	0.00	0.25	0.25	102.34	46,517	100%
62	24.6	190,339	4.9	0.25	0.25	0.00	0.25	0.25	102.61	46,643	100%
64	22.5	193,263	4.9	0.25	0.25	0.00	0.25	0.25	102.86	46,756	100%
66	20.5	195,931	5.0	0.25	0.25	0.00	0.25	0.25	103.09	46,858	100%
68	18.8	198,365	5.0	0.25	0.31	0.00	8.03	0.31	103.29	46,950	100%
70	17.1	200,580	5.1	0.25	0.55	0.00	8.07	0.55	103.47	47,033	100%
72	15.7	202,571	5.1	0.25	0.84	0.00	8.11	0.84	103.64	47,107	100%
74	14.3	204,349	5.2	0.25	1.16	0.00	8.14	1.16	103.78	47,172	100%
76	13.1	205,925	5.2	0.25	1.48	0.00	8.17	1.48	103.91	47,230	100%
78	11.9	207,315	5.2	0.25	1.79	0.00	8.20	1.79	104.02	47,281	100%
80	10.9	208,533	5.2	0.25	2.08	0.00	8.22	2.08	104.11	47,325	100%
82	10.0	209,592	5.3	0.25	2.34	0.00	8.24	2.34	104.20	47,363	100%

84	9.1	210,507	5.3	0.25	2.57	0.00	8.26	2.57	104.27	47,396	100%
86	8.3	211,290	5.3	0.25	2.78	0.00	8.27	2.78	104.33	47,424	100%
88	7.6	211,954	5.3	0.25	2.96	0.00	8.28	2.96	104.38	47,447	100%
90	6.9	212,510	5.3	0.25	3.11	0.00	8.29	3.11	104.43	47,467	100%
92	6.3	212,969	5.3	0.25	3.24	0.00	8.30	3.24	104.46	47,484	100%
94	5.8	213,340	5.3	0.25	3.35	0.00	8.31	3.35	104.49	47,497	100%
96	5.3	213,633	5.3	0.25	3.43	0.00	8.31	3.43	104.52	47,507	100%
98	4.8	213,855	5.4	0.25	3.50	0.00	8.32	3.50	104.53	47,515	100%
100	4.4	214,015	5.4	0.25	3.55	0.00	8.32	3.55	104.55	47,521	100%
102	4.0	214,119	5.4	0.25	3.58	0.00	8.32	3.58	104.55	47,524	100%
104	3.7	214,174	5.4	0.25	3.59	0.00	8.32	3.59	104.56	47,526	100%
106	3.4	214,185	5.4	0.25	3.60	0.00	8.32	3.60	104.56	47,527	100%
108	3.1	214,157	5.4	0.25	3.59	0.00	8.32	3.59	104.56	47,526	100%
110	2.8	214,096	5.4	0.25	3.57	0.00	8.32	3.57	104.55	47,523	100%
112	2.6	214,004	5.4	0.25	3.54	0.00	8.32	3.54	104.54	47,520	100%
114	2.3	213,887	5.4	0.25	3.51	0.00	8.32	3.51	104.54	47,516	100%
116	2.1	213,747	5.3	0.25	3.47	0.00	8.31	3.47	104.52	47,511	100%
118	2.0	213,588	5.3	0.25	3.42	0.00	8.31	3.42	104.51	47,505	100%
120	1.8	213,412	5.3	0.25	3.37	0.00	8.31	3.37	104.50	47,499	100%
122	1.6	213,222	5.3	0.25	3.32	0.00	8.31	3.32	104.48	47,493	100%
124	1.5	213,020	5.3	0.25	3.26	0.00	8.30	3.26	104.47	47,485	100%
126	1.4	212,808	5.3	0.25	3.20	0.00	8.30	3.20	104.45	47,478	100%
128	1.2	212,588	5.3	0.25	3.14	0.00	8.29	3.14	104.43	47,470	100%
130	1.1	212,360	5.3	0.25	3.07	0.00	8.29	3.07	104.42	47,462	100%
132	1.0	212,128	5.3	0.25	3.01	0.00	8.29	3.01	104.40	47,454	100%
134	0.9	211,892	5.3	0.25	2.94	0.00	8.28	2.94	104.38	47,445	100%
136	0.9	211,652	5.3	0.25	2.88	0.00	8.28	2.88	104.36	47,437	100%
138	0.8	211,411	5.3	0.25	2.81	0.00	8.27	2.81	104.34	47,428	100%
140	0.7	211,168	5.3	0.25	2.75	0.00	8.27	2.75	104.32	47,419	100%
142	0.7	210,925	5.3	0.25	2.68	0.00	8.26	2.68	104.30	47,411	100%
144	0.6	210,683	5.3	0.25	2.62	0.00	8.26	2.62	104.28	47,402	100%
146	0.6	210,441	5.3	0.25	2.56	0.00	8.26	2.56	104.27	47,393	100%
148	0.5	210,200	5.3	0.25	2.49	0.00	8.25	2.49	104.25	47,385	100%
150	0.5	209,962	5.3	0.25	2.43	0.00	8.25	2.43	104.23	47,376	100%
152	0.4	209,725	5.3	0.25	2.37	0.00	8.24	2.37	104.21	47,368	100%
154	0.4	209,491	5.3	0.25	2.31	0.00	8.24	2.31	104.19	47,359	100%
156	0.4	209,259	5.3	0.25	2.25	0.00	8.23	2.25	104.17	47,351	100%
158	0.3	209,031	5.3	0.25	2.20	0.00	8.23	2.20	104.15	47,343	100%
160	0.3	208,806	5.2	0.25	2.14	0.00	8.23	2.14	104.14	47,335	100%
162	0.3	208,584	5.2	0.25	2.09	0.00	8.22	2.09	104.12	47,327	100%
164	0.2	208,365	5.2	0.25	2.04	0.00	8.22	2.04	104.10	47,319	100%
166	0.2	208,150	5.2	0.25	1.98	0.00	8.21	1.98	104.08	47,311	100%
168	0.2	207,939	5.2	0.25	1.93	0.00	8.21	1.93	104.07	47,303	100%
170	0.2	207,731	5.2	0.25	1.89	0.00	8.21	1.89	104.05	47,296	100%
172	0.2	207,527	5.2	0.25	1.84	0.00	8.20	1.84	104.03	47,288	100%
174	0.2	207,327	5.2	0.25	1.79	0.00	8.20	1.79	104.02	47,281	100%
176	0.1	207,130	5.2	0.25	1.75	0.00	8.19	1.75	104.00	47,274	100%
178	0.1	206,937	5.2	0.25	1.70	0.00	8.19	1.70	103.99	47,267	100%
180	0.1	206,748	5.2	0.25	1.66	0.00	8.19	1.66	103.97	47,260	100%
182	0.1	206,563	5.2	0.25	1.62	0.00	8.18	1.62	103.96	47,253	100%
184	0.1	206,381	5.2	0.25	1.58	0.00	8.18	1.58	103.94	47,247	100%
186	0.1	206,203	5.2	0.25	1.54	0.00	8.18	1.54	103.93	47,240	100%
188	0.1	206,029	5.2	0.25	1.51	0.00	8.17	1.51	103.91	47,234	100%
190	0.1	205,858	5.2	0.25	1.47	0.00	8.17	1.47	103.90	47,228	100%
192	0.1	205,691	5.2	0.25	1.43	0.00	8.17	1.43	103.89	47,222	100%
194	0.1	205,527	5.2	0.25	1.40	0.00	8.16	1.40	103.87	47,216	100%
196	0.1	205,366	5.2	0.25	1.37	0.00	8.16	1.37	103.86	47,210	100%
198	0.1	205,209	5.2	0.25	1.34	0.00	8.16	1.34	103.85	47,204	100%
200	0.0	205,055	5.2	0.25	1.30	0.00	8.16	1.30	103.84	47,198	100%
202	0.0	204,905	5.2	0.25	1.27	0.00	8.15	1.27	103.82	47,193	100%
204	0.0	204,757	5.2	0.25	1.24	0.00	8.15	1.24	103.81	47,187	100%
206	0.0	204,612	5.2	0.25	1.22	0.00	8.15	1.22	103.80	47,182	100%

**Sediment Basin #6 Colon Mine Phase 1 Hydrograph
10-Yr Storm**

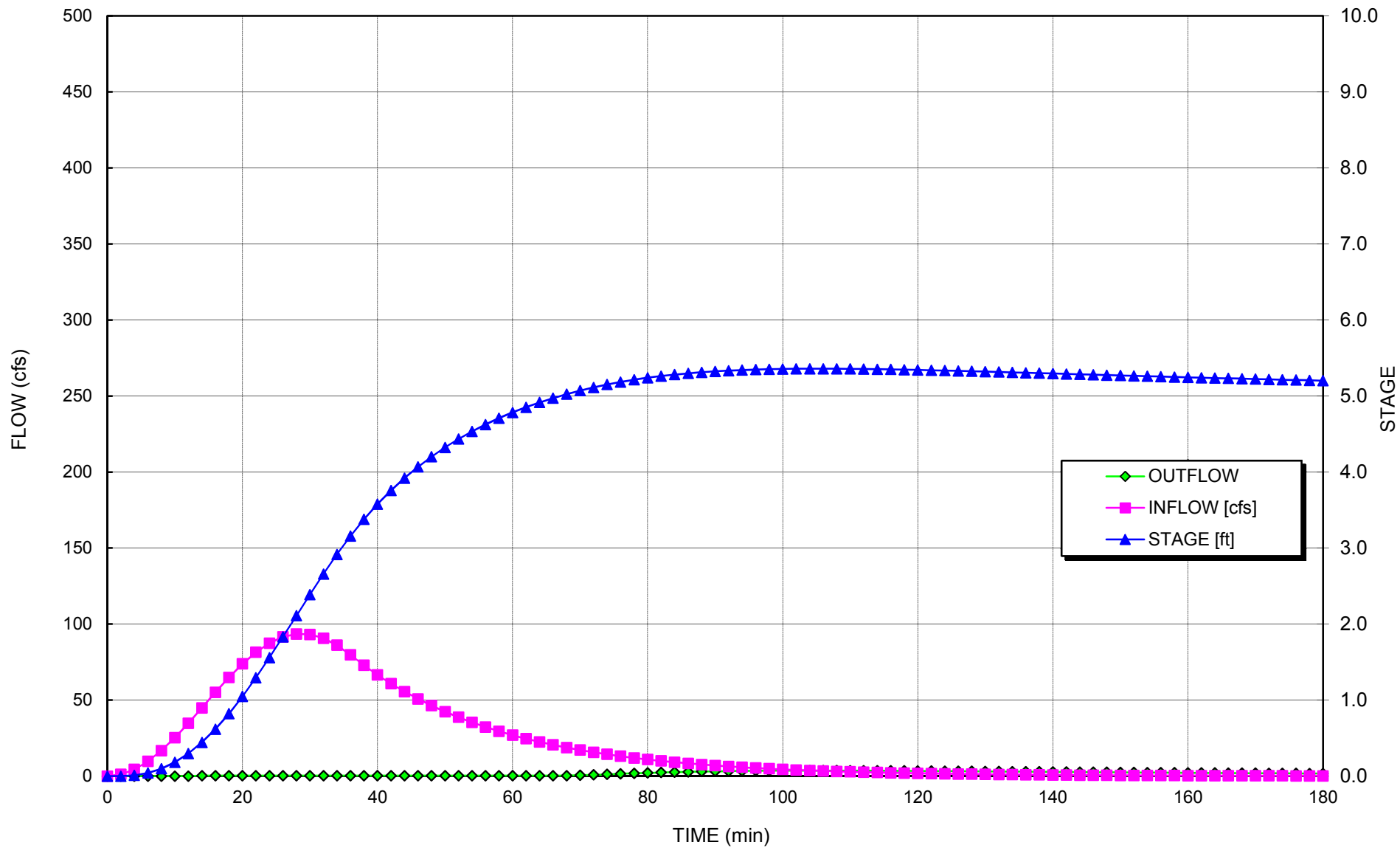

This page intentionally left blank.

Sediment Basin # 6 Colon

Qp = 114.53 cfs
 Tp = 29.11 minutes
 dT = Max of 2 minutes
 or 1.0% of increment to peak

Phase 1
 25 - year Storm Event

b = 1.2
 K_s = 29,092

Number of Riser/Barrel Assemblies = 1
 Diameter of Barrel = 12 (in)
 Height of Riser above barrel = 4 (ft)
 Height of Riser from bottom of barrel = 5 (ft) elevation 254.00
 Emergency Spillway = 6.1 (ft) elevation 255.10
 Total Height of Dam = 7 (ft) elevation 256.00
 Length of Emergency Spillway = 10 (ft)
 Diameter of Riser = 18 (in)
 Permanent Pond Stage = 0 (ft) elevation 249.0

4.0E-03 Settling Velocity of design particle (fps)
 2 Effective number of cells (2 is construction site #)
 99% Minimum Settling Efficiency
 6.1 ft Maximum Stage 255.06 msl elevation
 8.9 cfs Peak outflow
 8.9 cfs Peak Riser/Barrel outflow
 0.0 cfs Peak Weir flow

Notes:

1. Length of emergency spillway is the bottom width of the emergency spillway.
2. Settling efficiency neglects permanent pond volume

TIME	INFLOW	STORAGE	STAGE	Skimmer	RISER	WEIR	BARREL	TOTAL	Bound	Estimated	Settling
(min)	[cfs]	[cu ft]	[ft]	Flow [cfs]	CAPACIT	FLOW	CAPACITY	OUTFLOW	Discharge	Surface	Efficiency
					Y [cfs]	[cfs]	[cfs]	[cfs]	[cfs]	Area (sf)	[%]
0	0.0	0	0.0	0.00	0.00	0.00	0.00	0.00	0.00	-	N/A
2	1.3	0	0.0	0.00	0.00	0.00	0.00	0.00	0.00	-	N/A
4	5.3	159	0.0	0.00	0.00	0.00	0.00	0.00	33.25	15,112	N/A
6	11.6	790	0.0	0.00	0.00	0.00	0.00	0.00	42.88	19,492	N/A
8	20.0	2,180	0.1	0.00	0.00	0.00	0.00	0.00	50.40	22,910	N/A
10	30.2	4,586	0.2	0.00	0.00	0.00	0.00	0.00	56.73	25,786	N/A
12	41.7	8,213	0.3	0.25	0.25	0.00	0.25	0.25	62.24	28,291	100%
14	53.8	13,183	0.5	0.25	0.25	0.00	0.25	0.25	67.11	30,503	100%
16	66.1	19,613	0.7	0.25	0.25	0.00	0.25	0.25	71.48	32,492	100%
18	78.1	27,521	1.0	0.25	0.25	0.00	0.25	0.25	75.44	34,291	100%
20	89.0	36,858	1.2	0.25	0.25	0.00	0.25	0.25	79.03	35,922	100%
22	98.5	47,508	1.5	0.25	0.25	0.00	0.25	0.25	82.29	37,402	100%
24	106.0	59,295	1.8	0.25	0.25	0.00	0.25	0.25	85.24	38,745	100%
26	111.3	71,989	2.1	0.25	0.25	0.00	0.25	0.25	87.91	39,959	100%
28	114.1	85,318	2.5	0.25	0.25	0.00	0.25	0.25	90.32	41,053	100%
30	114.3	98,983	2.8	0.25	0.25	0.00	0.25	0.25	92.48	42,035	100%
32	111.8	112,665	3.1	0.25	0.25	0.00	0.25	0.25	94.40	42,910	100%
34	106.8	126,048	3.4	0.25	0.25	0.00	0.25	0.25	96.10	43,683	100%
36	99.4	138,828	3.7	0.25	0.25	0.00	0.25	0.25	97.59	44,359	100%
38	91.1	150,730	4.0	0.25	0.25	0.00	0.25	0.25	98.87	44,943	100%
40	83.3	161,632	4.2	0.25	0.25	0.00	0.25	0.25	99.98	45,445	100%
42	76.2	171,599	4.4	0.25	0.25	0.00	0.25	0.25	100.94	45,880	100%
44	69.7	180,713	4.6	0.25	0.25	0.00	0.25	0.25	101.77	46,259	100%
46	63.7	189,045	4.8	0.25	0.25	0.00	0.25	0.25	102.50	46,592	100%
48	58.3	196,663	5.0	0.25	0.25	0.00	0.25	0.25	103.15	46,886	100%
50	53.3	203,627	5.1	0.25	1.03	0.00	8.13	1.03	103.72	47,146	100%
52	48.8	209,900	5.3	0.25	2.42	0.00	8.25	2.42	104.22	47,374	100%
54	44.6	215,461	5.4	0.25	3.98	0.00	8.35	3.98	104.66	47,571	100%
56	40.8	220,334	5.5	0.25	5.55	0.00	8.43	5.55	105.03	47,741	100%
58	37.3	224,561	5.6	0.25	7.06	0.00	8.51	7.06	105.35	47,886	100%
60	34.1	228,189	5.7	0.25	8.44	0.00	8.57	8.44	105.62	48,008	99%
62	31.2	231,269	5.7	0.25	9.68	0.00	8.62	8.62	105.84	48,110	99%
64	28.5	233,977	5.8	0.25	10.81	0.00	8.67	8.67	106.04	48,199	99%
66	26.1	236,360	5.8	0.25	11.84	0.00	8.71	8.71	106.21	48,277	99%
68	23.9	238,446	5.9	0.25	12.76	0.00	8.75	8.75	106.36	48,345	99%
70	21.8	240,260	5.9	0.25	13.59	0.00	8.78	8.78	106.49	48,403	99%
72	20.0	241,826	5.9	0.25	14.31	0.00	8.80	8.80	106.60	48,453	99%
74	18.3	243,165	6.0	0.25	14.94	0.00	8.82	8.82	106.69	48,496	99%
76	16.7	244,296	6.0	0.25	15.47	0.00	8.84	8.84	106.77	48,532	99%
78	15.3	245,238	6.0	0.25	15.93	0.00	8.86	8.86	106.83	48,561	99%
80	14.0	246,007	6.0	0.25	16.30	0.00	8.87	8.87	106.89	48,585	99%
82	12.8	246,618	6.0	0.25	16.59	0.00	8.88	8.88	106.93	48,605	99%

84	11.7	247,085	6.0	0.25	16.82	0.00	8.89	8.89	106.96	48,619	99%
86	10.7	247,420	6.1	0.25	16.99	0.00	8.90	8.90	106.99	48,630	99%
88	9.8	247,634	6.1	0.25	17.09	0.00	8.90	8.90	107.00	48,636	99%
90	8.9	247,739	6.1	0.25	17.14	0.00	8.90	8.90	107.01	48,640	99%
92	8.2	247,743	6.1	0.25	17.15	0.00	8.90	8.90	107.01	48,640	99%
94	7.5	247,655	6.1	0.25	17.10	0.00	8.90	8.90	107.00	48,637	99%
96	6.8	247,484	6.1	0.25	17.02	0.00	8.90	8.90	106.99	48,632	99%
98	6.3	247,237	6.0	0.25	16.90	0.00	8.89	8.89	106.97	48,624	99%
100	5.7	246,920	6.0	0.25	16.74	0.00	8.89	8.89	106.95	48,614	99%
102	5.2	246,540	6.0	0.25	16.56	0.00	8.88	8.88	106.92	48,602	99%
104	4.8	246,101	6.0	0.25	16.34	0.00	8.87	8.87	106.89	48,588	99%
106	4.4	245,610	6.0	0.25	16.10	0.00	8.87	8.87	106.86	48,573	99%
108	4.0	245,071	6.0	0.25	15.84	0.00	8.86	8.86	106.82	48,556	99%
110	3.7	244,488	6.0	0.25	15.57	0.00	8.85	8.85	106.78	48,538	99%
112	3.3	243,866	6.0	0.25	15.27	0.00	8.84	8.84	106.74	48,518	99%
114	3.1	243,207	6.0	0.25	14.96	0.00	8.83	8.83	106.69	48,497	99%
116	2.8	242,515	5.9	0.25	14.63	0.00	8.81	8.81	106.65	48,475	99%
118	2.6	241,793	5.9	0.25	14.29	0.00	8.80	8.80	106.59	48,452	99%
120	2.3	241,044	5.9	0.25	13.95	0.00	8.79	8.79	106.54	48,428	99%
122	2.1	240,270	5.9	0.25	13.59	0.00	8.78	8.78	106.49	48,403	99%
124	2.0	239,474	5.9	0.25	13.23	0.00	8.76	8.76	106.43	48,378	99%
126	1.8	238,657	5.9	0.25	12.86	0.00	8.75	8.75	106.37	48,352	99%
128	1.6	237,822	5.9	0.25	12.48	0.00	8.74	8.74	106.31	48,325	99%
130	1.5	236,970	5.8	0.25	12.11	0.00	8.72	8.72	106.25	48,297	99%
132	1.4	236,104	5.8	0.25	11.73	0.00	8.71	8.71	106.19	48,269	99%
134	1.3	235,223	5.8	0.25	11.34	0.00	8.69	8.69	106.13	48,240	99%
136	1.1	234,331	5.8	0.25	10.96	0.00	8.68	8.68	106.06	48,211	99%
138	1.0	233,427	5.8	0.25	10.58	0.00	8.66	8.66	106.00	48,181	99%
140	1.0	232,513	5.7	0.25	10.19	0.00	8.64	8.64	105.93	48,151	99%
142	0.9	231,591	5.7	0.25	9.81	0.00	8.63	8.63	105.87	48,121	99%
144	0.8	230,661	5.7	0.25	9.43	0.00	8.61	8.61	105.80	48,090	99%
146	0.7	229,723	5.7	0.25	9.05	0.00	8.60	8.60	105.73	48,059	99%
148	0.7	228,780	5.7	0.25	8.67	0.00	8.58	8.58	105.66	48,028	99%
150	0.6	227,830	5.6	0.25	8.30	0.00	8.56	8.30	105.59	47,996	99%
152	0.6	226,908	5.6	0.25	7.94	0.00	8.55	7.94	105.52	47,965	99%
154	0.5	226,022	5.6	0.25	7.61	0.00	8.53	7.61	105.46	47,935	99%
156	0.5	225,171	5.6	0.25	7.28	0.00	8.52	7.28	105.39	47,906	100%
158	0.4	224,353	5.6	0.25	6.98	0.00	8.50	6.98	105.33	47,879	100%
160	0.4	223,567	5.6	0.25	6.69	0.00	8.49	6.69	105.27	47,852	100%
162	0.4	222,811	5.5	0.25	6.42	0.00	8.48	6.42	105.22	47,826	100%
164	0.3	222,083	5.5	0.25	6.16	0.00	8.46	6.16	105.16	47,801	100%
166	0.3	221,383	5.5	0.25	5.92	0.00	8.45	5.92	105.11	47,777	100%
168	0.3	220,709	5.5	0.25	5.68	0.00	8.44	5.68	105.06	47,754	100%
170	0.3	220,061	5.5	0.25	5.46	0.00	8.43	5.46	105.01	47,732	100%
172	0.2	219,435	5.5	0.25	5.25	0.00	8.42	5.25	104.96	47,710	100%
174	0.2	218,833	5.5	0.25	5.05	0.00	8.41	5.05	104.92	47,689	100%
176	0.2	218,252	5.4	0.25	4.86	0.00	8.40	4.86	104.87	47,669	100%
178	0.2	217,692	5.4	0.25	4.68	0.00	8.39	4.68	104.83	47,650	100%
180	0.2	217,152	5.4	0.25	4.50	0.00	8.38	4.50	104.79	47,631	100%
182	0.1	216,631	5.4	0.25	4.34	0.00	8.37	4.34	104.75	47,612	100%
184	0.1	216,128	5.4	0.25	4.18	0.00	8.36	4.18	104.71	47,595	100%
186	0.1	215,642	5.4	0.25	4.03	0.00	8.35	4.03	104.67	47,578	100%
188	0.1	215,173	5.4	0.25	3.89	0.00	8.34	3.89	104.63	47,561	100%
190	0.1	214,720	5.4	0.25	3.75	0.00	8.33	3.75	104.60	47,545	100%
192	0.1	214,281	5.4	0.25	3.62	0.00	8.32	3.62	104.57	47,530	100%
194	0.1	213,858	5.4	0.25	3.50	0.00	8.32	3.50	104.53	47,515	100%
196	0.1	213,448	5.3	0.25	3.38	0.00	8.31	3.38	104.50	47,501	100%
198	0.1	213,052	5.3	0.25	3.27	0.00	8.30	3.27	104.47	47,486	100%
200	0.1	212,668	5.3	0.25	3.16	0.00	8.30	3.16	104.44	47,473	100%
202	0.1	212,297	5.3	0.25	3.06	0.00	8.29	3.06	104.41	47,460	100%
204	0.1	211,938	5.3	0.25	2.96	0.00	8.28	2.96	104.38	47,447	100%
206	0.1	211,590	5.3	0.25	2.86	0.00	8.28	2.86	104.36	47,434	100%

**Sediment Basin #6 Colon Mine Phase 1 Hydrograph
25-Yr Storm**

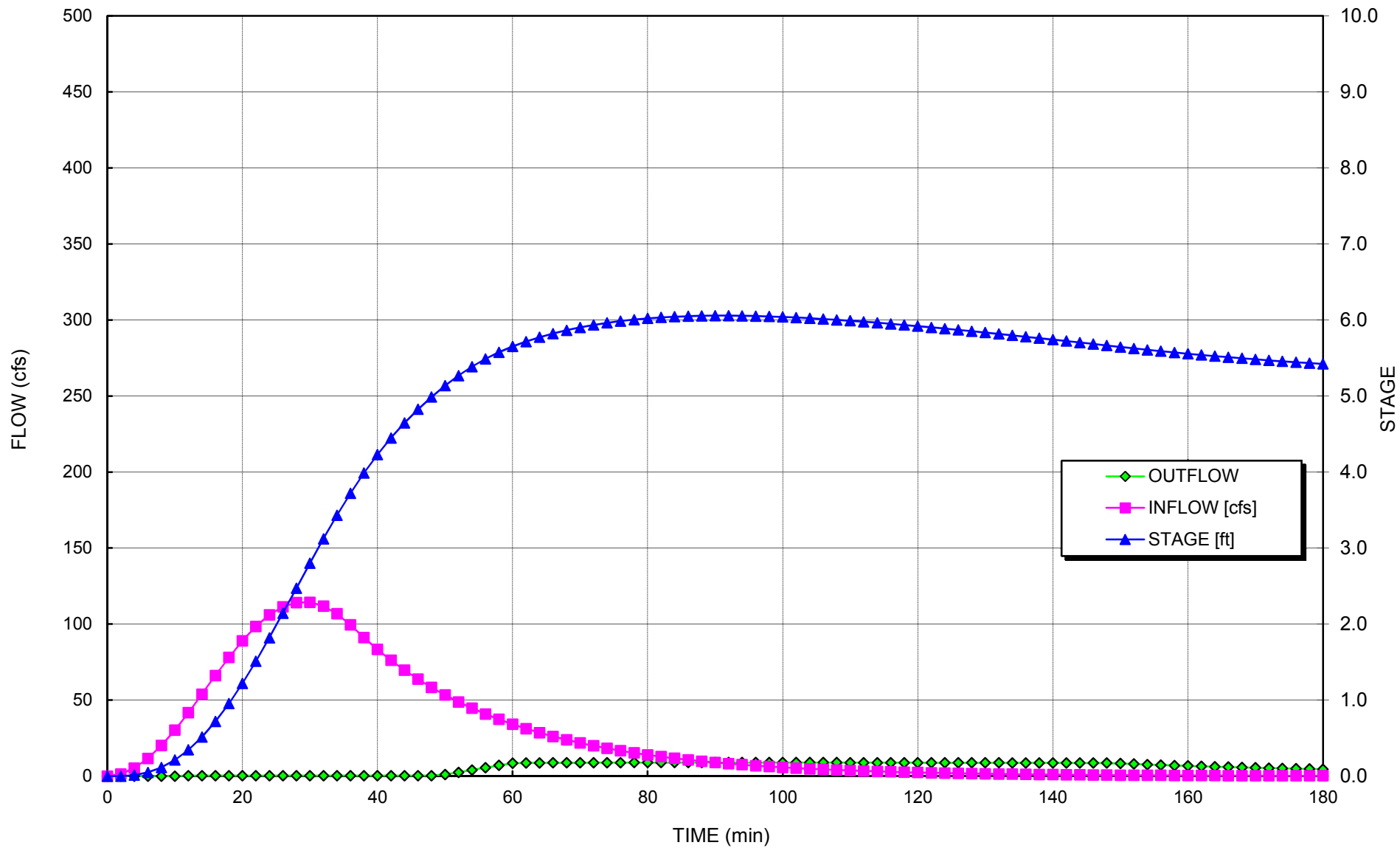

This page intentionally left blank.

Project:	Charah Colon Mine	Computed:	EAW	Date:	1/4/15
Subject:	Permit Application	Checked:	PAW	Date:	1/4/15
Task:	Sediment Basin #7	Sheet:	1	Of:	4

Objective Design the sediment basin to contain the 10-year storm and pass the 100-year storm without over topping the berm.

References

1. NC Erosion and Sediment Control Planning and Design Manual.
2. "Elements of Urban Stormwater Design" by H. Rooney Malcom, P.E.
3. VA Erosion and Sediment Control Handbook
3. NOAA Atlas 14, Volume 2, Version 3

Given

	Phase	1	2	2	2		
	Storm Event (yrs) =	10	10	25	100		
	Total Drainage Area A (ac) =	16.4	33.1	33.1	33.1		
	Disturbed Area (ac) =	12.5	29.3	29.3	29.3		
	Curve Number CN =	82	81	81	81	Hydrographs	
	Rainfall Depth P (in) =	5.28	5.28	6.28	7.88	(24-hr rainfall)	Ref 3
	Peak Flow Q _p (cfs) =	85.59	134.71	171.36	230.40	Hydrographs	

Design Criteria

Required sediment storage	1,800	cf / acre of drainage
Required sediment storage	59,580	cf (based on largest Phase)
Required Surface Area	435	sf/cfs of the 10-yr storm peak flow (based on the largest Phase in cfs)
Required Surface Area (SF)	58,599	of the 10-yr storm peak flow (based on the largest Phase)

Determine Shape of Basin:

Measure the area of the Basin using AutoCADD.

Calculate Volume of the Basin using Truncated Pyramid Method.

Shape factor used in hydrographs basin depth may be greater than indicated below

Elevation (ft)	Depth (ft)	Area (sf)	Volume (cf)	Cumulative Vol (cf)	Cumulative Vol (cy)
238	0	49,034	0	0	0
239	1	52,537	50,775	50,775	1,881
240	2	56,098	54,308	105,083	3,892
241	3	59,717	57,898	162,981	6,036
242	4	63,393	61,546	224,527	8,316
243	5	67,128	65,252	289,779	10,733
244	6	70,920	69,015	358,794	13,289

Design Sediment Depth (ft) = 3

Sediment Storage (cf) = 162,981

Required Sediment Storage Achieved

Design Surface Area Depth (ft) = 3

Surface Area (sf) = 59,717

Required Surface Area Achieved

Project:	Charah Colon Mine	Computed:	EAW	Date:	1/4/15
Subject:	Permit Application	Checked:	PAW	Date:	1/4/15
Task:	Sediment Basin #7	Sheet:	2	Of:	4

Select Skimmer

A. R. Jarrett Method

$$D = [Q / (2,310 * (H^{0.5}))]^{0.5}$$

D = Diameter of Orifice (inches)
 Q = Dewater Rate (cf/day)
 H = Head on orifice, varies based on skimmer size (ft)

Skimmer Sizes (Inches)	Head (ft)
1.5	0.125
2	0.167
2.5	0.167
3	0.250
4	0.333
5	0.333
6	0.417
8	0.500

Volume to Dewater (cf) =	162,981		
Number of Skimmers	2		
Days to Drain =	5	<i>assumed</i>	
Q each (cf/day) =	16,298		0.19 cfs
Selected Skimmer Size (inches) =	4		
Head on Skimmer (feet) =	0.333		
Diameter of Orifice (inches) =	3.5		

Route the flow through the Basin

Riser is not perforated, but skimmer is attached.

$$S = (1000/CN) - 10$$

$$\text{Runoff Depth } Q^* \text{ (inches)} = (P-0.2S)^2 / (P+0.8S)$$

$$T_p \text{ (min)} = 60.5(Q^*)A/Q_p / 1.39$$

Ref 2, III-4

Phase	1	2	2	2
Storm Event (yrs) =	10	10	25	100
S =	2.20	2.35	2.35	2.35
Runoff Depth Q* (inches) =	3.33	3.23	4.14	5.63
Time to Peak T _p (min) =	27.78	34.59	34.80	35.20

Determine Pond Storage Elevation (Z_{water}):

Pick one point near max expected water surface and the other at the mid depth.

$$Z_1 \text{ (ft)} = 3 \quad S_1 \text{ (cf)} = 162,981$$

$$Z_2 \text{ (ft)} = 6 \quad S_2 \text{ (cf)} = 358,794$$

$$b = \ln(S_2/S_1) / \ln(Z_2/Z_1) = 1.1$$

$$K_S = S_2 / Z_2^b = 46,662$$

Ref 2, III-8

Project: Charah Colon Mine	Computed: EAW	Date: 1/4/15
Subject: Permit Application	Checked: PAW	Date: 1/4/15
Task: Sediment Basin #7	Sheet: 3	Of: 4

Determine Settling Velocity

Conversion Factor = 3.281 ft/sec per m/sec
 Gravitational Acceleration, g (m/s^2) = 9.81
 Specific Gravity of soil (s_s) = 2.6
 Kinematic Viscosity of water (ν) = 1.14E-06 m^2 / sec @ 20°C Ref 2, IV-11
 Diameter of the Design Particle d_{15} = 40.00E-06 m

Design Particle Settling Velocity = $(g / 18) * [(s_s - 1) / \nu] d^2 = 4.02E-03$ ft/sec

Route the Storm through the Basin using the Hydrograph Model

Set Height of Emergency Spillway at (ft) = 6.90 *See Hydrograph*
 Set Top of Dam at (ft) = 7.50

Emergency Spillway

Q_E (cfs) = 100-Yr Storm
 Q_E (cfs) = 21.1
 Cross Section = Trapezoid
 Channel Side Slope (z) = 5 (enter X for X:1)
 n = 0.03 Grass Lined
 V_p (ft/sec) = 5.0 Permissible Velocity for lining Ref 2, II-7
 Allowable Shear Stress (psf) = 2.0 Allowable Shear Stress for lining
 Bottom Width, b (ft) = 20

Calculate Required Depth of Spillway:

Normal-Depth Procedure

$AR^{2/3} = Qn / 1.49s^{0.5}$ $Q = VA$
 $Z_{req} = Qn / 1.49s^{0.5}$ Area (A) = $bd + z(d^2)$
 $Z_{av} = AR^{2/3}$ $R = Area / (b + 2d((z^2 + 1)^{.5}))$
 Avg Shear Stress (T) = $K_b * d * s$ * unit weight of water

Channel Slope ft/ft	Depth, d (ft)	A (sf)	Z_{req}	R	Z_{avail}	V (ft/sec)	T (psf)
0.01	0.39	8.50	4.26	0.35	4.26	2.5	0.2
0.02	0.32	6.82	3.01	0.29	3.01	3.1	0.4

Construct the channel to be : 20 ft, Bottom Width (measured at top of lining)
 0.6 ft, depth (measured at top of lining)
 1% slope

Anti-Seep Collar:

Anti-Seep Collar Size = 2 * Barrel Dia
 Anti-Seep Collar Size (ft) = 4
 Use Anti-Seep Collar Size (ft) = 4 x 4

Project: Charah Colon Mine	Computed: EAW	Date: 1/4/15
Subject: Permit Application	Checked: PAW	Date: 1/4/15
Task: Sediment Basin #7	Sheet: 4	Of: 4

Minimum Concrete Base for Riser:

Diameter of Riser (in) = 60 From Hydrograph
 Avg Density of Concrete (lbs/cf) = 87.6
 Density of Water (lbs/cf) = 62.4
 Riser Displacement (cf) = 125.66 $\text{Pi} * (\text{D}_R/24)^2 * \text{Total Ht of Riser}$
 Convert cf to cy = 27^{-1}
 Min Concrete Needed (cy) = 3.32
 Width & Length (ft) = 6
 Thickness (ft) = 2.5

Anti-Vortex Device:

Diameter of Riser (in) = 60 From Hydrograph
 Cylinder Diameter (in) = 90 Ref 3, III-104, Table 3.14-D
 Cylinder Thickness (gage) = 14
 Cylinder Height (in) = 29

Determine Tailwater conditions to size outlet apron

Use Normal Depth Procedure (Manning's Eqn.) Ref 2, II-7

$A * R^{2/3} = Q * n / 1.49 s^{0.5}$ Area (A) = $bd + z(d^2)$ $Z_{av} = A * R^{2/3}$
 $Z_{req} = Q * n / 1.49 s^{0.5}$ $R = \text{Area} / (b + 2d((z^2 + 1)^{0.5}))$

n = 0.069 6-inch diameter Rip Rap, Lined Channel
 Vp (ft/sec) = 9 Permissible Velocity for lining
 Side Slope (z) = 5 enter X for X:1
 s (ft/ft) = 0.02 Outlet Slope (estimated)
 Bottom Width (ft) = 12 6 * Barrel Diameter
 Q_B (cfs) = 34.3 Peak Flow out of the barrel 25-yr Hydrograph

Q (cfs)	Z _{req}	Flow Depth d (ft)	A (sf)	R (ft)	Z _{av}	V (ft/sec)
34.3	11.23	0.88	14.4	0.69	11.23	2.4

Flow Depth = Tailwater, d (ft) = 0.88 0.5* Barrel Diameter (ft) = 1.00 Ref 1, 8.06.3
 Minimum Tailwater Conditions: $d < 0.5 * \text{Diameter of Outlet Pipe}$
 Maximum Tailwater Conditions: $d > 0.5 * \text{Diameter of Outlet Pipe}$

Since the Tailwater is less than half of the diameter of the outlet, use Minimum Tailwater conditions.

Barrel Diameter (ft)	Entrance (ft)	Length (ft)	Outlet Width (ft)	Median Rip Rap Size d ₅₀	Selected Rip Rap Size (in)
2	6	10	12	0.7	Class B

Conclusion

The basin can contain the 10-yr storm and pass the 100-yr storm without overtopping the berm.

HDR Computation

Project:	Charah Colon Mine	Computed: PAW	Date: 12/31/14
Subject:	Permit Application	Checked: EAW	Date: 1/2/15
Task:	Riser Pipe Perforations/Skimmer Flow	Sheet 1	Of 2

Diameter of Riser (in) = 60
 Circumference of Riser (in) = 188.5
 Height of Riser from bottom of barrel (in) = 77 From Hydrograph
 Vertical spacing between holes (in) = 0 center to center
 Water Stage increment (ft) 0.05

Orifice Equation

$Q = C_d * A * (2 * g * h)^{0.5}$ Ref 1, p III-11
 Q = cfs, discharge
 $C_d = 0.6$ coefficient of discharge
 A = sf, cross sectional area
 $g = 32.2$ ft/sec², gravity
 h = ft, driving head measured from the center of the pipe

Row	Perforations					Skimmer	# of skimmers
	1	2	3	4	5	2	
Holes per row	0	0	0	0	0		
Hole Diameter (in)	0.75	0.75	0.75	0.75	0.75		
Spacing edge to edge (in)							
Inlet Area (sf)	0.000	0.000	0.000	0.000	0.000		
Hole Stage (in)	0.50	0.50	0.50	0.50	0.50		
Hole Stage (ft)	0.04	0.04	0.04	0.04	0.04		

Water Stage (ft)	Flow (cfs)	Flow (cfs)	Flow (cfs)	Flow (cfs)	Flow (cfs)	Flow (cfs)	Total Flow (cfs)
0.00	0.00	0.00	0.00			0.00	0.00
0.04	0.00	0.00	0.00			0.00	0.00
0.09	0.00	0.00	0.00			0.00	0.00
0.14	0.00	0.00	0.00			0.00	0.00
0.19	0.00	0.00	0.00			0.00	0.00
0.24	0.00	0.00	0.00			0.00	0.00
0.29	0.00	0.00	0.00			0.00	0.00
0.34	0.00	0.00	0.00			0.38	0.38
0.39	0.00	0.00	0.00			0.38	0.38
0.44	0.00	0.00	0.00			0.38	0.38
0.49	0.00	0.00	0.00			0.38	0.38
0.54	0.00	0.00	0.00			0.38	0.38
0.59	0.00	0.00	0.00			0.38	0.38
0.64	0.00	0.00	0.00			0.38	0.38
0.69	0.00	0.00	0.00			0.38	0.38
0.74	0.00	0.00	0.00			0.38	0.38
0.79	0.00	0.00	0.00			0.38	0.38
0.84	0.00	0.00	0.00			0.38	0.38
0.89	0.00	0.00	0.00			0.38	0.38
0.94	0.00	0.00	0.00			0.38	0.38
0.99	0.00	0.00	0.00			0.38	0.38
1.04	0.00	0.00	0.00			0.38	0.38
1.09	0.00	0.00	0.00			0.38	0.38
1.14	0.00	0.00	0.00			0.38	0.38
1.19	0.00	0.00	0.00			0.38	0.38
1.24	0.00	0.00	0.00			0.38	0.38
1.29	0.00	0.00	0.00			0.38	0.38
1.34	0.00	0.00	0.00			0.38	0.38
1.39	0.00	0.00	0.00			0.38	0.38
1.44	0.00	0.00	0.00			0.38	0.38
1.49	0.00	0.00	0.00			0.38	0.38
1.54	0.00	0.00	0.00			0.38	0.38
1.59	0.00	0.00	0.00			0.38	0.38

HDR Computation

Project:	Charah Colon Mine	Computed: PAW	Date: 12/31/14
Subject:	Permit Application	Checked: EAW	Date: 1/2/15
Task:	Riser Pipe Perforations/Skimmer Flow	Sheet 2	Of 2

1.64	0.00	0.00	0.00	0.38	0.38
1.69	0.00	0.00	0.00	0.38	0.38
1.74	0.00	0.00	0.00	0.38	0.38
1.79	0.00	0.00	0.00	0.38	0.38
1.84	0.00	0.00	0.00	0.38	0.38
1.89	0.00	0.00	0.00	0.38	0.38
1.94	0.00	0.00	0.00	0.38	0.38
1.99	0.00	0.00	0.00	0.38	0.38
2.04	0.00	0.00	0.00	0.38	0.38
2.09	0.00	0.00	0.00	0.38	0.38
2.14	0.00	0.00	0.00	0.38	0.38
2.19	0.00	0.00	0.00	0.38	0.38
2.24	0.00	0.00	0.00	0.38	0.38
2.29	0.00	0.00	0.00	0.38	0.38
2.34	0.00	0.00	0.00	0.38	0.38
2.39	0.00	0.00	0.00	0.38	0.38
2.44	0.00	0.00	0.00	0.38	0.38
2.49	0.00	0.00	0.00	0.38	0.38
2.54	0.00	0.00	0.00	0.38	0.38
2.59	0.00	0.00	0.00	0.38	0.38
2.64	0.00	0.00	0.00	0.38	0.38
2.69	0.00	0.00	0.00	0.38	0.38
2.74	0.00	0.00	0.00	0.38	0.38
2.79	0.00	0.00	0.00	0.38	0.38
2.84	0.00	0.00	0.00	0.38	0.38
2.89	0.00	0.00	0.00	0.38	0.38
2.94	0.00	0.00	0.00	0.38	0.38
2.99	0.00	0.00	0.00	0.38	0.38
3.04	0.00	0.00	0.00	0.38	0.38
3.09	0.00	0.00	0.00	0.38	0.38
3.14	0.00	0.00	0.00	0.38	0.38
3.19	0.00	0.00	0.00	0.38	0.38
3.24	0.00	0.00	0.00	0.38	0.38
3.29	0.00	0.00	0.00	0.38	0.38
3.34	0.00	0.00	0.00	0.38	0.38
3.39	0.00	0.00	0.00	0.38	0.38
3.44	0.00	0.00	0.00	0.38	0.38
3.49	0.00	0.00	0.00	0.38	0.38
3.54	0.00	0.00	0.00	0.38	0.38
3.59	0.00	0.00	0.00	0.38	0.38
3.64	0.00	0.00	0.00	0.38	0.38
3.69	0.00	0.00	0.00	0.38	0.38
3.74	0.00	0.00	0.00	0.38	0.38
3.79	0.00	0.00	0.00	0.38	0.38
3.84	0.00	0.00	0.00	0.38	0.38
3.89	0.00	0.00	0.00	0.38	0.38
3.94	0.00	0.00	0.00	0.38	0.38
3.99	0.00	0.00	0.00	0.38	0.38

Sediment Basin # 7 Colon

Qp = 85.59 cfs
 Tp = 27.78 minutes
 dT = Max of 2 minutes
 or 1.0% of increment to peak

Phase 1
 10 - year Storm Event

b = 1.1
 K_s = 46,662

Number of Riser/Barrel Assemblies = 2
 Diameter of Barrel = 24 (in)
 Height of Riser above barrel = 4.4 (ft)
 Height of Riser from bottom of barrel = 6.4 (ft) elevation 244.40
 Emergency Spillway = 6.9 (ft) elevation 244.90
 Total Height of Dam = 7.5 (ft) elevation 245.50
 Length of Emergency Spillway = 20 (ft)
 Diameter of Riser = 60 (in)
 Permanent Pond Stage = 0 (ft) elevation 238.0

4.0E-03 Settling Velocity of design particle (fps)
 2 Effective number of cells (2 is construction site #)
 100% Minimum Settling Efficiency
 3.5 ft Maximum Stage 241.48 msl elevation
 0.8 cfs Peak outflow
 0.8 cfs Peak Riser/Barrel outflow
 0.0 cfs Peak Weir flow

Notes:

1. Length of emergency spillway is the bottom width of the emergency spillway.
2. Settling efficiency neglects permanent pond volume

TIME (min)	INFLOW [cfs]	STORAGE [cu ft]	STAGE [ft]	Skimmer Flow [cfs]	RISER CAPACIT Y [cfs]	WEIR FLOW [cfs]	BARREL CAPACITY [cfs]	TOTAL OUTFLOW [cfs]	Bound Discharge [cfs]	Estimated Surface Area (sf)	Settling Efficiency [%]
0	0.0	0	0.0	0.00	0.00	0.00	0.00	0.00	0.00	-	N/A
2	1.1	0	0.0	0.00	0.00	0.00	0.00	0.00	0.00	-	N/A
4	4.3	131	0.0	0.00	0.00	0.00	0.00	0.00	57.19	25,995	N/A
6	9.5	647	0.0	0.00	0.00	0.00	0.00	0.00	69.47	31,575	N/A
8	16.4	1,785	0.1	0.00	0.00	0.00	0.00	0.00	78.58	35,720	N/A
10	24.6	3,748	0.1	0.00	0.00	0.00	0.00	0.00	86.00	39,091	N/A
12	33.7	6,696	0.2	0.00	0.00	0.00	0.00	0.00	92.29	41,951	N/A
14	43.3	10,743	0.3	0.00	0.00	0.00	0.00	0.00	97.75	44,433	N/A
16	52.9	15,943	0.4	0.38	0.38	0.00	0.38	0.75	102.56	46,618	100%
18	62.0	22,203	0.5	0.38	0.38	0.00	0.38	0.75	106.77	48,534	100%
20	70.1	29,550	0.7	0.38	0.38	0.00	0.38	0.75	110.55	50,251	100%
22	76.8	37,868	0.8	0.38	0.38	0.00	0.38	0.75	113.94	51,790	100%
24	81.7	46,991	1.0	0.38	0.38	0.00	0.38	0.75	116.97	53,167	100%
26	84.7	56,709	1.2	0.38	0.38	0.00	0.38	0.75	119.67	54,397	100%
28	85.6	66,786	1.4	0.38	0.38	0.00	0.38	0.75	122.08	55,490	100%
30	84.2	76,965	1.6	0.38	0.38	0.00	0.38	0.75	124.20	56,455	100%
32	80.8	86,984	1.7	0.38	0.38	0.00	0.38	0.75	126.06	57,302	100%
34	75.4	96,589	1.9	0.38	0.38	0.00	0.38	0.75	127.68	58,036	100%
36	68.9	105,550	2.0	0.38	0.38	0.00	0.38	0.75	129.06	58,666	100%
38	62.7	113,727	2.2	0.38	0.38	0.00	0.38	0.75	130.24	59,201	100%
40	57.1	121,166	2.3	0.38	0.38	0.00	0.38	0.75	131.25	59,658	100%
42	52.0	127,931	2.4	0.38	0.38	0.00	0.38	0.75	132.12	60,054	100%
44	47.4	134,084	2.5	0.38	0.38	0.00	0.38	0.75	132.88	60,398	100%
46	43.1	139,680	2.6	0.38	0.38	0.00	0.38	0.75	133.54	60,699	100%
48	39.3	144,767	2.7	0.38	0.38	0.00	0.38	0.75	134.12	60,964	100%
50	35.8	149,391	2.8	0.38	0.38	0.00	0.38	0.75	134.63	61,197	100%
52	32.6	153,595	2.8	0.38	0.38	0.00	0.38	0.75	135.09	61,404	100%
54	29.7	157,414	2.9	0.38	0.38	0.00	0.38	0.75	135.49	61,588	100%
56	27.0	160,884	3.0	0.38	0.38	0.00	0.38	0.75	135.85	61,751	100%
58	24.6	164,036	3.0	0.38	0.38	0.00	0.38	0.75	136.17	61,897	100%
60	22.4	166,899	3.1	0.38	0.38	0.00	0.38	0.75	136.46	62,028	100%
62	20.4	169,497	3.1	0.38	0.38	0.00	0.38	0.75	136.72	62,144	100%
64	18.6	171,855	3.1	0.38	0.38	0.00	0.38	0.75	136.95	62,249	100%
66	16.9	173,995	3.2	0.38	0.38	0.00	0.38	0.75	137.15	62,342	100%
68	15.4	175,935	3.2	0.38	0.38	0.00	0.38	0.75	137.34	62,427	100%
70	14.0	177,693	3.2	0.38	0.38	0.00	0.38	0.75	137.50	62,502	100%
72	12.8	179,287	3.3	0.38	0.38	0.00	0.38	0.75	137.65	62,570	100%
74	11.6	180,730	3.3	0.38	0.38	0.00	0.38	0.75	137.79	62,631	100%
76	10.6	182,036	3.3	0.38	0.38	0.00	0.38	0.75	137.91	62,686	100%
78	9.7	183,217	3.3	0.38	0.38	0.00	0.38	0.75	138.02	62,735	100%
80	8.8	184,285	3.3	0.38	0.38	0.00	0.38	0.75	138.12	62,780	100%
82	8.0	185,249	3.4	0.38	0.38	0.00	0.38	0.75	138.20	62,819	100%

84	7.3	186,118	3.4	0.38	0.38	0.00	0.38	0.75	138.28	62,855	100%
86	6.6	186,902	3.4	0.38	0.38	0.00	0.38	0.75	138.35	62,887	100%
88	6.0	187,608	3.4	0.38	0.38	0.00	0.38	0.75	138.42	62,916	100%
90	5.5	188,243	3.4	0.38	0.38	0.00	0.38	0.75	138.47	62,942	100%
92	5.0	188,813	3.4	0.38	0.38	0.00	0.38	0.75	138.52	62,965	100%
94	4.6	189,324	3.4	0.38	0.38	0.00	0.38	0.75	138.57	62,986	100%
96	4.2	189,781	3.4	0.38	0.38	0.00	0.38	0.75	138.61	63,004	100%
98	3.8	190,189	3.4	0.38	0.38	0.00	0.38	0.75	138.65	63,021	100%
100	3.4	190,553	3.4	0.38	0.38	0.00	0.38	0.75	138.68	63,035	100%
102	3.1	190,876	3.4	0.38	0.38	0.00	0.38	0.75	138.71	63,048	100%
104	2.9	191,162	3.5	0.38	0.38	0.00	0.38	0.75	138.73	63,060	100%
106	2.6	191,414	3.5	0.38	0.38	0.00	0.38	0.75	138.75	63,070	100%
108	2.4	191,636	3.5	0.38	0.38	0.00	0.38	0.75	138.77	63,079	100%
110	2.2	191,830	3.5	0.38	0.38	0.00	0.38	0.75	138.79	63,087	100%
112	2.0	191,999	3.5	0.38	0.38	0.00	0.38	0.75	138.81	63,093	100%
114	1.8	192,144	3.5	0.38	0.38	0.00	0.38	0.75	138.82	63,099	100%
116	1.6	192,268	3.5	0.38	0.38	0.00	0.38	0.75	138.83	63,104	100%
118	1.5	192,373	3.5	0.38	0.38	0.00	0.38	0.75	138.84	63,108	100%
120	1.4	192,461	3.5	0.38	0.38	0.00	0.38	0.75	138.85	63,112	100%
122	1.2	192,532	3.5	0.38	0.38	0.00	0.38	0.75	138.85	63,115	100%
124	1.1	192,590	3.5	0.38	0.38	0.00	0.38	0.75	138.86	63,117	100%
126	1.0	192,634	3.5	0.38	0.38	0.00	0.38	0.75	138.86	63,119	100%
128	0.9	192,666	3.5	0.38	0.38	0.00	0.38	0.75	138.86	63,120	100%
130	0.8	192,687	3.5	0.38	0.38	0.00	0.38	0.75	138.87	63,121	100%
132	0.8	192,698	3.5	0.38	0.38	0.00	0.38	0.75	138.87	63,121	100%
134	0.7	192,700	3.5	0.38	0.38	0.00	0.38	0.75	138.87	63,121	100%
136	0.6	192,693	3.5	0.38	0.38	0.00	0.38	0.75	138.87	63,121	100%
138	0.6	192,679	3.5	0.38	0.38	0.00	0.38	0.75	138.87	63,121	100%
140	0.5	192,659	3.5	0.38	0.38	0.00	0.38	0.75	138.86	63,120	100%
142	0.5	192,632	3.5	0.38	0.38	0.00	0.38	0.75	138.86	63,119	100%
144	0.4	192,599	3.5	0.38	0.38	0.00	0.38	0.75	138.86	63,117	100%
146	0.4	192,561	3.5	0.38	0.38	0.00	0.38	0.75	138.86	63,116	100%
148	0.4	192,519	3.5	0.38	0.38	0.00	0.38	0.75	138.85	63,114	100%
150	0.3	192,472	3.5	0.38	0.38	0.00	0.38	0.75	138.85	63,112	100%
152	0.3	192,421	3.5	0.38	0.38	0.00	0.38	0.75	138.84	63,110	100%
154	0.3	192,367	3.5	0.38	0.38	0.00	0.38	0.75	138.84	63,108	100%
156	0.3	192,310	3.5	0.38	0.38	0.00	0.38	0.75	138.83	63,106	100%
158	0.2	192,249	3.5	0.38	0.38	0.00	0.38	0.75	138.83	63,103	100%
160	0.2	192,186	3.5	0.38	0.38	0.00	0.38	0.75	138.82	63,101	100%
162	0.2	192,120	3.5	0.38	0.38	0.00	0.38	0.75	138.82	63,098	100%
164	0.2	192,053	3.5	0.38	0.38	0.00	0.38	0.75	138.81	63,096	100%
166	0.2	191,983	3.5	0.38	0.38	0.00	0.38	0.75	138.80	63,093	100%
168	0.1	191,911	3.5	0.38	0.38	0.00	0.38	0.75	138.80	63,090	100%
170	0.1	191,838	3.5	0.38	0.38	0.00	0.38	0.75	138.79	63,087	100%
172	0.1	191,763	3.5	0.38	0.38	0.00	0.38	0.75	138.78	63,084	100%
174	0.1	191,686	3.5	0.38	0.38	0.00	0.38	0.75	138.78	63,081	100%
176	0.1	191,609	3.5	0.38	0.38	0.00	0.38	0.75	138.77	63,078	100%
178	0.1	191,530	3.5	0.38	0.38	0.00	0.38	0.75	138.76	63,075	100%
180	0.1	191,450	3.5	0.38	0.38	0.00	0.38	0.75	138.76	63,072	100%
182	0.1	191,370	3.5	0.38	0.38	0.00	0.38	0.75	138.75	63,068	100%
184	0.1	191,288	3.5	0.38	0.38	0.00	0.38	0.75	138.74	63,065	100%
186	0.1	191,205	3.5	0.38	0.38	0.00	0.38	0.75	138.74	63,062	100%
188	0.1	191,122	3.5	0.38	0.38	0.00	0.38	0.75	138.73	63,058	100%
190	0.1	191,039	3.4	0.38	0.38	0.00	0.38	0.75	138.72	63,055	100%
192	0.0	190,954	3.4	0.38	0.38	0.00	0.38	0.75	138.71	63,052	100%
194	0.0	190,869	3.4	0.38	0.38	0.00	0.38	0.75	138.71	63,048	100%
196	0.0	190,784	3.4	0.38	0.38	0.00	0.38	0.75	138.70	63,045	100%
198	0.0	190,698	3.4	0.38	0.38	0.00	0.38	0.75	138.69	63,041	100%
200	0.0	190,611	3.4	0.38	0.38	0.00	0.38	0.75	138.68	63,038	100%
202	0.0	190,525	3.4	0.38	0.38	0.00	0.38	0.75	138.68	63,034	100%
204	0.0	190,438	3.4	0.38	0.38	0.00	0.38	0.75	138.67	63,031	100%
206	0.0	190,350	3.4	0.38	0.38	0.00	0.38	0.75	138.66	63,027	100%

**Sediment Basin #7 Colon Mine Phase 1 Hydrograph
10-Yr Storm**

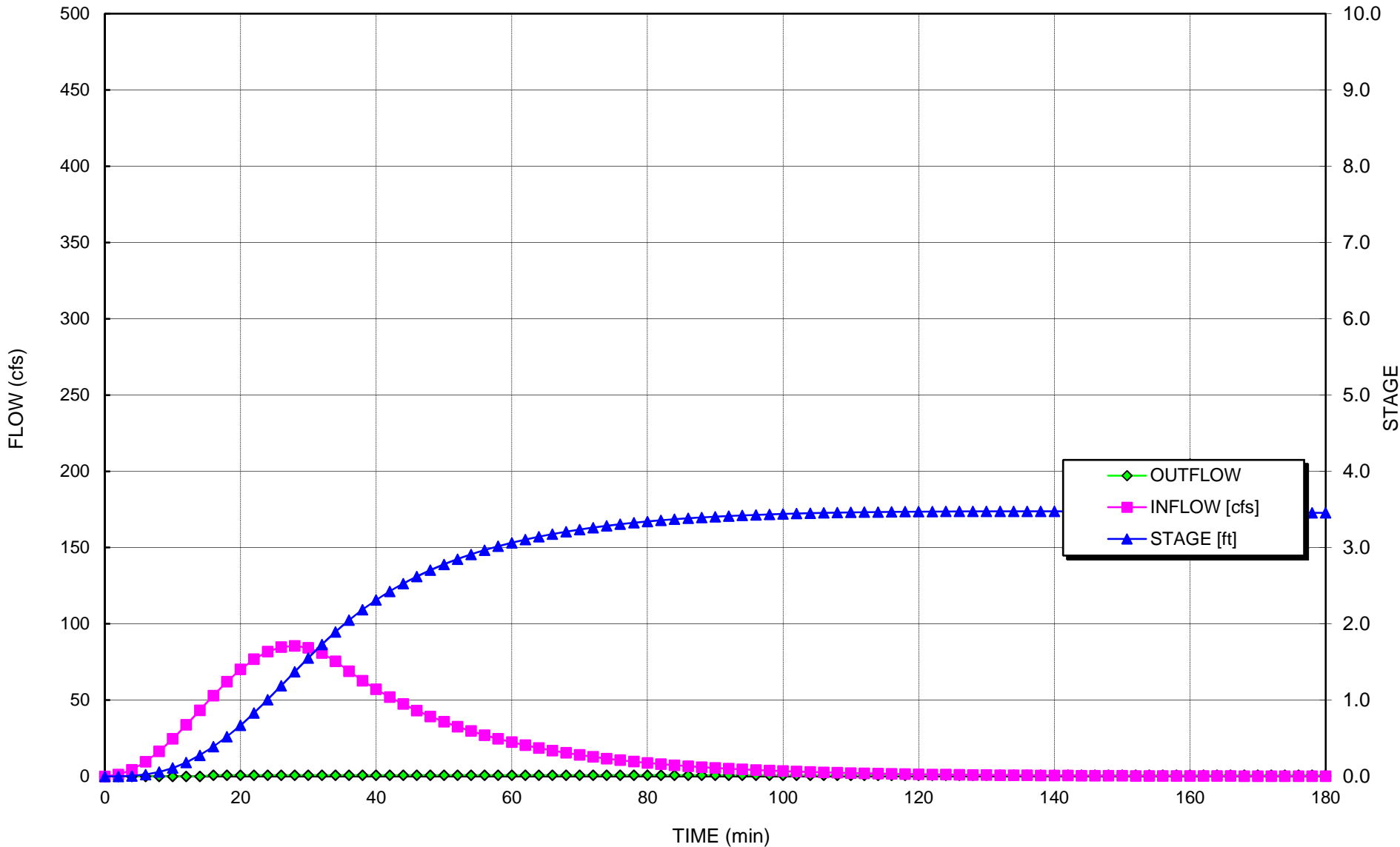

Qp = 134.71 cfs
 Tp = 34.59 minutes
 dT = Max of 2 minutes
 or 1.0% of increment to peak

Sediment Basin # 7 **Colon**
 Phase 2
10 - year Storm Event

Number of Riser/Barrel Assemblies = 2
 Diameter of Barrel = 24 (in)
 Height of Riser above barrel = 4.4 (ft)
 Height of Riser from bottom of barrel = 6.4 (ft) elevation 244.40
 Emergency Spillway = 6.9 (ft) elevation 244.90
 Total Height of Dam = 7.5 (ft) elevation 245.50
 Length of Emergency Spillway = 20 (ft)
 Diameter of Riser = 60 (in)
 Permanent Pond Stage = 0 (ft) elevation 238.0

b = 1.1
 Ks = 46,662

4.0E-03 Settling Velocity of design particle (fps)
 2 Effective number of cells (2 is construction site #)

100% Minimum Settling Efficiency	
6.3 ft Maximum Stage	244.33 msl elevation
0.8 cfs Peak outflow	
0.8 cfs Peak Riser/Barrel outflow	
0.0 cfs peak weir flow	

Notes:

1. Length of emergency spillway is the bottom width of the emergency spillway.
2. Settling efficiency neglects permanent pond volume

TIME (min)	INFLOW [cfs]	STORAGE [cu ft]	STAGE [ft]	Skimmer Flow [cfs]	RISER CAPACIT Y [cfs]	WEIR FLOW [cfs]	BARREL CAPACIT Y [cfs]	TOTAL OUTFLOW [cfs]	Bound Discharge [cfs]	Estimated Surface Area (sf)	Settling Efficiency [%]
0	0.0	0	0.0	0.00	0.00	0.00	0.00	0.00	0.00	-	N/A
2	1.1	0	0.0	0.00	0.00	0.00	0.00	0.00	0.00	-	N/A
4	4.4	133	0.0	0.00	0.00	0.00	0.00	0.00	57.30	26,047	N/A
6	9.8	661	0.0	0.00	0.00	0.00	0.00	0.00	69.64	31,653	N/A
8	17.0	1,832	0.1	0.00	0.00	0.00	0.00	0.00	78.83	35,832	N/A
10	25.9	3,873	0.1	0.00	0.00	0.00	0.00	0.00	86.35	39,249	N/A
12	36.2	6,984	0.2	0.00	0.00	0.00	0.00	0.00	92.77	42,166	N/A
14	47.5	11,329	0.3	0.00	0.00	0.00	0.00	0.00	98.39	44,721	N/A
16	59.5	17,029	0.4	0.38	0.38	0.00	0.38	0.75	103.39	46,993	100%
18	71.7	24,074	0.6	0.38	0.38	0.00	0.38	0.75	107.83	49,014	100%
20	83.7	32,584	0.7	0.38	0.38	0.00	0.38	0.75	111.87	50,852	100%
22	95.3	42,544	0.9	0.38	0.38	0.00	0.38	0.75	115.56	52,528	100%
24	105.9	53,887	1.1	0.38	0.38	0.00	0.38	0.75	118.93	54,060	100%
26	115.2	66,504	1.4	0.38	0.38	0.00	0.38	0.75	122.01	55,461	100%
28	123.0	80,242	1.6	0.38	0.38	0.00	0.38	0.75	124.83	56,742	100%
30	128.9	94,912	1.9	0.38	0.38	0.00	0.38	0.75	127.41	57,913	100%
32	132.9	110,296	2.1	0.38	0.38	0.00	0.38	0.75	129.76	58,980	100%
34	134.6	126,148	2.4	0.38	0.38	0.00	0.38	0.75	131.89	59,952	100%
36	134.2	142,211	2.7	0.38	0.38	0.00	0.38	0.75	133.83	60,832	100%
38	131.5	158,220	2.9	0.38	0.38	0.00	0.38	0.75	135.58	61,626	100%
40	126.7	173,909	3.2	0.38	0.38	0.00	0.38	0.75	137.15	62,339	100%
42	120.0	189,026	3.4	0.38	0.38	0.00	0.38	0.75	138.54	62,974	100%
44	111.9	203,337	3.6	0.38	0.38	0.00	0.38	0.75	139.78	63,535	100%
46	103.8	216,669	3.9	0.38	0.38	0.00	0.38	0.75	140.86	64,028	100%
48	96.2	229,028	4.0	0.38	0.38	0.00	0.38	0.75	141.81	64,461	100%
50	89.3	240,487	4.2	0.38	0.38	0.00	0.38	0.75	142.66	64,845	100%
52	82.8	251,109	4.4	0.38	0.38	0.00	0.38	0.75	143.41	65,187	100%
54	76.8	260,955	4.5	0.38	0.38	0.00	0.38	0.75	144.08	65,492	100%
56	71.2	270,081	4.7	0.38	0.38	0.00	0.38	0.75	144.69	65,767	100%
58	66.1	278,541	4.8	0.38	0.38	0.00	0.38	0.75	145.23	66,014	100%
60	61.3	286,381	4.9	0.38	0.38	0.00	0.38	0.75	145.72	66,237	100%
62	56.9	293,646	5.0	0.38	0.38	0.00	0.38	0.75	146.17	66,439	100%
64	52.7	300,379	5.1	0.38	0.38	0.00	0.38	0.75	146.57	66,623	100%
66	48.9	306,618	5.2	0.38	0.38	0.00	0.38	0.75	146.94	66,789	100%
68	45.4	312,399	5.3	0.38	0.38	0.00	0.38	0.75	147.27	66,941	100%
70	42.1	317,754	5.4	0.38	0.38	0.00	0.38	0.75	147.58	67,080	100%
72	39.0	322,715	5.5	0.38	0.38	0.00	0.38	0.75	147.85	67,206	100%
74	36.2	327,310	5.5	0.38	0.38	0.00	0.38	0.75	148.11	67,322	100%
76	33.6	331,566	5.6	0.38	0.38	0.00	0.38	0.75	148.34	67,428	100%
78	31.2	335,507	5.7	0.38	0.38	0.00	0.38	0.75	148.55	67,525	100%
80	28.9	339,156	5.7	0.38	0.38	0.00	0.38	0.75	148.75	67,614	100%
82	26.8	342,534	5.8	0.38	0.38	0.00	0.38	0.75	148.93	67,695	100%
84	24.9	345,661	5.8	0.38	0.38	0.00	0.38	0.75	149.09	67,770	100%

86	23.1	348,555	5.8	0.38	0.38	0.00	0.38	0.75	149.25	67,839	100%
88	21.4	351,233	5.9	0.38	0.38	0.00	0.38	0.75	149.38	67,902	100%
90	19.9	353,711	5.9	0.38	0.38	0.00	0.38	0.75	149.51	67,960	100%
92	18.4	356,002	6.0	0.38	0.38	0.00	0.38	0.75	149.63	68,014	100%
94	17.1	358,121	6.0	0.38	0.38	0.00	0.38	0.75	149.74	68,063	100%
96	15.8	360,080	6.0	0.38	0.38	0.00	0.38	0.75	149.84	68,108	100%
98	14.7	361,891	6.0	0.38	0.38	0.00	0.38	0.75	149.93	68,149	100%
100	13.6	363,563	6.1	0.38	0.38	0.00	0.38	0.75	150.01	68,188	100%
102	12.6	365,109	6.1	0.38	0.38	0.00	0.38	0.75	150.09	68,223	100%
104	11.7	366,535	6.1	0.38	0.38	0.00	0.38	0.75	150.16	68,255	100%
106	10.9	367,852	6.1	0.38	0.38	0.00	0.38	0.75	150.23	68,285	100%
108	10.1	369,067	6.2	0.38	0.38	0.00	0.38	0.75	150.29	68,312	100%
110	9.4	370,188	6.2	0.38	0.38	0.00	0.38	0.75	150.34	68,337	100%
112	8.7	371,220	6.2	0.38	0.38	0.00	0.38	0.75	150.39	68,361	100%
114	8.1	372,172	6.2	0.38	0.38	0.00	0.38	0.75	150.44	68,382	100%
116	7.5	373,048	6.2	0.38	0.38	0.00	0.38	0.75	150.48	68,401	100%
118	6.9	373,853	6.2	0.38	0.38	0.00	0.38	0.75	150.52	68,419	100%
120	6.4	374,594	6.2	0.38	0.38	0.00	0.38	0.75	150.56	68,436	100%
122	6.0	375,275	6.2	0.38	0.38	0.00	0.38	0.75	150.59	68,451	100%
124	5.5	375,900	6.3	0.38	0.38	0.00	0.38	0.75	150.62	68,465	100%
126	5.1	376,473	6.3	0.38	0.38	0.00	0.38	0.75	150.65	68,478	100%
128	4.8	376,998	6.3	0.38	0.38	0.00	0.38	0.75	150.68	68,489	100%
130	4.4	377,479	6.3	0.38	0.38	0.00	0.38	0.75	150.70	68,500	100%
132	4.1	377,918	6.3	0.38	0.38	0.00	0.38	0.75	150.72	68,509	100%
134	3.8	378,319	6.3	0.38	0.38	0.00	0.38	0.75	150.74	68,518	100%
136	3.5	378,684	6.3	0.38	0.38	0.00	0.38	0.75	150.76	68,526	100%
138	3.3	379,016	6.3	0.38	0.38	0.00	0.38	0.75	150.77	68,534	100%
140	3.0	379,318	6.3	0.38	0.38	0.00	0.38	0.75	150.79	68,540	100%
142	2.8	379,591	6.3	0.38	0.38	0.00	0.38	0.75	150.80	68,546	100%
144	2.6	379,838	6.3	0.38	0.38	0.00	0.38	0.75	150.81	68,552	100%
146	2.4	380,060	6.3	0.38	0.38	0.00	0.38	0.75	150.82	68,557	100%
148	2.2	380,260	6.3	0.38	0.38	0.00	0.38	0.75	150.83	68,561	100%
150	2.1	380,438	6.3	0.38	0.38	0.00	0.38	0.75	150.84	68,565	100%
152	1.9	380,598	6.3	0.38	0.38	0.00	0.38	0.75	150.85	68,568	100%
154	1.8	380,739	6.3	0.38	0.38	0.00	0.38	0.75	150.86	68,571	100%
156	1.7	380,863	6.3	0.38	0.38	0.00	0.38	0.75	150.86	68,574	100%
158	1.5	380,972	6.3	0.38	0.38	0.00	0.38	0.75	150.87	68,577	100%
160	1.4	381,066	6.3	0.38	0.38	0.00	0.38	0.75	150.87	68,579	100%
162	1.3	381,147	6.3	0.38	0.38	0.00	0.38	0.75	150.88	68,580	100%
164	1.2	381,216	6.3	0.38	0.38	0.00	0.38	0.75	150.88	68,582	100%
166	1.1	381,273	6.3	0.38	0.38	0.00	0.38	0.75	150.88	68,583	100%
168	1.1	381,319	6.3	0.38	0.38	0.00	0.38	0.75	150.89	68,584	100%
170	1.0	381,356	6.3	0.38	0.38	0.00	0.38	0.75	150.89	68,585	100%
172	0.9	381,383	6.3	0.38	0.38	0.00	0.38	0.75	150.89	68,586	100%
174	0.8	381,402	6.3	0.38	0.38	0.00	0.38	0.75	150.89	68,586	100%
176	0.8	381,412	6.3	0.38	0.38	0.00	0.38	0.75	150.89	68,586	100%
178	0.7	381,416	6.3	0.38	0.38	0.00	0.38	0.75	150.89	68,586	100%
180	0.7	381,412	6.3	0.38	0.38	0.00	0.38	0.75	150.89	68,586	100%
182	0.6	381,403	6.3	0.38	0.38	0.00	0.38	0.75	150.89	68,586	100%
184	0.6	381,387	6.3	0.38	0.38	0.00	0.38	0.75	150.89	68,586	100%
186	0.5	381,366	6.3	0.38	0.38	0.00	0.38	0.75	150.89	68,585	100%
188	0.5	381,340	6.3	0.38	0.38	0.00	0.38	0.75	150.89	68,585	100%
190	0.5	381,310	6.3	0.38	0.38	0.00	0.38	0.75	150.88	68,584	100%
192	0.4	381,275	6.3	0.38	0.38	0.00	0.38	0.75	150.88	68,583	100%
194	0.4	381,236	6.3	0.38	0.38	0.00	0.38	0.75	150.88	68,582	100%
196	0.4	381,193	6.3	0.38	0.38	0.00	0.38	0.75	150.88	68,581	100%
198	0.3	381,147	6.3	0.38	0.38	0.00	0.38	0.75	150.88	68,580	100%
200	0.3	381,097	6.3	0.38	0.38	0.00	0.38	0.75	150.87	68,579	100%
202	0.3	381,045	6.3	0.38	0.38	0.00	0.38	0.75	150.87	68,578	100%
204	0.3	380,990	6.3	0.38	0.38	0.00	0.38	0.75	150.87	68,577	100%

Sediment Basin #7 Colon Mine Phase 2 Hydrograph 10-Yr Storm

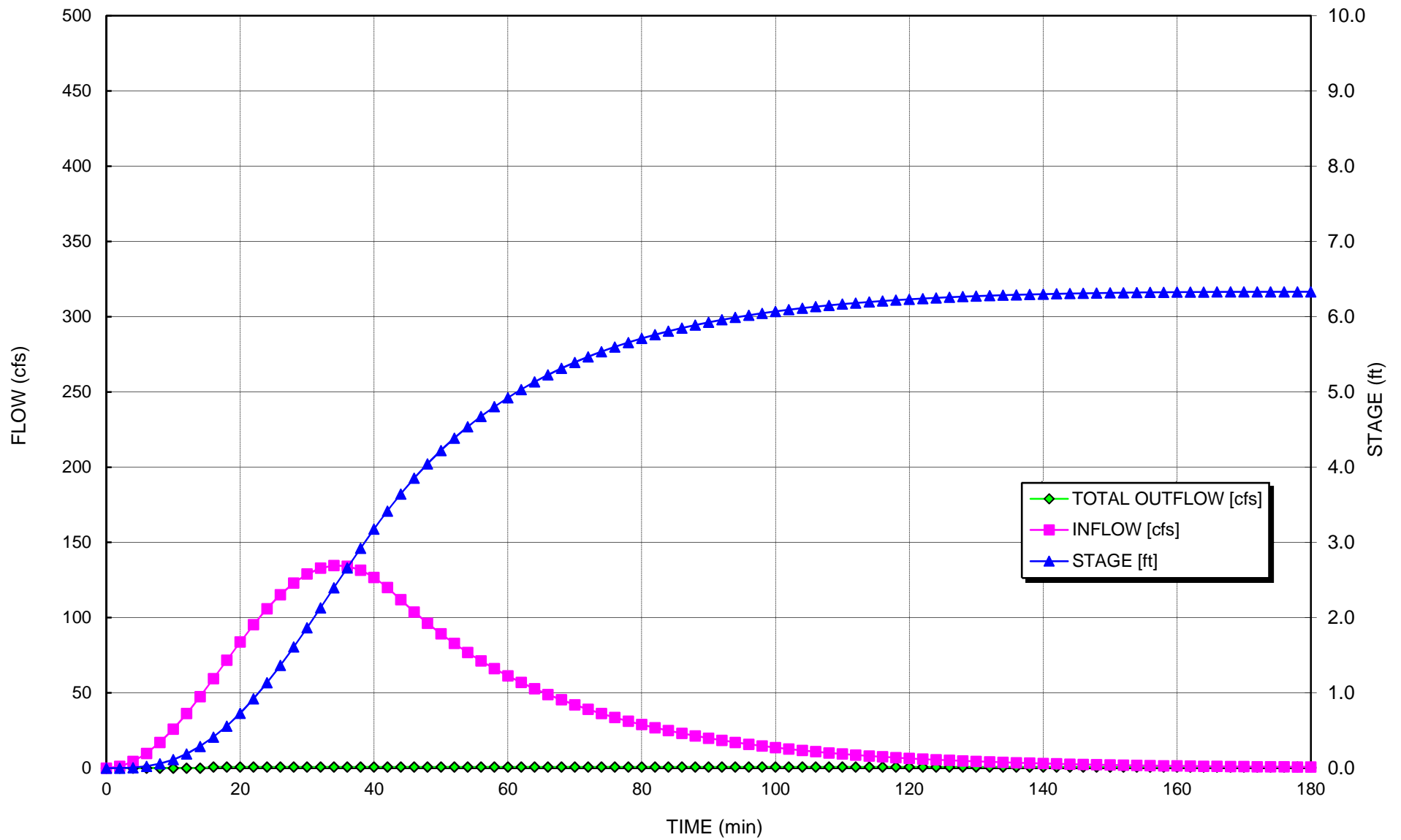

Qp = 171.36 cfs
 Tp = 34.80 minutes
 dT = Max of 2 minutes
 or 1.0% of increment to peak

Sediment Basin # 7 Colon
 Phase 2
25 - year Storm Event

Number of Riser/Barrel Assemblies = 2
 Diameter of Barrel = 24 (in)
 Height of Riser above barrel = 4.4 (ft)
 Height of Riser from bottom of barrel = 6.4 (ft) elevatior 244.40
 Emergency Spillway = 6.9 (ft) elevatior 244.90
 Total Height of Dam = 7.5 (ft) elevatior 245.50
 Length of Emergency Spillway = 20 (ft)
 Diameter of Riser = 60 (in)
 Permanent Pond Stage = 0 (ft) elevatior 238.0

b = 1.1
 Ks = 46,662

4.0E-03 Settling Velocity of design particle (fps)
 2 Effective number of cells (2 is construction site #)

96% Minimum Settling Efficiency	
6.9 ft Maximum Stage	244.9 msl elevation
34.3 cfs Peak outflow	
34.3 cfs Peak Riser/Barrel outflow	
0.0 cfs peak weir flow	

Notes:

1. Length of emergency spillway is the bottom width of the emergency spillway.
2. Settling efficiency neglects permanent pond volume

TIME (min)	INFLOW [cfs]	STORAGE [cu ft]	STAGE [ft]	Skimmer Flow [cfs]	RISER CAPACIT Y [cfs]	WEIR FLOW [cfs]	BARREL CAPACITY [cfs]	TOTAL OUTFL OW [cfs]	Bound Discharge [cfs]	Estimated Surface Area (sf)	Settling Efficiency [%]
0	0.0	0	0.0	0.00	0.00	0.00	0.00	0.00	0.00	-	N/A
2	1.4	0	0.0	0.00	0.00	0.00	0.00	0.00	0.00	-	N/A
4	5.5	167	0.0	0.00	0.00	0.00	0.00	0.00	58.92	26,780	N/A
6	12.3	830	0.0	0.00	0.00	0.00	0.00	0.00	71.60	32,544	N/A
8	21.4	2,301	0.1	0.00	0.00	0.00	0.00	0.00	81.05	36,841	N/A
10	32.6	4,868	0.1	0.00	0.00	0.00	0.00	0.00	88.78	40,355	N/A
12	45.5	8,779	0.2	0.00	0.00	0.00	0.00	0.00	95.38	43,355	N/A
14	59.8	14,244	0.4	0.38	0.38	0.00	0.38	0.75	101.16	45,983	100%
16	74.9	21,327	0.5	0.38	0.38	0.00	0.38	0.75	106.25	48,297	100%
18	90.3	30,220	0.7	0.38	0.38	0.00	0.38	0.75	110.85	50,388	100%
20	105.6	40,965	0.9	0.38	0.38	0.00	0.38	0.75	115.03	52,287	100%
22	120.2	53,545	1.1	0.38	0.38	0.00	0.38	0.75	118.84	54,018	100%
24	133.7	67,882	1.4	0.38	0.38	0.00	0.38	0.75	122.32	55,600	100%
26	145.7	83,841	1.7	0.38	0.38	0.00	0.38	0.75	125.50	57,046	100%
28	155.7	101,234	2.0	0.38	0.38	0.00	0.38	0.75	128.41	58,369	100%
30	163.4	119,827	2.3	0.38	0.38	0.00	0.38	0.75	131.07	59,578	100%
32	168.6	139,348	2.6	0.38	0.38	0.00	0.38	0.75	133.50	60,681	100%
34	171.1	159,493	2.9	0.38	0.38	0.00	0.38	0.75	135.71	61,686	100%
36	170.9	179,939	3.3	0.38	0.38	0.00	0.38	0.75	137.71	62,598	100%
38	167.8	200,352	3.6	0.38	0.38	0.00	0.38	0.75	139.53	63,421	100%
40	162.1	220,399	3.9	0.38	0.38	0.00	0.38	0.75	141.15	64,161	100%
42	153.9	239,762	4.2	0.38	0.38	0.00	0.38	0.75	142.61	64,821	100%
44	143.8	258,141	4.5	0.38	0.38	0.00	0.38	0.75	143.89	65,406	100%
46	133.4	275,302	4.8	0.38	0.38	0.00	0.38	0.75	145.02	65,920	100%
48	123.8	291,222	5.0	0.38	0.38	0.00	0.38	0.75	146.02	66,372	100%
50	114.9	305,989	5.2	0.38	0.38	0.00	0.38	0.75	146.90	66,773	100%
52	106.6	319,686	5.4	0.38	0.38	0.00	0.38	0.75	147.68	67,129	100%
54	99.0	332,391	5.6	0.38	0.38	0.00	0.38	0.75	148.39	67,448	100%
56	91.8	344,175	5.8	0.38	0.38	0.00	0.38	0.75	149.02	67,735	100%
58	85.2	355,104	5.9	0.38	0.38	0.00	0.38	0.75	149.58	67,993	100%
60	79.1	365,240	6.1	0.38	0.38	0.00	0.38	0.75	150.10	68,226	100%
62	73.4	374,640	6.2	0.38	0.38	0.00	0.38	0.75	150.56	68,437	100%
64	68.1	383,357	6.4	0.38	0.38	0.00	0.38	0.75	150.98	68,629	100%
66	63.2	391,440	6.5	0.38	1.48	0.00	35.34	2.97	151.37	68,803	100%
68	58.7	398,668	6.6	0.38	4.40	0.00	35.68	8.80	151.70	68,956	100%
70	54.4	404,652	6.7	0.38	7.59	0.00	35.96	15.19	151.98	69,081	99%
72	50.5	409,362	6.7	0.38	10.51	0.00	36.17	21.01	152.19	69,179	98%
74	46.9	412,902	6.8	0.38	12.90	0.00	36.33	25.80	152.35	69,251	98%
76	43.5	415,432	6.8	0.38	14.71	0.00	36.45	29.42	152.47	69,303	97%
78	40.4	417,123	6.8	0.38	15.96	0.00	36.52	31.92	152.54	69,337	97%
80	37.5	418,137	6.9	0.38	16.73	0.00	36.57	33.46	152.59	69,357	96%
82	34.8	418,618	6.9	0.38	17.10	0.00	36.59	34.20	152.61	69,367	96%
84	32.3	418,687	6.9	0.38	17.15	0.00	36.60	34.30	152.61	69,368	96%

86	29.9	418,443	6.9	0.38	16.96	0.00	36.58	33.93	152.60	69,363	96%
88	27.8	417,965	6.9	0.38	16.60	0.00	36.56	33.20	152.58	69,354	96%
90	25.8	417,316	6.9	0.38	16.11	0.00	36.53	32.22	152.55	69,341	96%
92	23.9	416,545	6.8	0.38	15.53	0.00	36.50	31.06	152.52	69,325	97%
94	22.2	415,690	6.8	0.38	14.90	0.00	36.46	29.80	152.48	69,308	97%
96	20.6	414,780	6.8	0.38	14.23	0.00	36.42	28.47	152.44	69,289	97%
98	19.1	413,837	6.8	0.38	13.56	0.00	36.38	27.12	152.39	69,270	97%
100	17.8	412,878	6.8	0.38	12.88	0.00	36.33	25.77	152.35	69,251	98%
102	16.5	411,916	6.8	0.38	12.22	0.00	36.29	24.43	152.31	69,231	98%
104	15.3	410,961	6.8	0.38	11.57	0.00	36.25	23.13	152.27	69,211	98%
106	14.2	410,020	6.7	0.38	10.94	0.00	36.20	21.88	152.22	69,192	98%
108	13.2	409,097	6.7	0.38	10.33	0.00	36.16	20.67	152.18	69,173	98%
110	12.2	408,197	6.7	0.38	9.76	0.00	36.12	19.51	152.14	69,155	98%
112	11.3	407,322	6.7	0.38	9.20	0.00	36.08	18.41	152.10	69,137	99%
114	10.5	406,473	6.7	0.38	8.68	0.00	36.04	17.36	152.06	69,119	99%
116	9.8	405,652	6.7	0.38	8.18	0.00	36.00	16.37	152.02	69,102	99%
118	9.1	404,860	6.7	0.38	7.72	0.00	35.97	15.43	151.99	69,086	99%
120	8.4	404,096	6.7	0.38	7.27	0.00	35.93	14.54	151.95	69,070	99%
122	7.8	403,360	6.6	0.38	6.85	0.00	35.90	13.71	151.92	69,054	99%
124	7.2	402,652	6.6	0.38	6.46	0.00	35.87	12.92	151.89	69,040	99%
126	6.7	401,971	6.6	0.38	6.09	0.00	35.83	12.17	151.86	69,025	99%
128	6.2	401,317	6.6	0.38	5.74	0.00	35.80	11.47	151.83	69,012	99%
130	5.8	400,688	6.6	0.38	5.41	0.00	35.78	10.82	151.80	68,999	99%
132	5.4	400,085	6.6	0.38	5.10	0.00	35.75	10.20	151.77	68,986	100%
134	5.0	399,506	6.6	0.38	4.81	0.00	35.72	9.62	151.74	68,974	100%
136	4.6	398,950	6.6	0.38	4.54	0.00	35.69	9.07	151.72	68,962	100%
138	4.3	398,417	6.6	0.38	4.28	0.00	35.67	8.56	151.69	68,951	100%
140	4.0	397,905	6.6	0.38	4.04	0.00	35.65	8.08	151.67	68,940	100%
142	3.7	397,414	6.6	0.38	3.81	0.00	35.62	7.62	151.65	68,930	100%
144	3.4	396,943	6.6	0.38	3.60	0.00	35.60	7.20	151.62	68,920	100%
146	3.2	396,491	6.6	0.38	3.40	0.00	35.58	6.80	151.60	68,910	100%
148	3.0	396,058	6.5	0.38	3.21	0.00	35.56	6.42	151.58	68,901	100%
150	2.7	395,642	6.5	0.38	3.03	0.00	35.54	6.07	151.56	68,892	100%
152	2.5	395,243	6.5	0.38	2.87	0.00	35.52	5.74	151.54	68,884	100%
154	2.4	394,860	6.5	0.38	2.71	0.00	35.50	5.43	151.53	68,876	100%
156	2.2	394,492	6.5	0.38	2.57	0.00	35.49	5.13	151.51	68,868	100%
158	2.0	394,139	6.5	0.38	2.43	0.00	35.47	4.86	151.49	68,860	100%
160	1.9	393,800	6.5	0.38	2.30	0.00	35.46	4.60	151.48	68,853	100%
162	1.8	393,474	6.5	0.38	2.18	0.00	35.44	4.36	151.46	68,846	100%
164	1.6	393,161	6.5	0.38	2.07	0.00	35.43	4.13	151.45	68,840	100%
166	1.5	392,860	6.5	0.38	1.96	0.00	35.41	3.92	151.43	68,833	100%
168	1.4	392,572	6.5	0.38	1.86	0.00	35.40	3.71	151.42	68,827	100%
170	1.3	392,294	6.5	0.38	1.76	0.00	35.38	3.52	151.41	68,821	100%
172	1.2	392,027	6.5	0.38	1.67	0.00	35.37	3.35	151.39	68,816	100%
174	1.1	391,770	6.5	0.38	1.59	0.00	35.36	3.18	151.38	68,810	100%
176	1.0	391,523	6.5	0.38	1.51	0.00	35.35	3.02	151.37	68,805	100%
178	1.0	391,285	6.5	0.38	1.44	0.00	35.34	2.87	151.36	68,800	100%
180	0.9	391,056	6.5	0.38	1.37	0.00	35.33	2.73	151.35	68,795	100%
182	0.8	390,836	6.5	0.38	1.30	0.00	35.32	2.60	151.34	68,790	100%
184	0.8	390,623	6.5	0.38	1.24	0.00	35.31	2.48	151.33	68,785	100%
186	0.7	390,418	6.5	0.38	1.18	0.00	35.30	2.36	151.32	68,781	100%
188	0.7	390,221	6.5	0.38	1.12	0.00	35.29	2.25	151.31	68,777	100%
190	0.6	390,031	6.5	0.38	1.07	0.00	35.28	2.15	151.30	68,773	100%
192	0.6	389,847	6.5	0.38	1.02	0.00	35.27	2.05	151.29	68,769	100%
194	0.5	389,670	6.5	0.38	0.98	0.00	35.26	1.96	151.28	68,765	100%
196	0.5	389,498	6.4	0.38	0.94	0.00	35.25	1.87	151.28	68,761	100%
198	0.5	389,333	6.4	0.38	0.89	0.00	35.25	1.79	151.27	68,758	100%
200	0.4	389,173	6.4	0.38	0.86	0.00	35.24	1.71	151.26	68,754	100%
202	0.4	389,019	6.4	0.38	0.82	0.00	35.23	1.64	151.25	68,751	100%
204	0.4	388,869	6.4	0.38	0.79	0.00	35.22	1.57	151.25	68,748	100%
206	0.3	388,724	6.4	0.38	0.75	0.00	35.22	1.51	151.24	68,745	100%

Sediment Basin #7 Colon Mine Phase 2 Hydrograph 25-Yr Storm

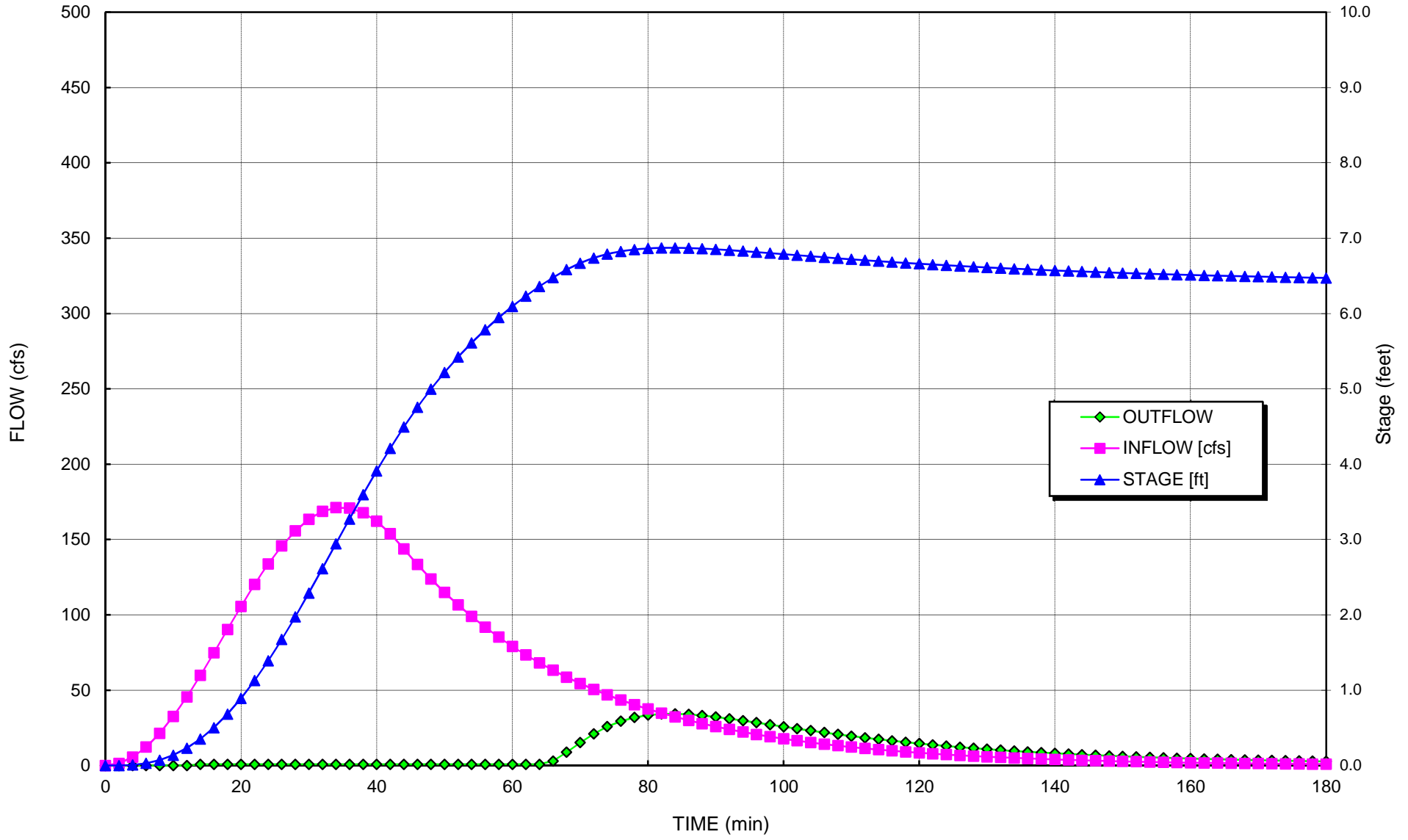

Qp = 230.4 cfs
 Tp = 35.2 minutes
 dT = Max of 2 minutes
 or 1.0% of increment to peak

Sediment Basin # 7 **Colon**
 Phase 2
100 - year Storm Event

b = 1.1
 Ks = 46,662

Number of Riser/Barrel Assemblies = 2
 Diameter of Barrel = 24 (in)
 Height of Riser above barrel = 4.4 (ft)
 Height of Riser from bottom of barrel = 6.4 (ft) elevation 244.40
 Emergency Spillway = 6.9 (ft) elevation 244.90
 Total Height of Dam = 7.5 (ft) elevation 245.50
 Length of Emergency Spillway = 20 (ft)
 Diameter of Riser = 60 (in)
 Permanent Pond Stage = 0 (ft) elevation 238.0

4.0E-03 Settling Velocity of design particle (fps)
 2 Effective number of cells (2 is construction site #)

83% Minimum Settling Efficiency	
7.4 ft Maximum Stage	245.4 msl elevation
97.5 cfs Peak outflow	
76.4 cfs Peak Riser/Barrel outflow	
21.1 cfs peak weir flow	

Notes:

1. Length of emergency spillway is the bottom width of the emergency spillway.
2. Settling efficiency neglects permanent pond volume

TIME (min)	INFLOW [cfs]	STORAGE [cu ft]	STAGE [ft]	Skimmer Flow [cfs]	RISER CAPACIT Y [cfs]	WEIR FLOW [cfs]	BARREL CAPACITY [cfs]	TOTAL OUTFLOW [cfs]	Bound Discharge [cfs]	Estimated Surface Area (sf)	Settling Efficiency [%]
0	0.0	0	0.0	0.00	0.00	0.00	0.00	0.00	0.00	-	N/A
2	1.8	0	0.0	0.00	0.00	0.00	0.00	0.00	0.00	-	N/A
4	7.3	220	0.0	0.00	0.00	0.00	0.00	0.00	60.91	27,686	N/A
6	16.1	1,091	0.0	0.00	0.00	0.00	0.00	0.00	74.02	33,645	N/A
8	28.1	3,027	0.1	0.00	0.00	0.00	0.00	0.00	83.80	38,089	N/A
10	42.9	6,403	0.2	0.00	0.00	0.00	0.00	0.00	91.79	41,723	N/A
12	60.0	11,554	0.3	0.00	0.00	0.00	0.00	0.00	98.62	44,828	N/A
14	78.8	18,753	0.4	0.38	0.38	0.00	0.38	0.75	104.60	47,547	100%
16	98.8	28,121	0.6	0.38	0.38	0.00	0.38	0.75	109.89	49,949	100%
18	119.3	39,888	0.9	0.38	0.38	0.00	0.38	0.75	114.66	52,118	100%
20	139.7	54,116	1.1	0.38	0.38	0.00	0.38	0.75	118.99	54,088	100%
22	159.3	70,788	1.4	0.38	0.38	0.00	0.38	0.75	122.94	55,884	100%
24	177.5	89,813	1.8	0.38	0.38	0.00	0.38	0.75	126.56	57,525	100%
26	193.7	111,021	2.1	0.38	0.38	0.00	0.38	0.75	129.86	59,027	100%
28	207.4	134,175	2.5	0.38	0.38	0.00	0.38	0.75	132.89	60,403	100%
30	218.2	158,976	2.9	0.38	0.38	0.00	0.38	0.75	135.66	61,662	100%
32	225.7	185,072	3.4	0.38	0.38	0.00	0.38	0.75	138.19	62,812	100%
34	229.7	212,070	3.8	0.38	0.38	0.00	0.38	0.75	140.49	63,861	100%
36	230.1	239,548	4.2	0.38	0.38	0.00	0.38	0.75	142.59	64,814	100%
38	226.8	267,070	4.6	0.38	0.38	0.00	0.38	0.75	144.49	65,677	100%
40	220.0	294,198	5.0	0.38	0.38	0.00	0.38	0.75	146.20	66,454	100%
42	209.8	320,505	5.4	0.38	0.38	0.00	0.38	0.75	147.73	67,150	100%
44	196.9	345,593	5.8	0.38	0.38	0.00	0.38	0.75	149.09	67,769	100%
46	182.9	369,129	6.2	0.38	0.38	0.00	0.38	0.75	150.29	68,314	100%
48	169.8	390,983	6.5	0.38	1.34	0.00	35.32	2.69	151.35	68,793	100%
50	157.8	411,042	6.8	0.38	11.62	0.00	36.25	23.24	152.27	69,213	98%
52	146.5	427,183	7.0	0.38	24.09	1.72	36.97	49.90	152.98	69,538	93%
54	136.1	438,778	7.2	0.38	34.73	7.96	37.48	77.42	153.48	69,765	87%
56	126.4	445,818	7.3	0.38	41.79	13.01	37.79	88.59	153.78	69,900	85%
58	117.4	450,355	7.3	0.38	46.55	16.67	37.99	92.64	153.97	69,986	84%
60	109.0	453,325	7.4	0.38	49.76	19.23	38.11	95.45	154.09	70,042	84%
62	101.3	454,956	7.4	0.38	51.56	20.68	38.18	97.04	154.16	70,073	83%
64	94.1	455,464	7.4	0.38	52.12	21.14	38.20	97.54	154.18	70,082	83%
66	87.4	455,047	7.4	0.38	51.66	20.76	38.19	97.13	154.16	70,074	83%
68	81.1	453,875	7.4	0.38	50.37	19.71	38.14	95.98	154.12	70,052	84%
70	75.4	452,095	7.4	0.38	48.43	18.15	38.06	94.27	154.04	70,019	84%
72	70.0	449,826	7.3	0.38	45.99	16.23	37.96	92.16	153.95	69,976	84%
74	65.0	447,168	7.3	0.38	43.19	14.07	37.85	89.77	153.84	69,926	85%
76	60.4	444,198	7.2	0.38	40.13	11.78	37.72	87.22	153.71	69,869	85%
78	56.1	440,978	7.2	0.38	36.89	9.45	37.58	83.23	153.58	69,807	86%
80	52.1	437,721	7.1	0.38	33.71	7.28	37.44	74.69	153.44	69,744	88%
82	48.4	435,009	7.1	0.38	31.13	5.61	37.32	67.88	153.32	69,692	89%
84	44.9	432,669	7.1	0.38	28.97	4.30	37.22	62.23	153.22	69,646	91%

86	41.7	430,594	7.0	0.38	27.09	3.23	37.13	57.41	153.13	69,605	92%
88	38.8	428,714	7.0	0.38	25.42	2.36	37.04	53.20	153.05	69,568	92%
90	36.0	426,982	7.0	0.38	23.92	1.64	36.97	49.47	152.97	69,534	93%
92	33.4	425,366	7.0	0.38	22.54	1.05	36.89	46.13	152.90	69,502	94%
94	31.1	423,843	6.9	0.38	21.27	0.58	36.83	43.12	152.84	69,472	94%
96	28.9	422,396	6.9	0.38	20.08	0.23	36.76	40.40	152.77	69,443	95%
98	26.8	421,010	6.9	0.38	18.97	0.02	36.70	37.96	152.71	69,415	95%
100	24.9	419,670	6.9	0.38	17.91	0.00	36.64	35.83	152.65	69,388	96%
102	23.1	418,357	6.9	0.38	16.90	0.00	36.58	33.80	152.60	69,362	96%
104	21.5	417,076	6.8	0.38	15.93	0.00	36.52	31.85	152.54	69,336	97%
106	19.9	415,829	6.8	0.38	15.00	0.00	36.47	30.00	152.48	69,311	97%
108	18.5	414,622	6.8	0.38	14.12	0.00	36.41	28.24	152.43	69,286	97%
110	17.2	413,456	6.8	0.38	13.29	0.00	36.36	26.58	152.38	69,262	97%
112	16.0	412,331	6.8	0.38	12.50	0.00	36.31	25.00	152.33	69,239	98%
114	14.8	411,247	6.8	0.38	11.76	0.00	36.26	23.52	152.28	69,217	98%
116	13.8	410,206	6.7	0.38	11.06	0.00	36.21	22.12	152.23	69,196	98%
118	12.8	409,205	6.7	0.38	10.40	0.00	36.17	20.81	152.19	69,175	98%
120	11.9	408,244	6.7	0.38	9.79	0.00	36.12	19.57	152.14	69,156	98%
122	11.0	407,322	6.7	0.38	9.21	0.00	36.08	18.41	152.10	69,137	99%
124	10.3	406,438	6.7	0.38	8.66	0.00	36.04	17.32	152.06	69,118	99%
126	9.5	405,591	6.7	0.38	8.15	0.00	36.00	16.30	152.02	69,101	99%
128	8.8	404,779	6.7	0.38	7.67	0.00	35.96	15.33	151.98	69,084	99%
130	8.2	404,000	6.7	0.38	7.22	0.00	35.93	14.43	151.95	69,068	99%
132	7.6	403,254	6.6	0.38	6.79	0.00	35.89	13.59	151.91	69,052	99%
134	7.1	402,540	6.6	0.38	6.40	0.00	35.86	12.79	151.88	69,037	99%
136	6.6	401,855	6.6	0.38	6.02	0.00	35.83	12.05	151.85	69,023	99%
138	6.1	401,200	6.6	0.38	5.68	0.00	35.80	11.35	151.82	69,009	99%
140	5.7	400,572	6.6	0.38	5.35	0.00	35.77	10.70	151.79	68,996	99%
142	5.3	399,970	6.6	0.38	5.04	0.00	35.74	10.08	151.76	68,984	100%
144	4.9	399,393	6.6	0.38	4.75	0.00	35.72	9.51	151.74	68,971	100%
146	4.6	398,841	6.6	0.38	4.48	0.00	35.69	8.96	151.71	68,960	100%
148	4.2	398,311	6.6	0.38	4.23	0.00	35.67	8.46	151.69	68,949	100%
150	3.9	397,803	6.6	0.38	3.99	0.00	35.64	7.98	151.66	68,938	100%
152	3.6	397,317	6.6	0.38	3.77	0.00	35.62	7.53	151.64	68,928	100%
154	3.4	396,851	6.6	0.38	3.56	0.00	35.60	7.11	151.62	68,918	100%
156	3.1	396,403	6.5	0.38	3.36	0.00	35.58	6.72	151.60	68,908	100%
158	2.9	395,974	6.5	0.38	3.18	0.00	35.56	6.35	151.58	68,899	100%
160	2.7	395,563	6.5	0.38	3.00	0.00	35.54	6.00	151.56	68,891	100%
162	2.5	395,168	6.5	0.38	2.84	0.00	35.52	5.68	151.54	68,882	100%
164	2.3	394,789	6.5	0.38	2.69	0.00	35.50	5.37	151.52	68,874	100%
166	2.2	394,426	6.5	0.38	2.54	0.00	35.48	5.08	151.51	68,867	100%
168	2.0	394,077	6.5	0.38	2.41	0.00	35.47	4.81	151.49	68,859	100%
170	1.9	393,742	6.5	0.38	2.28	0.00	35.45	4.56	151.47	68,852	100%
172	1.7	393,420	6.5	0.38	2.16	0.00	35.44	4.32	151.46	68,845	100%
174	1.6	393,111	6.5	0.38	2.05	0.00	35.42	4.09	151.44	68,839	100%
176	1.5	392,814	6.5	0.38	1.94	0.00	35.41	3.88	151.43	68,832	100%
178	1.4	392,528	6.5	0.38	1.84	0.00	35.40	3.68	151.42	68,826	100%
180	1.3	392,253	6.5	0.38	1.75	0.00	35.38	3.50	151.40	68,820	100%
182	1.2	391,989	6.5	0.38	1.66	0.00	35.37	3.32	151.39	68,815	100%
184	1.1	391,735	6.5	0.38	1.58	0.00	35.36	3.16	151.38	68,809	100%
186	1.0	391,491	6.5	0.38	1.50	0.00	35.35	3.00	151.37	68,804	100%
188	1.0	391,255	6.5	0.38	1.43	0.00	35.34	2.85	151.36	68,799	100%
190	0.9	391,029	6.5	0.38	1.36	0.00	35.33	2.72	151.35	68,794	100%
192	0.8	390,810	6.5	0.38	1.29	0.00	35.32	2.59	151.34	68,790	100%
194	0.8	390,600	6.5	0.38	1.23	0.00	35.31	2.46	151.33	68,785	100%
196	0.7	390,397	6.5	0.38	1.17	0.00	35.30	2.35	151.32	68,781	100%
198	0.7	390,202	6.5	0.38	1.12	0.00	35.29	2.24	151.31	68,776	100%
200	0.6	390,013	6.5	0.38	1.07	0.00	35.28	2.14	151.30	68,772	100%
202	0.6	389,831	6.5	0.38	1.02	0.00	35.27	2.04	151.29	68,769	100%
204	0.5	389,655	6.5	0.38	0.97	0.00	35.26	1.95	151.28	68,765	100%

**Sediment Basin #7 Colon Mine Phase 2 Hydrograph
100-Yr Storm**

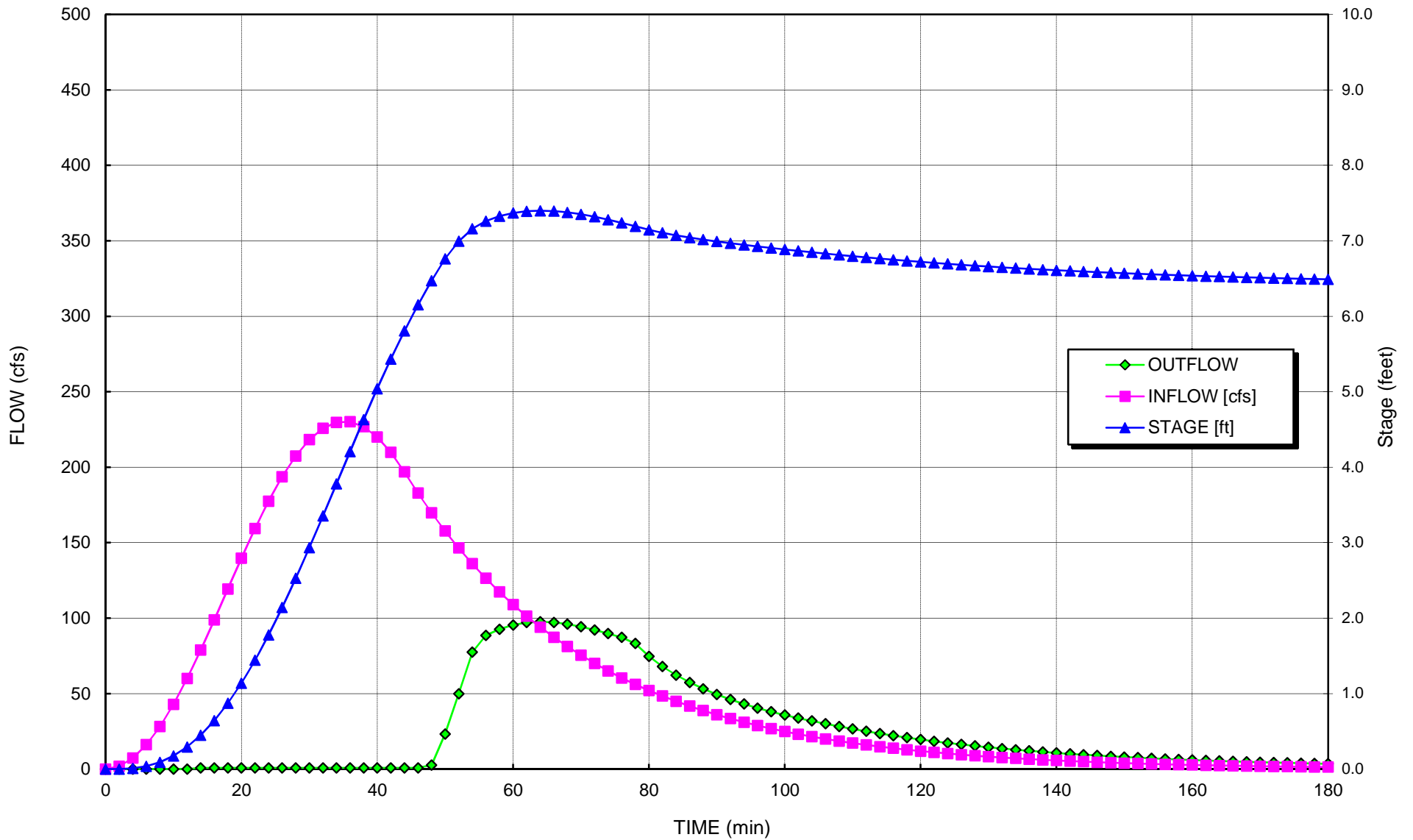

Project: Charah Colon Mine	Computed: PAW	Date: 3/4/15
Subject: Permit Application	Checked: MDP	Date: 3/6/15
Task: Sediment Basin #8	Sheet: 1	Of: 4

Objective Design the temporary sediment basin to contain the 25-year storm.

References

1. NC Erosion and Sediment Control Planning and Design Manual.
2. "Elements of Urban Stormwater Design" by H. Rooney Malcom, P.E.
3. NOAA Atlas 14, Volume 2, Version 3
4. VA Erosion and Sediment Control Handbook

Given

Phase	1	1		
Storm Event (yrs) =	10	25		
Total Drainage Area A (ac) =	11.8	11.8		
Disturbed Area (ac) =	11.8	11.8		
Curve Number CN =	86	86		
Rainfall Depth P (in) =	5.28	6.28	Hydrographs (24-hr rainfall)	Ref 3
Peak Flow Q _p (cfs) =	71.25	88.20	Hydrographs	

Design Criteria

Required sediment storage	1,800	cf / acre of drainage
Required sediment storage	21,240	cf
Required Surface Area	435	sf/cfs of the 10-yr storm peak flow (based on the largest Phase in cfs)
Required Surface Area (SF)	38,367	of the 10-yr storm peak flow (based on the largest Phase)

Determine Shape of Basin:

Measure the area of the Basin using AutoCADD.

Calculate Volume of the Basin using Truncated Pyramid Method.

Shape factor used in hydrographs basin depth may be greater than indicated below

Elevation (ft)	Depth (ft)	Area (sf)	Volume (cf)	Cumulative Vol (cf)	Cumulative Vol (cy)
273	0	5,639	-	-	-
274	1	18,291	11,362	11,362	421
275	2	28,277	23,103	34,465	1,276
276	3	38,333	33,178	67,643	2,505
277	4	47,710	42,936	110,579	4,096
278	5	59,010	53,260	163,839	6,068
279	6	69,292	64,082	227,922	8,442

Design Sediment Depth (ft) = 3

Sediment Storage (cf) = 67,643

Required Sediment Storage Achieved

Design Surface Area Depth (ft) = 3

Surface Area (sf) = 38,333

Increase Surface Area

Project: Charah Colon Mine	Computed: PAW	Date: 3/4/15
Subject: Permit Application	Checked: MDP	Date: 3/6/15
Task: Sediment Basin #8	Sheet: 2	Of: 4

Select Skimmer

A. R. Jarrett Method

$$D = [Q / (2,310 * (H^{0.5}))]^{0.5}$$

D = Diameter of Orifice (inches)
 Q = Dewater Rate (cf/day)
 H = Head on orifice, varies based on skimmer size (ft)

Skimmer Sizes (Inches)	Head (ft)
1.5	0.125
2	0.167
2.5	0.167
3	0.250
4	0.333
5	0.333
6	0.417
8	0.500

Volume to Dewater (cf) =	67,643	
Number of Skimmers	1	
Days to Drain =	5	<i>assumed</i>
Q each (cf/day) =	13,529	0.16 cfs

Selected Skimmer Size (inches) =	4
Head on Skimmer (feet) =	0.333
Diameter of Orifice (inches) =	3.2

Route the flow through the Basin

Riser is not perforated, but skimmer is attached.

$$S = (1000/CN) - 10$$

$$\text{Runoff Depth } Q^* \text{ (inches)} = (P-0.2S)^2 / (P+0.8S)$$

$$T_p \text{ (min)} = 60.5(Q^*)A/Q_p / 1.39$$

Ref 2, III-4

Phase	1	1
Storm Event (yrs) =	10	25
S =	1.63	1.63
Runoff Depth Q* (inches) =	3.73	4.68
Time to Peak T _p (min) =	26.88	27.23

Determine Pond Storage Elevation (Z_{water}):

Pick one point near max expected water surface and the other at the mid depth.

$$Z_1 \text{ (ft)} = 3 \quad S_1 \text{ (cf)} = 67,643$$

$$Z_2 \text{ (ft)} = 5 \quad S_2 \text{ (cf)} = 163,839$$

$$b = \ln(S_2/S_1) / \ln(Z_2/Z_1) = 1.7$$

$$K_S = S_2 / Z_2^b = 10,091$$

Ref 2, III-8

Project: Charah Colon Mine	Computed: PAW	Date: 3/4/15
Subject: Permit Application	Checked: MDP	Date: 3/6/15
Task: Sediment Basin #8	Sheet: 3	Of: 4

Determine Settling Velocity

Conversion Factor =	3.281 ft/sec per m/sec	
Gravitational Acceleration, g (m/s^2) =	9.81	
Specific Gravity of soil (s_s) =	2.6	
Kinematic Viscosity of water (ν) =	1.14E-06 m^2 / sec @ 20° C	Ref2, IV-11
Diameter of the Design Particle d_{15} =	40.00E-06 m	
Design Particle Settling Velocity =	$(g / 18) * [(s_s - 1) / \nu] d^2 =$	4.02E-03 ft/sec

Route the Storm through the Basin using the Hydrograph Model

Set Height of Emergency Spillway at (ft) = 5.30	<i>See Hydrograph</i>
Set Top of Dam at (ft) = 6.00	

Anti-Seep Collar:

Anti-Seep Collar Size = 2 * Barrel Dia
Anti-Seep Collar Size (ft) = 2
Use Anti-Seep Collar Size (ft) = 2 x 2

Minimum Concrete Base for Riser:

Diameter of Riser (in) = 18	From Hydrograph
Avg Density of Concrete (lbs/cf) = 87.6	
Density of Water (lbs/cf) = 62.4	
Riser Displacement (cf) = 7.95	$Pi * (D_R/24)^2 * Total\ Ht\ of\ Riser$
Convert cf to cy = 27 ⁻¹	
Min Concrete Needed (cy) = 0.21	
Width & Length (ft) = 2.5	
Thickness (ft) = 0.9	

Anti-Vortex Device:

Diameter of Riser (in) = 18	From Hydrograph	
Cylinder Diameter (in) = 27		Ref4, III-104, Table 3.14-D
Cylinder Thickness (gage) = 16		
Cylinder Height (in) = 8		

Project: Charah Colon Mine	Computed: PAW	Date: 3/4/15
Subject: Permit Application	Checked: MDP	Date: 3/6/15
Task: Sediment Basin #8	Sheet: 4	Of: 4

Determine Tailwater conditions to size outlet apron

Use Normal Depth Procedure (Manning's Eqn.)

Ref 2, II-7

$$A \cdot R^{2/3} = Q \cdot n / 1.49 s^{0.5}$$

$$Z_{req} = Q \cdot n / 1.49 s^{0.5}$$

$$\text{Area (A)} = bd + z(d^2)$$

$$R = \text{Area} / (b + 2d((z^2 + 1)^{0.5}))$$

$$Z_{av} = A \cdot R^{2/3}$$

- n = 0.069 6-inch diameter Rip Rap, Lined Channel
- V_p (ft/sec) = 9 Permissible Velocity for lining
- Side Slope (z) = 5 enter X for X:1
- s (ft/ft) = 0.02 Outlet Slope (estimated)
- Bottom Width (ft) = 6 6 * Barrel Diameter
- Q_B (cfs) = 2.6 Peak Flow out of the barrel 10-yr Hydrograph

Q (cfs)	Z _{req}	Flow Depth d (ft)	A (sf)	R (ft)	Z _{av}	V (ft/sec)
2.6	0.86	0.29	2.2	0.24	0.86	1.2

Flow Depth = Tailwater, d (ft) = 0.29 0.5 * Barrel Diameter (ft) = 0.50

Ref 1, 8.06.3

Minimum Tailwater Conditions: d < 0.5 * Diameter of Outlet Pipe

Maximum Tailwater Conditions: d > 0.5 * Diameter of Outlet Pipe

Since the Tailwater is less than half of the diameter of the outlet, use Minimum Tailwater conditions.

Barrel Diameter (ft)	Entrance (ft)	Length (ft)	Outlet Width (ft)	Median Rip Rap Size d ₅₀	Selected Rip Rap Size (in)
1	3	8	9	0.3	Class A

Conclusion

The temporary basin can contain the 25-yr storm.

HDR Computation

Project:	Charah Colon Mine	Computed: PAW	Date: 3/4/15
Subject:	Permit Application	Checked: MDP	Date: 3/6/15
Task:	Riser Pipe Perforations/Skimmer Flow	Sheet: 1	Of: 2

Diameter of Riser (in) = 18
 Circumference of Riser (in) = 56.5
 Height of Riser from bottom of barrel (in) = 54 From Hydrograph
 Vertical spacing between holes (in) = 0 center to center
 Water Stage increment (ft) 0.05

Orifice Equation

$$Q = C_d * A * (2 * g * h)^{0.5}$$

Ref 1, p III-11

Q = cfs, discharge
 C_d = 0.6 coefficient of discharge
 A = sf, cross sectional area
 g = 32.2 ft/sec², gravity
 h = ft, driving head measured from the center of the pipe

Row	Perforations					Skimmer	# of skimmers
	1	2	3	4	5	1	
Holes per row	0	0	0	0	0		
Hole Diameter (in)	0.75	0.75	0.75	0.75	0.75		
Spacing edge to edge (in)	#DIV/0!	#DIV/0!	#DIV/0!	#DIV/0!	#DIV/0!		
Inlet Area (sf)	0.000	0.000	0.000	0.000	0.000		
Hole Stage (in)	0.50	0.50	0.50	0.50	0.50		
Hole Stage (ft)	0.04	0.04	0.04	0.04	0.04		

Water Stage (ft)	Flow (cfs)	Flow (cfs)	Flow (cfs)	Flow (cfs)	Flow (cfs)	Flow (cfs)	Total Flow (cfs)
0.00	0.00	0.00	0.00			0.00	0.00
0.04	0.00	0.00	0.00			0.00	0.00
0.09	0.00	0.00	0.00			0.00	0.00
0.14	0.00	0.00	0.00			0.00	0.00
0.19	0.00	0.00	0.00			0.00	0.00
0.24	0.00	0.00	0.00			0.00	0.00
0.29	0.00	0.00	0.00			0.00	0.00
0.34	0.00	0.00	0.00			0.16	0.16
0.39	0.00	0.00	0.00			0.16	0.16
0.44	0.00	0.00	0.00			0.16	0.16
0.49	0.00	0.00	0.00			0.16	0.16
0.54	0.00	0.00	0.00			0.16	0.16
0.59	0.00	0.00	0.00			0.16	0.16
0.64	0.00	0.00	0.00			0.16	0.16
0.69	0.00	0.00	0.00			0.16	0.16
0.74	0.00	0.00	0.00			0.16	0.16
0.79	0.00	0.00	0.00			0.16	0.16
0.84	0.00	0.00	0.00			0.16	0.16
0.89	0.00	0.00	0.00			0.16	0.16
0.94	0.00	0.00	0.00			0.16	0.16
0.99	0.00	0.00	0.00			0.16	0.16
1.04	0.00	0.00	0.00			0.16	0.16
1.09	0.00	0.00	0.00			0.16	0.16
1.14	0.00	0.00	0.00			0.16	0.16
1.19	0.00	0.00	0.00			0.16	0.16
1.24	0.00	0.00	0.00			0.16	0.16
1.29	0.00	0.00	0.00			0.16	0.16
1.34	0.00	0.00	0.00			0.16	0.16
1.39	0.00	0.00	0.00			0.16	0.16
1.44	0.00	0.00	0.00			0.16	0.16
1.49	0.00	0.00	0.00			0.16	0.16
1.54	0.00	0.00	0.00			0.16	0.16
1.59	0.00	0.00	0.00			0.16	0.16

HDR Computation

Project:	Charah Colon Mine	Computed: PAW	Date: 3/4/15
Subject:	Permit Application	Checked: MDP	Date: 3/6/15
Task:	Riser Pipe Perforations/Skimmer Flow	Sheet: 2	Of: 2

1.64	0.00	0.00	0.00	0.16	0.16
1.69	0.00	0.00	0.00	0.16	0.16
1.74	0.00	0.00	0.00	0.16	0.16
1.79	0.00	0.00	0.00	0.16	0.16
1.84	0.00	0.00	0.00	0.16	0.16
1.89	0.00	0.00	0.00	0.16	0.16
1.94	0.00	0.00	0.00	0.16	0.16
1.99	0.00	0.00	0.00	0.16	0.16
2.04	0.00	0.00	0.00	0.16	0.16
2.09	0.00	0.00	0.00	0.16	0.16
2.14	0.00	0.00	0.00	0.16	0.16
2.19	0.00	0.00	0.00	0.16	0.16
2.24	0.00	0.00	0.00	0.16	0.16
2.29	0.00	0.00	0.00	0.16	0.16
2.34	0.00	0.00	0.00	0.16	0.16
2.39	0.00	0.00	0.00	0.16	0.16
2.44	0.00	0.00	0.00	0.16	0.16
2.49	0.00	0.00	0.00	0.16	0.16
2.54	0.00	0.00	0.00	0.16	0.16
2.59	0.00	0.00	0.00	0.16	0.16
2.64	0.00	0.00	0.00	0.16	0.16
2.69	0.00	0.00	0.00	0.16	0.16
2.74	0.00	0.00	0.00	0.16	0.16
2.79	0.00	0.00	0.00	0.16	0.16
2.84	0.00	0.00	0.00	0.16	0.16
2.89	0.00	0.00	0.00	0.16	0.16
2.94	0.00	0.00	0.00	0.16	0.16
2.99	0.00	0.00	0.00	0.16	0.16
3.04	0.00	0.00	0.00	0.16	0.16
3.09	0.00	0.00	0.00	0.16	0.16
3.14	0.00	0.00	0.00	0.16	0.16
3.19	0.00	0.00	0.00	0.16	0.16
3.24	0.00	0.00	0.00	0.16	0.16
3.29	0.00	0.00	0.00	0.16	0.16
3.34	0.00	0.00	0.00	0.16	0.16
3.39	0.00	0.00	0.00	0.16	0.16
3.44	0.00	0.00	0.00	0.16	0.16
3.49	0.00	0.00	0.00	0.16	0.16
3.54	0.00	0.00	0.00	0.16	0.16
3.59	0.00	0.00	0.00	0.16	0.16
3.64	0.00	0.00	0.00	0.16	0.16
3.69	0.00	0.00	0.00	0.16	0.16
3.74	0.00	0.00	0.00	0.16	0.16
3.79	0.00	0.00	0.00	0.16	0.16
3.84	0.00	0.00	0.00	0.16	0.16
3.89	0.00	0.00	0.00	0.16	0.16
3.94	0.00	0.00	0.00	0.16	0.16
3.99	0.00	0.00	0.00	0.16	0.16

Sediment Basin # 8 Colon

Qp = 71.25 cfs
 Tp = 26.88 minutes
 dT = Max of 2 minutes
 or 1.0% of increment to peak

Phase 1
 10 - year Storm Event

b = 1.7
 K_s = 10,091

Number of Riser/Barrel Assemblies = 1
 Diameter of Barrel = 12 (in)
 Height of Riser above barrel = 3.5 (ft)
 Height of Riser from bottom of barrel = 4.5 (ft) elevation 277.50
 Emergency Spillway = 5.3 (ft) elevation 278.30
 Total Height of Dam = 6.0 (ft) elevation 279.00
 Length of Emergency Spillway = 10 (ft)
 Diameter of Riser = 18 (in)
 Permanent Pond Stage = 0 (ft) elevation 273.0

4.0E-03 Settling Velocity of design particle (fps)
 2 Effective number of cells (2 is construction site #)
 100% Minimum Settling Efficiency
 4.8 ft Maximum Stage 277.79 msl elevation
 2.6 cfs Peak outflow
 2.6 cfs Peak Riser/Barrel outflow
 0.0 cfs Peak Weir flow

Notes:

1. Length of emergency spillway is the bottom width of the emergency spillway.
2. Settling efficiency neglects permanent pond volume

TIME	INFLOW	STORAGE	STAGE	Skimmer	RISER	WEIR	BARREL	TOTAL	Bound	Estimated	Settling
(min)	[cfs]	[cu ft]	[ft]	Flow [cfs]	CAPACIT	FLOW	CAPACITY	OUTFLOW	Discharge	Surface	Efficiency
					Y [cfs]	[cfs]	[cfs]	[cfs]	[cfs]	Area (sf)	[%]
0	0.0	0	0.0	0.00	0.00	0.00	0.00	0.00	0.00	-	N/A
2	1.0	0	0.0	0.00	0.00	0.00	0.00	0.00	0.00	-	N/A
4	3.8	116	0.1	0.00	0.00	0.00	0.00	0.00	5.83	2,650	N/A
6	8.4	575	0.2	0.00	0.00	0.00	0.00	0.00	11.46	5,208	N/A
8	14.5	1,584	0.3	0.16	0.16	0.00	0.16	0.16	17.58	7,991	100%
10	21.7	3,301	0.5	0.16	0.16	0.00	0.16	0.16	23.98	10,899	100%
12	29.7	5,884	0.7	0.16	0.16	0.00	0.16	0.16	30.61	13,914	100%
14	38.0	9,424	1.0	0.16	0.16	0.00	0.16	0.16	37.35	16,978	100%
16	46.1	13,960	1.2	0.16	0.16	0.00	0.16	0.16	44.10	20,045	100%
18	53.7	19,476	1.5	0.16	0.16	0.00	0.16	0.16	50.76	23,073	100%
20	60.3	25,904	1.7	0.16	0.16	0.00	0.16	0.16	57.26	26,028	100%
22	65.6	33,126	2.0	0.16	0.16	0.00	0.16	0.16	63.53	28,879	100%
24	69.2	40,980	2.2	0.16	0.16	0.00	0.16	0.16	69.51	31,595	100%
26	71.1	49,271	2.5	0.16	0.16	0.00	0.16	0.16	75.14	34,154	100%
28	70.9	57,780	2.7	0.16	0.16	0.00	0.16	0.16	80.37	36,532	100%
30	68.9	66,274	3.0	0.16	0.16	0.00	0.16	0.16	85.17	38,712	100%
32	65.1	74,525	3.2	0.16	0.16	0.00	0.16	0.16	89.50	40,680	100%
34	59.7	82,313	3.4	0.16	0.16	0.00	0.16	0.16	93.33	42,425	100%
36	54.2	89,462	3.5	0.16	0.16	0.00	0.16	0.16	96.68	43,944	100%
38	49.2	95,950	3.7	0.16	0.16	0.00	0.16	0.16	99.58	45,264	100%
40	44.7	101,837	3.8	0.16	0.16	0.00	0.16	0.16	102.12	46,417	100%
42	40.6	107,181	3.9	0.16	0.16	0.00	0.16	0.16	104.35	47,431	100%
44	36.8	112,029	4.0	0.16	0.16	0.00	0.16	0.16	106.32	48,326	100%
46	33.4	116,430	4.1	0.16	0.16	0.00	0.16	0.16	108.06	49,119	100%
48	30.3	120,422	4.2	0.16	0.16	0.00	0.16	0.16	109.61	49,824	100%
50	27.5	124,045	4.3	0.16	0.16	0.00	0.16	0.16	110.99	50,452	100%
52	25.0	127,333	4.3	0.16	0.16	0.00	0.16	0.16	112.23	51,013	100%
54	22.7	130,315	4.4	0.16	0.16	0.00	0.16	0.16	113.33	51,514	100%
56	20.6	133,021	4.4	0.16	0.16	0.00	0.16	0.16	114.32	51,964	100%
58	18.7	135,475	4.5	0.16	0.16	0.00	0.16	0.16	115.21	52,367	100%
60	17.0	137,702	4.5	0.16	0.21	0.00	7.57	0.21	116.00	52,729	100%
62	15.4	139,715	4.6	0.16	0.39	0.00	7.61	0.39	116.72	53,053	100%
64	14.0	141,519	4.6	0.16	0.61	0.00	7.64	0.61	117.35	53,341	100%
66	12.7	143,125	4.6	0.16	0.84	0.00	7.67	0.84	117.91	53,597	100%
68	11.5	144,549	4.7	0.16	1.07	0.00	7.69	1.07	118.41	53,821	100%
70	10.5	145,805	4.7	0.16	1.29	0.00	7.71	1.29	118.84	54,018	100%
72	9.5	146,907	4.7	0.16	1.49	0.00	7.73	1.49	119.22	54,190	100%
74	8.6	147,869	4.7	0.16	1.68	0.00	7.75	1.68	119.55	54,340	100%
76	7.8	148,703	4.7	0.16	1.85	0.00	7.76	1.85	119.83	54,469	100%
78	7.1	149,422	4.7	0.16	2.00	0.00	7.78	2.00	120.08	54,580	100%
80	6.5	150,036	4.8	0.16	2.13	0.00	7.79	2.13	120.29	54,675	100%
82	5.9	150,555	4.8	0.16	2.24	0.00	7.79	2.24	120.46	54,755	100%

84	5.3	150,990	4.8	0.16	2.33	0.00	7.80	2.33	120.61	54,822	100%
86	4.8	151,348	4.8	0.16	2.41	0.00	7.81	2.41	120.73	54,877	100%
88	4.4	151,638	4.8	0.16	2.48	0.00	7.81	2.48	120.83	54,921	100%
90	4.0	151,867	4.8	0.16	2.53	0.00	7.82	2.53	120.90	54,956	100%
92	3.6	152,041	4.8	0.16	2.57	0.00	7.82	2.57	120.96	54,983	100%
94	3.3	152,166	4.8	0.16	2.60	0.00	7.82	2.60	121.00	55,002	100%
96	3.0	152,248	4.8	0.16	2.62	0.00	7.82	2.62	121.03	55,014	100%
98	2.7	152,292	4.8	0.16	2.63	0.00	7.82	2.63	121.05	55,021	100%
100	2.5	152,301	4.8	0.16	2.63	0.00	7.82	2.63	121.05	55,022	100%
102	2.2	152,280	4.8	0.16	2.62	0.00	7.82	2.62	121.04	55,019	100%
104	2.0	152,232	4.8	0.16	2.61	0.00	7.82	2.61	121.03	55,012	100%
106	1.8	152,161	4.8	0.16	2.60	0.00	7.82	2.60	121.00	55,001	100%
108	1.7	152,070	4.8	0.16	2.58	0.00	7.82	2.58	120.97	54,987	100%
110	1.5	151,961	4.8	0.16	2.55	0.00	7.82	2.55	120.93	54,970	100%
112	1.4	151,836	4.8	0.16	2.52	0.00	7.82	2.52	120.89	54,951	100%
114	1.2	151,698	4.8	0.16	2.49	0.00	7.81	2.49	120.85	54,930	100%
116	1.1	151,549	4.8	0.16	2.46	0.00	7.81	2.46	120.80	54,907	100%
118	1.0	151,389	4.8	0.16	2.42	0.00	7.81	2.42	120.74	54,883	100%
120	0.9	151,222	4.8	0.16	2.39	0.00	7.81	2.39	120.69	54,857	100%
122	0.8	151,048	4.8	0.16	2.35	0.00	7.80	2.35	120.63	54,831	100%
124	0.8	150,868	4.8	0.16	2.31	0.00	7.80	2.31	120.57	54,803	100%
126	0.7	150,683	4.8	0.16	2.27	0.00	7.80	2.27	120.50	54,775	100%
128	0.6	150,495	4.8	0.16	2.23	0.00	7.79	2.23	120.44	54,746	100%
130	0.6	150,304	4.8	0.16	2.18	0.00	7.79	2.18	120.38	54,716	100%
132	0.5	150,111	4.8	0.16	2.14	0.00	7.79	2.14	120.31	54,687	100%
134	0.5	149,916	4.8	0.16	2.10	0.00	7.78	2.10	120.24	54,657	100%
136	0.4	149,721	4.7	0.16	2.06	0.00	7.78	2.06	120.18	54,627	100%
138	0.4	149,525	4.7	0.16	2.02	0.00	7.78	2.02	120.11	54,596	100%
140	0.4	149,330	4.7	0.16	1.98	0.00	7.77	1.98	120.05	54,566	100%
142	0.3	149,135	4.7	0.16	1.94	0.00	7.77	1.94	119.98	54,536	100%
144	0.3	148,942	4.7	0.16	1.90	0.00	7.77	1.90	119.91	54,506	100%
146	0.3	148,749	4.7	0.16	1.86	0.00	7.76	1.86	119.85	54,477	100%
148	0.2	148,558	4.7	0.16	1.82	0.00	7.76	1.82	119.78	54,447	100%
150	0.2	148,369	4.7	0.16	1.78	0.00	7.76	1.78	119.72	54,418	100%
152	0.2	148,182	4.7	0.16	1.74	0.00	7.75	1.74	119.65	54,389	100%
154	0.2	147,996	4.7	0.16	1.71	0.00	7.75	1.71	119.59	54,360	100%
156	0.2	147,813	4.7	0.16	1.67	0.00	7.75	1.67	119.53	54,331	100%
158	0.1	147,633	4.7	0.16	1.63	0.00	7.75	1.63	119.47	54,303	100%
160	0.1	147,455	4.7	0.16	1.60	0.00	7.74	1.60	119.41	54,276	100%
162	0.1	147,279	4.7	0.16	1.56	0.00	7.74	1.56	119.35	54,248	100%
164	0.1	147,106	4.7	0.16	1.53	0.00	7.74	1.53	119.29	54,221	100%
166	0.1	146,935	4.7	0.16	1.50	0.00	7.73	1.50	119.23	54,195	100%
168	0.1	146,768	4.7	0.16	1.47	0.00	7.73	1.47	119.17	54,169	100%
170	0.1	146,603	4.7	0.16	1.44	0.00	7.73	1.44	119.11	54,143	100%
172	0.1	146,440	4.7	0.16	1.41	0.00	7.73	1.41	119.06	54,118	100%
174	0.1	146,281	4.7	0.16	1.38	0.00	7.72	1.38	119.00	54,093	100%
176	0.1	146,124	4.7	0.16	1.35	0.00	7.72	1.35	118.95	54,068	100%
178	0.1	145,970	4.7	0.16	1.32	0.00	7.72	1.32	118.90	54,044	100%
180	0.1	145,818	4.7	0.16	1.29	0.00	7.71	1.29	118.84	54,020	100%
182	0.0	145,669	4.7	0.16	1.26	0.00	7.71	1.26	118.79	53,997	100%
184	0.0	145,523	4.7	0.16	1.24	0.00	7.71	1.24	118.74	53,974	100%
186	0.0	145,380	4.7	0.16	1.21	0.00	7.71	1.21	118.69	53,952	100%
188	0.0	145,239	4.7	0.16	1.19	0.00	7.70	1.19	118.64	53,930	100%
190	0.0	145,100	4.7	0.16	1.16	0.00	7.70	1.16	118.60	53,908	100%
192	0.0	144,964	4.7	0.16	1.14	0.00	7.70	1.14	118.55	53,886	100%
194	0.0	144,831	4.7	0.16	1.12	0.00	7.70	1.12	118.50	53,865	100%
196	0.0	144,700	4.7	0.16	1.10	0.00	7.70	1.10	118.46	53,845	100%
198	0.0	144,571	4.7	0.16	1.07	0.00	7.69	1.07	118.41	53,825	100%
200	0.0	144,445	4.6	0.16	1.05	0.00	7.69	1.05	118.37	53,805	100%
202	0.0	144,321	4.6	0.16	1.03	0.00	7.69	1.03	118.33	53,785	100%
204	0.0	144,199	4.6	0.16	1.01	0.00	7.69	1.01	118.29	53,766	100%
206	0.0	144,080	4.6	0.16	0.99	0.00	7.68	0.99	118.24	53,747	100%

**Sediment Basin #8 Colon Mine Phase 1 Hydrograph
10-Yr Storm**

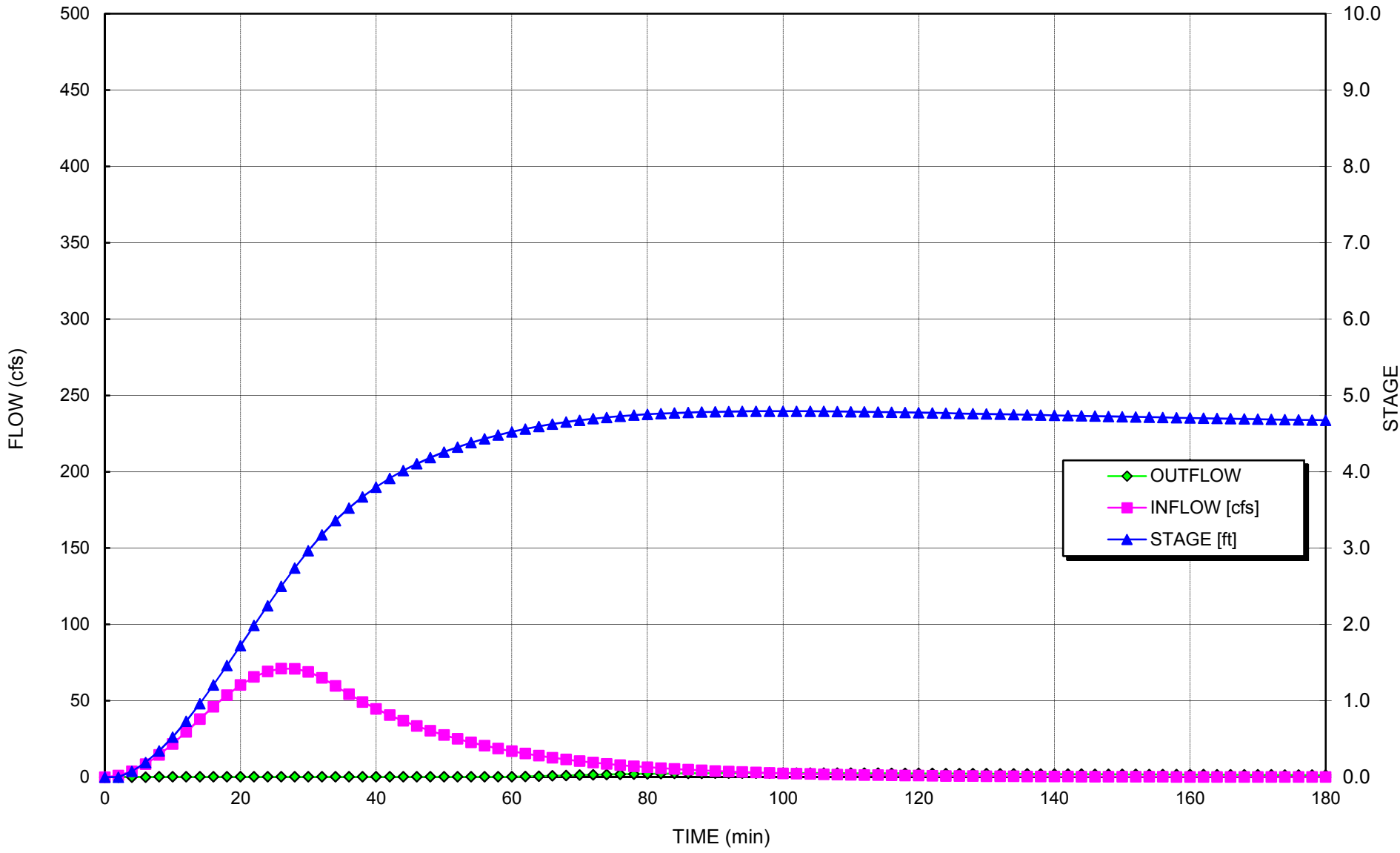

This page intentionally left blank.

Sediment Basin # 8 Colon

Qp = 88.20 cfs
 Tp = 27.23 minutes
 dT = Max of 2 minutes
 or 1.0% of increment to peak

Phase 1
 25 - year Storm Event

b = 1.7
 K_s = 10,091

Number of Riser/Barrel Assemblies = 1
 Diameter of Barrel = 12 (in)
 Height of Riser above barrel = 3.5 (ft)
 Height of Riser from bottom of barrel = 4.5 (ft) elevation 277.50
 Emergency Spillway = 5.3 (ft) elevation 278.30
 Total Height of Dam = 6.0 (ft) elevation 279.00
 Length of Emergency Spillway = 10 (ft)
 Diameter of Riser = 18 (in)
 Permanent Pond Stage = 0 (ft) elevation 273.0

4.0E-03 Settling Velocity of design particle (fps)
 2 Effective number of cells (2 is construction site #)
 100% Minimum Settling Efficiency
 5.2 ft Maximum Stage 278.22 msl elevation
 8.2 cfs Peak outflow
 8.2 cfs Peak Riser/Barrel outflow
 0.0 cfs Peak Weir flow

Notes:

1. Length of emergency spillway is the bottom width of the emergency spillway.
2. Settling efficiency neglects permanent pond volume

TIME	INFLOW	STORAGE	STAGE	Skimmer	RISER	WEIR	BARREL	TOTAL	Bound	Estimated	Settling
(min)	[cfs]	[cu ft]	[ft]	Flow [cfs]	CAPACIT	FLOW	CAPACITY	OUTFLOW	Discharge	Surface	Efficiency
					Y [cfs]	[cfs]	[cfs]	[cfs]	[cfs]	Area (sf)	[%]
0	0.0	0	0.0	0.00	0.00	0.00	0.00	0.00	0.00	-	N/A
2	1.2	0	0.0	0.00	0.00	0.00	0.00	0.00	0.00	-	N/A
4	4.6	140	0.1	0.00	0.00	0.00	0.00	0.00	6.31	2,869	N/A
6	10.2	694	0.2	0.00	0.00	0.00	0.00	0.00	12.40	5,638	N/A
8	17.5	1,912	0.4	0.16	0.16	0.00	0.16	0.16	19.04	8,653	100%
10	26.2	3,992	0.6	0.16	0.16	0.00	0.16	0.16	25.98	11,810	100%
12	35.9	7,122	0.8	0.16	0.16	0.00	0.16	0.16	33.18	15,083	100%
14	46.1	11,415	1.1	0.16	0.16	0.00	0.16	0.16	40.50	18,410	100%
16	56.1	16,923	1.3	0.16	0.16	0.00	0.16	0.16	47.84	21,743	100%
18	65.5	23,635	1.6	0.16	0.16	0.00	0.16	0.16	55.09	25,039	100%
20	73.7	31,473	1.9	0.16	0.16	0.00	0.16	0.16	62.17	28,261	100%
22	80.4	40,302	2.2	0.16	0.16	0.00	0.16	0.16	69.02	31,373	100%
24	85.2	49,933	2.5	0.16	0.16	0.00	0.16	0.16	75.56	34,347	100%
26	87.8	60,135	2.8	0.16	0.16	0.00	0.16	0.16	81.74	37,154	100%
28	88.0	70,647	3.1	0.16	0.16	0.00	0.16	0.16	87.50	39,771	100%
30	86.0	81,191	3.3	0.16	0.16	0.00	0.16	0.16	92.79	42,179	100%
32	81.7	91,488	3.6	0.16	0.16	0.00	0.16	0.16	97.60	44,362	100%
34	75.4	101,272	3.8	0.16	0.16	0.00	0.16	0.16	101.88	46,308	100%
36	68.6	110,303	4.0	0.16	0.16	0.00	0.16	0.16	105.62	48,010	100%
38	62.4	118,519	4.1	0.16	0.16	0.00	0.16	0.16	108.88	49,490	100%
40	56.7	125,986	4.3	0.16	0.16	0.00	0.16	0.16	111.73	50,784	100%
42	51.5	132,771	4.4	0.16	0.16	0.00	0.16	0.16	114.23	51,923	100%
44	46.8	138,937	4.5	0.16	0.31	0.00	7.59	0.31	116.44	52,928	100%
46	42.6	144,520	4.7	0.16	1.07	0.00	7.69	1.07	118.40	53,817	100%
48	38.7	149,502	4.7	0.16	2.01	0.00	7.78	2.01	120.10	54,593	100%
50	35.2	153,904	4.8	0.16	3.01	0.00	7.85	3.01	121.59	55,266	100%
52	32.0	157,764	4.9	0.16	3.97	0.00	7.91	3.97	122.87	55,848	100%
54	29.1	161,124	5.0	0.16	4.88	0.00	7.97	4.88	123.96	56,347	100%
56	26.4	164,025	5.0	0.16	5.71	0.00	8.01	5.71	124.90	56,774	100%
58	24.0	166,509	5.0	0.16	6.45	0.00	8.05	6.45	125.70	57,136	100%
60	21.8	168,617	5.1	0.16	7.09	0.00	8.08	7.09	126.37	57,440	100%
62	19.8	170,384	5.1	0.16	7.65	0.00	8.11	7.65	126.93	57,694	100%
64	18.0	171,847	5.1	0.16	8.11	0.00	8.13	8.11	127.39	57,903	100%
66	16.4	173,037	5.2	0.16	8.50	0.00	8.15	8.15	127.76	58,072	100%
68	14.9	174,025	5.2	0.16	8.82	0.00	8.17	8.17	128.07	58,212	100%
70	13.5	174,832	5.2	0.16	9.09	0.00	8.18	8.18	128.32	58,326	100%
72	12.3	175,476	5.2	0.16	9.30	0.00	8.19	8.19	128.52	58,416	100%
74	11.2	175,970	5.2	0.16	9.47	0.00	8.19	8.19	128.67	58,486	100%
76	10.2	176,328	5.2	0.16	9.59	0.00	8.20	8.20	128.78	58,536	100%
78	9.2	176,564	5.2	0.16	9.67	0.00	8.20	8.20	128.85	58,569	100%
80	8.4	176,688	5.2	0.16	9.71	0.00	8.21	8.21	128.89	58,586	100%
82	7.6	176,712	5.2	0.16	9.72	0.00	8.21	8.21	128.90	58,590	100%

84	6.9	176,643	5.2	0.16	9.70	0.00	8.20	8.20	128.88	58,580	100%
86	6.3	176,491	5.2	0.16	9.65	0.00	8.20	8.20	128.83	58,559	100%
88	5.7	176,263	5.2	0.16	9.57	0.00	8.20	8.20	128.76	58,527	100%
90	5.2	175,967	5.2	0.16	9.47	0.00	8.19	8.19	128.67	58,485	100%
92	4.7	175,609	5.2	0.16	9.35	0.00	8.19	8.19	128.56	58,435	100%
94	4.3	175,195	5.2	0.16	9.21	0.00	8.18	8.18	128.43	58,377	100%
96	3.9	174,729	5.2	0.16	9.06	0.00	8.18	8.18	128.28	58,311	100%
98	3.6	174,218	5.2	0.16	8.89	0.00	8.17	8.17	128.13	58,239	100%
100	3.2	173,664	5.2	0.16	8.70	0.00	8.16	8.16	127.95	58,161	100%
102	2.9	173,073	5.2	0.16	8.51	0.00	8.15	8.15	127.77	58,077	100%
104	2.7	172,447	5.2	0.16	8.31	0.00	8.14	8.14	127.57	57,988	100%
106	2.4	171,791	5.1	0.16	8.09	0.00	8.13	8.09	127.37	57,895	100%
108	2.2	171,110	5.1	0.16	7.88	0.00	8.12	7.88	127.15	57,798	100%
110	2.0	170,430	5.1	0.16	7.66	0.00	8.11	7.66	126.94	57,700	100%
112	1.8	169,751	5.1	0.16	7.45	0.00	8.10	7.45	126.73	57,603	100%
114	1.7	169,077	5.1	0.16	7.23	0.00	8.09	7.23	126.51	57,506	100%
116	1.5	168,407	5.1	0.16	7.03	0.00	8.08	7.03	126.30	57,410	100%
118	1.4	167,745	5.1	0.16	6.82	0.00	8.07	6.82	126.09	57,315	100%
120	1.2	167,090	5.1	0.16	6.62	0.00	8.06	6.62	125.88	57,220	100%
122	1.1	166,445	5.0	0.16	6.43	0.00	8.05	6.43	125.68	57,126	100%
124	1.0	165,810	5.0	0.16	6.24	0.00	8.04	6.24	125.48	57,034	100%
126	0.9	165,185	5.0	0.16	6.05	0.00	8.03	6.05	125.28	56,943	100%
128	0.8	164,571	5.0	0.16	5.87	0.00	8.02	5.87	125.08	56,854	100%
130	0.8	163,968	5.0	0.16	5.69	0.00	8.01	5.69	124.88	56,766	100%
132	0.7	163,378	5.0	0.16	5.52	0.00	8.00	5.52	124.69	56,679	100%
134	0.6	162,800	5.0	0.16	5.35	0.00	7.99	5.35	124.51	56,594	100%
136	0.6	162,234	5.0	0.16	5.19	0.00	7.98	5.19	124.32	56,511	100%
138	0.5	161,680	5.0	0.16	5.04	0.00	7.98	5.04	124.15	56,430	100%
140	0.5	161,139	5.0	0.16	4.89	0.00	7.97	4.89	123.97	56,350	100%
142	0.4	160,610	4.9	0.16	4.74	0.00	7.96	4.74	123.80	56,271	100%
144	0.4	160,093	4.9	0.16	4.60	0.00	7.95	4.60	123.63	56,195	100%
146	0.4	159,589	4.9	0.16	4.46	0.00	7.94	4.46	123.46	56,120	100%
148	0.3	159,097	4.9	0.16	4.33	0.00	7.93	4.33	123.30	56,047	100%
150	0.3	158,617	4.9	0.16	4.20	0.00	7.93	4.20	123.15	55,975	100%
152	0.3	158,148	4.9	0.16	4.08	0.00	7.92	4.08	122.99	55,905	100%
154	0.2	157,692	4.9	0.16	3.96	0.00	7.91	3.96	122.84	55,837	100%
156	0.2	157,247	4.9	0.16	3.84	0.00	7.90	3.84	122.70	55,770	100%
158	0.2	156,813	4.9	0.16	3.73	0.00	7.90	3.73	122.55	55,705	100%
160	0.2	156,389	4.9	0.16	3.62	0.00	7.89	3.62	122.41	55,642	100%
162	0.2	155,977	4.9	0.16	3.52	0.00	7.88	3.52	122.28	55,580	100%
164	0.2	155,575	4.9	0.16	3.42	0.00	7.88	3.42	122.14	55,519	100%
166	0.1	155,184	4.8	0.16	3.32	0.00	7.87	3.32	122.01	55,460	100%
168	0.1	154,802	4.8	0.16	3.22	0.00	7.86	3.22	121.89	55,403	100%
170	0.1	154,431	4.8	0.16	3.13	0.00	7.86	3.13	121.76	55,346	100%
172	0.1	154,068	4.8	0.16	3.05	0.00	7.85	3.05	121.64	55,291	100%
174	0.1	153,715	4.8	0.16	2.96	0.00	7.85	2.96	121.52	55,238	100%
176	0.1	153,371	4.8	0.16	2.88	0.00	7.84	2.88	121.41	55,186	100%
178	0.1	153,036	4.8	0.16	2.80	0.00	7.84	2.80	121.30	55,135	100%
180	0.1	152,709	4.8	0.16	2.72	0.00	7.83	2.72	121.19	55,085	100%
182	0.1	152,391	4.8	0.16	2.65	0.00	7.83	2.65	121.08	55,036	100%
184	0.1	152,081	4.8	0.16	2.58	0.00	7.82	2.58	120.98	54,989	100%
186	0.1	151,778	4.8	0.16	2.51	0.00	7.81	2.51	120.87	54,943	100%
188	0.0	151,483	4.8	0.16	2.44	0.00	7.81	2.44	120.77	54,897	100%
190	0.0	151,196	4.8	0.16	2.38	0.00	7.81	2.38	120.68	54,853	100%
192	0.0	150,916	4.8	0.16	2.32	0.00	7.80	2.32	120.58	54,810	100%
194	0.0	150,642	4.8	0.16	2.26	0.00	7.80	2.26	120.49	54,768	100%
196	0.0	150,376	4.8	0.16	2.20	0.00	7.79	2.20	120.40	54,727	100%
198	0.0	150,116	4.8	0.16	2.14	0.00	7.79	2.14	120.31	54,687	100%
200	0.0	149,862	4.7	0.16	2.09	0.00	7.78	2.09	120.23	54,648	100%
202	0.0	149,614	4.7	0.16	2.04	0.00	7.78	2.04	120.14	54,610	100%
204	0.0	149,373	4.7	0.16	1.99	0.00	7.77	1.99	120.06	54,573	100%
206	0.0	149,137	4.7	0.16	1.94	0.00	7.77	1.94	119.98	54,537	100%

**Sediment Basin #8 Colon Mine Phase 1 Hydrograph
25-Yr Storm**

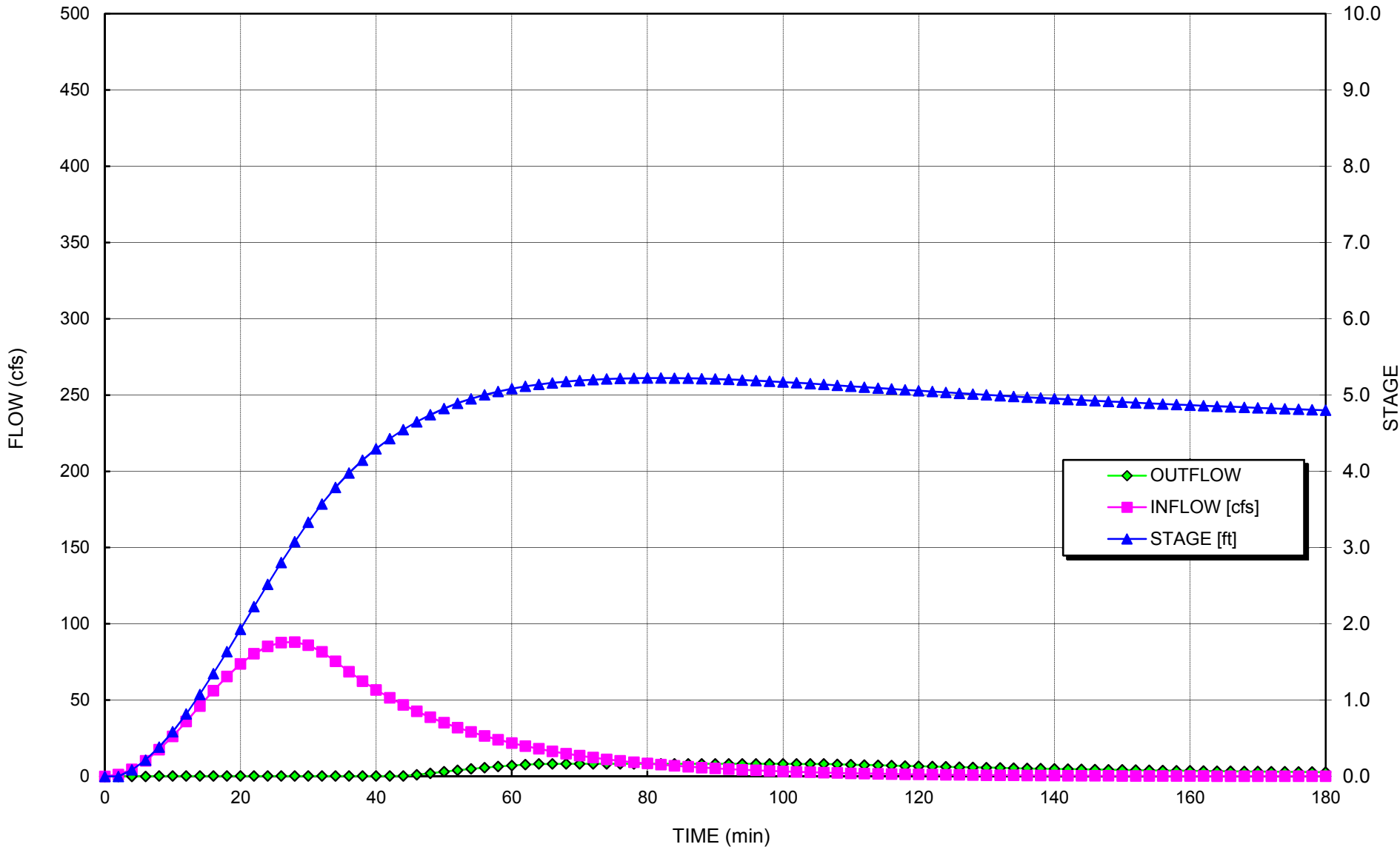

This page intentionally left blank.

Project: Charah Colon Mine	Computed: PAW	Date: 3/5/15
Subject: Permit Application	Checked: MDP	Date: 3/6/15
Task: Sediment Basin #9	Sheet: 1	Of: 4

Objective Design the sediment basin to contain the 25-year storm and pass the 100-year storm without over topping the berm.

References

1. NC Erosion and Sediment Control Planning and Design Manual.
2. "Elements of Urban Stormwater Design" by H. Rooney Malcom, P.E.
3. NOAA Atlas 14, Volume 2, Version 3
4. VA Erosion and Sediment Control Handbook

Given

Phase	1	2	2	2		
Storm Event (yrs) =	10	10	25	100		
Total Drainage Area A (ac) =	62.8	85.9	85.9	85.9		
Disturbed Area (ac) =	46.7	65.9	65.9	65.9		
Curve Number CN =	72	72	72	72	Hydrographs	
Rainfall Depth P (in) =	5.28	5.28	6.28	7.88	(24-hr rainfall)	Ref 3
Peak Flow Q _p (cfs) =	145.70	199.50	268.73	384.06	Hydrographs	

Design Criteria

Required sediment storage	1,800	cf / acre of drainage
Required sediment storage	154,620	cf (based on largest Phase)
Required Surface Area	435	sf/cfs of the 10-yr storm peak flow (based on the largest Phase in cfs)
Required Surface Area (SF)	86,783	of the 10-yr storm peak flow (based on the largest Phase)

Determine Shape of Basin:

Measure the area of the Basin using AutoCADD.

Calculate Volume of the Basin using Truncated Pyramid Method.

Shape factor used in hydrographs basin depth may be greater than indicated below

Elevation (ft)	Depth (ft)	Area (sf)	Volume (cf)	Cumulative Vol (cf)	Cumulative Vol (cy)
262	0	88,670	0	0	0
263	1	92,409	90,533	90,533	3,353
264	2	96,226	94,311	184,844	6,846
265	3	100,091	98,152	282,996	10,481
266	4	103,992	102,035	385,032	14,260
267	5	107,938	105,959	490,990	18,185
268	6	111,933	109,929	600,920	22,256

Design Sediment Depth (ft) = 3
 Sediment Storage (cf) = 282,996 *Required Sediment Storage Achieved*

Design Surface Area Depth (ft) = 3
 Surface Area (sf) = 100,091 *Required Surface Area Achieved*

Project: Charah Colon Mine	Computed: PAW	Date: 3/5/15
Subject: Permit Application	Checked: MDP	Date: 3/6/15
Task: Sediment Basin #9	Sheet: 2	Of: 4

Select Skimmer

A. R. Jarrett Method

$$D = [Q / (2,310 * (H^{0.5}))^{0.5}$$

D = Diameter of Orifice (inches)
 Q = Dewater Rate (cf/day)
 H = Head on orifice, varies based on skimmer size (ft)

Skimmer Sizes (Inches)	Head (ft)
1.5	0.125
2	0.167
2.5	0.167
3	0.250
4	0.333
5	0.333
6	0.417
8	0.500

Volume to Dewater (cf) =	282,996		
Number of Skimmers	2		
Days to Drain =	5	<i>assumed</i>	
Q each (cf/day) =	28,300		0.33 cfs

Selected Skimmer Size (inches) =	5
Head on Skimmer (feet) =	0.333
Diameter of Orifice (inches) =	4.6

Route the flow through the Basin

Riser is not perforated, but skimmer is attached.

$$S = (1000/CN) - 10$$

$$\text{Runoff Depth } Q^* \text{ (inches)} = (P-0.2S)^2 / (P+0.8S)$$

$$T_p \text{ (min)} = 60.5(Q^*)A/Q_p / 1.39$$

Ref 2, III-4

	1	2	2	2
Storm Event (yrs) =	10	10	25	100
S =	3.89	3.89	3.89	3.89
Runoff Depth Q* (inches) =	2.42	2.42	3.22	4.59
Time to Peak T _p (min) =	45.32	45.27	44.85	44.68

Determine Pond Storage Elevation (Z_{water}):

Pick one point near max expected water surface and the other at the mid depth.

$$Z_1 \text{ (ft)} = 3 \quad S_1 \text{ (cf)} = 282,996$$

$$Z_2 \text{ (ft)} = 6 \quad S_2 \text{ (cf)} = 600,920$$

$$b = \ln(S_2/S_1) / \ln(Z_2/Z_1) = 1.1$$

$$K_S = S_2 / Z_2^b = 85,791$$

Ref 2, III-8

Project: Charah Colon Mine	Computed: PAW	Date: 3/5/15
Subject: Permit Application	Checked: MDP	Date: 3/6/15
Task: Sediment Basin #9	Sheet: 3	Of: 4

Determine Settling Velocity

Conversion Factor =	3.281 ft/sec per m/sec	
Gravitational Acceleration, g (m/s^2) =	9.81	
Specific Gravity of soil (s_s) =	2.6	
Kinematic Viscosity of water (ν) =	1.14E-06 $m^2 / sec @ 20^\circ C$	Ref 2, IV-11
Diameter of the Design Particle d_{15} =	40.00E-06 m	
Design Particle Settling Velocity =	$(g / 18) * [(s_s - 1) / \nu] d^2 =$	4.02E-03 ft/sec

Route the Storm through the Basin using the Hydrograph Model

Set Height of Emergency Spillway at (ft) = 7.50 *See Hydrograph*
 Set Top of Dam at (ft) = 8.50

Emergency Spillway

Q_E (cfs) = 100-Yr Storm	
Q_E (cfs) = 55.2	
Cross Section = Trapezoid	
Channel Side Slope (z) =	5 (enter X for X:1)
n =	0.03 Grass Lined
V_p (ft/sec) =	5.0 Permissible Velocity for lining
Allowable Shear Stress (psf) =	2.0 Allowable Shear Stress for lining
Bottom Width, b (ft) =	50

Ref 2, II-7

Calculate Required Depth of Spillway:

Normal-Depth Procedure

$AR^{2/3} = Qn / 1.49s^{0.5}$	$Q = VA$
$Z_{req} = Qn / 1.49s^{0.5}$	Area (A) = $bd + z(d^2)$
$Z_{av} = AR^{2/3}$	$R = Area / (b + 2d((z^2 + 1)^{.5}))$
	Avg Shear Stress (T) = $K_b * d * s * \text{unit weight of water}$

Channel Slope ft/ft	Depth, d (ft)	A (sf)	Z_{req}	R	Z_{avail}	V (ft/sec)	T (psf)
0.01	0.40	20.94	11.12	0.39	11.12	2.6	0.3
0.02	0.33	16.91	7.86	0.32	7.86	3.3	0.4

Construct the channel to be :
 50 ft, Bottom Width (measured at top of lining)
 1.0 ft, depth (measured at top of lining)
 1% slope

Anti-Seep Collar:

Anti-Seep Collar Size = 2 * Barrel Dia
 Anti-Seep Collar Size (ft) = 7
 Use Anti-Seep Collar Size (ft) = 7 x 7

Project: Charah Colon Mine	Computed: PAW	Date: 3/5/15
Subject: Permit Application	Checked: MDP	Date: 3/6/15
Task: Sediment Basin #9	Sheet: 4	Of: 4

Minimum Concrete Base for Riser:

Diameter of Riser (in) = 72 From Hydrograph
 Avg Density of Concrete (lbs/cf) = 87.6
 Density of Water (lbs/cf) = 62.4
 Riser Displacement (cf) = 189.44 $\text{Pi} * (D_R/24)^2 * \text{Total Ht of Riser}$
 Convert cf to cy = 27^{-1}
 Min Concrete Needed (cy) = 5.00
 Width & Length (ft) = 7
 Thickness (ft) = 2.8

Anti-Vortex Device:

Diameter of Riser (in) = 72 From Hydrograph
 Cylinder Diameter (in) = 102 Ref 4, III-104, Table 3.14-D
 Cylinder Thickness (gage) = 14
 Cylinder Height (in) = 36

Determine Tailwater conditions to size outlet apron

Use Normal Depth Procedure (Manning's Eqn.) Ref 2, II-7

$A * R^{2/3} = Q * n / 1.49 s^{0.5}$ Area (A) = $bd + z(d^2)$ $Z_{av} = A * R^{2/3}$
 $Z_{req} = Q * n / 1.49 s^{0.5}$ $R = \text{Area} / (b + 2d((z^2 + 1)^{0.5}))$

n = 0.069 6-inch diameter Rip Rap, Lined Channel
 Vp (ft/sec) = 9 Permissible Velocity for lining
 Side Slope (z) = 5 enter X for X:1
 s (ft/ft) = 0.02 Outlet Slope (estimated)
 Bottom Width (ft) = 10.5 6 * Barrel Diameter
 Q_B (cfs) = 85.1 Peak Flow out of the barrel 25-yr Hydrograph

Q (cfs)	Z _{req}	Flow Depth d (ft)	A (sf)	R (ft)	Z _{av}	V (ft/sec)
85.1	27.88	1.50	27.0	1.05	27.88	3.1

Flow Depth = Tailwater, d (ft) = 1.50 0.5 * Barrel Diameter (ft) = 1.75 Ref 1, 8.06.3

Minimum Tailwater Conditions: $d < 0.5 * \text{Diameter of Outlet Pipe}$

Maximum Tailwater Conditions: $d > 0.5 * \text{Diameter of Outlet Pipe}$

Since the Tailwater is less than half of the diameter of the outlet, use Minimum Tailwater conditions.

Barrel Diameter (ft)	Entrance (ft)	Length (ft)	Outlet Width (ft)	Median Rip Rap Size d ₅₀	Selected Rip Rap Size (in)
3.5	10.5	22	26	0.7	Class B

Conclusion

The basin can contain the 25-yr storm and pass the 100-yr storm without overtopping the berm.

HDR Computation

Project:	Charah Colon Mine	Computed:	PAW	Date:	3/5/15
Subject:	Permit Application	Checked:	MDP	Date:	3/6/15
Task:	Riser Pipe Perforations/Skimmer Flow	Sheet	1	Of	2

Diameter of Riser (in) = 72
 Circumference of Riser (in) = 226.2
 Height of Riser from bottom of barrel (in) = 80 From Hydrograph
 Vertical spacing between holes (in) = 0 center to center
 Water Stage increment (ft) 0.05

Orifice Equation

$Q = C_d * A * (2 * g * h)^{0.5}$ Ref 1, p III-11
 Q = cfs, discharge
 $C_d = 0.6$ coefficient of discharge
 A = sf, cross sectional area
 $g = 32.2$ ft/sec², gravity
 h = ft, driving head measured from the center of the pipe

Row	Perforations					Skimmer	# of skimmers
	1	2	3	4	5	2	
Holes per row	0	0	0	0	0		
Hole Diameter (in)	0.75	0.75	0.75	0.75	0.75		
Spacing edge to edge (in)							
Inlet Area (sf)	0.000	0.000	0.000	0.000	0.000		
Hole Stage (in)	0.50	0.50	0.50	0.50	0.50		
Hole Stage (ft)	0.04	0.04	0.04	0.04	0.04		

Water Stage (ft)	Flow (cfs)	Flow (cfs)	Flow (cfs)	Flow (cfs)	Flow (cfs)	Flow (cfs)	Total Flow (cfs)
0.00	0.00	0.00	0.00			0.00	0.00
0.04	0.00	0.00	0.00			0.00	0.00
0.09	0.00	0.00	0.00			0.00	0.00
0.14	0.00	0.00	0.00			0.00	0.00
0.19	0.00	0.00	0.00			0.00	0.00
0.24	0.00	0.00	0.00			0.00	0.00
0.29	0.00	0.00	0.00			0.00	0.00
0.34	0.00	0.00	0.00			0.66	0.66
0.39	0.00	0.00	0.00			0.66	0.66
0.44	0.00	0.00	0.00			0.66	0.66
0.49	0.00	0.00	0.00			0.66	0.66
0.54	0.00	0.00	0.00			0.66	0.66
0.59	0.00	0.00	0.00			0.66	0.66
0.64	0.00	0.00	0.00			0.66	0.66
0.69	0.00	0.00	0.00			0.66	0.66
0.74	0.00	0.00	0.00			0.66	0.66
0.79	0.00	0.00	0.00			0.66	0.66
0.84	0.00	0.00	0.00			0.66	0.66
0.89	0.00	0.00	0.00			0.66	0.66
0.94	0.00	0.00	0.00			0.66	0.66
0.99	0.00	0.00	0.00			0.66	0.66
1.04	0.00	0.00	0.00			0.66	0.66
1.09	0.00	0.00	0.00			0.66	0.66
1.14	0.00	0.00	0.00			0.66	0.66
1.19	0.00	0.00	0.00			0.66	0.66
1.24	0.00	0.00	0.00			0.66	0.66
1.29	0.00	0.00	0.00			0.66	0.66
1.34	0.00	0.00	0.00			0.66	0.66
1.39	0.00	0.00	0.00			0.66	0.66
1.44	0.00	0.00	0.00			0.66	0.66
1.49	0.00	0.00	0.00			0.66	0.66
1.54	0.00	0.00	0.00			0.66	0.66
1.59	0.00	0.00	0.00			0.66	0.66

HDR Computation

Project:	Charah Colon Mine	Computed: PAW	Date: 3/5/15
Subject:	Permit Application	Checked: MDP	Date: 3/6/15
Task:	Riser Pipe Perforations/Skimmer Flow	Sheet 2	Of 2

1.64	0.00	0.00	0.00	0.66	0.66
1.69	0.00	0.00	0.00	0.66	0.66
1.74	0.00	0.00	0.00	0.66	0.66
1.79	0.00	0.00	0.00	0.66	0.66
1.84	0.00	0.00	0.00	0.66	0.66
1.89	0.00	0.00	0.00	0.66	0.66
1.94	0.00	0.00	0.00	0.66	0.66
1.99	0.00	0.00	0.00	0.66	0.66
2.04	0.00	0.00	0.00	0.66	0.66
2.09	0.00	0.00	0.00	0.66	0.66
2.14	0.00	0.00	0.00	0.66	0.66
2.19	0.00	0.00	0.00	0.66	0.66
2.24	0.00	0.00	0.00	0.66	0.66
2.29	0.00	0.00	0.00	0.66	0.66
2.34	0.00	0.00	0.00	0.66	0.66
2.39	0.00	0.00	0.00	0.66	0.66
2.44	0.00	0.00	0.00	0.66	0.66
2.49	0.00	0.00	0.00	0.66	0.66
2.54	0.00	0.00	0.00	0.66	0.66
2.59	0.00	0.00	0.00	0.66	0.66
2.64	0.00	0.00	0.00	0.66	0.66
2.69	0.00	0.00	0.00	0.66	0.66
2.74	0.00	0.00	0.00	0.66	0.66
2.79	0.00	0.00	0.00	0.66	0.66
2.84	0.00	0.00	0.00	0.66	0.66
2.89	0.00	0.00	0.00	0.66	0.66
2.94	0.00	0.00	0.00	0.66	0.66
2.99	0.00	0.00	0.00	0.66	0.66
3.04	0.00	0.00	0.00	0.66	0.66
3.09	0.00	0.00	0.00	0.66	0.66
3.14	0.00	0.00	0.00	0.66	0.66
3.19	0.00	0.00	0.00	0.66	0.66
3.24	0.00	0.00	0.00	0.66	0.66
3.29	0.00	0.00	0.00	0.66	0.66
3.34	0.00	0.00	0.00	0.66	0.66
3.39	0.00	0.00	0.00	0.66	0.66
3.44	0.00	0.00	0.00	0.66	0.66
3.49	0.00	0.00	0.00	0.66	0.66
3.54	0.00	0.00	0.00	0.66	0.66
3.59	0.00	0.00	0.00	0.66	0.66
3.64	0.00	0.00	0.00	0.66	0.66
3.69	0.00	0.00	0.00	0.66	0.66
3.74	0.00	0.00	0.00	0.66	0.66
3.79	0.00	0.00	0.00	0.66	0.66
3.84	0.00	0.00	0.00	0.66	0.66
3.89	0.00	0.00	0.00	0.66	0.66
3.94	0.00	0.00	0.00	0.66	0.66
3.99	0.00	0.00	0.00	0.66	0.66

Sediment Basin # 9 Colon

Qp = 145.70 cfs
 Tp = 45.32 minutes
 dT = Max of 2 minutes
 or 1.0% of increment to peak

Phase 1
 10 - year Storm Event

b = 1.1
 K_s = 85,791

Number of Riser/Barrel Assemblies = 2
 Diameter of Barrel = 42 (in)
 Height of Riser above barrel = 3.2 (ft)
 Height of Riser from bottom of barrel = 6.7 (ft) elevation 268.70
 Emergency Spillway = 7.5 (ft) elevation 269.50
 Total Height of Dam = 8.5 (ft) elevation 270.50
 Length of Emergency Spillway = 50 (ft)
 Diameter of Riser = 72 (in)
 Permanent Pond Stage = 0 (ft) elevation 262.0

4.0E-03 Settling Velocity of design particle (fps)
 2 Effective number of cells (2 is construction site #)
 100% Minimum Settling Efficiency
 5.4 ft Maximum Stage 267.39 msl elevation
 1.3 cfs Peak outflow
 1.3 cfs Peak Riser/Barrel outflow
 0.0 cfs Peak Weir flow

Notes:

1. Length of emergency spillway is the bottom width of the emergency spillway.
2. Settling efficiency neglects permanent pond volume

TIME	INFLOW	STORAGE	STAGE	Skimmer	RISER	WEIR	BARREL	TOTAL	Bound	Estimated	Settling
(min)	[cfs]	[cu ft]	[ft]	Flow [cfs]	CAPACIT	FLOW	CAPACITY	OUTFLOW	Discharge	Surface	Efficiency
					Y [cfs]	[cfs]	[cfs]	[cfs]	[cfs]	Area (sf)	[%]
0	0.0	0	0.0	0.00	0.00	0.00	0.00	0.00	0.00	-	N/A
2	0.7	0	0.0	0.00	0.00	0.00	0.00	0.00	0.00	-	N/A
4	2.8	84	0.0	0.00	0.00	0.00	0.00	0.00	118.17	53,715	N/A
6	6.2	418	0.0	0.00	0.00	0.00	0.00	0.00	134.27	61,030	N/A
8	10.9	1,163	0.0	0.00	0.00	0.00	0.00	0.00	145.65	66,206	N/A
10	16.8	2,473	0.0	0.00	0.00	0.00	0.00	0.00	154.66	70,300	N/A
12	23.8	4,491	0.1	0.00	0.00	0.00	0.00	0.00	162.17	73,715	N/A
14	31.7	7,345	0.1	0.00	0.00	0.00	0.00	0.00	168.64	76,656	N/A
16	40.4	11,149	0.2	0.00	0.00	0.00	0.00	0.00	174.33	79,242	N/A
18	49.7	15,998	0.2	0.00	0.00	0.00	0.00	0.00	179.41	81,550	N/A
20	59.5	21,965	0.3	0.00	0.00	0.00	0.00	0.00	183.99	83,632	N/A
22	69.5	29,104	0.4	0.66	0.66	0.00	0.66	1.31	188.16	85,525	100%
24	79.6	37,290	0.5	0.66	0.66	0.00	0.66	1.31	191.90	87,227	100%
26	89.6	46,686	0.6	0.66	0.66	0.00	0.66	1.31	195.36	88,800	100%
28	99.2	57,277	0.7	0.66	0.66	0.00	0.66	1.31	198.56	90,256	100%
30	108.3	69,025	0.8	0.66	0.66	0.00	0.66	1.31	201.53	91,605	100%
32	116.8	81,869	1.0	0.66	0.66	0.00	0.66	1.31	204.28	92,856	100%
34	124.4	95,727	1.1	0.66	0.66	0.00	0.66	1.31	206.84	94,018	100%
36	131.0	110,498	1.3	0.66	0.66	0.00	0.66	1.31	209.21	95,097	100%
38	136.5	126,064	1.4	0.66	0.66	0.00	0.66	1.31	211.42	96,099	100%
40	140.8	142,289	1.6	0.66	0.66	0.00	0.66	1.31	213.46	97,029	100%
42	143.8	159,029	1.8	0.66	0.66	0.00	0.66	1.31	215.36	97,891	100%
44	145.4	176,125	1.9	0.66	0.66	0.00	0.66	1.31	217.12	98,689	100%
46	145.6	193,415	2.1	0.66	0.66	0.00	0.66	1.31	218.74	99,426	100%
48	144.4	210,732	2.3	0.66	0.66	0.00	0.66	1.31	220.23	100,107	100%
50	141.9	227,909	2.5	0.66	0.66	0.00	0.66	1.31	221.61	100,732	100%
52	138.0	244,779	2.6	0.66	0.66	0.00	0.66	1.31	222.87	101,306	100%
54	132.9	261,185	2.8	0.66	0.66	0.00	0.66	1.31	224.03	101,830	100%
56	126.6	276,976	2.9	0.66	0.66	0.00	0.66	1.31	225.07	102,306	100%
58	119.8	292,013	3.1	0.66	0.66	0.00	0.66	1.31	226.02	102,737	100%
60	113.1	306,229	3.2	0.66	0.66	0.00	0.66	1.31	226.88	103,126	100%
62	106.8	319,644	3.4	0.66	0.66	0.00	0.66	1.31	227.65	103,479	100%
64	100.8	332,302	3.5	0.66	0.66	0.00	0.66	1.31	228.36	103,799	100%
66	95.2	344,246	3.6	0.66	0.66	0.00	0.66	1.31	229.00	104,091	100%
68	89.9	355,514	3.7	0.66	0.66	0.00	0.66	1.31	229.59	104,357	100%
70	84.9	366,146	3.8	0.66	0.66	0.00	0.66	1.31	230.13	104,602	100%
72	80.2	376,176	3.9	0.66	0.66	0.00	0.66	1.31	230.62	104,827	100%
74	75.7	385,638	4.0	0.66	0.66	0.00	0.66	1.31	231.08	105,035	100%
76	71.5	394,564	4.1	0.66	0.66	0.00	0.66	1.31	231.50	105,226	100%
78	67.5	402,984	4.2	0.66	0.66	0.00	0.66	1.31	231.89	105,403	100%
80	63.7	410,925	4.2	0.66	0.66	0.00	0.66	1.31	232.25	105,566	100%
82	60.2	418,414	4.3	0.66	0.66	0.00	0.66	1.31	232.58	105,718	100%

84	56.8	425,478	4.4	0.66	0.66	0.00	0.66	1.31	232.89	105,859	100%
86	53.6	432,138	4.4	0.66	0.66	0.00	0.66	1.31	233.18	105,990	100%
88	50.7	438,419	4.5	0.66	0.66	0.00	0.66	1.31	233.45	106,112	100%
90	47.8	444,340	4.5	0.66	0.66	0.00	0.66	1.31	233.69	106,225	100%
92	45.2	449,923	4.6	0.66	0.66	0.00	0.66	1.31	233.93	106,330	100%
94	42.6	455,185	4.6	0.66	0.66	0.00	0.66	1.31	234.14	106,429	100%
96	40.3	460,146	4.7	0.66	0.66	0.00	0.66	1.31	234.34	106,520	100%
98	38.0	464,821	4.7	0.66	0.66	0.00	0.66	1.31	234.53	106,606	100%
100	35.9	469,226	4.8	0.66	0.66	0.00	0.66	1.31	234.71	106,686	100%
102	33.9	473,378	4.8	0.66	0.66	0.00	0.66	1.31	234.87	106,761	100%
104	32.0	477,289	4.9	0.66	0.66	0.00	0.66	1.31	235.03	106,831	100%
106	30.2	480,973	4.9	0.66	0.66	0.00	0.66	1.31	235.17	106,896	100%
108	28.5	484,443	4.9	0.66	0.66	0.00	0.66	1.31	235.31	106,957	100%
110	26.9	487,710	5.0	0.66	0.66	0.00	0.66	1.31	235.43	107,014	100%
112	25.4	490,787	5.0	0.66	0.66	0.00	0.66	1.31	235.55	107,068	100%
114	24.0	493,684	5.0	0.66	0.66	0.00	0.66	1.31	235.66	107,118	100%
116	22.7	496,410	5.0	0.66	0.66	0.00	0.66	1.31	235.76	107,165	100%
118	21.4	498,975	5.1	0.66	0.66	0.00	0.66	1.31	235.86	107,209	100%
120	20.2	501,389	5.1	0.66	0.66	0.00	0.66	1.31	235.95	107,250	100%
122	19.1	503,659	5.1	0.66	0.66	0.00	0.66	1.31	236.03	107,289	100%
124	18.0	505,794	5.1	0.66	0.66	0.00	0.66	1.31	236.11	107,325	100%
126	17.0	507,801	5.1	0.66	0.66	0.00	0.66	1.31	236.19	107,358	100%
128	16.1	509,688	5.2	0.66	0.66	0.00	0.66	1.31	236.26	107,390	100%
130	15.2	511,460	5.2	0.66	0.66	0.00	0.66	1.31	236.32	107,420	100%
132	14.3	513,125	5.2	0.66	0.66	0.00	0.66	1.31	236.38	107,448	100%
134	13.5	514,688	5.2	0.66	0.66	0.00	0.66	1.31	236.44	107,474	100%
136	12.8	516,156	5.2	0.66	0.66	0.00	0.66	1.31	236.50	107,498	100%
138	12.1	517,532	5.2	0.66	0.66	0.00	0.66	1.31	236.55	107,521	100%
140	11.4	518,824	5.2	0.66	0.66	0.00	0.66	1.31	236.59	107,542	100%
142	10.8	520,034	5.3	0.66	0.66	0.00	0.66	1.31	236.64	107,562	100%
144	10.2	521,168	5.3	0.66	0.66	0.00	0.66	1.31	236.68	107,580	100%
146	9.6	522,231	5.3	0.66	0.66	0.00	0.66	1.31	236.72	107,598	100%
148	9.1	523,225	5.3	0.66	0.66	0.00	0.66	1.31	236.75	107,614	100%
150	8.6	524,155	5.3	0.66	0.66	0.00	0.66	1.31	236.78	107,629	100%
152	8.1	525,024	5.3	0.66	0.66	0.00	0.66	1.31	236.82	107,644	100%
154	7.6	525,836	5.3	0.66	0.66	0.00	0.66	1.31	236.84	107,657	100%
156	7.2	526,595	5.3	0.66	0.66	0.00	0.66	1.31	236.87	107,669	100%
158	6.8	527,302	5.3	0.66	0.66	0.00	0.66	1.31	236.90	107,681	100%
160	6.4	527,960	5.3	0.66	0.66	0.00	0.66	1.31	236.92	107,691	100%
162	6.1	528,574	5.3	0.66	0.66	0.00	0.66	1.31	236.94	107,701	100%
164	5.7	529,144	5.3	0.66	0.66	0.00	0.66	1.31	236.96	107,711	100%
166	5.4	529,674	5.3	0.66	0.66	0.00	0.66	1.31	236.98	107,719	100%
168	5.1	530,166	5.3	0.66	0.66	0.00	0.66	1.31	237.00	107,727	100%
170	4.8	530,621	5.4	0.66	0.66	0.00	0.66	1.31	237.02	107,734	100%
172	4.6	531,042	5.4	0.66	0.66	0.00	0.66	1.31	237.03	107,741	100%
174	4.3	531,431	5.4	0.66	0.66	0.00	0.66	1.31	237.04	107,747	100%
176	4.1	531,790	5.4	0.66	0.66	0.00	0.66	1.31	237.06	107,753	100%
178	3.8	532,119	5.4	0.66	0.66	0.00	0.66	1.31	237.07	107,759	100%
180	3.6	532,422	5.4	0.66	0.66	0.00	0.66	1.31	237.08	107,763	100%
182	3.4	532,699	5.4	0.66	0.66	0.00	0.66	1.31	237.09	107,768	100%
184	3.2	532,952	5.4	0.66	0.66	0.00	0.66	1.31	237.10	107,772	100%
186	3.0	533,182	5.4	0.66	0.66	0.00	0.66	1.31	237.11	107,776	100%
188	2.9	533,390	5.4	0.66	0.66	0.00	0.66	1.31	237.11	107,779	100%
190	2.7	533,578	5.4	0.66	0.66	0.00	0.66	1.31	237.12	107,782	100%
192	2.6	533,747	5.4	0.66	0.66	0.00	0.66	1.31	237.13	107,785	100%
194	2.4	533,897	5.4	0.66	0.66	0.00	0.66	1.31	237.13	107,787	100%
196	2.3	534,030	5.4	0.66	0.66	0.00	0.66	1.31	237.14	107,789	100%
198	2.2	534,148	5.4	0.66	0.66	0.00	0.66	1.31	237.14	107,791	100%
200	2.0	534,249	5.4	0.66	0.66	0.00	0.66	1.31	237.14	107,793	100%
202	1.9	534,337	5.4	0.66	0.66	0.00	0.66	1.31	237.15	107,794	100%
204	1.8	534,411	5.4	0.66	0.66	0.00	0.66	1.31	237.15	107,795	100%
206	1.7	534,471	5.4	0.66	0.66	0.00	0.66	1.31	237.15	107,796	100%

**Sediment Basin #9 Colon Mine Phase 1 Hydrograph
10-Yr Storm**

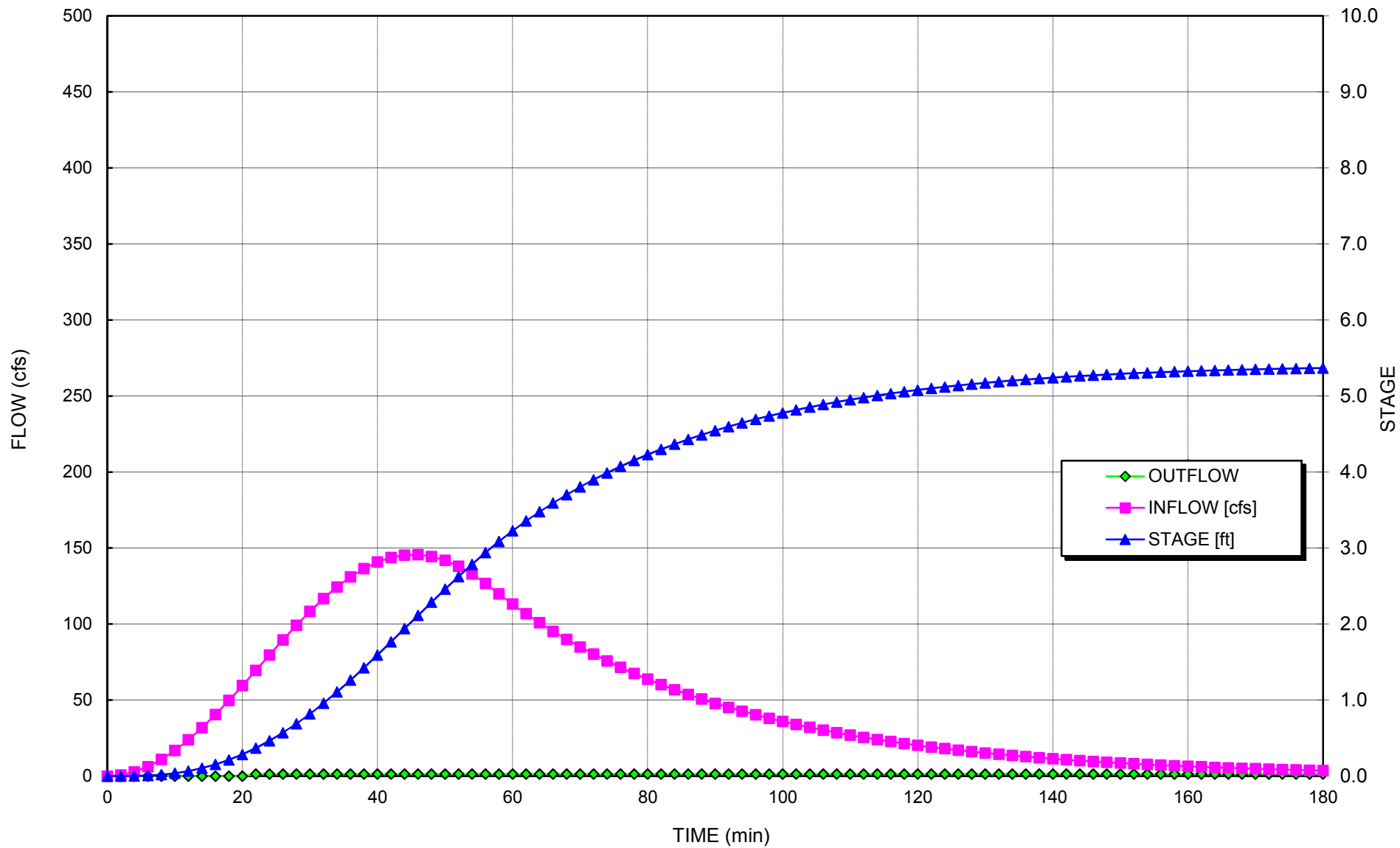

This page intentionally left blank.

Qp = 199.50 cfs
 Tp = 45.27 minutes
 dT = Max of 2 minutes
 or 1.0% of increment to peak

Sediment Basin # 9 Colon
 Phase 2
10 - year Storm Event

Number of Riser/Barrel Assemblies = 2
 Diameter of Barrel = 42 (in)
 Height of Riser above barrel = 3.2 (ft)
 Height of Riser from bottom of barrel = 6.7 (ft) elevation 268.70
 Emergency Spillway = 7.5 (ft) elevation 269.50
 Total Height of Dam = 8.5 (ft) elevation 270.50
 Length of Emergency Spillway = 50 (ft)
 Diameter of Riser = 72 (in)
 Permanent Pond Stage = 0 (ft) elevation 262.0

b = 1.1
 Ks = 85,791

4.0E-03 Settling Velocity of design particle (fps)
 2 Effective number of cells (2 is construction site #)

100% Minimum Settling Efficiency	
6.9 ft Maximum Stage	268.92 msl elevation
14.3 cfs Peak outflow	
14.3 cfs Peak Riser/Barrel outflow	
0.0 cfs peak weir flow	

Notes:

1. Length of emergency spillway is the bottom width of the emergency spillway.
2. Settling efficiency neglects permanent pond volume

TIME (min)	INFLOW [cfs]	STORAGE [cu ft]	STAGE [ft]	Skimmer Flow [cfs]	RISER CAPACIT Y [cfs]	WEIR FLOW [cfs]	BARREL CAPACIT Y [cfs]	TOTAL OUTFLOW [cfs]	Bound Discharge [cfs]	Estimated Surface Area (sf)	Settling Efficiency [%]
0	0.0	0	0.0	0.00	0.00	0.00	0.00	0.00	0.00	-	N/A
2	1.0	0	0.0	0.00	0.00	0.00	0.00	0.00	0.00	-	N/A
4	3.8	115	0.0	0.00	0.00	0.00	0.00	0.00	121.18	55,083	N/A
6	8.5	573	0.0	0.00	0.00	0.00	0.00	0.00	137.69	62,584	N/A
8	15.0	1,596	0.0	0.00	0.00	0.00	0.00	0.00	149.36	67,893	N/A
10	23.1	3,394	0.1	0.00	0.00	0.00	0.00	0.00	158.60	72,091	N/A
12	32.6	6,162	0.1	0.00	0.00	0.00	0.00	0.00	166.30	75,592	N/A
14	43.5	10,078	0.1	0.00	0.00	0.00	0.00	0.00	172.94	78,608	N/A
16	55.4	15,296	0.2	0.00	0.00	0.00	0.00	0.00	178.77	81,260	N/A
18	68.2	21,947	0.3	0.00	0.00	0.00	0.00	0.00	183.98	83,627	N/A
20	81.6	30,132	0.4	0.66	0.66	0.00	0.66	1.31	188.68	85,761	100%
22	95.4	39,768	0.5	0.66	0.66	0.00	0.66	1.31	192.88	87,675	100%
24	109.2	51,053	0.6	0.66	0.66	0.00	0.66	1.31	196.75	89,434	100%
26	122.8	63,997	0.8	0.66	0.66	0.00	0.66	1.31	200.32	91,055	100%
28	136.0	78,579	0.9	0.66	0.66	0.00	0.66	1.31	203.62	92,554	100%
30	148.5	94,745	1.1	0.66	0.66	0.00	0.66	1.31	206.67	93,941	100%
32	160.1	112,413	1.3	0.66	0.66	0.00	0.66	1.31	209.50	95,227	100%
34	170.5	131,468	1.5	0.66	0.66	0.00	0.66	1.31	212.12	96,420	100%
36	179.6	151,772	1.7	0.66	0.66	0.00	0.66	1.31	214.56	97,528	100%
38	187.1	173,161	1.9	0.66	0.66	0.00	0.66	1.31	216.82	98,556	100%
40	192.9	195,452	2.1	0.66	0.66	0.00	0.66	1.31	218.92	99,509	100%
42	196.9	218,443	2.4	0.66	0.66	0.00	0.66	1.31	220.86	100,393	100%
44	199.1	241,919	2.6	0.66	0.66	0.00	0.66	1.31	222.66	101,211	100%
46	199.4	265,655	2.8	0.66	0.66	0.00	0.66	1.31	224.33	101,967	100%
48	197.7	289,422	3.1	0.66	0.66	0.00	0.66	1.31	225.86	102,665	100%
50	194.2	312,991	3.3	0.66	0.66	0.00	0.66	1.31	227.27	103,306	100%
52	188.8	336,135	3.5	0.66	0.66	0.00	0.66	1.31	228.57	103,893	100%
54	181.8	358,637	3.7	0.66	0.66	0.00	0.66	1.31	229.75	104,430	100%
56	173.1	380,290	3.9	0.66	0.66	0.00	0.66	1.31	230.82	104,918	100%
58	163.7	400,906	4.1	0.66	0.66	0.00	0.66	1.31	231.79	105,359	100%
60	154.6	420,396	4.3	0.66	0.66	0.00	0.66	1.31	232.67	105,758	100%
62	146.0	438,789	4.5	0.66	0.66	0.00	0.66	1.31	233.46	106,119	100%
64	137.8	456,147	4.7	0.66	0.66	0.00	0.66	1.31	234.18	106,447	100%
66	130.1	472,527	4.8	0.66	0.66	0.00	0.66	1.31	234.84	106,746	100%
68	122.9	487,984	5.0	0.66	0.66	0.00	0.66	1.31	235.44	107,019	100%
70	116.0	502,570	5.1	0.66	0.66	0.00	0.66	1.31	235.99	107,270	100%
72	109.5	516,332	5.2	0.66	0.66	0.00	0.66	1.31	236.50	107,501	100%
74	103.4	529,318	5.3	0.66	0.66	0.00	0.66	1.31	236.97	107,713	100%
76	97.6	541,571	5.5	0.66	0.66	0.00	0.66	1.31	237.40	107,910	100%
78	92.2	553,131	5.6	0.66	0.66	0.00	0.66	1.31	237.80	108,091	100%
80	87.0	564,036	5.7	0.66	0.66	0.00	0.66	1.31	238.17	108,259	100%
82	82.2	574,325	5.8	0.66	0.66	0.00	0.66	1.31	238.51	108,415	100%
84	77.6	584,030	5.8	0.66	0.66	0.00	0.66	1.31	238.83	108,559	100%

86	73.3	593,185	5.9	0.66	0.66	0.00	0.66	1.31	239.13	108,693	100%
88	69.2	601,820	6.0	0.66	0.66	0.00	0.66	1.31	239.40	108,818	100%
90	65.3	609,964	6.1	0.66	0.66	0.00	0.66	1.31	239.66	108,935	100%
92	61.7	617,645	6.2	0.66	0.66	0.00	0.66	1.31	239.90	109,043	100%
94	58.2	624,889	6.2	0.66	0.66	0.00	0.66	1.31	240.12	109,144	100%
96	55.0	631,720	6.3	0.66	0.66	0.00	0.66	1.31	240.33	109,239	100%
98	51.9	638,160	6.3	0.66	0.66	0.00	0.66	1.31	240.52	109,327	100%
100	49.0	644,232	6.4	0.66	0.66	0.00	0.66	1.31	240.70	109,409	100%
102	46.3	649,957	6.4	0.66	0.66	0.00	0.66	1.31	240.87	109,486	100%
104	43.7	655,353	6.5	0.66	0.66	0.00	0.66	1.31	241.03	109,558	100%
106	41.3	660,440	6.5	0.66	0.66	0.00	0.66	1.31	241.18	109,626	100%
108	39.0	665,233	6.6	0.66	0.66	0.00	0.66	1.31	241.32	109,689	100%
110	36.8	669,751	6.6	0.66	0.66	0.00	0.66	1.31	241.45	109,748	100%
112	34.7	674,007	6.7	0.66	0.66	0.00	0.66	1.31	241.57	109,803	100%
114	32.8	678,017	6.7	0.66	0.68	0.00	102.96	1.36	241.68	109,855	100%
116	31.0	681,789	6.7	0.66	1.14	0.00	103.31	2.28	241.79	109,903	100%
118	29.2	685,230	6.8	0.66	1.83	0.00	103.64	3.65	241.88	109,947	100%
120	27.6	688,300	6.8	0.66	2.58	0.00	103.92	5.17	241.97	109,987	100%
122	26.1	690,992	6.8	0.66	3.34	0.00	104.18	6.69	242.05	110,021	100%
124	24.6	693,317	6.8	0.66	4.06	0.00	104.39	8.13	242.11	110,050	100%
126	23.2	695,294	6.9	0.66	4.72	0.00	104.58	9.44	242.16	110,075	100%
128	21.9	696,949	6.9	0.66	5.30	0.00	104.73	10.60	242.21	110,096	100%
130	20.7	698,310	6.9	0.66	5.79	0.00	104.86	11.58	242.25	110,113	100%
132	19.6	699,405	6.9	0.66	6.20	0.00	104.96	12.40	242.28	110,127	100%
134	18.5	700,264	6.9	0.66	6.53	0.00	105.04	13.06	242.30	110,137	100%
136	17.4	700,912	6.9	0.66	6.78	0.00	105.10	13.56	242.32	110,145	100%
138	16.5	701,377	6.9	0.66	6.96	0.00	105.14	13.93	242.33	110,151	100%
140	15.5	701,681	6.9	0.66	7.08	0.00	105.17	14.17	242.34	110,155	100%
142	14.7	701,846	6.9	0.66	7.15	0.00	105.18	14.30	242.35	110,157	100%
144	13.9	701,891	6.9	0.66	7.17	0.00	105.19	14.34	242.35	110,158	100%
146	13.1	701,833	6.9	0.66	7.14	0.00	105.18	14.29	242.35	110,157	100%
148	12.4	701,688	6.9	0.66	7.09	0.00	105.17	14.17	242.34	110,155	100%
150	11.7	701,469	6.9	0.66	7.00	0.00	105.15	14.00	242.34	110,152	100%
152	11.0	701,189	6.9	0.66	6.89	0.00	105.12	13.78	242.33	110,149	100%
154	10.4	700,857	6.9	0.66	6.76	0.00	105.09	13.52	242.32	110,145	100%
156	9.8	700,482	6.9	0.66	6.61	0.00	105.06	13.23	242.31	110,140	100%
158	9.3	700,073	6.9	0.66	6.46	0.00	105.02	12.91	242.30	110,135	100%
160	8.8	699,636	6.9	0.66	6.29	0.00	104.98	12.58	242.28	110,129	100%
162	8.3	699,177	6.9	0.66	6.11	0.00	104.94	12.23	242.27	110,124	100%
164	7.8	698,701	6.9	0.66	5.94	0.00	104.89	11.87	242.26	110,118	100%
166	7.4	698,212	6.9	0.66	5.76	0.00	104.85	11.51	242.25	110,112	100%
168	7.0	697,715	6.9	0.66	5.57	0.00	104.80	11.15	242.23	110,105	100%
170	6.6	697,212	6.9	0.66	5.39	0.00	104.76	10.78	242.22	110,099	100%
172	6.2	696,706	6.9	0.66	5.21	0.00	104.71	10.42	242.20	110,093	100%
174	5.9	696,199	6.9	0.66	5.03	0.00	104.66	10.07	242.19	110,086	100%
176	5.5	695,694	6.9	0.66	4.86	0.00	104.61	9.71	242.18	110,080	100%
178	5.2	695,191	6.9	0.66	4.68	0.00	104.57	9.37	242.16	110,074	100%
180	4.9	694,693	6.9	0.66	4.52	0.00	104.52	9.03	242.15	110,067	100%
182	4.7	694,201	6.9	0.66	4.35	0.00	104.48	8.70	242.13	110,061	100%
184	4.4	693,715	6.8	0.66	4.19	0.00	104.43	8.39	242.12	110,055	100%
186	4.1	693,236	6.8	0.66	4.04	0.00	104.39	8.07	242.11	110,049	100%
188	3.9	692,764	6.8	0.66	3.89	0.00	104.34	7.77	242.09	110,043	100%
190	3.7	692,301	6.8	0.66	3.74	0.00	104.30	7.48	242.08	110,037	100%
192	3.5	691,847	6.8	0.66	3.60	0.00	104.26	7.20	242.07	110,031	100%
194	3.3	691,402	6.8	0.66	3.47	0.00	104.21	6.93	242.06	110,026	100%
196	3.1	690,965	6.8	0.66	3.34	0.00	104.17	6.67	242.04	110,020	100%
198	2.9	690,538	6.8	0.66	3.21	0.00	104.13	6.42	242.03	110,015	100%
200	2.8	690,121	6.8	0.66	3.09	0.00	104.10	6.18	242.02	110,010	100%
202	2.6	689,713	6.8	0.66	2.97	0.00	104.06	5.94	242.01	110,004	100%
204	2.5	689,314	6.8	0.66	2.86	0.00	104.02	5.72	242.00	109,999	100%

Sediment Basin #9 Colon Mine Phase 2 Hydrograph 10-Yr Storm

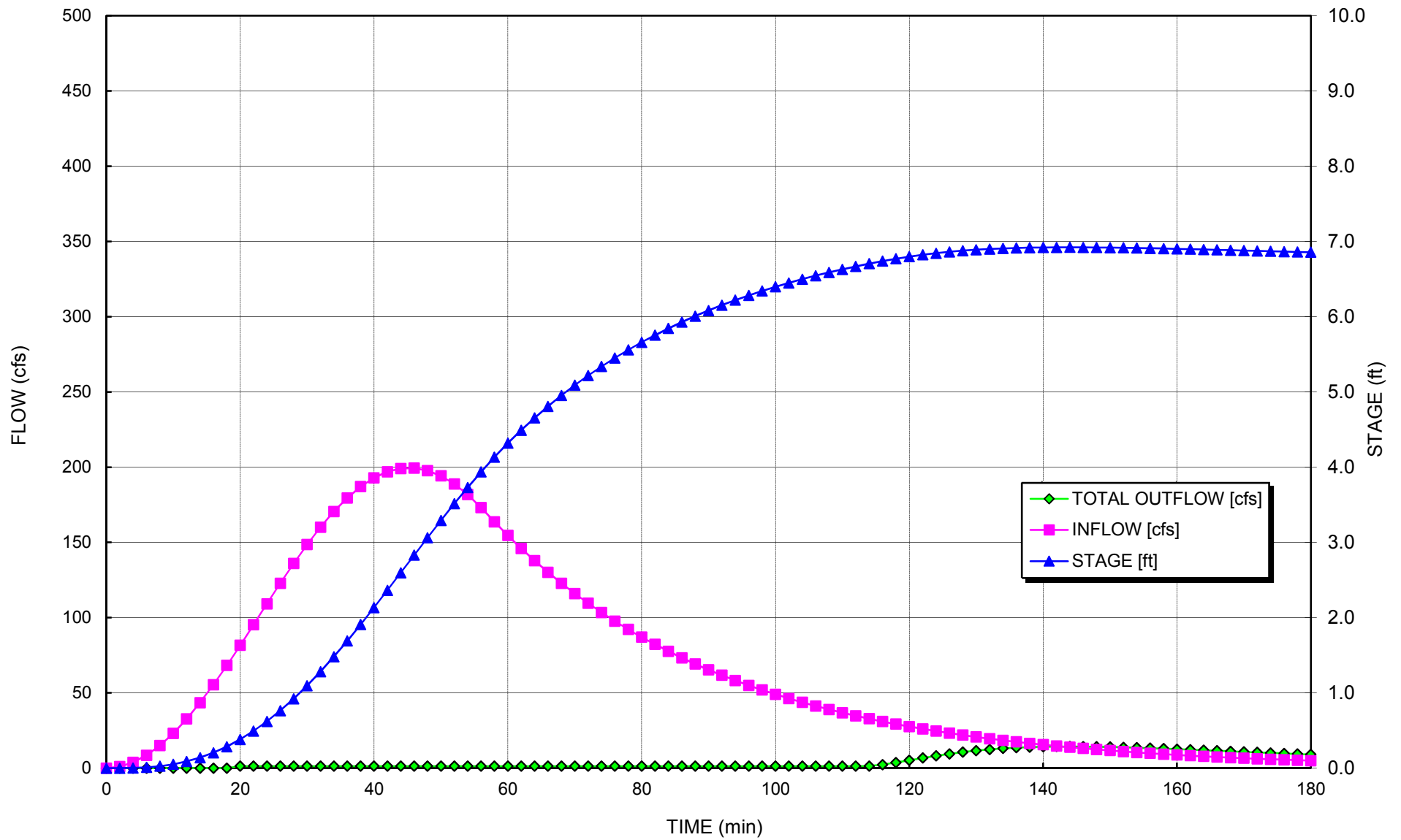

This page intentionally left blank.

Qp = 268.73 cfs
 Tp = 44.85 minutes
 dT = Max of 2 minutes
 or 1.0% of increment to peak

Sediment Basin # 9 Colon
 Phase 2
25 - year Storm Event

Number of Riser/Barrel Assemblies = 2
 Diameter of Barrel = 42 (in)
 Height of Riser above barrel = 3.2 (ft)
 Height of Riser from bottom of barrel = 6.7 (ft) elevatior 268.70
 Emergency Spillway = 7.5 (ft) elevatior 269.50
 Total Height of Dam = 8.5 (ft) elevatior 270.50
 Length of Emergency Spillway = 50 (ft)
 Diameter of Riser = 72 (in)
 Permanent Pond Stage = 0 (ft) elevatior 262.0

b = 1.1
 Ks = 85,791

4.0E-03 Settling Velocity of design particle (fps)
 2 Effective number of cells (2 is construction site #)

92% Minimum Settling Efficiency	
7.5 ft Maximum Stage	269.5 msl elevation
85.1 cfs Peak outflow	
85.1 cfs Peak Riser/Barrel outflow	
0.0 cfs peak weir flow	

Notes:

1. Length of emergency spillway is the bottom width of the emergency spillway.
2. Settling efficiency neglects permanent pond volume

TIME (min)	INFLOW [cfs]	STORAGE [cu ft]	STAGE [ft]	Skimmer Flow [cfs]	RISER CAPACIT Y [cfs]	WEIR FLOW [cfs]	BARREL CAPACITY [cfs]	TOTAL OUTFL OW [cfs]	Bound Discharge [cfs]	Estimated Surface Area (sf)	Settling Efficiency [%]
0	0.0	0	0.0	0.00	0.00	0.00	0.00	0.00	0.00	-	N/A
2	1.3	0	0.0	0.00	0.00	0.00	0.00	0.00	0.00	-	N/A
4	5.2	158	0.0	0.00	0.00	0.00	0.00	0.00	124.27	56,487	N/A
6	11.7	787	0.0	0.00	0.00	0.00	0.00	0.00	141.19	64,179	N/A
8	20.5	2,190	0.0	0.00	0.00	0.00	0.00	0.00	153.17	69,622	N/A
10	31.6	4,656	0.1	0.00	0.00	0.00	0.00	0.00	162.64	73,926	N/A
12	44.7	8,452	0.1	0.00	0.00	0.00	0.00	0.00	170.54	77,516	N/A
14	59.6	13,820	0.2	0.00	0.00	0.00	0.00	0.00	177.34	80,607	N/A
16	75.9	20,971	0.3	0.00	0.00	0.00	0.00	0.00	183.31	83,325	N/A
18	93.4	30,080	0.4	0.66	0.66	0.00	0.66	1.31	188.65	85,750	100%
20	111.6	41,128	0.5	0.66	0.66	0.00	0.66	1.31	193.40	87,909	100%
22	130.4	54,368	0.7	0.66	0.66	0.00	0.66	1.31	197.74	89,882	100%
24	149.2	69,854	0.8	0.66	0.66	0.00	0.66	1.31	201.72	91,692	100%
26	167.7	87,595	1.0	0.66	0.66	0.00	0.66	1.31	205.38	93,357	100%
28	185.5	107,556	1.2	0.66	0.66	0.00	0.66	1.31	208.77	94,893	100%
30	202.4	129,659	1.5	0.66	0.66	0.00	0.66	1.31	211.89	96,314	100%
32	217.9	153,785	1.7	0.66	0.66	0.00	0.66	1.31	214.79	97,630	100%
34	231.7	179,772	2.0	0.66	0.66	0.00	0.66	1.31	217.47	98,850	100%
36	243.7	207,424	2.3	0.66	0.66	0.00	0.66	1.31	219.96	99,981	100%
38	253.6	236,514	2.5	0.66	0.66	0.00	0.66	1.31	222.27	101,030	100%
40	261.0	266,783	2.8	0.66	0.66	0.00	0.66	1.31	224.40	102,002	100%
42	266.1	297,951	3.1	0.66	0.66	0.00	0.66	1.31	226.38	102,902	100%
44	268.5	329,721	3.5	0.66	0.66	0.00	0.66	1.31	228.22	103,734	100%
46	268.3	361,783	3.8	0.66	0.66	0.00	0.66	1.31	229.91	104,503	100%
48	265.5	393,821	4.1	0.66	0.66	0.00	0.66	1.31	231.46	105,210	100%
50	260.1	425,521	4.4	0.66	0.66	0.00	0.66	1.31	232.89	105,860	100%
52	252.2	456,574	4.7	0.66	0.66	0.00	0.66	1.31	234.20	106,454	100%
54	242.1	486,685	4.9	0.66	0.66	0.00	0.66	1.31	235.39	106,996	100%
56	229.8	515,577	5.2	0.66	0.66	0.00	0.66	1.31	236.47	107,488	100%
58	217.1	542,996	5.5	0.66	0.66	0.00	0.66	1.31	237.45	107,932	100%
60	204.9	568,894	5.7	0.66	0.66	0.00	0.66	1.31	238.33	108,333	100%
62	193.4	593,324	5.9	0.66	0.66	0.00	0.66	1.31	239.13	108,696	100%
64	182.5	616,370	6.1	0.66	0.66	0.00	0.66	1.31	239.86	109,025	100%
66	172.2	638,109	6.3	0.66	0.66	0.00	0.66	1.31	240.52	109,326	100%
68	162.5	658,614	6.5	0.66	0.66	0.00	0.66	1.31	241.12	109,602	100%
70	153.3	677,956	6.7	0.66	0.67	0.00	102.95	1.35	241.68	109,854	100%
72	144.7	696,195	6.9	0.66	5.03	0.00	104.66	10.06	242.19	110,086	100%
74	136.6	712,352	7.0	0.66	11.76	0.00	106.15	23.52	242.63	110,287	99%
76	128.9	725,917	7.1	0.66	18.81	0.00	107.38	37.61	243.00	110,453	98%
78	121.6	736,867	7.2	0.66	25.27	0.00	108.36	50.54	243.29	110,584	97%
80	114.8	745,394	7.3	0.66	30.74	0.00	109.12	61.47	243.51	110,686	95%
82	108.3	751,788	7.4	0.66	35.06	0.00	109.69	70.13	243.67	110,761	94%
84	102.2	756,368	7.4	0.66	38.28	0.00	110.09	76.56	243.79	110,814	93%

86	96.4	759,445	7.4	0.66	40.49	0.00	110.36	80.98	243.87	110,850	93%
88	91.0	761,300	7.5	0.66	41.84	0.00	110.52	83.69	243.92	110,872	93%
90	85.9	762,179	7.5	0.66	42.49	0.00	110.60	84.98	243.94	110,882	92%
92	81.0	762,287	7.5	0.66	42.57	0.00	110.61	85.14	243.94	110,883	92%
94	76.5	761,796	7.5	0.66	42.21	0.00	110.56	84.41	243.93	110,877	92%
96	72.2	760,844	7.5	0.66	41.51	0.00	110.48	83.02	243.91	110,866	93%
98	68.1	759,543	7.4	0.66	40.56	0.00	110.37	81.12	243.87	110,851	93%
100	64.3	757,981	7.4	0.66	39.43	0.00	110.23	78.86	243.83	110,833	93%
102	60.7	756,230	7.4	0.66	38.18	0.00	110.08	76.36	243.79	110,813	93%
104	57.2	754,345	7.4	0.66	36.85	0.00	109.91	73.69	243.74	110,791	94%
106	54.0	752,370	7.4	0.66	35.47	0.00	109.74	70.93	243.69	110,768	94%
108	51.0	750,340	7.4	0.66	34.07	0.00	109.56	68.13	243.64	110,744	94%
110	48.1	748,280	7.3	0.66	32.67	0.00	109.38	65.33	243.58	110,720	95%
112	45.4	746,212	7.3	0.66	31.28	0.00	109.19	62.56	243.53	110,695	95%
114	42.8	744,152	7.3	0.66	29.92	0.00	109.01	59.84	243.48	110,671	95%
116	40.4	742,112	7.3	0.66	28.59	0.00	108.83	57.18	243.42	110,647	96%
118	38.1	740,101	7.3	0.66	27.30	0.00	108.65	54.60	243.37	110,623	96%
120	36.0	738,126	7.3	0.66	26.06	0.00	108.47	52.11	243.32	110,599	96%
122	34.0	736,192	7.2	0.66	24.86	0.00	108.30	49.71	243.27	110,576	97%
124	32.1	734,303	7.2	0.66	23.70	0.00	108.13	47.40	243.22	110,554	97%
126	30.3	732,462	7.2	0.66	22.59	0.00	107.97	45.19	243.17	110,532	97%
128	28.5	730,669	7.2	0.66	21.53	0.00	107.81	43.07	243.12	110,510	97%
130	26.9	728,927	7.2	0.66	20.52	0.00	107.65	41.04	243.08	110,489	98%
132	25.4	727,235	7.2	0.66	19.55	0.00	107.50	39.10	243.03	110,469	98%
134	24.0	725,594	7.1	0.66	18.63	0.00	107.35	37.25	242.99	110,449	98%
136	22.6	724,002	7.1	0.66	17.74	0.00	107.21	35.49	242.95	110,430	98%
138	21.4	722,460	7.1	0.66	16.90	0.00	107.07	33.81	242.90	110,411	98%
140	20.2	720,967	7.1	0.66	16.10	0.00	106.93	32.21	242.86	110,393	98%
142	19.0	719,521	7.1	0.66	15.34	0.00	106.80	30.69	242.83	110,375	99%
144	18.0	718,122	7.1	0.66	14.62	0.00	106.67	29.24	242.79	110,358	99%
146	16.9	716,768	7.1	0.66	13.93	0.00	106.55	27.86	242.75	110,342	99%
148	16.0	715,458	7.0	0.66	13.27	0.00	106.43	26.54	242.72	110,326	99%
150	15.1	714,192	7.0	0.66	12.65	0.00	106.32	25.29	242.68	110,310	99%
152	14.2	712,967	7.0	0.66	12.05	0.00	106.20	24.11	242.65	110,295	99%
154	13.4	711,783	7.0	0.66	11.49	0.00	106.10	22.98	242.62	110,280	99%
156	12.7	710,637	7.0	0.66	10.95	0.00	105.99	21.91	242.59	110,266	99%
158	12.0	709,530	7.0	0.66	10.44	0.00	105.89	20.89	242.56	110,253	99%
160	11.3	708,460	7.0	0.66	9.96	0.00	105.79	19.92	242.53	110,239	99%
162	10.7	707,425	7.0	0.66	9.50	0.00	105.70	18.99	242.50	110,226	99%
164	10.1	706,424	7.0	0.66	9.06	0.00	105.61	18.12	242.47	110,214	99%
166	9.5	705,457	7.0	0.66	8.64	0.00	105.52	17.28	242.44	110,202	99%
168	9.0	704,522	6.9	0.66	8.25	0.00	105.43	16.49	242.42	110,190	100%
170	8.5	703,617	6.9	0.66	7.87	0.00	105.35	15.74	242.39	110,179	100%
172	8.0	702,743	6.9	0.66	7.51	0.00	105.27	15.02	242.37	110,168	100%
174	7.5	701,897	6.9	0.66	7.17	0.00	105.19	14.34	242.35	110,158	100%
176	7.1	701,079	6.9	0.66	6.85	0.00	105.11	13.69	242.32	110,148	100%
178	6.7	700,288	6.9	0.66	6.54	0.00	105.04	13.08	242.30	110,138	100%
180	6.3	699,523	6.9	0.66	6.25	0.00	104.97	12.49	242.28	110,128	100%
182	6.0	698,783	6.9	0.66	5.97	0.00	104.90	11.93	242.26	110,119	100%
184	5.6	698,067	6.9	0.66	5.70	0.00	104.83	11.40	242.24	110,110	100%
186	5.3	697,375	6.9	0.66	5.45	0.00	104.77	10.90	242.22	110,101	100%
188	5.0	696,704	6.9	0.66	5.21	0.00	104.71	10.42	242.20	110,093	100%
190	4.7	696,056	6.9	0.66	4.98	0.00	104.65	9.96	242.19	110,085	100%
192	4.5	695,428	6.9	0.66	4.77	0.00	104.59	9.53	242.17	110,077	100%
194	4.2	694,820	6.9	0.66	4.56	0.00	104.53	9.12	242.15	110,069	100%
196	4.0	694,232	6.9	0.66	4.36	0.00	104.48	8.72	242.14	110,062	100%
198	3.8	693,662	6.8	0.66	4.18	0.00	104.43	8.35	242.12	110,054	100%
200	3.5	693,110	6.8	0.66	4.00	0.00	104.37	7.99	242.10	110,047	100%
202	3.3	692,576	6.8	0.66	3.83	0.00	104.32	7.66	242.09	110,041	100%
204	3.2	692,058	6.8	0.66	3.67	0.00	104.28	7.33	242.08	110,034	100%
206	3.0	691,557	6.8	0.66	3.51	0.00	104.23	7.03	242.06	110,028	100%

Sediment Basin #9 Colon Mine Phase 2 Hydrograph 25-Yr Storm

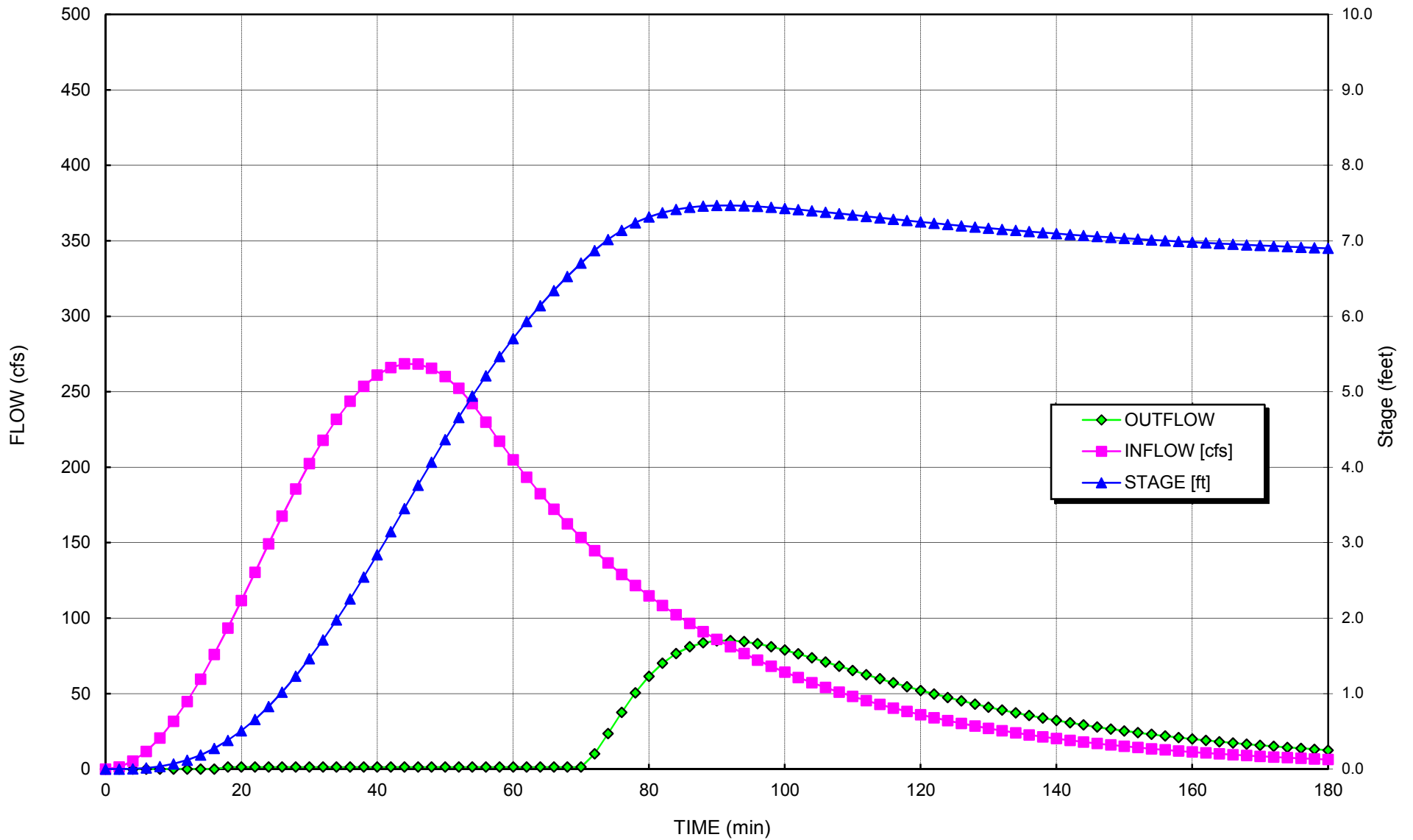

This page intentionally left blank.

Qp = 384.1 cfs
 Tp = 44.7 minutes
 dT = Max of 2 minutes
 or 1.0% of increment to peak

Sediment Basin # 9 **Colon**
 Phase 2
100 - year Storm Event

b = 1.1
 Ks = 85,791

Number of Riser/Barrel Assemblies = 2
 Diameter of Barrel = 42 (in)
 Height of Riser above barrel = 3.2 (ft)
 Height of Riser from bottom of barrel = 6.7 (ft) elevation 268.70
 Emergency Spillway = 7.5 (ft) elevation 269.50
 Total Height of Dam = 8.5 (ft) elevation 270.50
 Length of Emergency Spillway = 50 (ft)
 Diameter of Riser = 72 (in)
 Permanent Pond Stage = 0 (ft) elevation 262.0

4.0E-03 Settling Velocity of design particle (fps)
 2 Effective number of cells (2 is construction site #)

73% Minimum Settling Efficiency	
8.0 ft Maximum Stage	270.0 msl elevation
243.8 cfs Peak outflow	
188.6 cfs Peak Riser/Barrel outflow	
55.2 cfs peak weir flow	

Notes:

1. Length of emergency spillway is the bottom width of the emergency spillway.
2. Settling efficiency neglects permanent pond volume

TIME (min)	INFLOW [cfs]	STORAGE [cu ft]	STAGE [ft]	Skimmer Flow [cfs]	RISER CAPACIT Y [cfs]	WEIR FLOW [cfs]	BARREL CAPACITY [cfs]	TOTAL OUTFLOW [cfs]	Bound Discharge [cfs]	Estimated Surface Area (sf)	Settling Efficiency [%]
0	0.0	0	0.0	0.00	0.00	0.00	0.00	0.00	0.00	-	N/A
2	1.9	0	0.0	0.00	0.00	0.00	0.00	0.00	0.00	-	N/A
4	7.5	228	0.0	0.00	0.00	0.00	0.00	0.00	127.93	58,150	N/A
6	16.8	1,133	0.0	0.00	0.00	0.00	0.00	0.00	145.35	66,068	N/A
8	29.6	3,154	0.0	0.00	0.00	0.00	0.00	0.00	157.68	71,672	N/A
10	45.6	6,705	0.1	0.00	0.00	0.00	0.00	0.00	167.42	76,102	N/A
12	64.4	12,171	0.2	0.00	0.00	0.00	0.00	0.00	175.55	79,797	N/A
14	85.8	19,900	0.3	0.00	0.00	0.00	0.00	0.00	182.55	82,978	N/A
16	109.2	30,193	0.4	0.66	0.66	0.00	0.66	1.31	188.71	85,775	100%
18	134.4	43,145	0.5	0.66	0.66	0.00	0.66	1.31	194.14	88,245	100%
20	160.6	59,110	0.7	0.66	0.66	0.00	0.66	1.31	199.06	90,482	100%
22	187.5	78,225	0.9	0.66	0.66	0.00	0.66	1.31	203.55	92,521	100%
24	214.4	100,563	1.2	0.66	0.66	0.00	0.66	1.31	207.65	94,387	100%
26	240.9	126,135	1.4	0.66	0.66	0.00	0.66	1.31	211.43	96,103	100%
28	266.5	154,890	1.7	0.66	0.66	0.00	0.66	1.31	214.91	97,686	100%
30	290.6	186,710	2.0	0.66	0.66	0.00	0.66	1.31	218.12	99,148	100%
32	312.7	221,419	2.4	0.66	0.66	0.00	0.66	1.31	221.10	100,501	100%
34	332.4	258,784	2.8	0.66	0.66	0.00	0.66	1.31	223.86	101,755	100%
36	349.4	298,519	3.2	0.66	0.66	0.00	0.66	1.31	226.42	102,918	100%
38	363.3	340,291	3.6	0.66	0.66	0.00	0.66	1.31	228.79	103,995	100%
40	373.8	383,728	4.0	0.66	0.66	0.00	0.66	1.31	230.98	104,993	100%
42	380.7	428,423	4.4	0.66	0.66	0.00	0.66	1.31	233.02	105,917	100%
44	383.8	473,946	4.8	0.66	0.66	0.00	0.66	1.31	234.90	106,771	100%
46	383.2	519,850	5.3	0.66	0.66	0.00	0.66	1.31	236.63	107,559	100%
48	378.8	565,680	5.7	0.66	0.66	0.00	0.66	1.31	238.22	108,284	100%
50	370.8	610,984	6.1	0.66	0.66	0.00	0.66	1.31	239.69	108,949	100%
52	359.2	655,318	6.5	0.66	0.66	0.00	0.66	1.31	241.03	109,558	100%
54	344.2	698,260	6.9	0.66	5.77	0.00	104.85	11.55	242.25	110,112	100%
56	326.7	738,184	7.3	0.66	26.09	0.00	108.48	52.19	243.32	110,600	96%
58	308.3	771,132	7.5	0.66	49.26	1.59	111.37	100.11	244.17	110,985	90%
60	290.8	796,112	7.8	0.66	69.80	21.41	113.51	161.02	244.79	111,267	82%
62	274.4	811,692	7.9	0.66	83.76	39.82	114.82	207.33	245.16	111,438	77%
64	258.9	819,740	8.0	0.66	91.29	50.70	115.49	233.27	245.36	111,526	74%
66	244.3	822,814	8.0	0.66	94.22	55.08	115.75	243.52	245.43	111,559	73%
68	230.4	822,903	8.0	0.66	94.30	55.21	115.76	243.81	245.43	111,560	73%
70	217.4	821,299	8.0	0.66	92.77	52.91	115.62	238.44	245.39	111,543	73%
72	205.1	818,776	8.0	0.66	90.37	49.35	115.41	230.10	245.33	111,515	74%
74	193.5	815,779	7.9	0.66	87.56	45.23	115.16	220.35	245.26	111,483	75%
76	182.6	812,561	7.9	0.66	84.56	40.95	114.90	210.07	245.18	111,448	77%
78	172.3	809,263	7.9	0.66	81.53	36.71	114.62	199.76	245.11	111,412	78%
80	162.5	805,963	7.9	0.66	78.53	32.62	114.34	189.68	245.03	111,375	79%
82	153.3	802,705	7.8	0.66	75.61	28.74	114.07	179.95	244.95	111,340	80%
84	144.7	799,511	7.8	0.66	72.78	25.10	113.80	170.65	244.87	111,304	81%

86	136.5	796,393	7.8	0.66	70.05	21.71	113.54	161.80	244.79	111,270	82%
88	128.8	793,356	7.7	0.66	67.42	18.56	113.28	153.41	244.72	111,236	83%
90	121.5	790,399	7.7	0.66	64.90	15.66	113.03	145.46	244.65	111,203	84%
92	114.6	787,523	7.7	0.66	62.48	13.00	112.78	137.95	244.58	111,171	85%
94	108.1	784,724	7.7	0.66	60.14	10.58	112.54	130.87	244.51	111,139	86%
96	102.0	781,997	7.6	0.66	57.90	8.38	112.31	124.19	244.44	111,108	87%
98	96.3	779,338	7.6	0.66	55.74	6.41	112.08	117.90	244.37	111,078	88%
100	90.8	776,741	7.6	0.66	53.66	4.66	111.86	111.99	244.31	111,049	89%
102	85.7	774,201	7.6	0.66	51.65	3.14	111.64	106.45	244.24	111,020	90%
104	80.8	771,710	7.6	0.66	49.71	1.86	111.42	101.27	244.18	110,992	90%
106	76.3	769,259	7.5	0.66	47.81	0.84	111.21	96.46	244.12	110,963	91%
108	72.0	766,835	7.5	0.66	45.97	0.14	111.00	92.08	244.06	110,936	91%
110	67.9	764,421	7.5	0.66	44.15	0.00	110.79	88.31	244.00	110,908	92%
112	64.1	761,972	7.5	0.66	42.34	0.00	110.58	84.67	243.93	110,879	92%
114	60.4	759,497	7.4	0.66	40.53	0.00	110.36	81.05	243.87	110,851	93%
116	57.0	757,022	7.4	0.66	38.74	0.00	110.15	77.49	243.81	110,822	93%
118	53.8	754,565	7.4	0.66	37.00	0.00	109.93	74.00	243.75	110,793	94%
120	50.8	752,140	7.4	0.66	35.31	0.00	109.72	70.61	243.68	110,765	94%
122	47.9	749,756	7.4	0.66	33.67	0.00	109.51	67.34	243.62	110,737	95%
124	45.2	747,422	7.3	0.66	32.09	0.00	109.30	64.18	243.56	110,710	95%
126	42.6	745,142	7.3	0.66	30.57	0.00	109.10	61.14	243.50	110,683	95%
128	40.2	742,919	7.3	0.66	29.11	0.00	108.90	58.23	243.44	110,656	96%
130	37.9	740,757	7.3	0.66	27.72	0.00	108.71	55.44	243.39	110,631	96%
132	35.8	738,657	7.3	0.66	26.39	0.00	108.52	52.78	243.33	110,606	96%
134	33.8	736,619	7.2	0.66	25.12	0.00	108.34	50.24	243.28	110,582	97%
136	31.9	734,643	7.2	0.66	23.91	0.00	108.16	47.81	243.23	110,558	97%
138	30.1	732,728	7.2	0.66	22.75	0.00	107.99	45.51	243.18	110,535	97%
140	28.4	730,875	7.2	0.66	21.65	0.00	107.83	43.31	243.13	110,513	97%
142	26.8	729,081	7.2	0.66	20.61	0.00	107.66	41.22	243.08	110,491	98%
144	25.2	727,346	7.2	0.66	19.61	0.00	107.51	39.23	243.03	110,470	98%
146	23.8	725,668	7.1	0.66	18.67	0.00	107.36	37.34	242.99	110,450	98%
148	22.5	724,045	7.1	0.66	17.77	0.00	107.21	35.54	242.95	110,430	98%
150	21.2	722,477	7.1	0.66	16.91	0.00	107.07	33.83	242.90	110,411	98%
152	20.0	720,962	7.1	0.66	16.10	0.00	106.93	32.20	242.86	110,393	98%
154	18.9	719,498	7.1	0.66	15.33	0.00	106.80	30.66	242.82	110,375	99%
156	17.8	718,083	7.1	0.66	14.60	0.00	106.67	29.20	242.79	110,358	99%
158	16.8	716,716	7.1	0.66	13.90	0.00	106.55	27.80	242.75	110,341	99%
160	15.8	715,395	7.0	0.66	13.24	0.00	106.43	26.48	242.71	110,325	99%
162	15.0	714,119	7.0	0.66	12.61	0.00	106.31	25.22	242.68	110,309	99%
164	14.1	712,886	7.0	0.66	12.02	0.00	106.20	24.03	242.65	110,294	99%
166	13.3	711,695	7.0	0.66	11.45	0.00	106.09	22.90	242.61	110,279	99%
168	12.6	710,545	7.0	0.66	10.91	0.00	105.98	21.82	242.58	110,265	99%
170	11.8	709,433	7.0	0.66	10.40	0.00	105.88	20.80	242.55	110,251	99%
172	11.2	708,359	7.0	0.66	9.91	0.00	105.78	19.83	242.52	110,238	99%
174	10.5	707,321	7.0	0.66	9.45	0.00	105.69	18.90	242.50	110,225	99%
176	9.9	706,318	7.0	0.66	9.01	0.00	105.60	18.02	242.47	110,213	99%
178	9.4	705,349	7.0	0.66	8.60	0.00	105.51	17.19	242.44	110,201	99%
180	8.9	704,413	6.9	0.66	8.20	0.00	105.42	16.40	242.42	110,189	100%
182	8.4	703,507	6.9	0.66	7.82	0.00	105.34	15.65	242.39	110,178	100%
184	7.9	702,632	6.9	0.66	7.47	0.00	105.26	14.93	242.37	110,167	100%
186	7.4	701,786	6.9	0.66	7.13	0.00	105.18	14.25	242.34	110,156	100%
188	7.0	700,969	6.9	0.66	6.80	0.00	105.10	13.61	242.32	110,146	100%
190	6.6	700,178	6.9	0.66	6.50	0.00	105.03	12.99	242.30	110,136	100%
192	6.2	699,413	6.9	0.66	6.20	0.00	104.96	12.41	242.28	110,127	100%
194	5.9	698,674	6.9	0.66	5.93	0.00	104.89	11.85	242.26	110,117	100%
196	5.6	697,959	6.9	0.66	5.66	0.00	104.82	11.32	242.24	110,108	100%
198	5.2	697,267	6.9	0.66	5.41	0.00	104.76	10.82	242.22	110,100	100%
200	4.9	696,597	6.9	0.66	5.17	0.00	104.70	10.35	242.20	110,091	100%
202	4.7	695,950	6.9	0.66	4.95	0.00	104.64	9.89	242.18	110,083	100%
204	4.4	695,323	6.9	0.66	4.73	0.00	104.58	9.46	242.17	110,075	100%

**Sediment Basin #9 Colon Mine Phase 2 Hydrograph
100-Yr Storm**

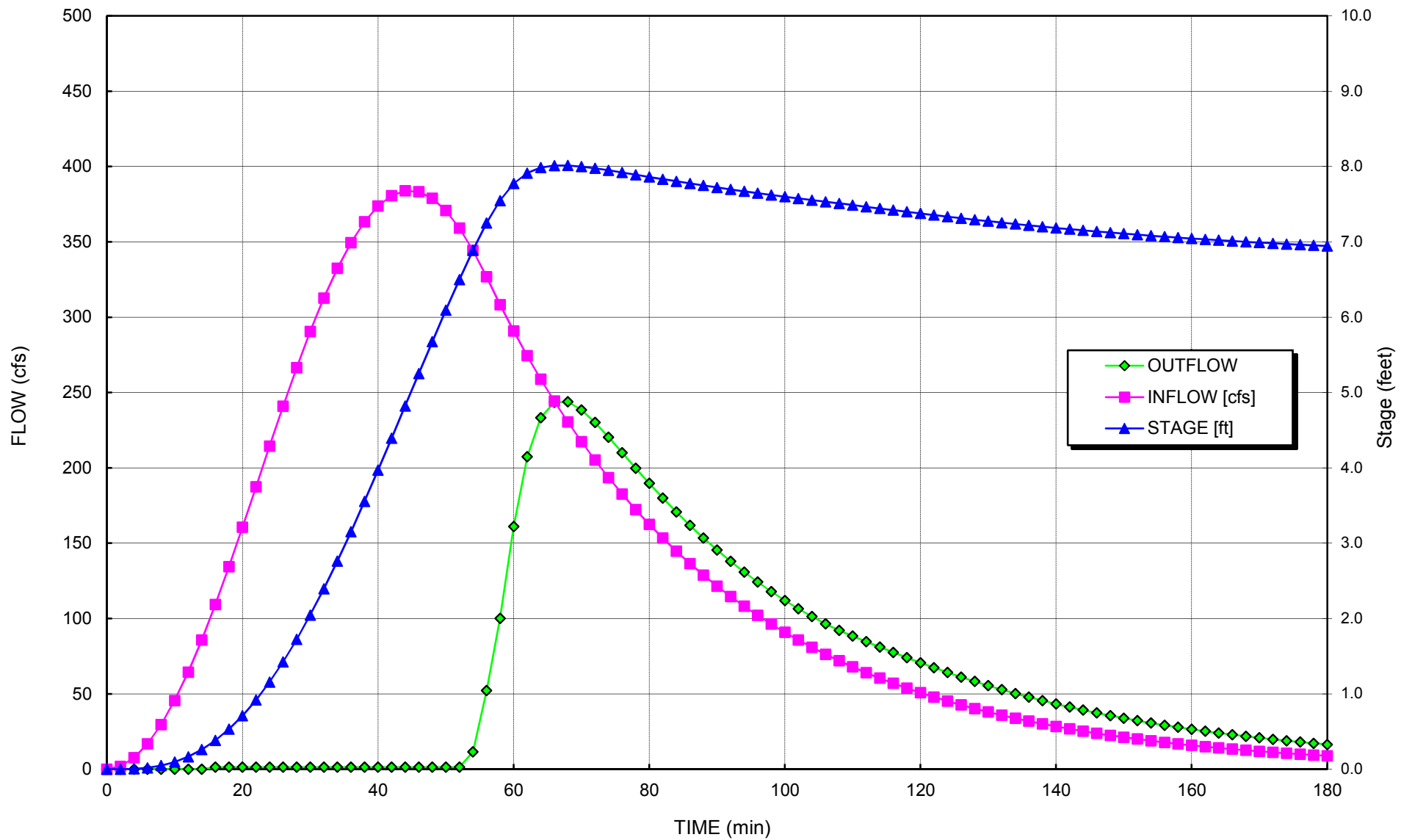

This page intentionally left blank.

Hydrograph Summary Report

Hydraflow Hydrographs Extension for AutoCAD® Civil 3D® 2014 by Autodesk, Inc. v10.3

Hyd. No.	Hydrograph type (origin)	Peak flow (cfs)	Time interval (min)	Time to Peak (min)	Hyd. volume (cuft)	Inflow hyd(s)	Maximum elevation (ft)	Total strge used (cuft)	Hydrograph Description
1	SCS Runoff	32.86	2	716	68,783	----	----	----	BASIN #1
2	SCS Runoff	101.32	2	718	238,246	----	----	----	BASIN #2
3	SCS Runoff	20.57	2	716	44,737	----	----	----	BASIN #3
4	SCS Runoff	77.74	2	718	186,273	----	----	----	BASIN #4
5	SCS Runoff	301.78	2	718	723,090	----	----	----	BASIN #5
6	SCS Runoff	93.60	2	718	224,261	----	----	----	BASIN #6
7	SCS Runoff	85.59	2	718	197,920	----	----	----	BASIN #7
8	SCS Runoff	71.25	2	716	149,115	----	----	----	BASIN #8
9	SCS Runoff	145.70	2	728	541,646	----	----	----	BASIN #9
Basins-Phase 1.gpw					Return Period: 10 Year			Friday, 10 / 31 / 2014	

Hydrograph Report

Hydraflow Hydrographs Extension for AutoCAD® Civil 3D® 2014 by Autodesk, Inc. v10.3

Friday, 10 / 31 / 2014

Hyd. No. 1

BASIN #1

Hydrograph type	= SCS Runoff	Peak discharge	= 32.86 cfs
Storm frequency	= 10 yrs	Time to peak	= 716 min
Time interval	= 2 min	Hyd. volume	= 68,783 cuft
Drainage area	= 5.420 ac	Curve number	= 86*
Basin Slope	= 0.0 %	Hydraulic length	= 0 ft
Tc method	= TR55	Time of conc. (Tc)	= 5.50 min
Total precip.	= 5.28 in	Distribution	= Type II
Storm duration	= 24 hrs	Shape factor	= 484

* Composite (Area/CN) = [(5.420 x 86)] / 5.420

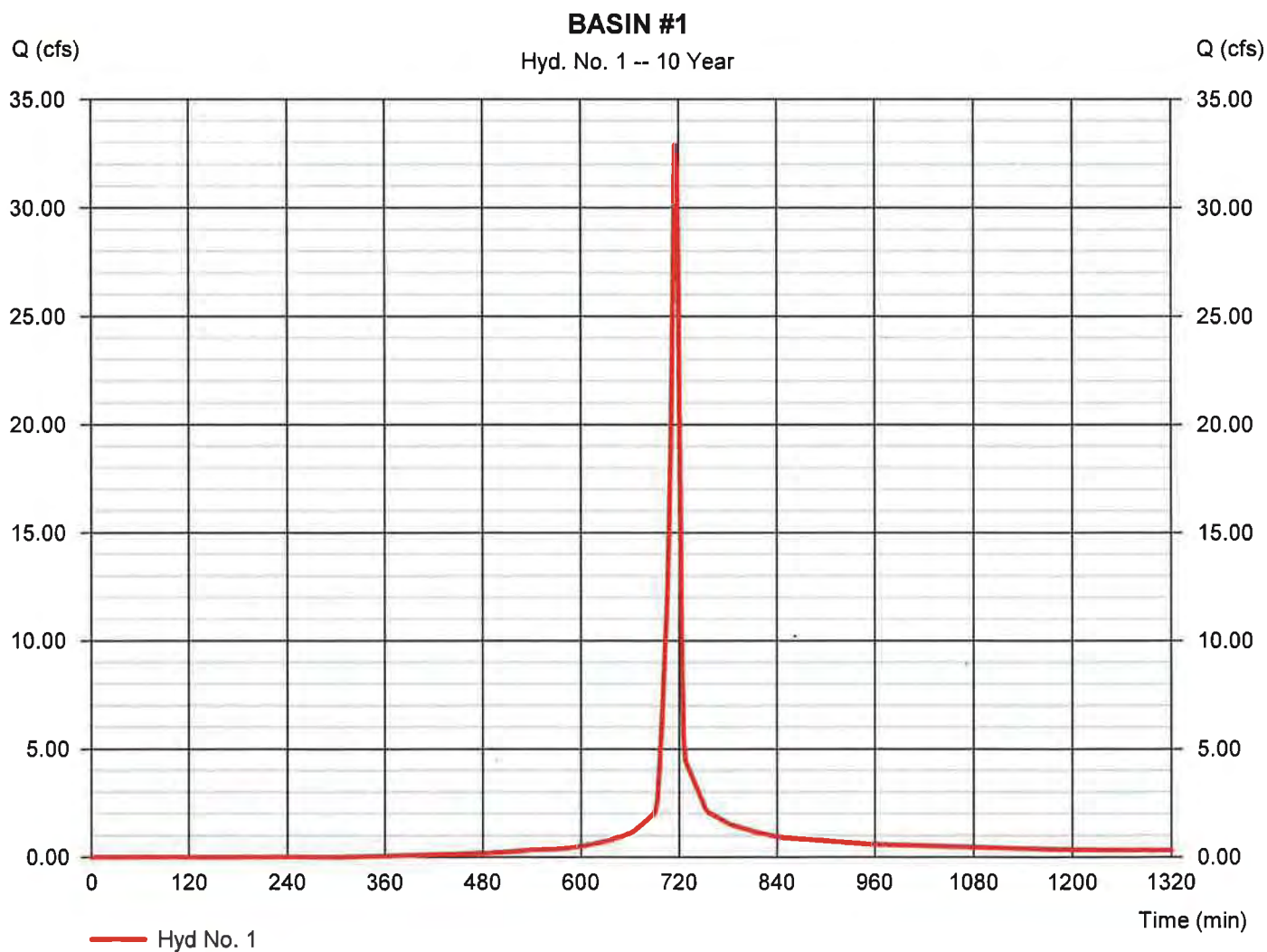

TR55 Tc Worksheet

Hyd. No. 1

BASIN #1

<u>Description</u>	<u>A</u>	<u>B</u>	<u>C</u>	<u>Totals</u>
Sheet Flow				
Manning's n-value	= 0.050	0.011	0.011	
Flow length (ft)	= 100.0	0.0	0.0	
Two-year 24-hr precip. (in)	= 3.62	0.00	0.00	
Land slope (%)	= 2.00	0.00	0.00	
Travel Time (min)	= 3.83	+ 0.00	+ 0.00	= 3.83
Shallow Concentrated Flow				
Flow length (ft)	= 282.46	0.00	0.00	
Watercourse slope (%)	= 7.43	0.00	0.00	
Surface description	= Unpaved	Paved	Paved	
Average velocity (ft/s)	=4.40	0.00	0.00	
Travel Time (min)	= 1.07	+ 0.00	+ 0.00	= 1.07
Channel Flow				
X sectional flow area (sqft)	= 20.00	0.00	0.00	
Wetted perimeter (ft)	= 14.00	0.00	0.00	
Channel slope (%)	= 5.79	0.00	0.00	
Manning's n-value	= 0.050	0.015	0.015	
Velocity (ft/s)	=9.11	0.00	0.00	
Flow length (ft)	{{0}}345.6	0.0	0.0	
Travel Time (min)	= 0.63	+ 0.00	+ 0.00	= 0.63
Total Travel Time, Tc				5.50 min

Hydrograph Report

Hydraflow Hydrographs Extension for AutoCAD® Civil 3D® 2014 by Autodesk, Inc. v10.3

Friday, 10 / 31 / 2014

Hyd. No. 2

BASIN #2

Hydrograph type	= SCS Runoff	Peak discharge	= 101.32 cfs
Storm frequency	= 10 yrs	Time to peak	= 718 min
Time interval	= 2 min	Hyd. volume	= 238,246 cuft
Drainage area	= 17.600 ac	Curve number	= 86*
Basin Slope	= 0.0 %	Hydraulic length	= 0 ft
Tc method	= TR55	Time of conc. (Tc)	= 7.90 min
Total precip.	= 5.28 in	Distribution	= Type II
Storm duration	= 24 hrs	Shape factor	= 484

* Composite (Area/CN) = [(17.600 x 86)] / 17.600

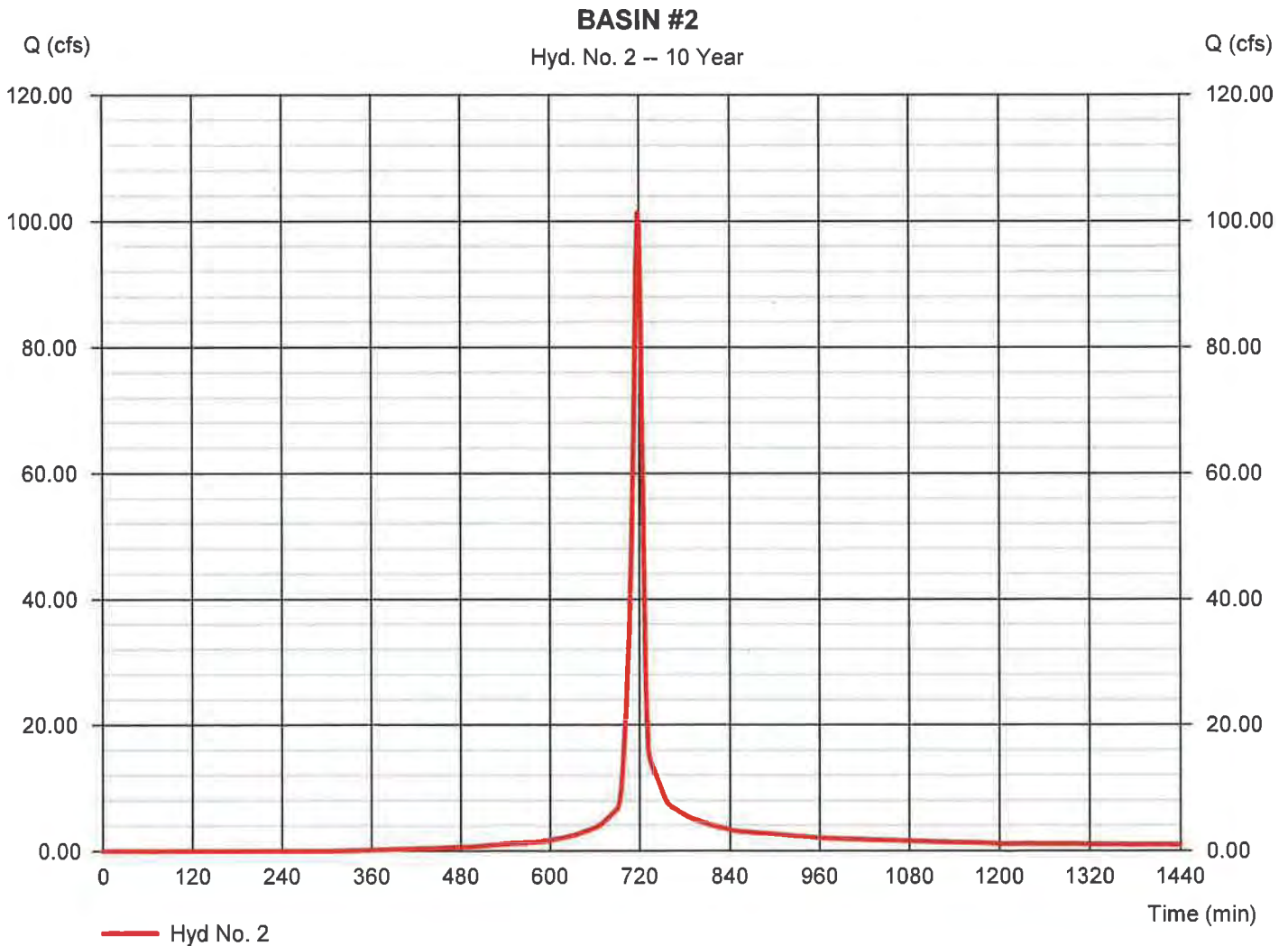

Hyd. No. 2

BASIN #2

<u>Description</u>	<u>A</u>	<u>B</u>	<u>C</u>	<u>Totals</u>
Sheet Flow				
Manning's n-value	= 0.050	0.011	0.011	
Flow length (ft)	= 100.0	0.0	0.0	
Two-year 24-hr precip. (in)	= 3.62	0.00	0.00	
Land slope (%)	= 5.50	0.00	0.00	
Travel Time (min)	= 2.55	+ 0.00	+ 0.00	= 2.55
Shallow Concentrated Flow				
Flow length (ft)	= 771.00	0.00	0.00	
Watercourse slope (%)	= 5.38	0.00	0.00	
Surface description	= Unpaved	Paved	Paved	
Average velocity (ft/s)	=3.74	0.00	0.00	
Travel Time (min)	= 3.43	+ 0.00	+ 0.00	= 3.43
Channel Flow				
X sectional flow area (sqft)	= 10.00	0.00	0.00	
Wetted perimeter (ft)	= 9.00	0.00	0.00	
Channel slope (%)	= 2.70	0.00	0.00	
Manning's n-value	= 0.050	0.015	0.015	
Velocity (ft/s)	=5.25	0.00	0.00	
Flow length (ft)	{{0}}595.4	0.0	0.0	
Travel Time (min)	= 1.89	+ 0.00	+ 0.00	= 1.89
Total Travel Time, Tc				7.90 min

Hydrograph Report

Hydraflow Hydrographs Extension for AutoCAD® Civil 3D® 2014 by Autodesk, Inc. v10.3

Friday, 10 / 31 / 2014

Hyd. No. 3

BASIN #3

Hydrograph type	= SCS Runoff	Peak discharge	= 20.57 cfs
Storm frequency	= 10 yrs	Time to peak	= 716 min
Time interval	= 2 min	Hyd. volume	= 44,737 cuft
Drainage area	= 3.090 ac	Curve number	= 91*
Basin Slope	= 0.0 %	Hydraulic length	= 0 ft
Tc method	= User	Time of conc. (Tc)	= 5.00 min
Total precip.	= 5.28 in	Distribution	= Type II
Storm duration	= 24 hrs	Shape factor	= 484

* Composite (Area/CN) = [(3.090 x 91)] / 3.090

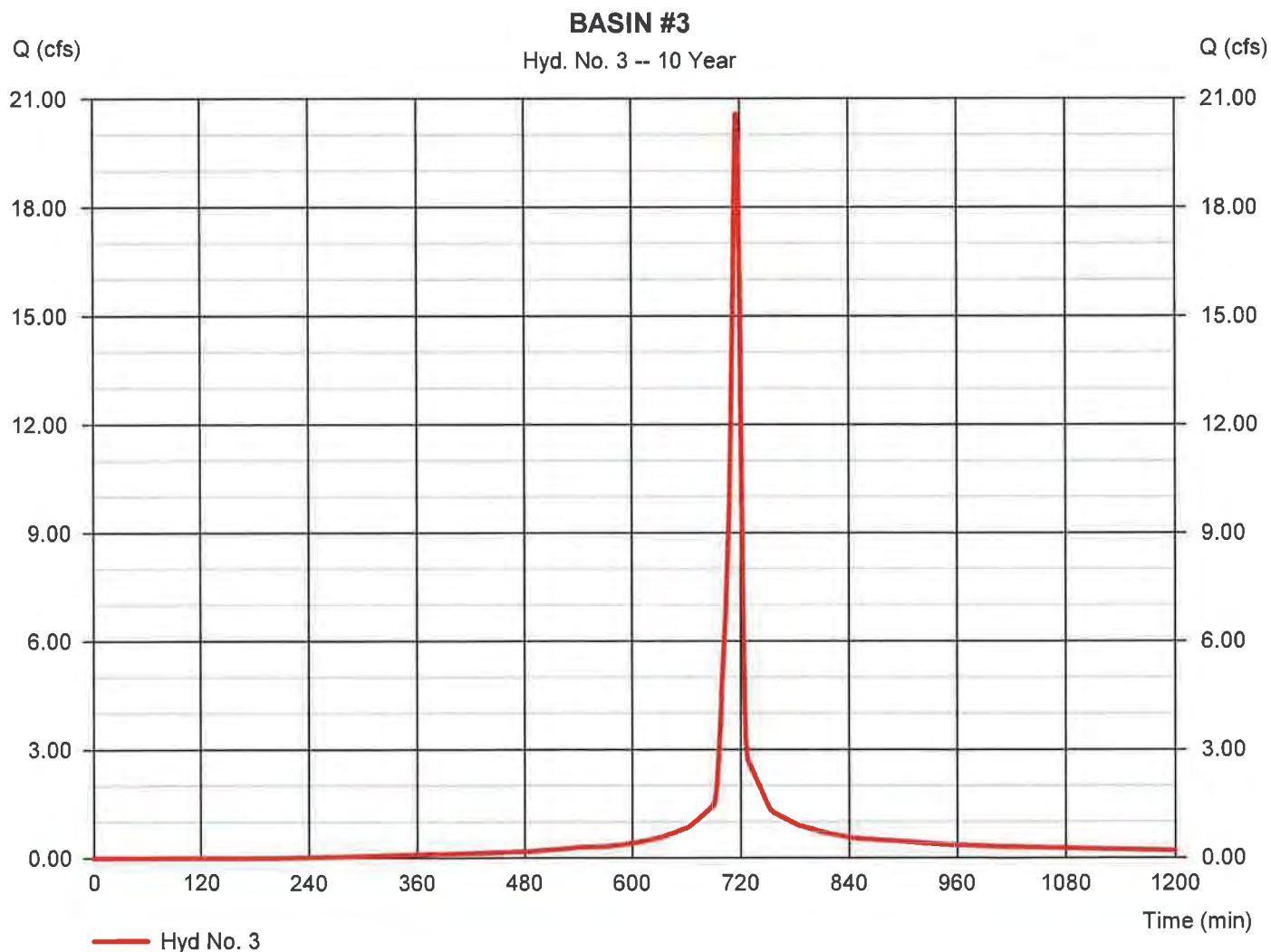

Hydrograph Report

Hyd. No. 4

BASIN #4

Hydrograph type	= SCS Runoff	Peak discharge	= 77.74 cfs
Storm frequency	= 10 yrs	Time to peak	= 718 min
Time interval	= 2 min	Hyd. volume	= 186,273 cuft
Drainage area	= 12.700 ac	Curve number	= 89*
Basin Slope	= 0.0 %	Hydraulic length	= 0 ft
Tc method	= TR55	Time of conc. (Tc)	= 8.60 min
Total precip.	= 5.28 in	Distribution	= Type II
Storm duration	= 24 hrs	Shape factor	= 484

* Composite (Area/CN) = [(5.880 x 86) + (6.820 x 91)] / 12.700

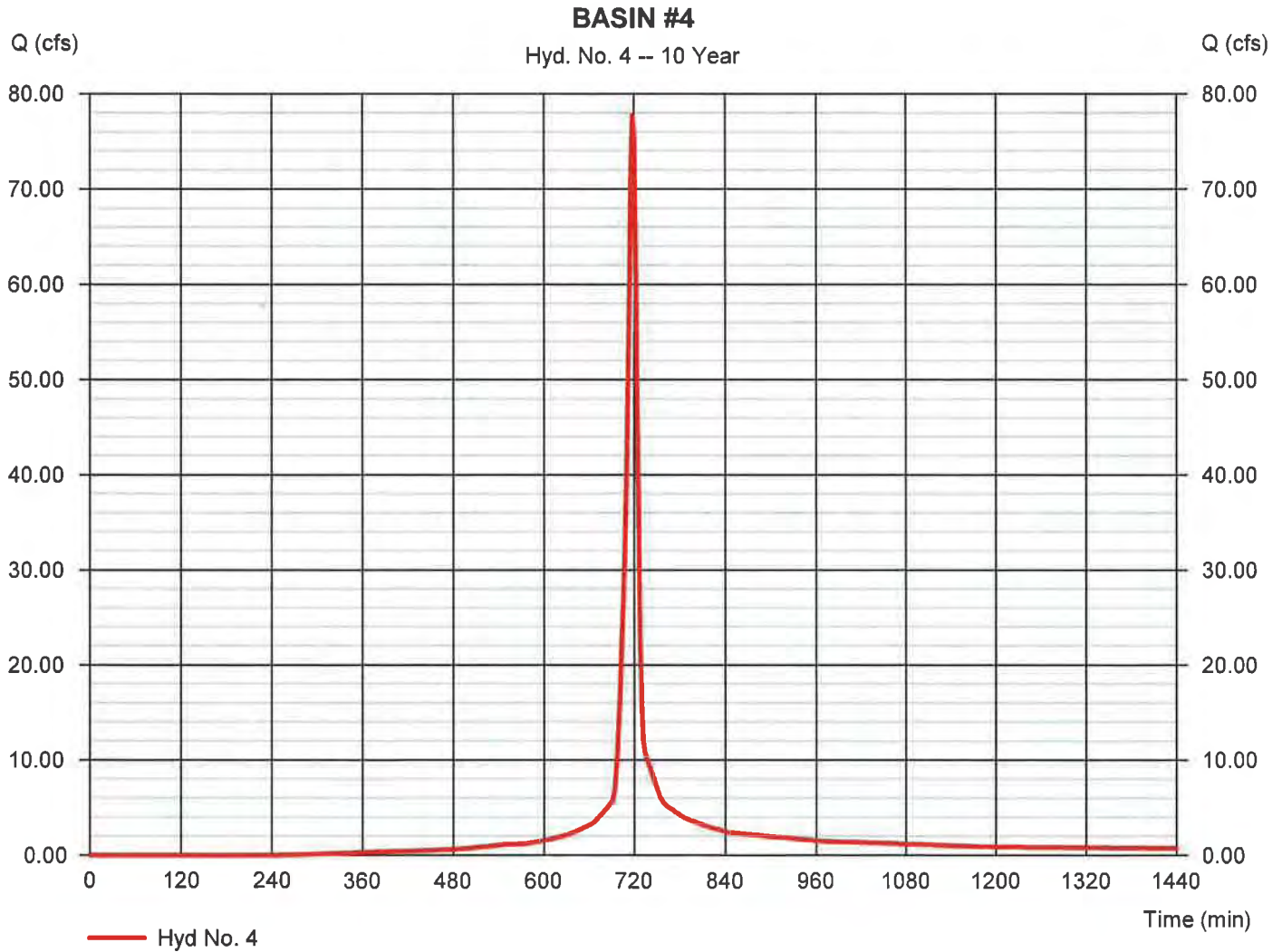

TR55 Tc Worksheet

Hydraflow Hydrographs Extension for AutoCAD® Civil 3D® 2014 by Autodesk, Inc. v10.3

Hyd. No. 4

BASIN #4

<u>Description</u>	<u>A</u>	<u>B</u>	<u>C</u>	<u>Totals</u>
Sheet Flow				
Manning's n-value	= 0.050	0.011	0.011	
Flow length (ft)	= 100.0	0.0	0.0	
Two-year 24-hr precip. (in)	= 3.62	0.00	0.00	
Land slope (%)	= 1.00	0.00	0.00	
Travel Time (min)	= 5.05	+	0.00	+
				0.00
				= 5.05
Shallow Concentrated Flow				
Flow length (ft)	= 252.20	0.00	0.00	
Watercourse slope (%)	= 6.54	0.00	0.00	
Surface description	= Unpaved	Paved	Paved	
Average velocity (ft/s)	=4.13	0.00	0.00	
Travel Time (min)	= 1.02	+	0.00	+
				0.00
				= 1.02
Channel Flow				
X sectional flow area (sqft)	= 20.00	0.00	0.00	
Wetted perimeter (ft)	= 14.00	0.00	0.00	
Channel slope (%)	= 4.11	0.00	0.00	
Manning's n-value	= 0.050	0.015	0.015	
Velocity (ft/s)	=7.67	0.00	0.00	
				0.00
				0.00
Flow length (ft)	{{0}}1144.0	0.0	0.0	
Travel Time (min)	= 2.49	+	0.00	+
				0.00
				= 2.49
Total Travel Time, Tc				8.60 min

Hydrograph Report

Hyd. No. 5

BASIN #5

Hydrograph type	= SCS Runoff	Peak discharge	= 301.78 cfs
Storm frequency	= 10 yrs	Time to peak	= 718 min
Time interval	= 2 min	Hyd. volume	= 723,090 cuft
Drainage area	= 49.300 ac	Curve number	= 89*
Basin Slope	= 0.0 %	Hydraulic length	= 0 ft
Tc method	= TR55	Time of conc. (Tc)	= 9.50 min
Total precip.	= 5.28 in	Distribution	= Type II
Storm duration	= 24 hrs	Shape factor	= 484

* Composite (Area/CN) = [(24.900 x 86) + (21.230 x 91) + (3.170 x 94)] / 49.300

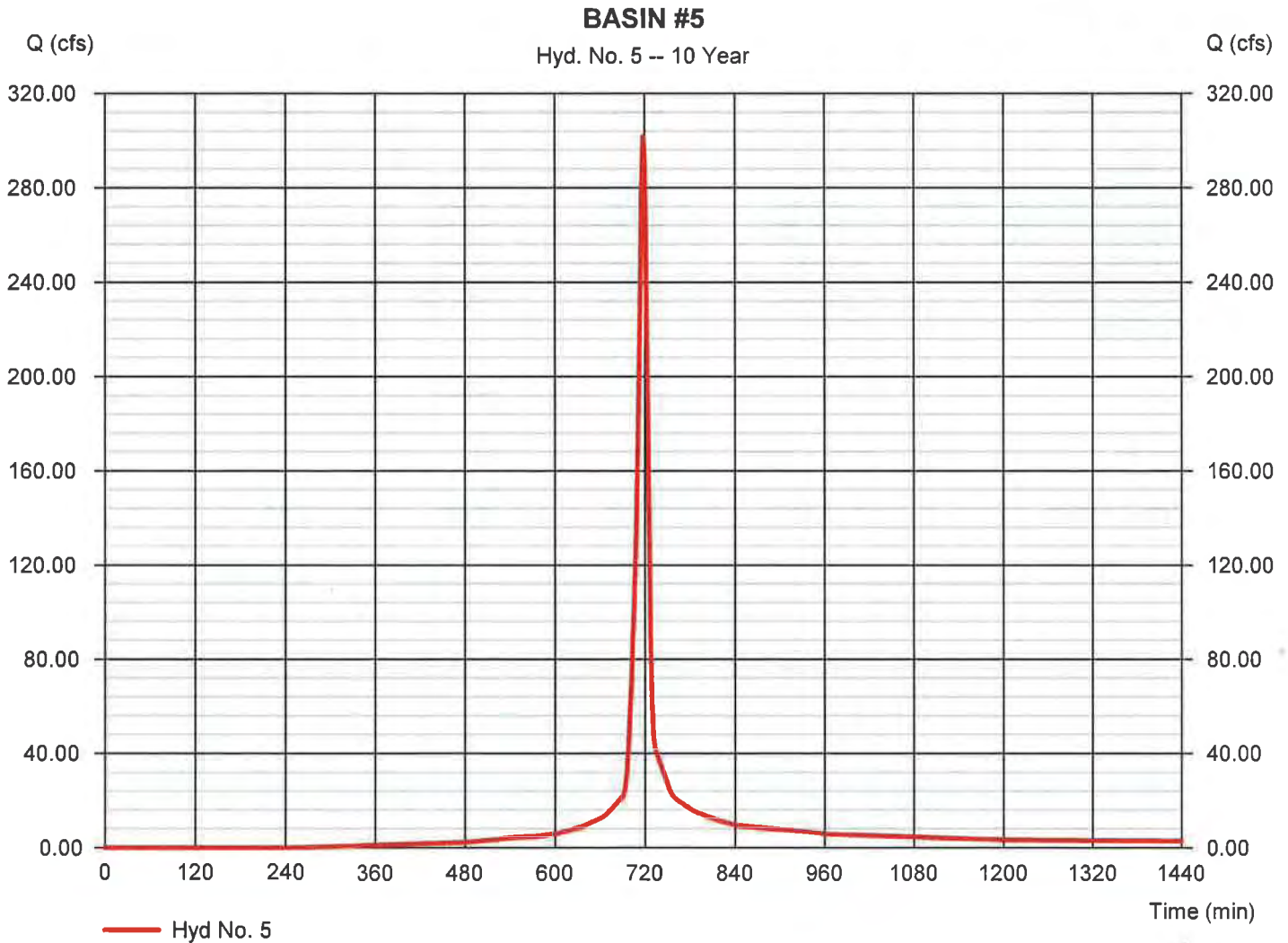

TR55 Tc Worksheet

Hydraflow Hydrographs Extension for AutoCAD® Civil 3D® 2014 by Autodesk, Inc. v10.3

Hyd. No. 5

BASIN #5

<u>Description</u>	<u>A</u>	<u>B</u>	<u>C</u>	<u>Totals</u>
Sheet Flow				
Manning's n-value	= 0.050	0.011	0.011	
Flow length (ft)	= 100.0	0.0	0.0	
Two-year 24-hr precip. (in)	= 3.62	0.00	0.00	
Land slope (%)	= 2.00	0.00	0.00	
Travel Time (min)	= 3.83	+	0.00	+
				= 3.83
Shallow Concentrated Flow				
Flow length (ft)	= 316.00	0.00	0.00	
Watercourse slope (%)	= 8.90	0.00	0.00	
Surface description	= Unpaved	Paved	Paved	
Average velocity (ft/s)	=4.81	0.00	0.00	
Travel Time (min)	= 1.09	+	0.00	+
				= 1.09
Channel Flow				
X sectional flow area (sqft)	= 20.00	0.00	0.00	
Wetted perimeter (ft)	= 14.00	0.00	0.00	
Channel slope (%)	= 2.30	0.00	0.00	
Manning's n-value	= 0.050	0.015	0.015	
Velocity (ft/s)	=5.74	0.00	0.00	
Flow length (ft)	{{0}}1588.0	0.0	0.0	
Travel Time (min)	= 4.61	+	0.00	+
				= 4.61
Total Travel Time, Tc				9.50 min

Hydrograph Report

Hyd. No. 6

BASIN #6

Hydrograph type	= SCS Runoff	Peak discharge	= 93.60 cfs
Storm frequency	= 10 yrs	Time to peak	= 718 min
Time interval	= 2 min	Hyd. volume	= 224,261 cuft
Drainage area	= 15.290 ac	Curve number	= 89*
Basin Slope	= 0.0 %	Hydraulic length	= 0 ft
Tc method	= TR55	Time of conc. (Tc)	= 8.30 min
Total precip.	= 5.28 in	Distribution	= Type II
Storm duration	= 24 hrs	Shape factor	= 484

* Composite (Area/CN) = [(5.550 x 86) + (9.740 x 91)] / 15.290

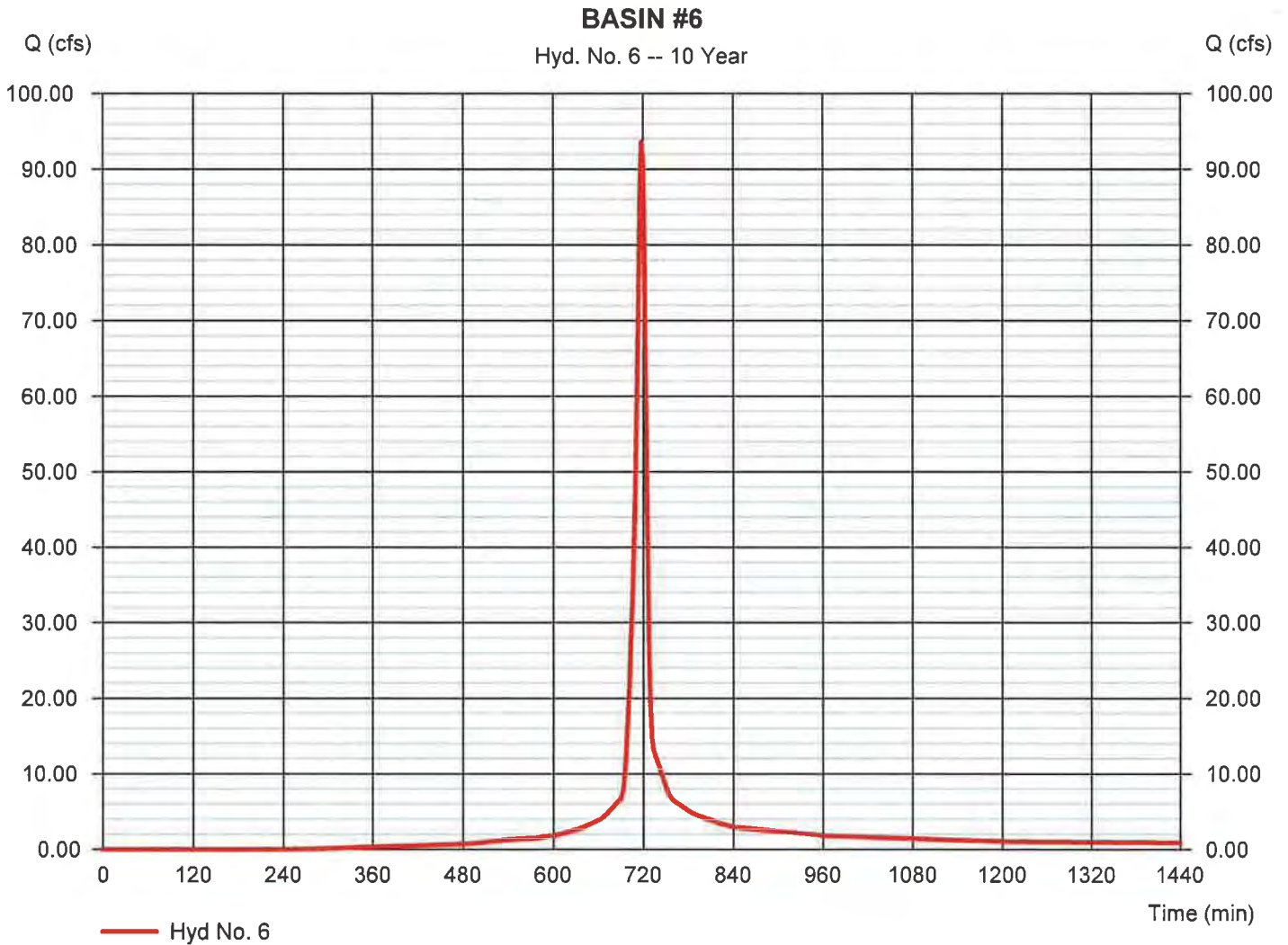

TR55 Tc Worksheet

Hydraflow Hydrographs Extension for AutoCAD® Civil 3D® 2014 by Autodesk, Inc. v10.3

Hyd. No. 6

BASIN #6

<u>Description</u>	<u>A</u>	<u>B</u>	<u>C</u>	<u>Totals</u>
Sheet Flow				
Manning's n-value	= 0.050	0.011	0.011	
Flow length (ft)	= 100.0	0.0	0.0	
Two-year 24-hr precip. (in)	= 3.62	0.00	0.00	
Land slope (%)	= 1.00	0.00	0.00	
Travel Time (min)	= 5.05	+ 0.00	+ 0.00	= 5.05
Shallow Concentrated Flow				
Flow length (ft)	= 592.93	0.00	0.00	
Watercourse slope (%)	= 6.62	0.00	0.00	
Surface description	= Unpaved	Paved	Paved	
Average velocity (ft/s)	=4.15	0.00	0.00	
Travel Time (min)	= 2.38	+ 0.00	+ 0.00	= 2.38
Channel Flow				
X sectional flow area (sqft)	= 20.00	0.00	0.00	
Wetted perimeter (ft)	= 14.00	0.00	0.00	
Channel slope (%)	= 4.13	0.00	0.00	
Manning's n-value	= 0.050	0.015	0.015	
Velocity (ft/s)	=7.69	0.00	0.00	
Flow length (ft)	{{0}}392.9	0.0	0.0	
Travel Time (min)	= 0.85	+ 0.00	+ 0.00	= 0.85
Total Travel Time, Tc				8.30 min

Hydrograph Report

Hyd. No. 7

BASIN #7

Hydrograph type	= SCS Runoff	Peak discharge	= 85.59 cfs
Storm frequency	= 10 yrs	Time to peak	= 718 min
Time interval	= 2 min	Hyd. volume	= 197,920 cuft
Drainage area	= 16.370 ac	Curve number	= 82*
Basin Slope	= 0.0 %	Hydraulic length	= 0 ft
Tc method	= TR55	Time of conc. (Tc)	= 7.40 min
Total precip.	= 5.28 in	Distribution	= Type II
Storm duration	= 24 hrs	Shape factor	= 484

* Composite (Area/CN) = [(7.330 x 86) + (5.180 x 91) + (3.330 x 61) + (0.530 x 74)] / 16.370

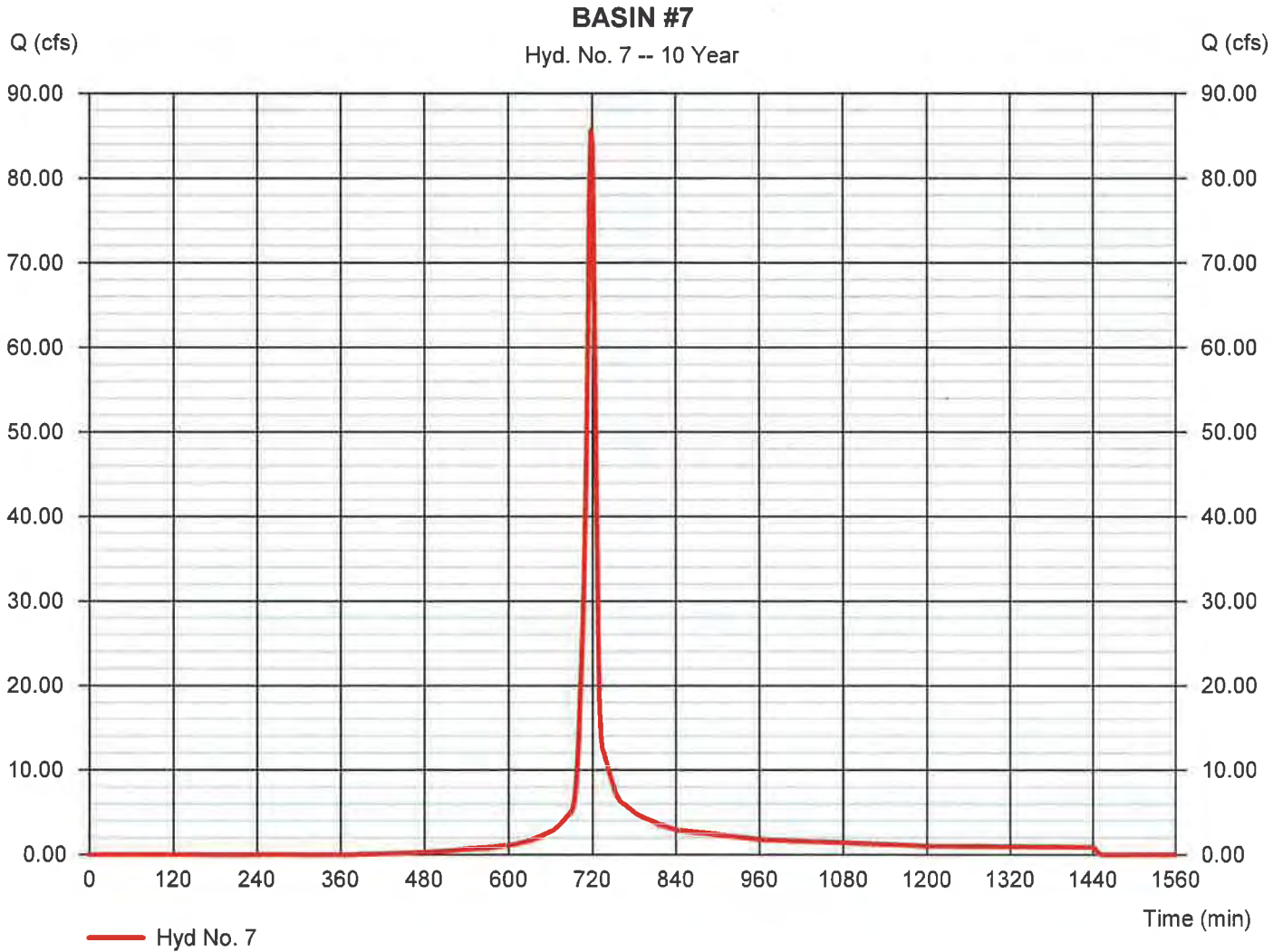

TR55 Tc Worksheet

Hydraflow Hydrographs Extension for AutoCAD® Civil 3D® 2014 by Autodesk, Inc. v10.3

Hyd. No. 7

BASIN #7

<u>Description</u>	<u>A</u>	<u>B</u>	<u>C</u>	<u>Totals</u>
Sheet Flow				
Manning's n-value	= 0.050	0.011	0.011	
Flow length (ft)	= 100.0	0.0	0.0	
Two-year 24-hr precip. (in)	= 3.62	0.00	0.00	
Land slope (%)	= 1.00	0.00	0.00	
Travel Time (min)	= 5.05	+ 0.00	+ 0.00	= 5.05
Shallow Concentrated Flow				
Flow length (ft)	= 290.20	0.00	0.00	
Watercourse slope (%)	= 10.33	0.00	0.00	
Surface description	= Unpaved	Paved	Paved	
Average velocity (ft/s)	=5.19	0.00	0.00	
Travel Time (min)	= 0.93	+ 0.00	+ 0.00	= 0.93
Channel Flow				
X sectional flow area (sqft)	= 20.00	0.00	0.00	
Wetted perimeter (ft)	= 14.00	0.00	0.00	
Channel slope (%)	= 4.10	0.00	0.00	
Manning's n-value	= 0.050	0.015	0.015	
Velocity (ft/s)	=7.66	0.00	0.00	
Flow length (ft)	{{0}}658.3	0.0	0.0	
Travel Time (min)	= 1.43	+ 0.00	+ 0.00	= 1.43
Total Travel Time, Tc				7.40 min

Hydrograph Report

Hyd. No. 8

BASIN #8

Hydrograph type	= SCS Runoff	Peak discharge	= 71.25 cfs
Storm frequency	= 10 yrs	Time to peak	= 716 min
Time interval	= 2 min	Hyd. volume	= 149,115 cuft
Drainage area	= 11.750 ac	Curve number	= 86*
Basin Slope	= 0.0 %	Hydraulic length	= 0 ft
Tc method	= User	Time of conc. (Tc)	= 5.00 min
Total precip.	= 5.28 in	Distribution	= Type II
Storm duration	= 24 hrs	Shape factor	= 484

* Composite (Area/CN) = [(11.750 x 86)] / 11.750

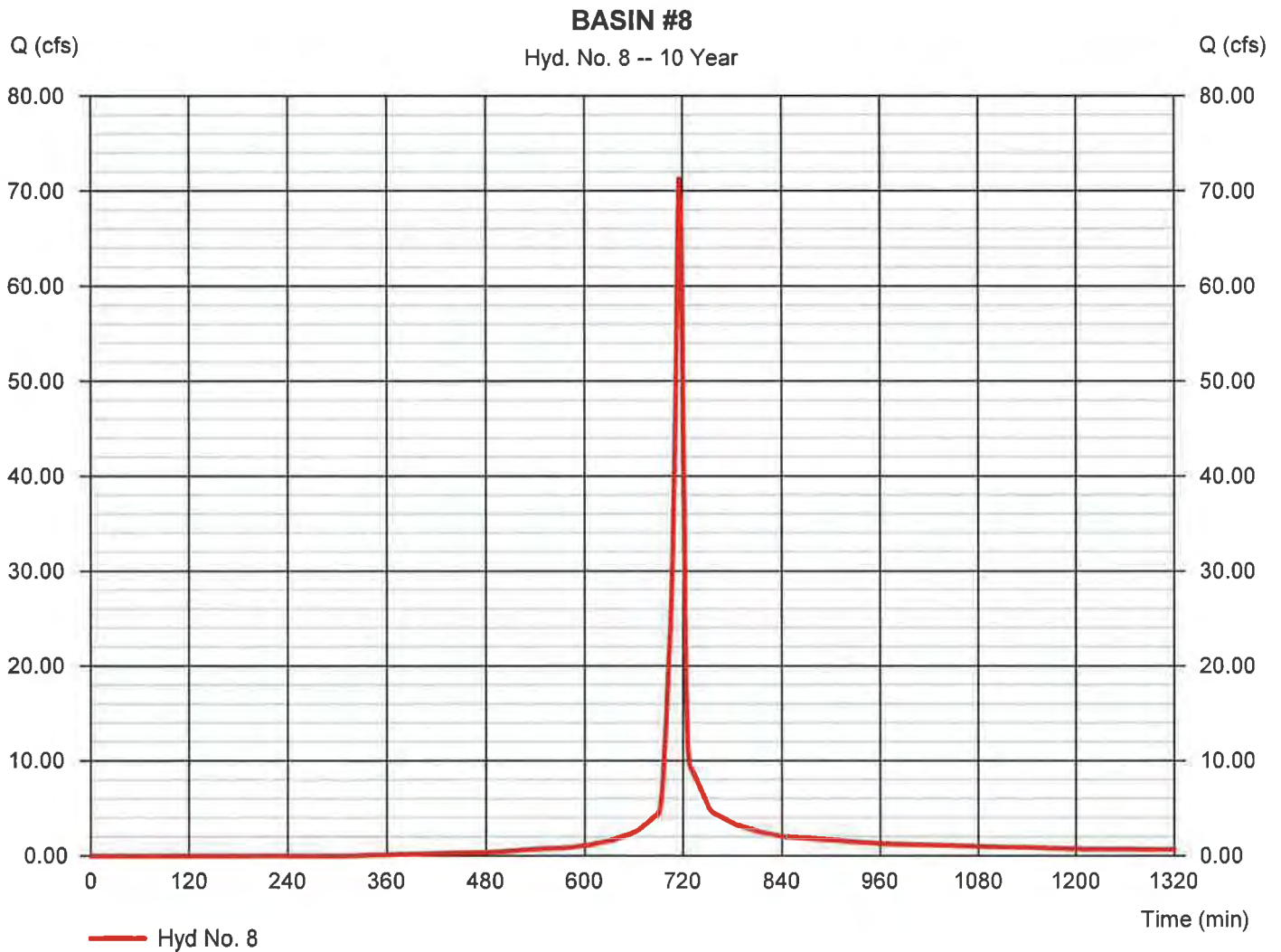

Hydrograph Report

Hydraflow Hydrographs Extension for AutoCAD® Civil 3D® 2014 by Autodesk, Inc. v10.3

Friday, 10 / 31 / 2014

Hyd. No. 9

BASIN #9

Hydrograph type	= SCS Runoff	Peak discharge	= 145.70 cfs
Storm frequency	= 10 yrs	Time to peak	= 728 min
Time interval	= 2 min	Hyd. volume	= 541,646 cuft
Drainage area	= 62.750 ac	Curve number	= 72*
Basin Slope	= 0.0 %	Hydraulic length	= 0 ft
Tc method	= TR55	Time of conc. (Tc)	= 26.80 min
Total precip.	= 5.28 in	Distribution	= Type II
Storm duration	= 24 hrs	Shape factor	= 484

* Composite (Area/CN) = [(32.830 x 86) + (16.030 x 55) + (9.190 x 91)] / 62.750

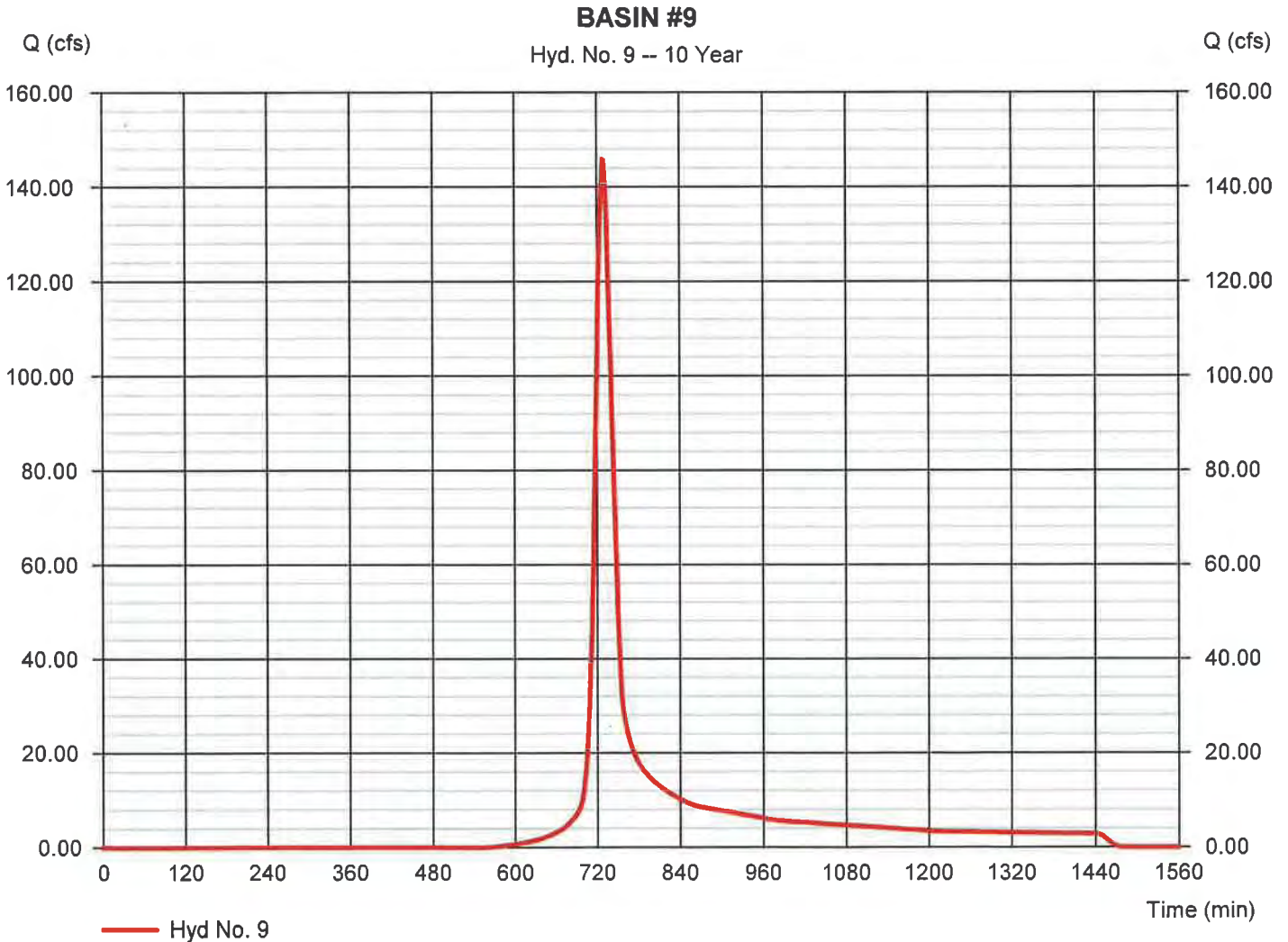

Hyd. No. 9

BASIN #9

<u>Description</u>	<u>A</u>	<u>B</u>	<u>C</u>	<u>Totals</u>
Sheet Flow				
Manning's n-value	= 0.400	0.011	0.011	
Flow length (ft)	= 100.0	0.0	0.0	
Two-year 24-hr precip. (in)	= 3.62	0.00	0.00	
Land slope (%)	= 1.50	0.00	0.00	
Travel Time (min)	= 22.65	+ 0.00	+ 0.00	= 22.65
Shallow Concentrated Flow				
Flow length (ft)	= 230.00	0.00	0.00	
Watercourse slope (%)	= 7.80	0.00	0.00	
Surface description	= Unpaved	Paved	Paved	
Average velocity (ft/s)	=4.51	0.00	0.00	
Travel Time (min)	= 0.85	+ 0.00	+ 0.00	= 0.85
Channel Flow				
X sectional flow area (sqft)	= 20.00	0.00	0.00	
Wetted perimeter (ft)	= 14.00	0.00	0.00	
Channel slope (%)	= 3.30	0.00	0.00	
Manning's n-value	= 0.050	0.015	0.015	
Velocity (ft/s)	=6.87	0.00	0.00	
Flow length (ft)	{{0}}1351.0	0.0	0.0	
Travel Time (min)	= 3.28	+ 0.00	+ 0.00	= 3.28
Total Travel Time, Tc				26.80 min

Hydrograph Summary Report

Hydraflow Hydrographs Extension for AutoCAD® Civil 3D® 2014 by Autodesk, Inc. v10.3

Hyd. No.	Hydrograph type (origin)	Peak flow (cfs)	Time interval (min)	Time to Peak (min)	Hyd. volume (cuft)	Inflow hyd(s)	Maximum elevation (ft)	Total strge used (cuft)	Hydrograph Description
1	SCS Runoff	40.68	2	716	86,249	----	----	----	BASIN #1
2	SCS Runoff	125.58	2	718	298,742	----	----	----	BASIN #2
3	SCS Runoff	24.96	2	716	55,013	----	----	----	BASIN #3
4	SCS Runoff	95.13	2	718	230,828	----	----	----	BASIN #4
5	SCS Runoff	369.28	2	718	896,050	----	----	----	BASIN #5
6	SCS Runoff	114.53	2	718	277,903	----	----	----	BASIN #6
7	SCS Runoff	108.11	2	718	252,279	----	----	----	BASIN #7
8	SCS Runoff	88.20	2	716	186,979	----	----	----	BASIN #8
9	SCS Runoff	196.26	2	728	722,837	----	----	----	BASIN #9
Basins-Phase 1.gpw					Return Period: 25 Year			Friday, 10 / 31 / 2014	

Hydrograph Report

Hyd. No. 1

BASIN #1

Hydrograph type	= SCS Runoff	Peak discharge	= 40.68 cfs
Storm frequency	= 25 yrs	Time to peak	= 716 min
Time interval	= 2 min	Hyd. volume	= 86,249 cuft
Drainage area	= 5.420 ac	Curve number	= 86*
Basin Slope	= 0.0 %	Hydraulic length	= 0 ft
Tc method	= TR55	Time of conc. (Tc)	= 5.50 min
Total precip.	= 6.28 in	Distribution	= Type II
Storm duration	= 24 hrs	Shape factor	= 484

* Composite (Area/CN) = [(5.420 x 86)] / 5.420

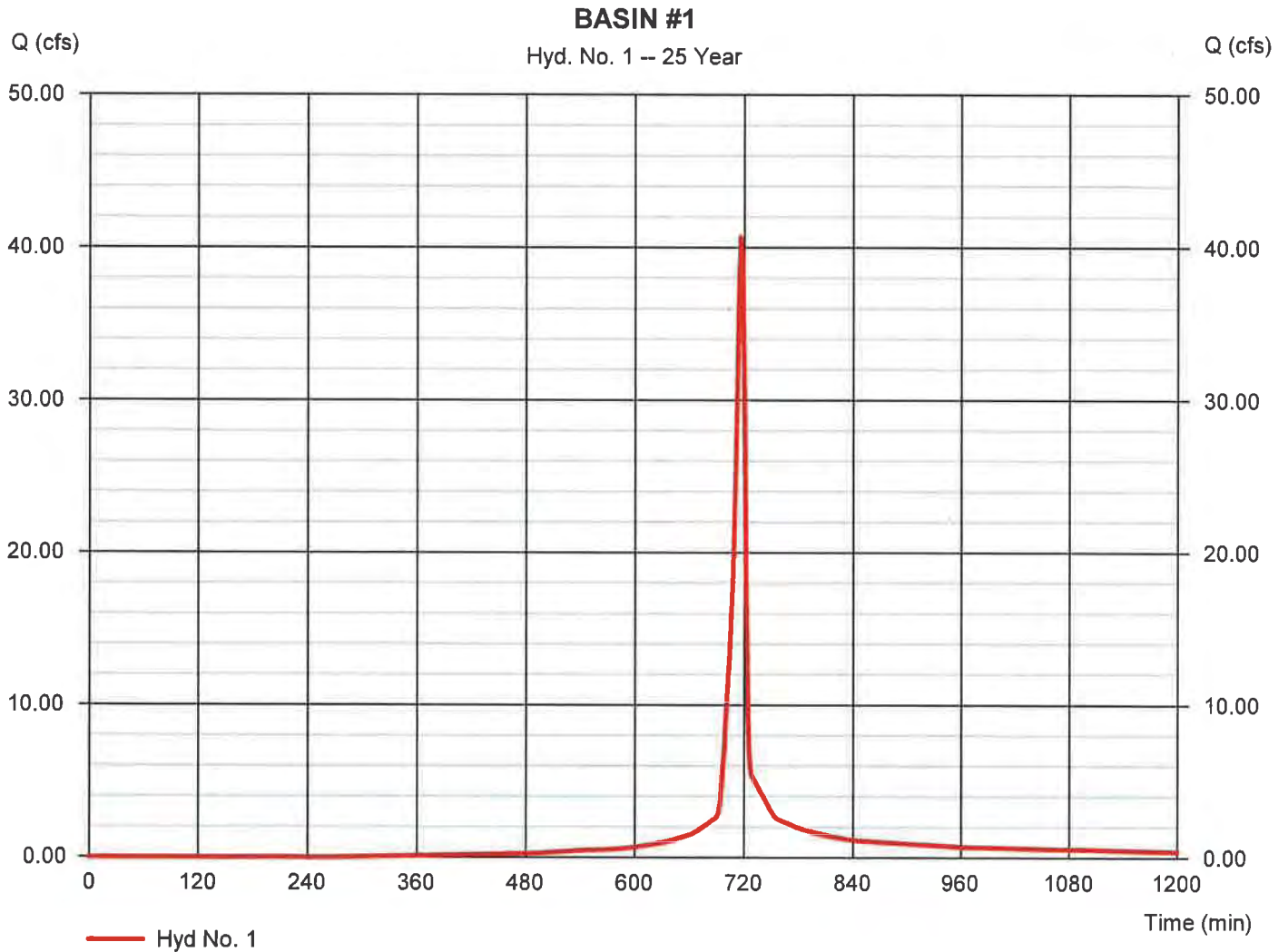

Hydrograph Report

Hydraflow Hydrographs Extension for AutoCAD® Civil 3D® 2014 by Autodesk, Inc. v10.3

Friday, 10 / 31 / 2014

Hyd. No. 2

BASIN #2

Hydrograph type	= SCS Runoff	Peak discharge	= 125.58 cfs
Storm frequency	= 25 yrs	Time to peak	= 718 min
Time interval	= 2 min	Hyd. volume	= 298,742 cuft
Drainage area	= 17.600 ac	Curve number	= 86*
Basin Slope	= 0.0 %	Hydraulic length	= 0 ft
Tc method	= TR55	Time of conc. (Tc)	= 7.90 min
Total precip.	= 6.28 in	Distribution	= Type II
Storm duration	= 24 hrs	Shape factor	= 484

* Composite (Area/CN) = [(17.600 x 86)] / 17.600

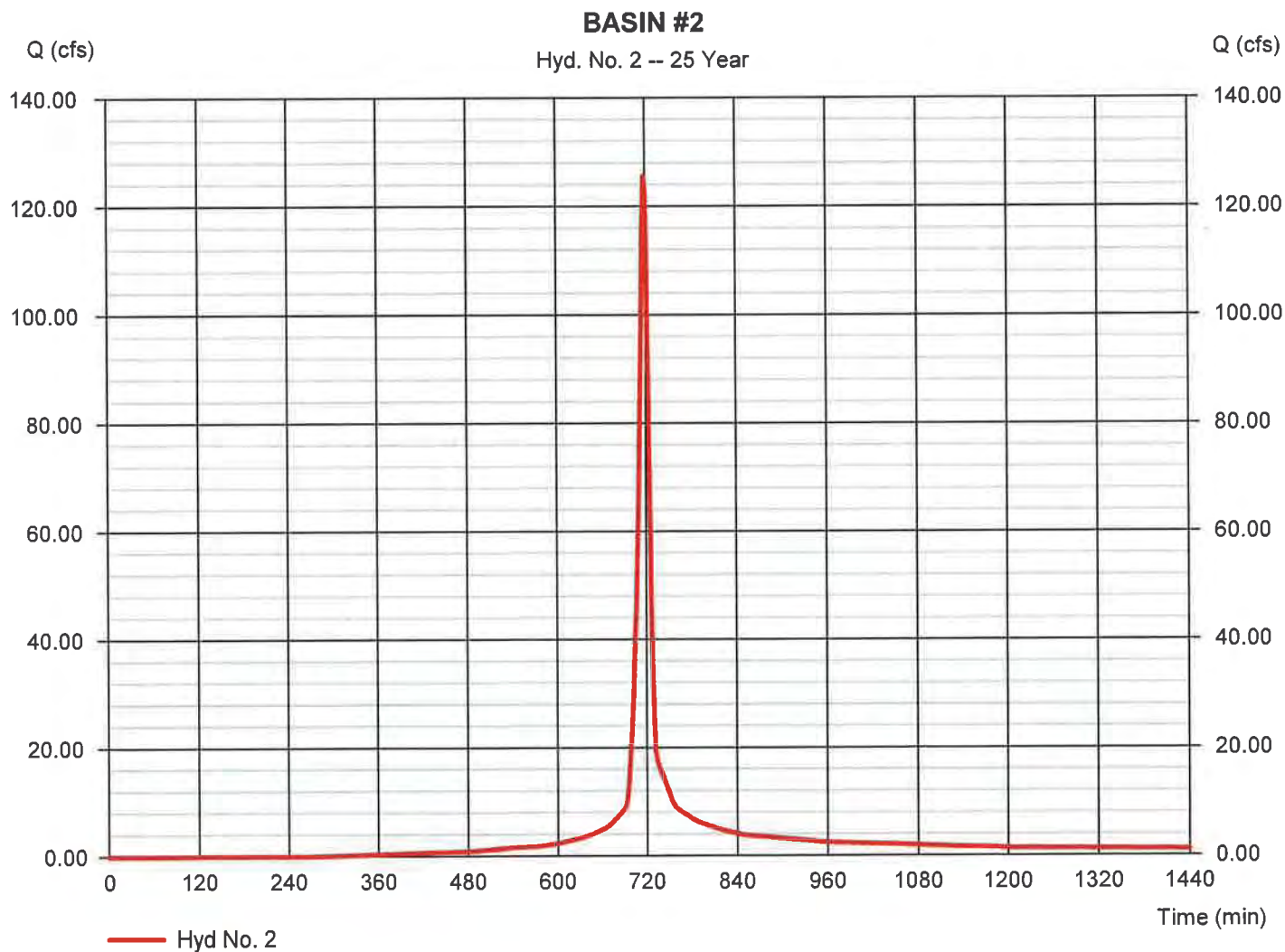

Hyd. No. 3

BASIN #3

Hydrograph type	= SCS Runoff	Peak discharge	= 24.96 cfs
Storm frequency	= 25 yrs	Time to peak	= 716 min
Time interval	= 2 min	Hyd. volume	= 55,013 cuft
Drainage area	= 3.090 ac	Curve number	= 91*
Basin Slope	= 0.0 %	Hydraulic length	= 0 ft
Tc method	= User	Time of conc. (Tc)	= 5.00 min
Total precip.	= 6.28 in	Distribution	= Type II
Storm duration	= 24 hrs	Shape factor	= 484

* Composite (Area/CN) = [(3.090 x 91)] / 3.090

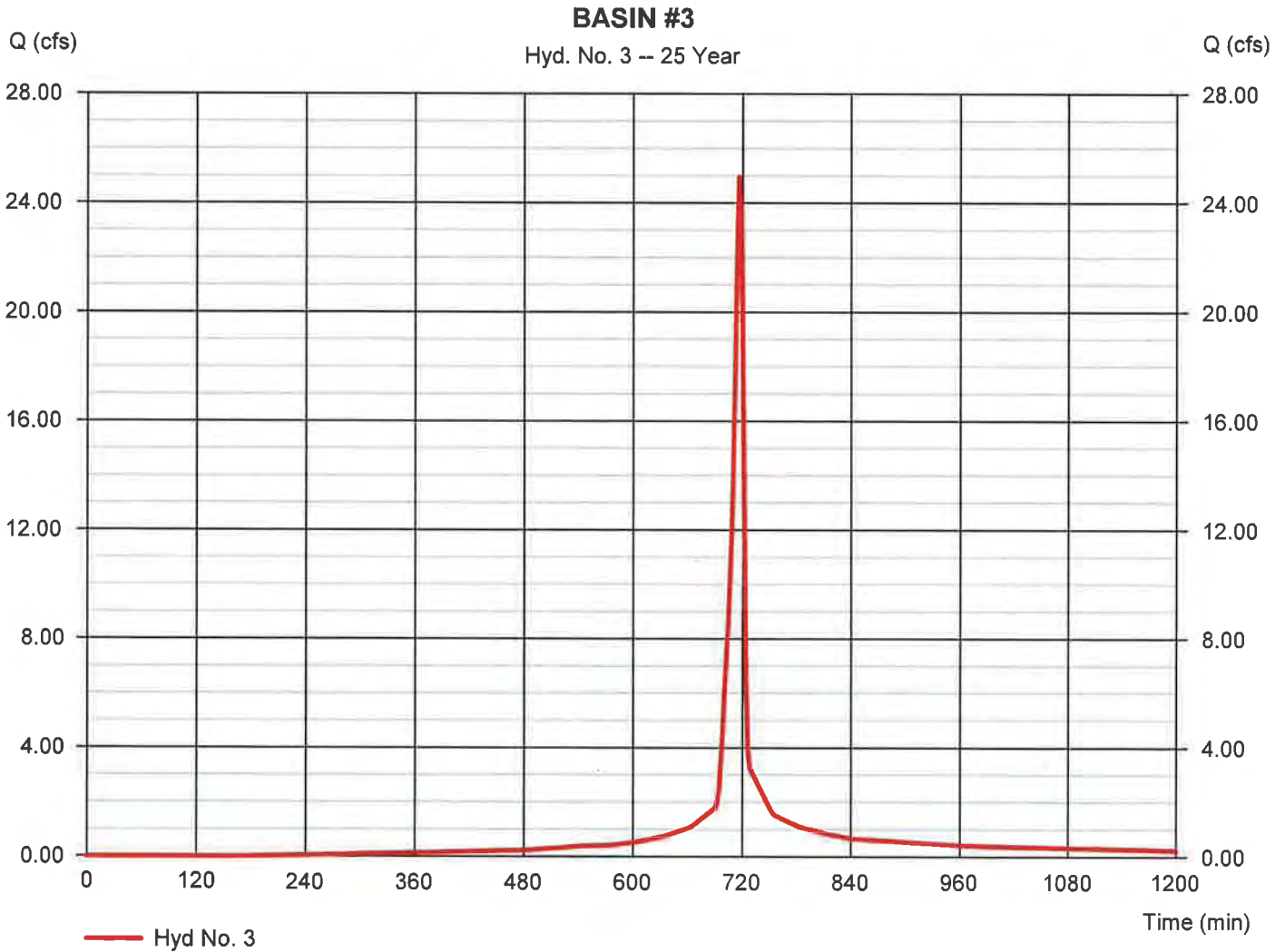

Hydrograph Report

Hydraflow Hydrographs Extension for AutoCAD® Civil 3D® 2014 by Autodesk, Inc. v10.3

Friday, 10 / 31 / 2014

Hyd. No. 4

BASIN #4

Hydrograph type	= SCS Runoff	Peak discharge	= 95.13 cfs
Storm frequency	= 25 yrs	Time to peak	= 718 min
Time interval	= 2 min	Hyd. volume	= 230,828 cuft
Drainage area	= 12.700 ac	Curve number	= 89*
Basin Slope	= 0.0 %	Hydraulic length	= 0 ft
Tc method	= TR55	Time of conc. (Tc)	= 8.60 min
Total precip.	= 6.28 in	Distribution	= Type II
Storm duration	= 24 hrs	Shape factor	= 484

* Composite (Area/CN) = [(5.880 x 86) + (6.820 x 91)] / 12.700

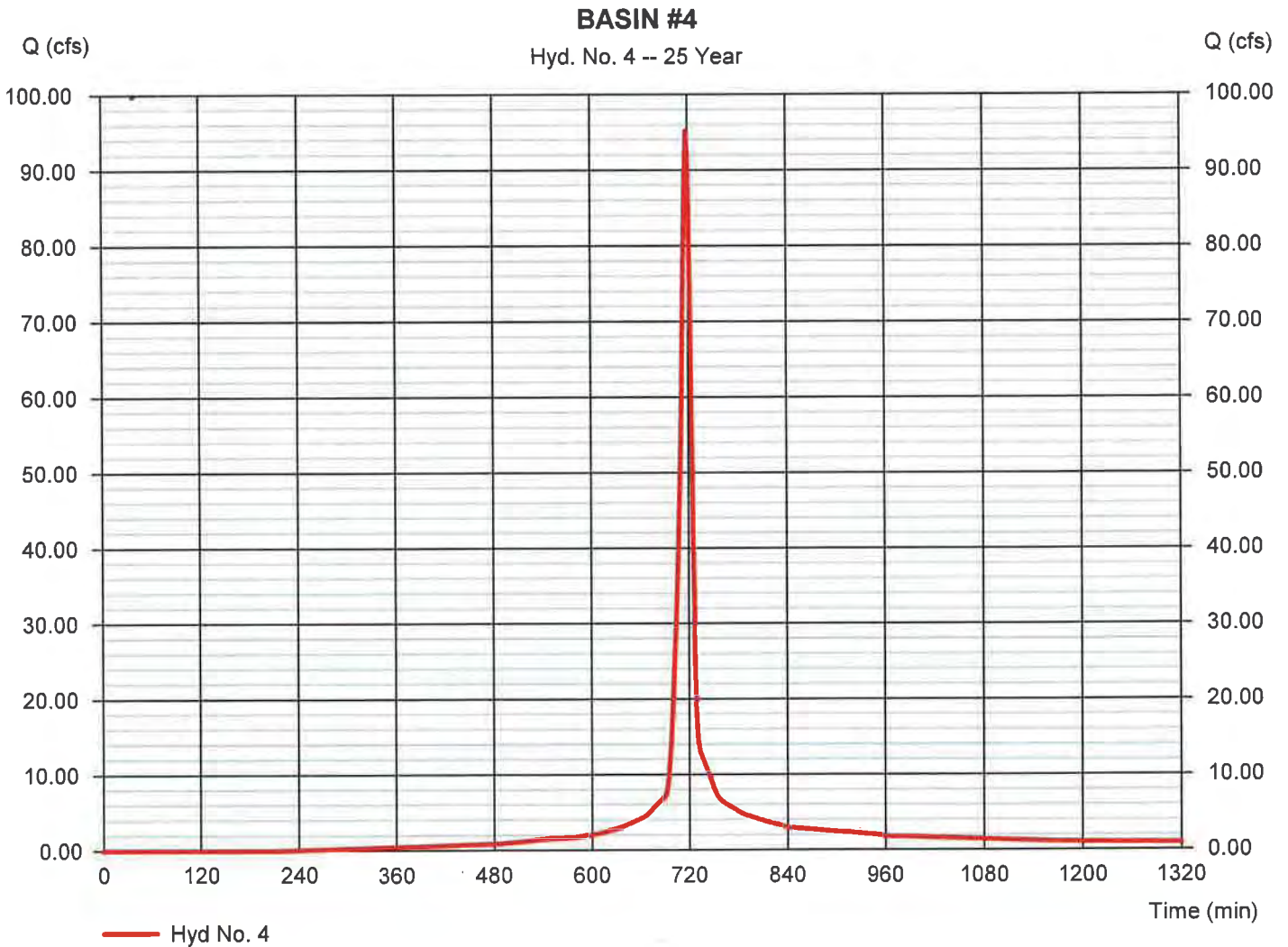

Hydrograph Report

Hyd. No. 5

BASIN #5

Hydrograph type	= SCS Runoff	Peak discharge	= 369.28 cfs
Storm frequency	= 25 yrs	Time to peak	= 718 min
Time interval	= 2 min	Hyd. volume	= 896,050 cuft
Drainage area	= 49.300 ac	Curve number	= 89*
Basin Slope	= 0.0 %	Hydraulic length	= 0 ft
Tc method	= TR55	Time of conc. (Tc)	= 9.50 min
Total precip.	= 6.28 in	Distribution	= Type II
Storm duration	= 24 hrs	Shape factor	= 484

* Composite (Area/CN) = [(24.900 x 86) + (21.230 x 91) + (3.170 x 94)] / 49.300

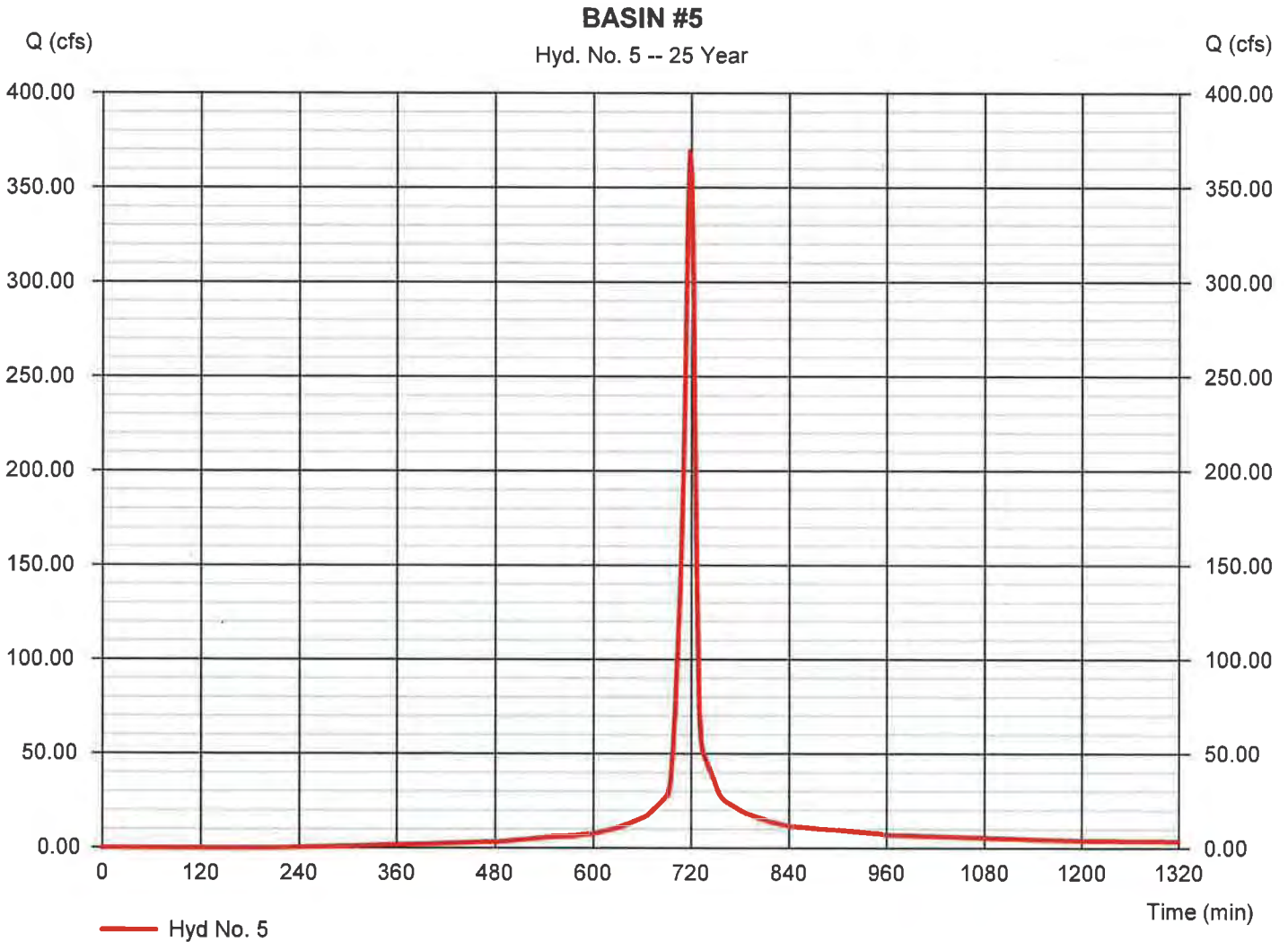

Hydrograph Report

Hydraflow Hydrographs Extension for AutoCAD® Civil 3D® 2014 by Autodesk, Inc. v10.3

Friday, 10 / 31 / 2014

Hyd. No. 6

BASIN #6

Hydrograph type	= SCS Runoff	Peak discharge	= 114.53 cfs
Storm frequency	= 25 yrs	Time to peak	= 718 min
Time interval	= 2 min	Hyd. volume	= 277,903 cuft
Drainage area	= 15.290 ac	Curve number	= 89*
Basin Slope	= 0.0 %	Hydraulic length	= 0 ft
Tc method	= TR55	Time of conc. (Tc)	= 8.30 min
Total precip.	= 6.28 in	Distribution	= Type II
Storm duration	= 24 hrs	Shape factor	= 484

* Composite (Area/CN) = [(5.550 x 86) + (9.740 x 91)] / 15.290

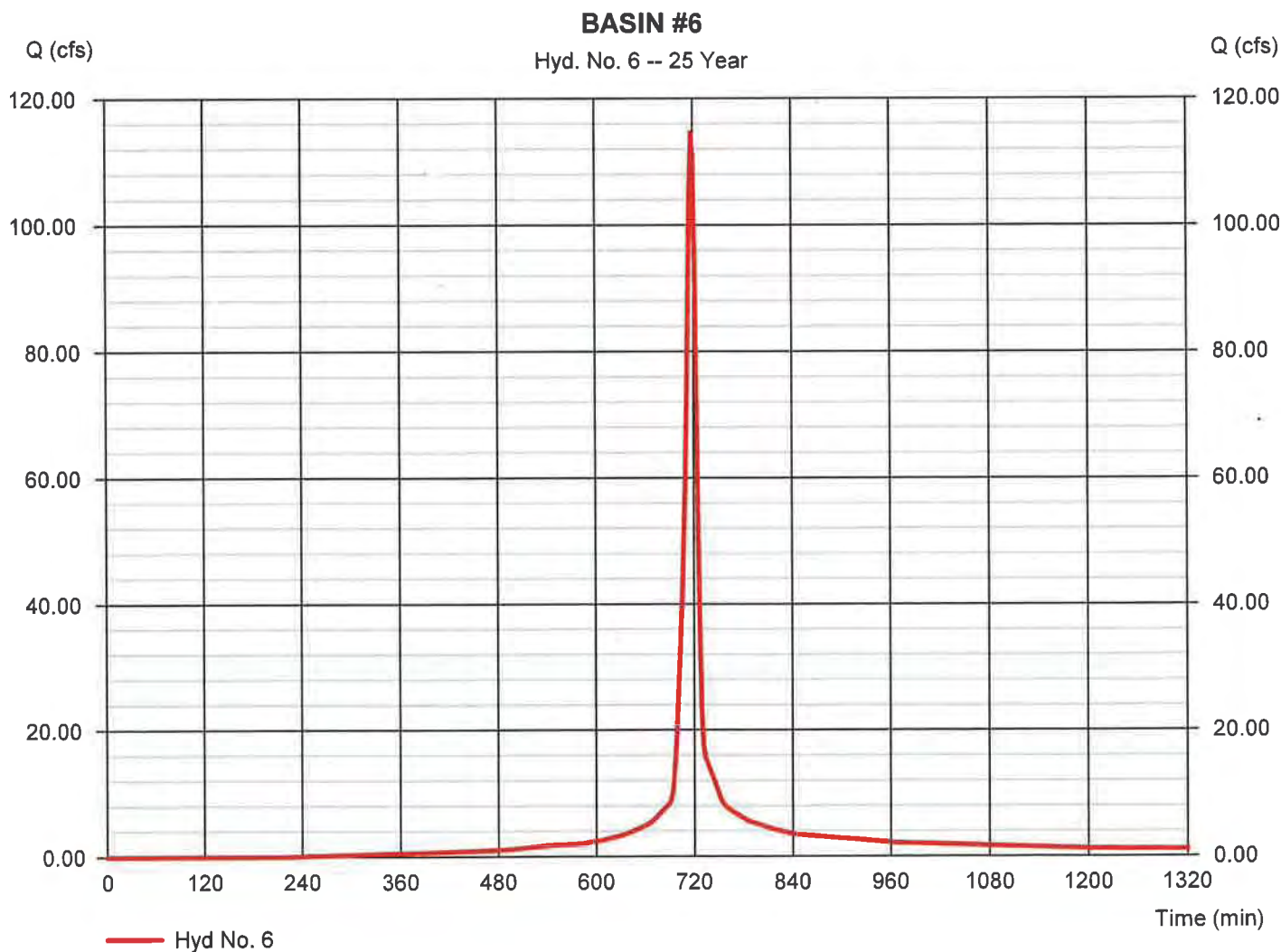

Hydrograph Report

Hyd. No. 7

BASIN #7

Hydrograph type	= SCS Runoff	Peak discharge	= 108.11 cfs
Storm frequency	= 25 yrs	Time to peak	= 718 min
Time interval	= 2 min	Hyd. volume	= 252,279 cuft
Drainage area	= 16.370 ac	Curve number	= 82*
Basin Slope	= 0.0 %	Hydraulic length	= 0 ft
Tc method	= TR55	Time of conc. (Tc)	= 7.40 min
Total precip.	= 6.28 in	Distribution	= Type II
Storm duration	= 24 hrs	Shape factor	= 484

* Composite (Area/CN) = [(7.330 x 86) + (5.180 x 91) + (3.330 x 61) + (0.530 x 74)] / 16.370

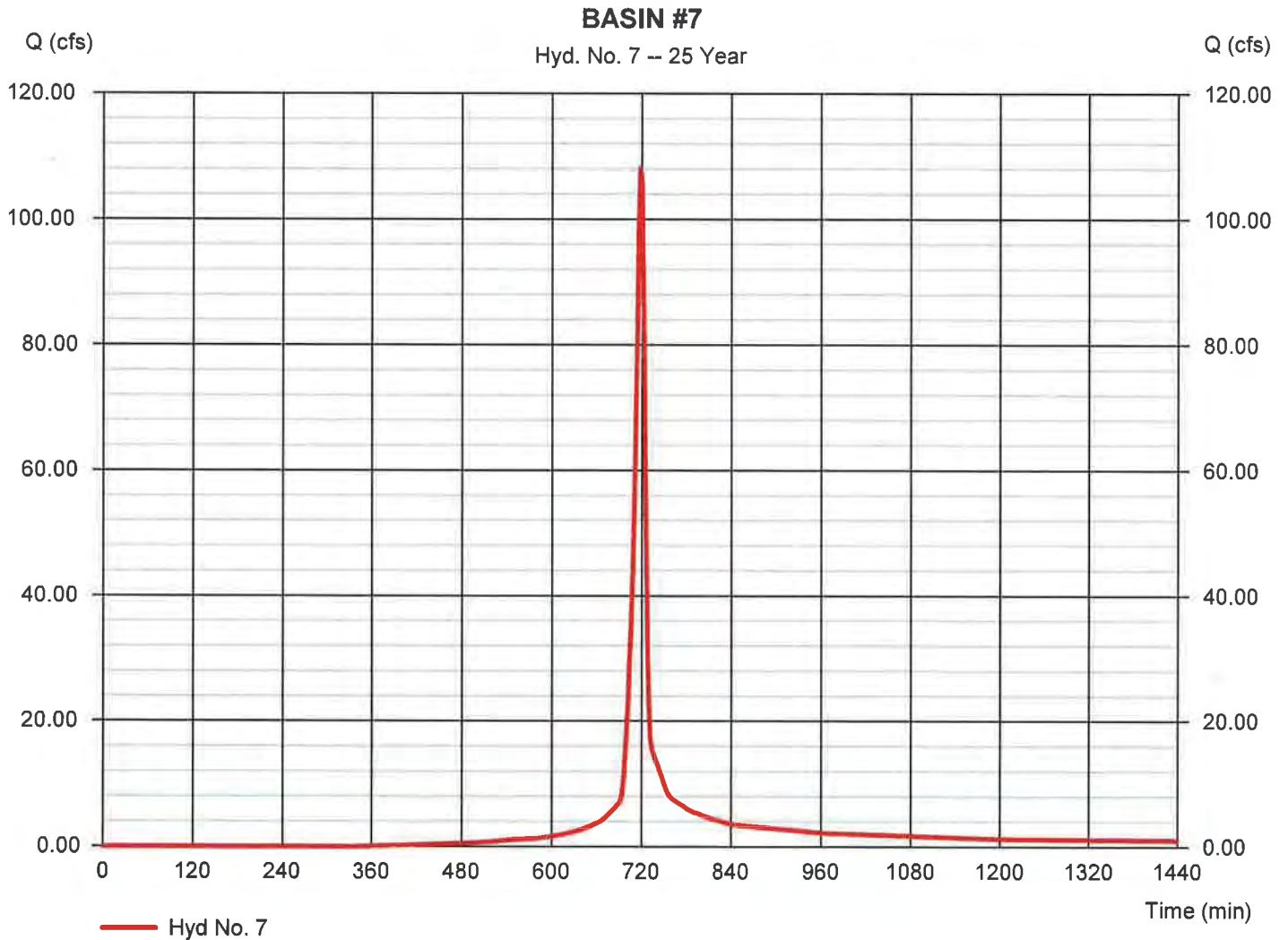

Hydrograph Report

Hydraflow Hydrographs Extension for AutoCAD® Civil 3D® 2014 by Autodesk, Inc. v10.3

Friday, 10 / 31 / 2014

Hyd. No. 8

BASIN #8

Hydrograph type	= SCS Runoff	Peak discharge	= 88.20 cfs
Storm frequency	= 25 yrs	Time to peak	= 716 min
Time interval	= 2 min	Hyd. volume	= 186,979 cuft
Drainage area	= 11.750 ac	Curve number	= 86*
Basin Slope	= 0.0 %	Hydraulic length	= 0 ft
Tc method	= User	Time of conc. (Tc)	= 5.00 min
Total precip.	= 6.28 in	Distribution	= Type II
Storm duration	= 24 hrs	Shape factor	= 484

* Composite (Area/CN) = [(11.750 x 86)] / 11.750

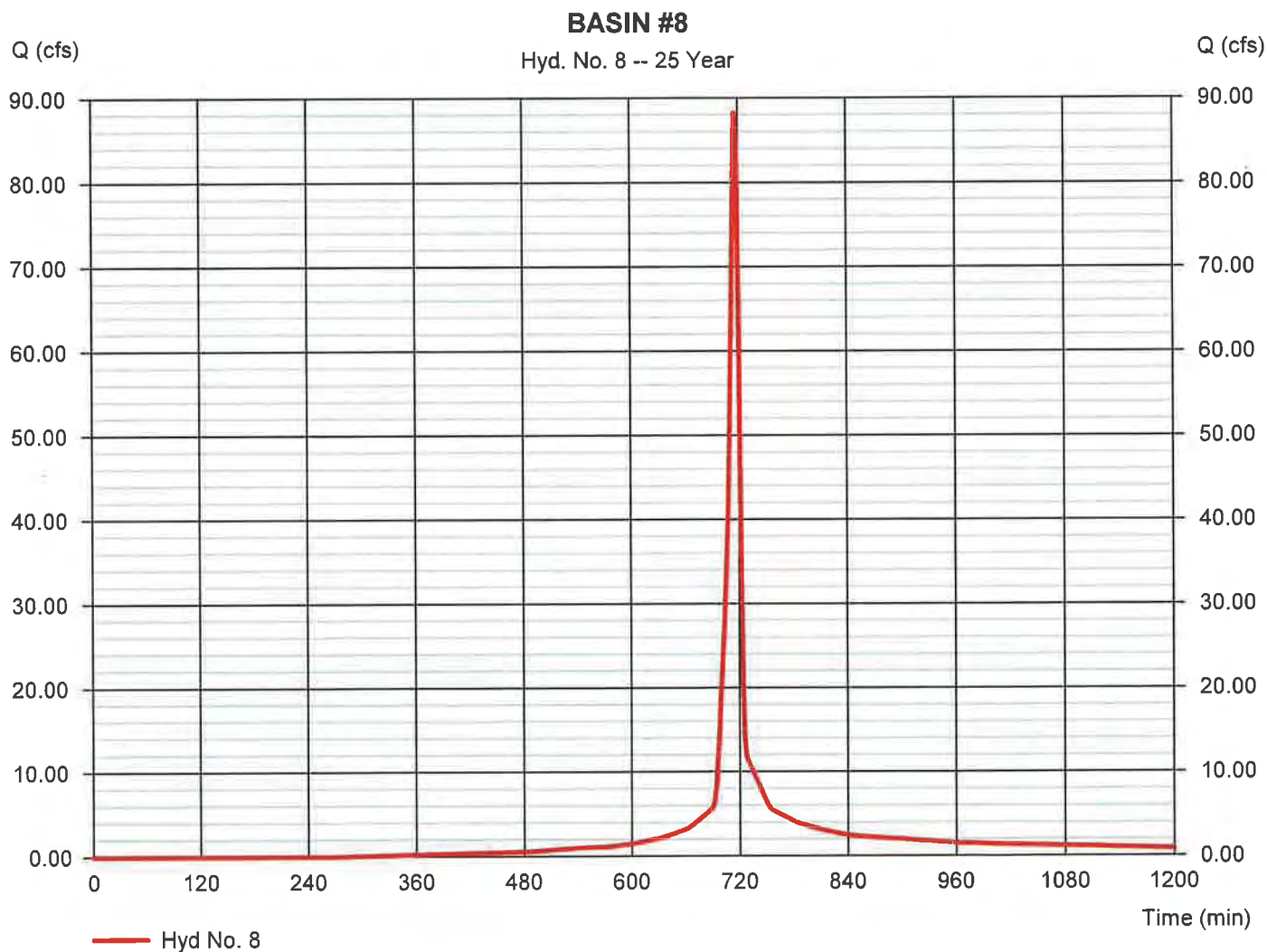

Hydrograph Report

Hyd. No. 9

BASIN #9

Hydrograph type	= SCS Runoff	Peak discharge	= 196.26 cfs
Storm frequency	= 25 yrs	Time to peak	= 728 min
Time interval	= 2 min	Hyd. volume	= 722,837 cuft
Drainage area	= 62.750 ac	Curve number	= 72*
Basin Slope	= 0.0 %	Hydraulic length	= 0 ft
Tc method	= TR55	Time of conc. (Tc)	= 26.80 min
Total precip.	= 6.28 in	Distribution	= Type II
Storm duration	= 24 hrs	Shape factor	= 484

* Composite (Area/CN) = [(32.830 x 86) + (16.030 x 55) + (9.190 x 91)] / 62.750

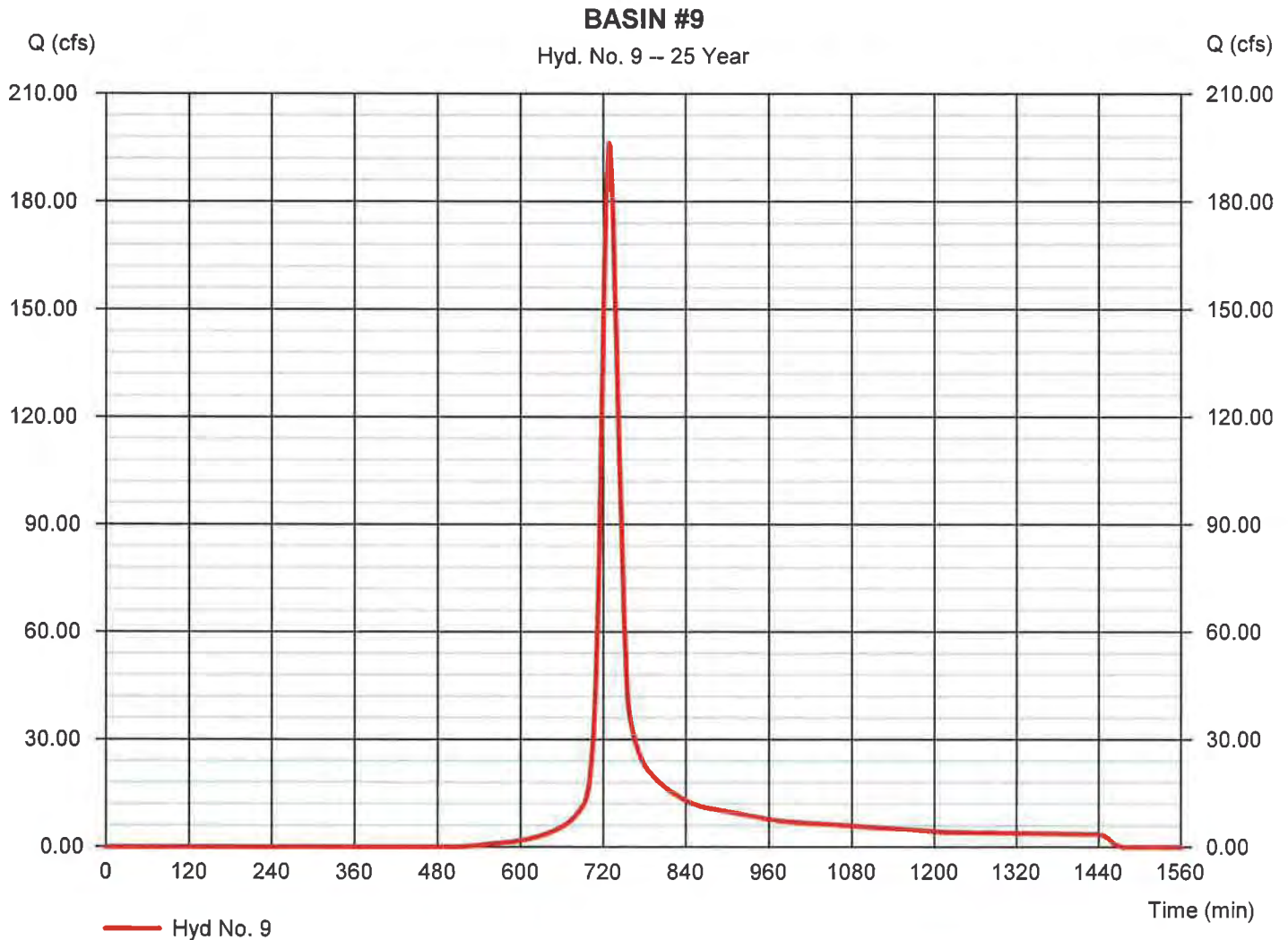

Hydrograph Summary Report

Hydraflow Hydrographs Extension for AutoCAD® Civil 3D® 2014 by Autodesk, Inc. v10.3

Hyd. No.	Hydrograph type (origin)	Peak flow (cfs)	Time interval (min)	Time to Peak (min)	Hyd. volume (cuft)	Inflow hyd(s)	Maximum elevation (ft)	Total strge used (cuft)	Hydrograph Description
1	SCS Runoff	53.13	2	716	114,638	---	---	---	BASIN #1
2	SCS Runoff	164.22	2	718	397,071	---	---	---	BASIN #2
3	SCS Runoff	31.93	2	716	71,569	---	---	---	BASIN #3
4	SCS Runoff	122.75	2	718	302,842	---	---	---	BASIN #4
5	SCS Runoff	476.49	2	718	1,175,598	---	---	---	BASIN #5
6	SCS Runoff	147.78	2	718	364,603	---	---	---	BASIN #6
7	SCS Runoff	144.24	2	718	341,440	---	---	---	BASIN #7
8	SCS Runoff	115.17	2	716	248,522	---	---	---	BASIN #8
9	SCS Runoff	280.49	2	728	1,029,030	---	---	---	BASIN #9
Basins-Phase 1.gpw					Return Period: 100 Year			Friday, 10 / 31 / 2014	

Hydrograph Report

Hyd. No. 1

BASIN #1

Hydrograph type	= SCS Runoff	Peak discharge	= 53.13 cfs
Storm frequency	= 100 yrs	Time to peak	= 716 min
Time interval	= 2 min	Hyd. volume	= 114,638 cuft
Drainage area	= 5.420 ac	Curve number	= 86*
Basin Slope	= 0.0 %	Hydraulic length	= 0 ft
Tc method	= TR55	Time of conc. (Tc)	= 5.50 min
Total precip.	= 7.88 in	Distribution	= Type II
Storm duration	= 24 hrs	Shape factor	= 484

* Composite (Area/CN) = [(5.420 x 86)] / 5.420

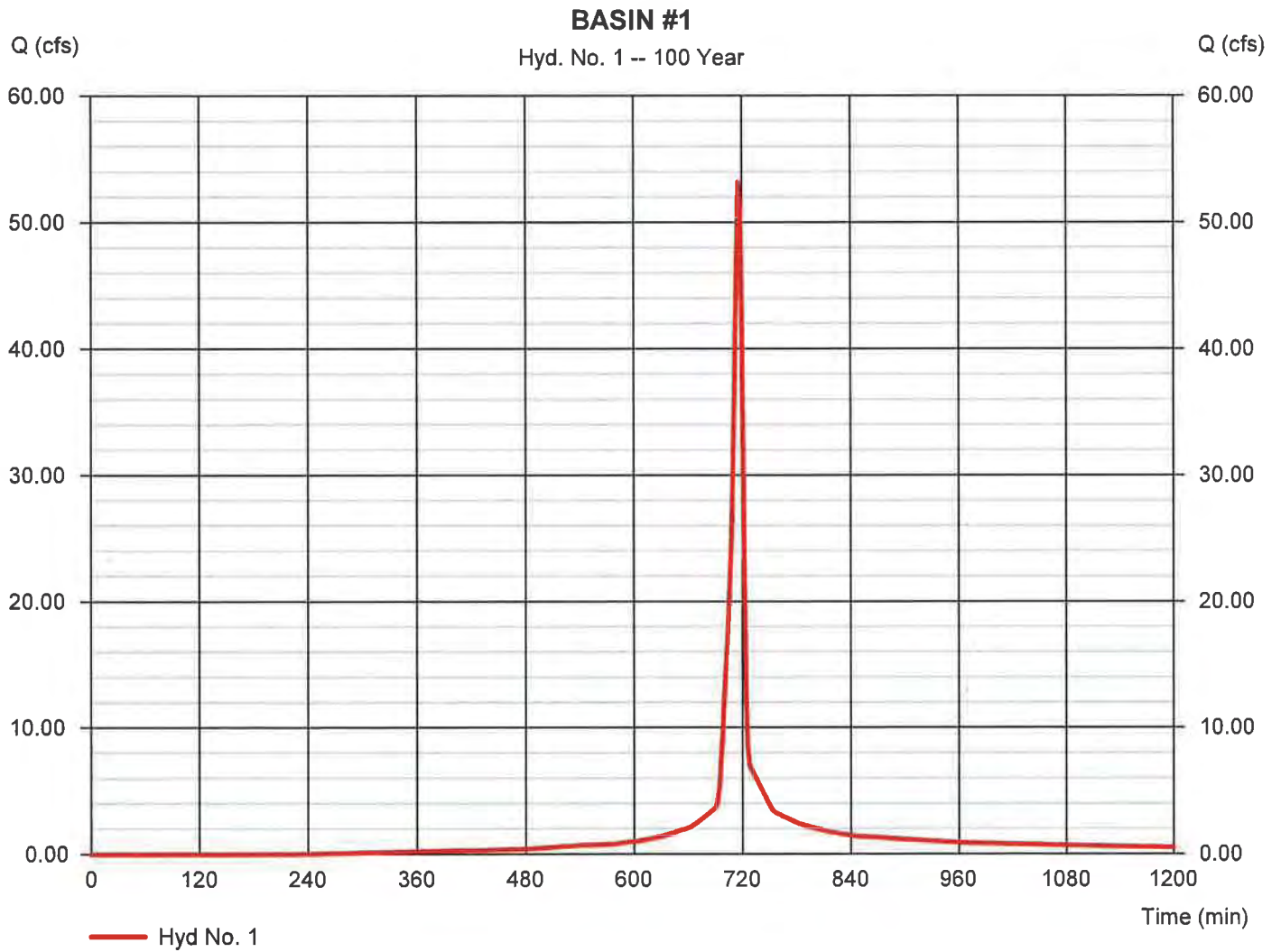

Hydrograph Report

Hydraflow Hydrographs Extension for AutoCAD® Civil 3D® 2014 by Autodesk, Inc. v10.3

Friday, 10 / 31 / 2014

Hyd. No. 2

BASIN #2

Hydrograph type	= SCS Runoff	Peak discharge	= 164.22 cfs
Storm frequency	= 100 yrs	Time to peak	= 718 min
Time interval	= 2 min	Hyd. volume	= 397,071 cuft
Drainage area	= 17.600 ac	Curve number	= 86*
Basin Slope	= 0.0 %	Hydraulic length	= 0 ft
Tc method	= TR55	Time of conc. (Tc)	= 7.90 min
Total precip.	= 7.88 in	Distribution	= Type II
Storm duration	= 24 hrs	Shape factor	= 484

* Composite (Area/CN) = [(17.600 x 86)] / 17.600

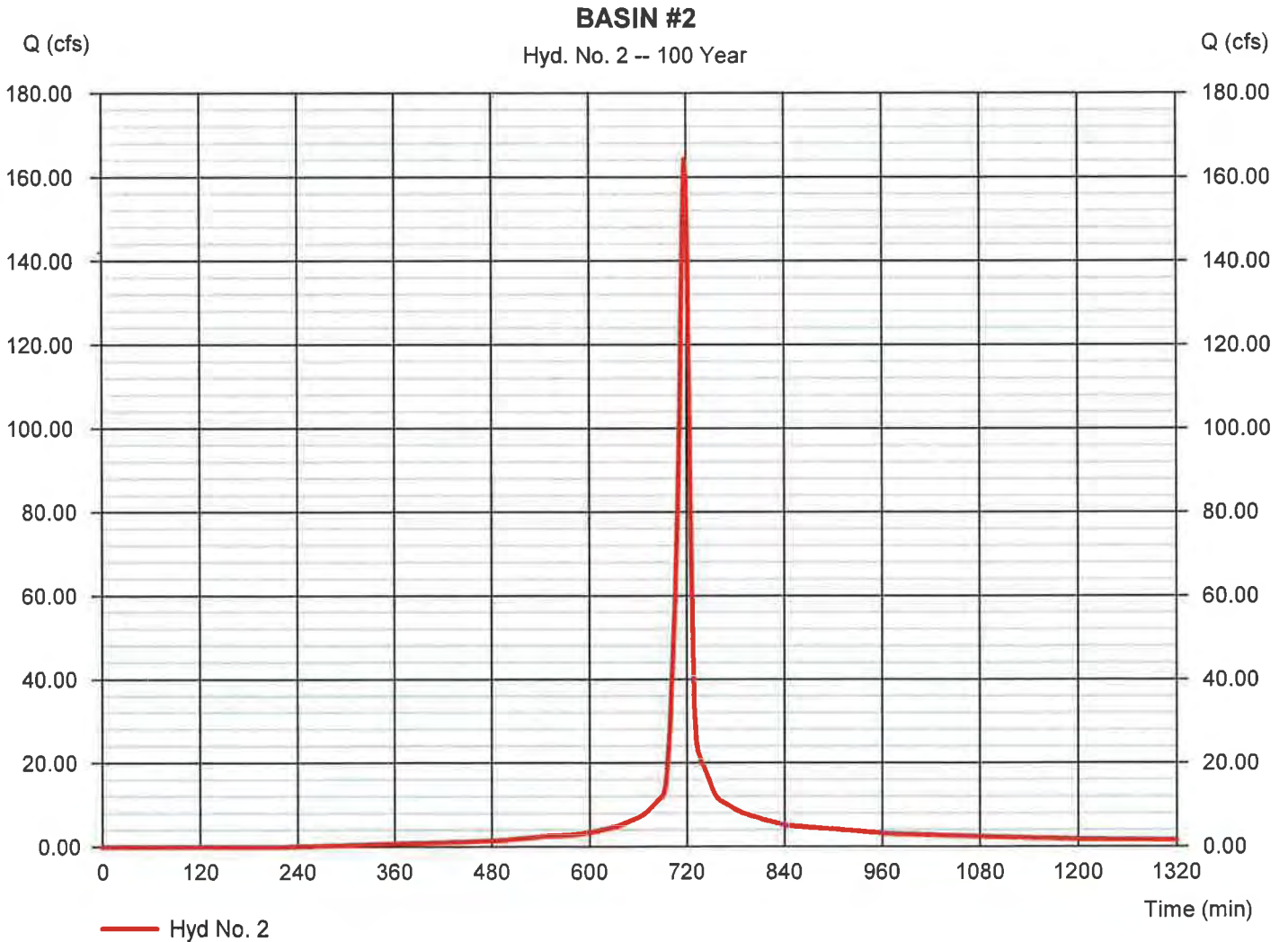

Hydrograph Report

Hyd. No. 3

BASIN #3

Hydrograph type	= SCS Runoff	Peak discharge	= 31.93 cfs
Storm frequency	= 100 yrs	Time to peak	= 716 min
Time interval	= 2 min	Hyd. volume	= 71,569 cuft
Drainage area	= 3.090 ac	Curve number	= 91*
Basin Slope	= 0.0 %	Hydraulic length	= 0 ft
Tc method	= User	Time of conc. (Tc)	= 5.00 min
Total precip.	= 7.88 in	Distribution	= Type II
Storm duration	= 24 hrs	Shape factor	= 484

* Composite (Area/CN) = [(3.090 x 91)] / 3.090

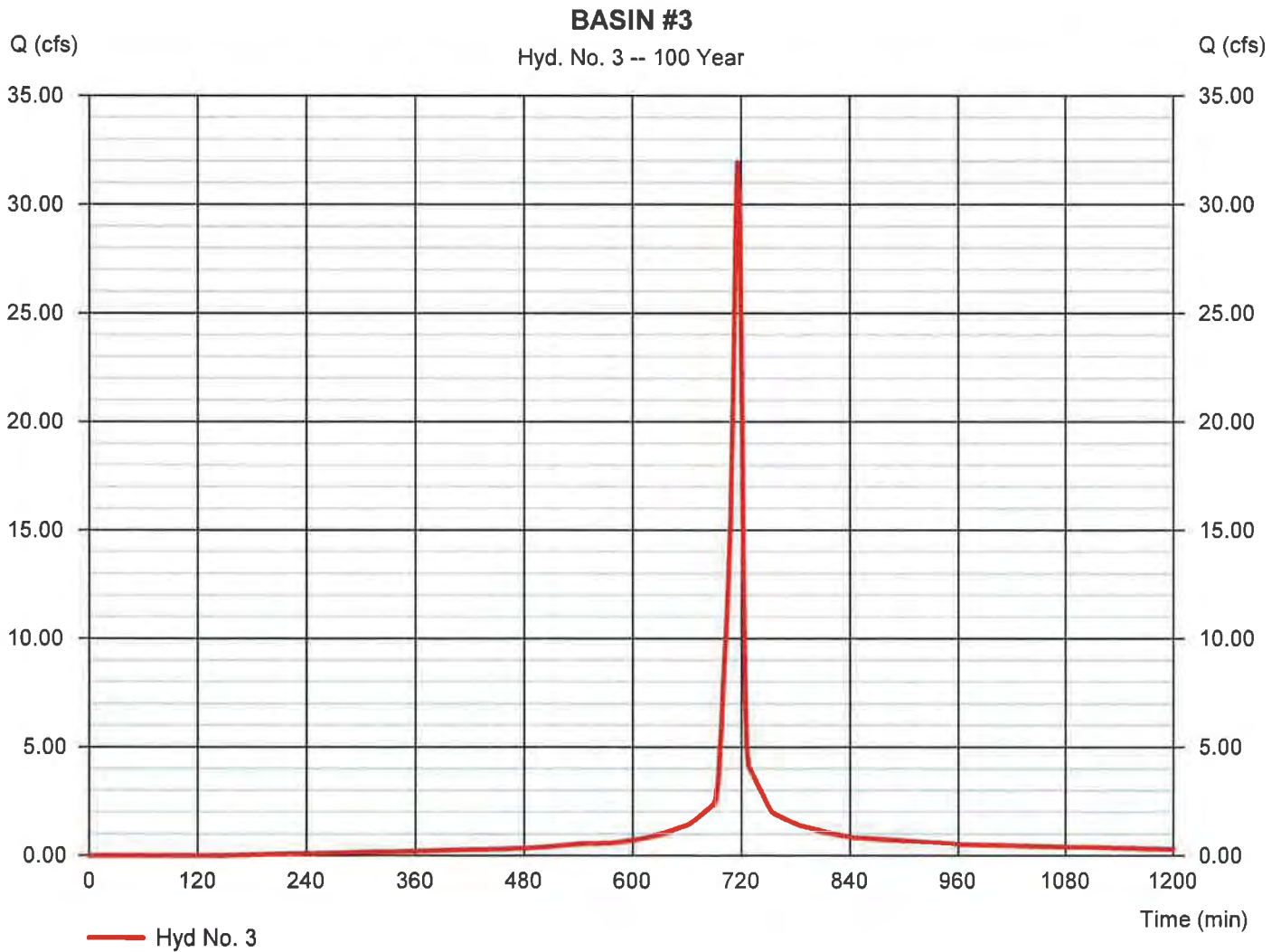

Hydrograph Report

Hydraflow Hydrographs Extension for AutoCAD® Civil 3D® 2014 by Autodesk, Inc. v10.3

Friday, 10 / 31 / 2014

Hyd. No. 4

BASIN #4

Hydrograph type	= SCS Runoff	Peak discharge	= 122.75 cfs
Storm frequency	= 100 yrs	Time to peak	= 718 min
Time interval	= 2 min	Hyd. volume	= 302,842 cuft
Drainage area	= 12.700 ac	Curve number	= 89*
Basin Slope	= 0.0 %	Hydraulic length	= 0 ft
Tc method	= TR55	Time of conc. (Tc)	= 8.60 min
Total precip.	= 7.88 in	Distribution	= Type II
Storm duration	= 24 hrs	Shape factor	= 484

* Composite (Area/CN) = [(5.880 x 86) + (6.820 x 91)] / 12.700

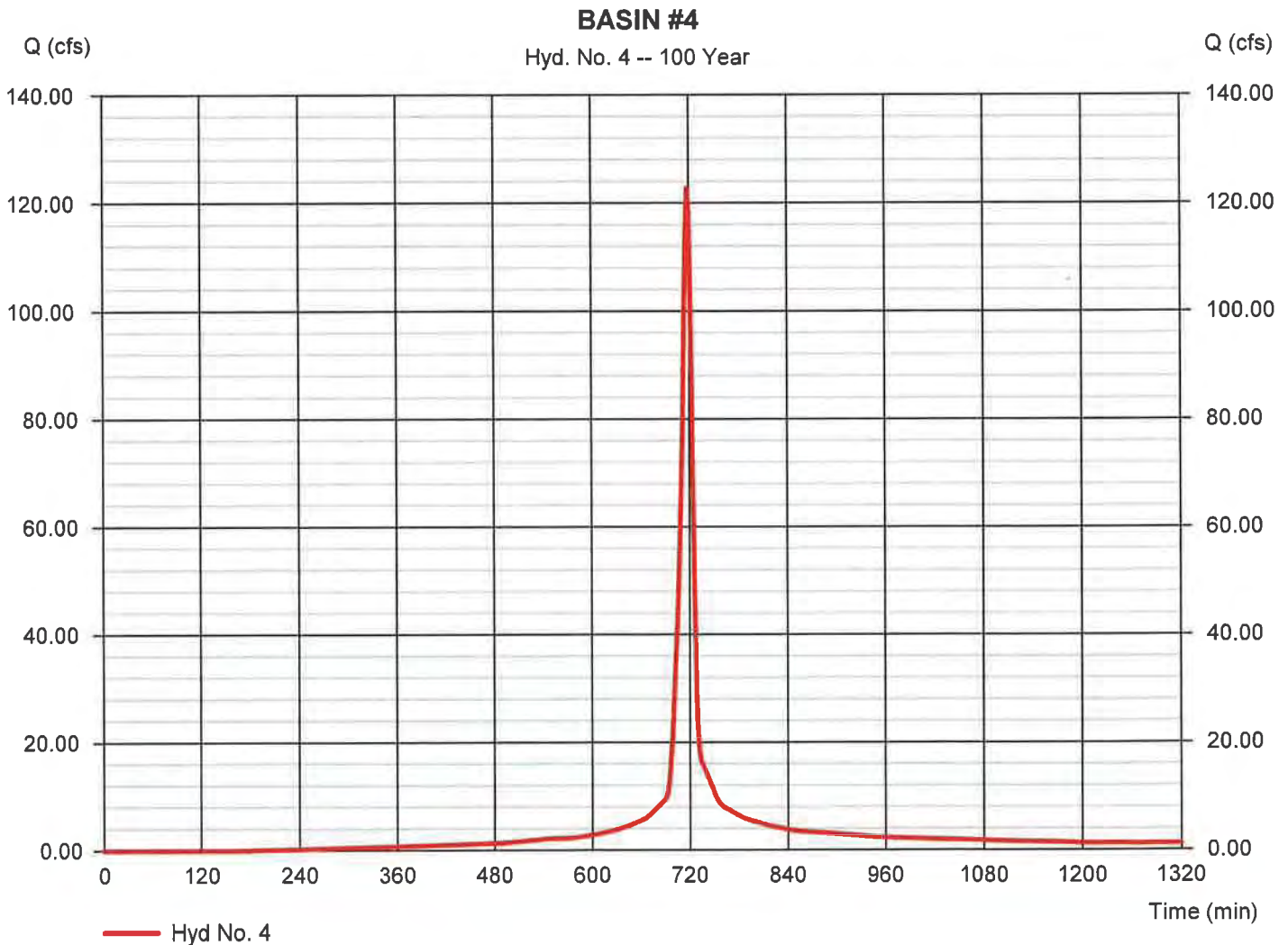

Hyd. No. 5

BASIN #5

Hydrograph type	= SCS Runoff	Peak discharge	= 476.49 cfs
Storm frequency	= 100 yrs	Time to peak	= 718 min
Time interval	= 2 min	Hyd. volume	= 1,175,598 cuft
Drainage area	= 49.300 ac	Curve number	= 89*
Basin Slope	= 0.0 %	Hydraulic length	= 0 ft
Tc method	= TR55	Time of conc. (Tc)	= 9.50 min
Total precip.	= 7.88 in	Distribution	= Type II
Storm duration	= 24 hrs	Shape factor	= 484

* Composite (Area/CN) = [(24.900 x 86) + (21.230 x 91) + (3.170 x 94)] / 49.300

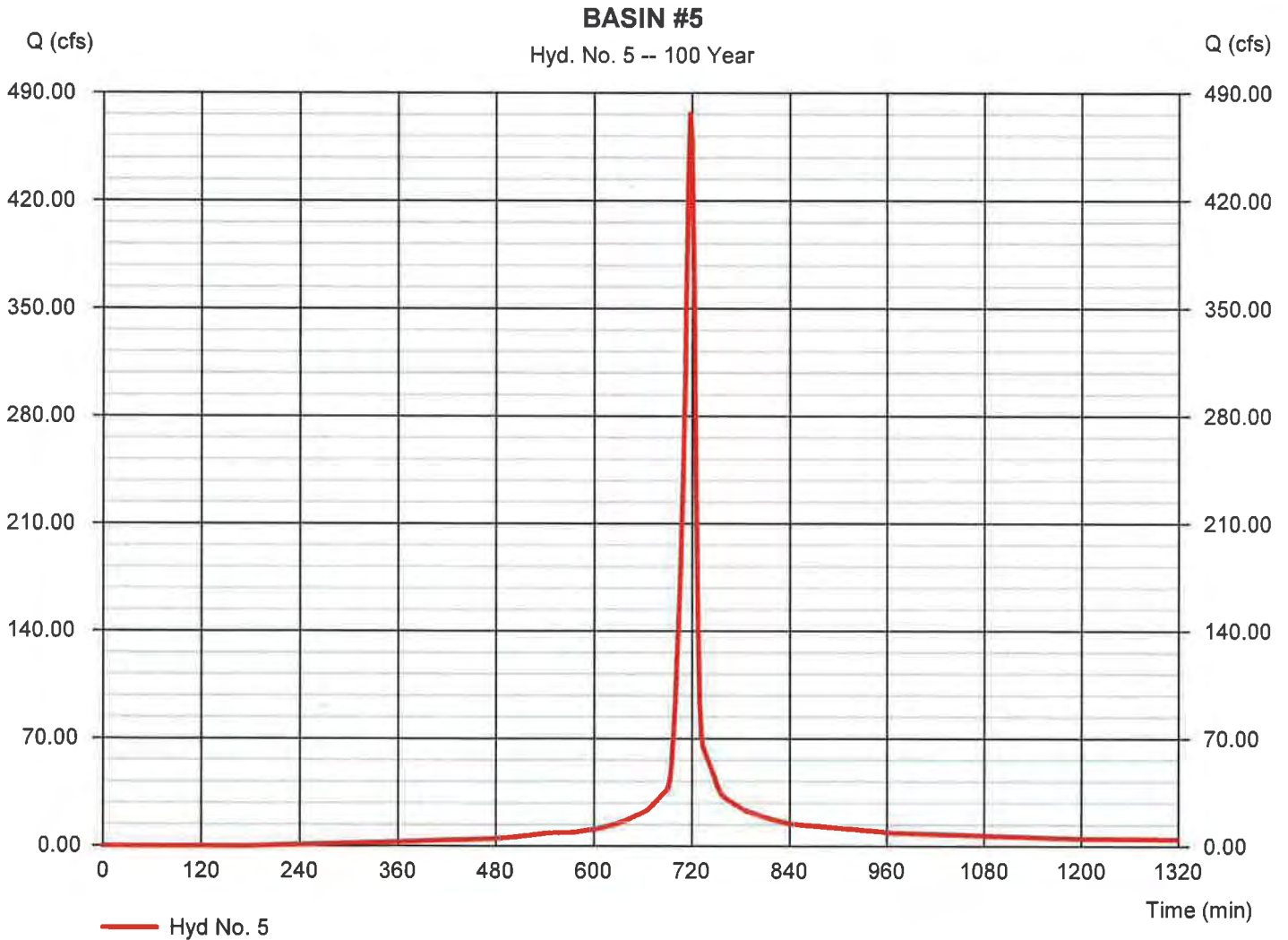

Hydrograph Report

Hydraflow Hydrographs Extension for AutoCAD® Civil 3D® 2014 by Autodesk, Inc. v10.3

Friday, 10 / 31 / 2014

Hyd. No. 6

BASIN #6

Hydrograph type	= SCS Runoff	Peak discharge	= 147.78 cfs
Storm frequency	= 100 yrs	Time to peak	= 718 min
Time interval	= 2 min	Hyd. volume	= 364,603 cuft
Drainage area	= 15.290 ac	Curve number	= 89*
Basin Slope	= 0.0 %	Hydraulic length	= 0 ft
Tc method	= TR55	Time of conc. (Tc)	= 8.30 min
Total precip.	= 7.88 in	Distribution	= Type II
Storm duration	= 24 hrs	Shape factor	= 484

* Composite (Area/CN) = [(5.550 x 86) + (9.740 x 91)] / 15.290

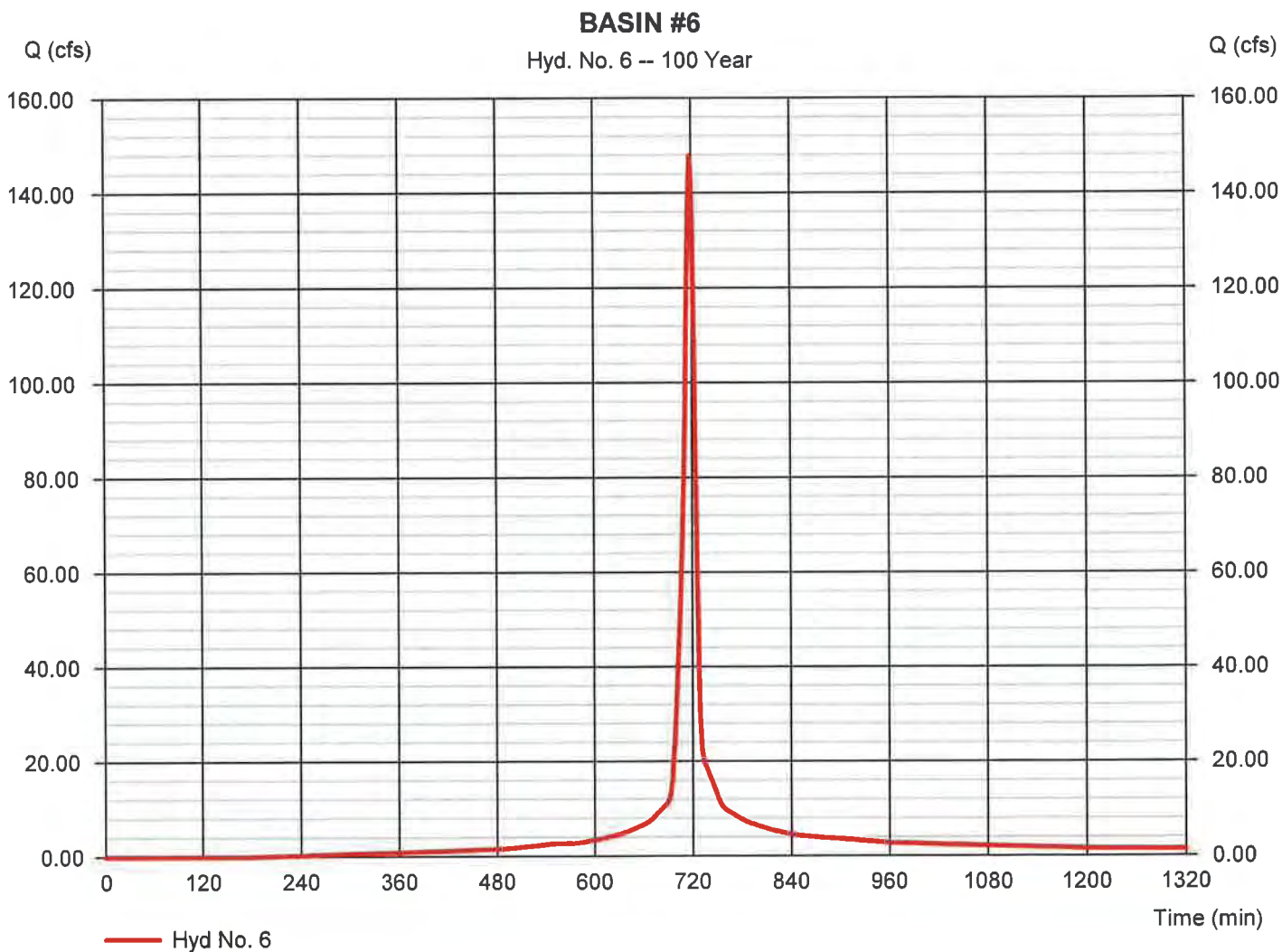

Hydrograph Report

Hyd. No. 7

BASIN #7

Hydrograph type	= SCS Runoff	Peak discharge	= 144.24 cfs
Storm frequency	= 100 yrs	Time to peak	= 718 min
Time interval	= 2 min	Hyd. volume	= 341,440 cuft
Drainage area	= 16.370 ac	Curve number	= 82*
Basin Slope	= 0.0 %	Hydraulic length	= 0 ft
Tc method	= TR55	Time of conc. (Tc)	= 7.40 min
Total precip.	= 7.88 in	Distribution	= Type II
Storm duration	= 24 hrs	Shape factor	= 484

* Composite (Area/CN) = [(7.330 x 86) + (5.180 x 91) + (3.330 x 61) + (0.530 x 74)] / 16.370

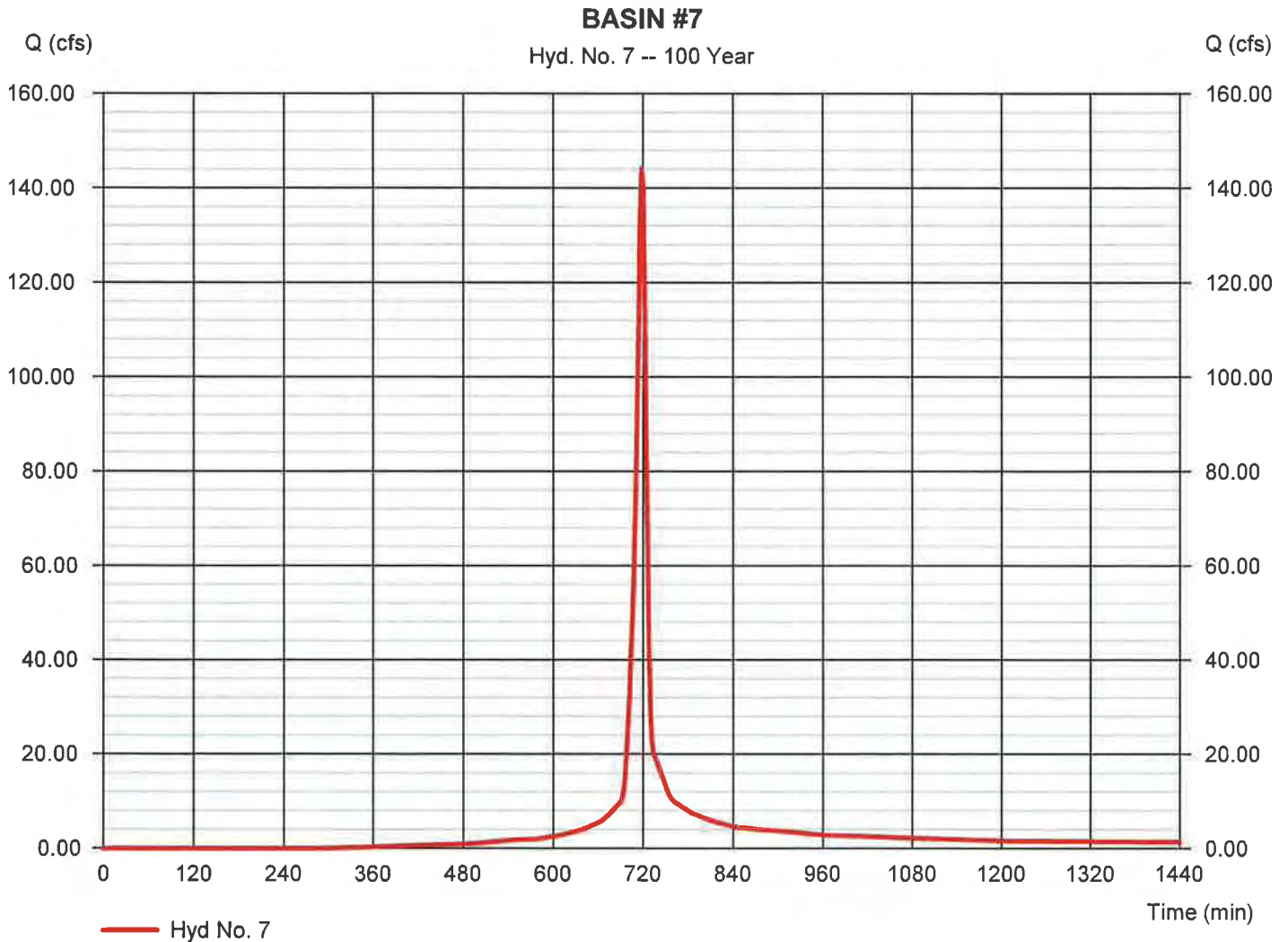

Hydrograph Report

Hydraflow Hydrographs Extension for AutoCAD® Civil 3D® 2014 by Autodesk, Inc. v10.3

Friday, 10 / 31 / 2014

Hyd. No. 8

BASIN #8

Hydrograph type	= SCS Runoff	Peak discharge	= 115.17 cfs
Storm frequency	= 100 yrs	Time to peak	= 716 min
Time interval	= 2 min	Hyd. volume	= 248,522 cuft
Drainage area	= 11.750 ac	Curve number	= 86*
Basin Slope	= 0.0 %	Hydraulic length	= 0 ft
Tc method	= User	Time of conc. (Tc)	= 5.00 min
Total precip.	= 7.88 in	Distribution	= Type II
Storm duration	= 24 hrs	Shape factor	= 484

* Composite (Area/CN) = [(11.750 x 86)] / 11.750

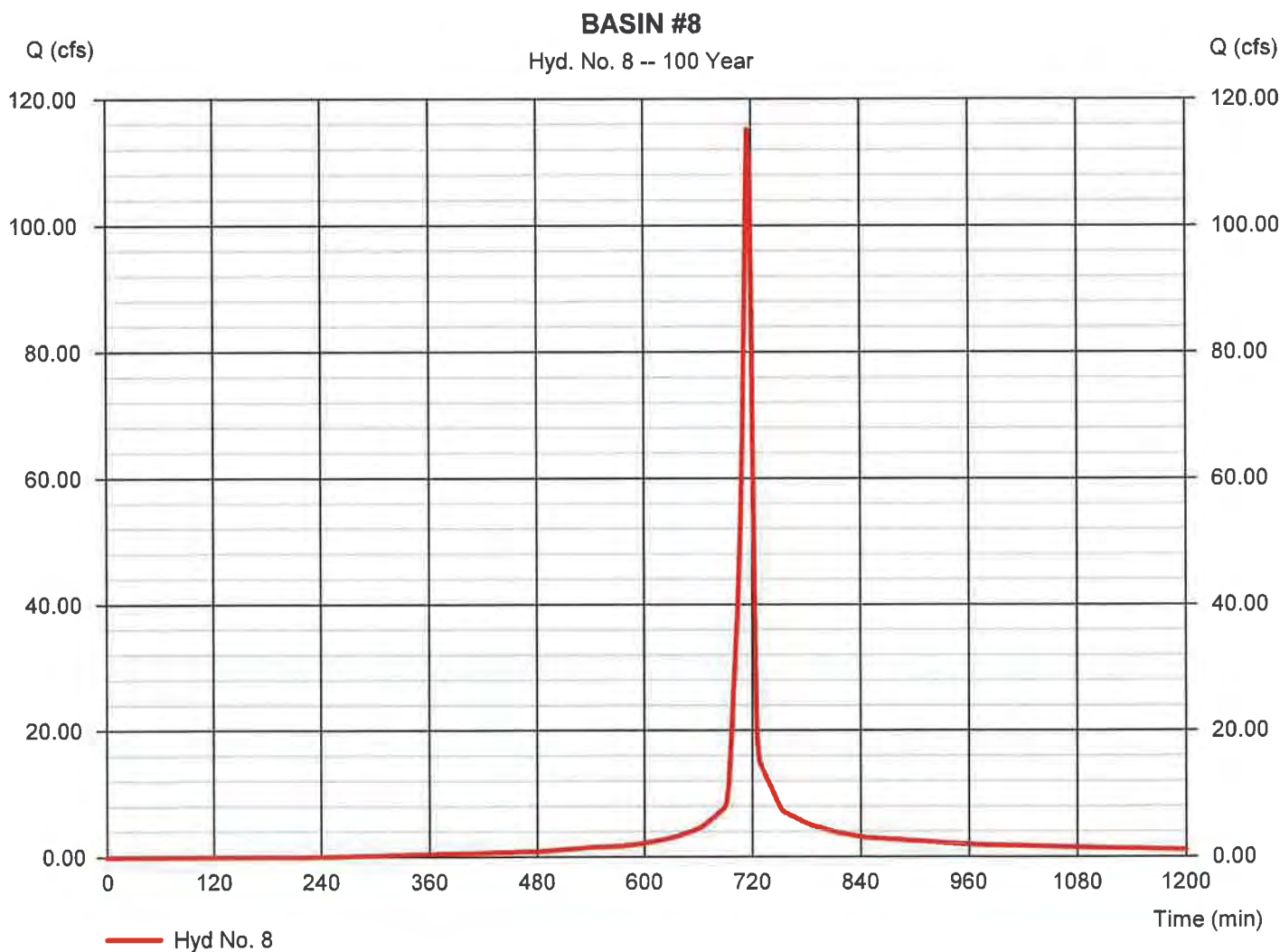

Hydrograph Report

Hyd. No. 9

BASIN #9

Hydrograph type	= SCS Runoff	Peak discharge	= 280.49 cfs
Storm frequency	= 100 yrs	Time to peak	= 728 min
Time interval	= 2 min	Hyd. volume	= 1,029,030 cuft
Drainage area	= 62.750 ac	Curve number	= 72*
Basin Slope	= 0.0 %	Hydraulic length	= 0 ft
Tc method	= TR55	Time of conc. (Tc)	= 26.80 min
Total precip.	= 7.88 in	Distribution	= Type II
Storm duration	= 24 hrs	Shape factor	= 484

* Composite (Area/CN) = [(32.830 x 86) + (16.030 x 55) + (9.190 x 91)] / 62.750

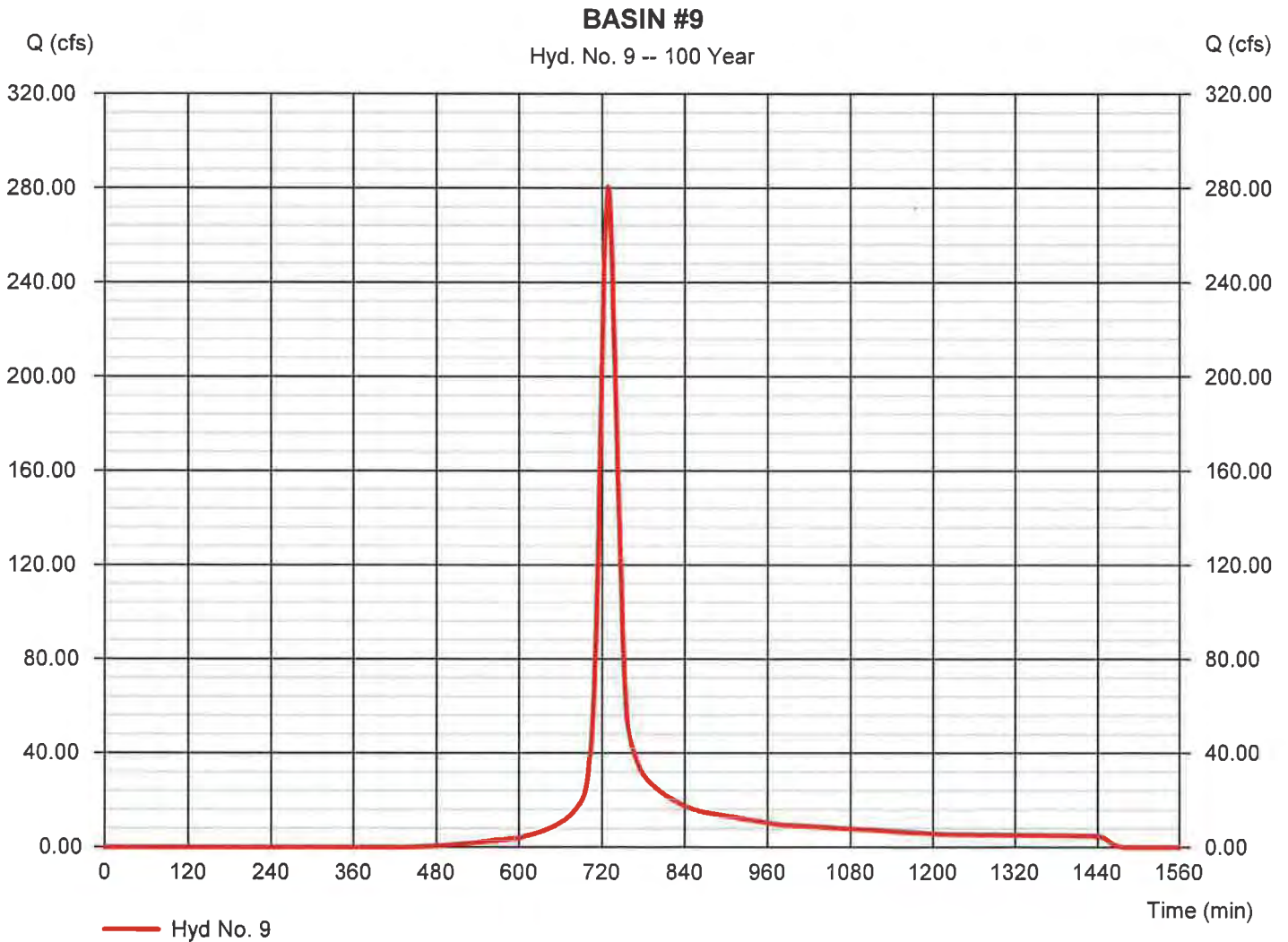

This page intentionally left blank.

Hydrograph Summary Report

Hydraflow Hydrographs Extension for AutoCAD® Civil 3D® 2014 by Autodesk, Inc. v10.3

Hyd. No.	Hydrograph type (origin)	Peak flow (cfs)	Time interval (min)	Time to Peak (min)	Hyd. volume (cuft)	Inflow hyd(s)	Maximum elevation (ft)	Total strge used (cuft)	Hydrograph Description	
1	SCS Runoff	252.52	2	718	600,865	---	---	---	BASIN #5	
2	SCS Runoff	43.09	2	722	123,140	---	---	---	BASIN #1	
3	SCS Runoff	79.90	2	720	212,575	---	---	---	BASIN #2	
4	SCS Runoff	134.71	2	722	378,978	---	---	---	BASIN #7	
5	SCS Runoff	199.50	2	728	741,644	---	---	---	BASIN #9	
Basins-Phase 2.gpw					Return Period: 10 Year			Friday, 10 / 31 / 2014		

Hydrograph Report

Hydraflow Hydrographs Extension for AutoCAD® Civil 3D® 2014 by Autodesk, Inc. v10.3

Friday, 10 / 31 / 2014

Hyd. No. 1

BASIN #5

Hydrograph type	= SCS Runoff	Peak discharge	= 252.52 cfs
Storm frequency	= 10 yrs	Time to peak	= 718 min
Time interval	= 2 min	Hyd. volume	= 600,865 cuft
Drainage area	= 42.060 ac	Curve number	= 88*
Basin Slope	= 0.0 %	Hydraulic length	= 0 ft
Tc method	= TR55	Time of conc. (Tc)	= 9.50 min
Total precip.	= 5.28 in	Distribution	= Type II
Storm duration	= 24 hrs	Shape factor	= 484

* Composite (Area/CN) = [(35.010 x 86) + (3.880 x 91) + (3.170 x 94)] / 42.060

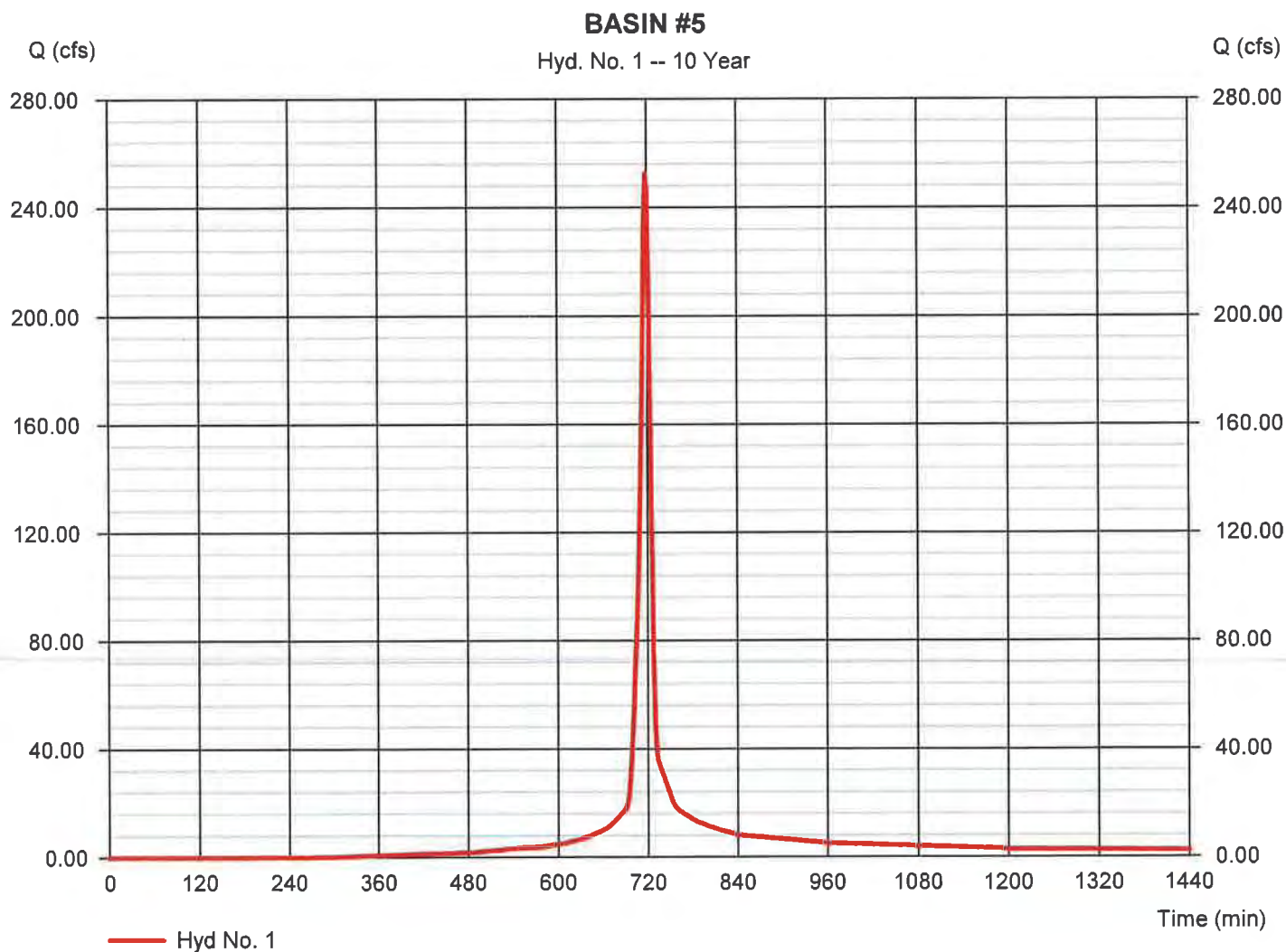

TR55 Tc Worksheet

Hyd. No. 1

BASIN #5

<u>Description</u>	<u>A</u>	<u>B</u>	<u>C</u>	<u>Totals</u>
Sheet Flow				
Manning's n-value	= 0.050	0.011	0.011	
Flow length (ft)	= 100.0	0.0	0.0	
Two-year 24-hr precip. (in)	= 3.62	0.00	0.00	
Land slope (%)	= 2.00	0.00	0.00	
Travel Time (min)	= 3.83	+ 0.00	+ 0.00	= 3.83
Shallow Concentrated Flow				
Flow length (ft)	= 316.00	0.00	0.00	
Watercourse slope (%)	= 8.90	0.00	0.00	
Surface description	= Unpaved	Paved	Paved	
Average velocity (ft/s)	=4.81	0.00	0.00	
Travel Time (min)	= 1.09	+ 0.00	+ 0.00	= 1.09
Channel Flow				
X sectional flow area (sqft)	= 20.00	0.00	0.00	
Wetted perimeter (ft)	= 14.00	0.00	0.00	
Channel slope (%)	= 2.30	0.00	0.00	
Manning's n-value	= 0.050	0.015	0.015	
Velocity (ft/s)	=5.74	0.00	0.00	
Flow length (ft)	{{0}}1588.0	0.0	0.0	
Travel Time (min)	= 4.61	+ 0.00	+ 0.00	= 4.61
Total Travel Time, Tc				9.50 min

Hydrograph Report

Hydraflow Hydrographs Extension for AutoCAD® Civil 3D® 2014 by Autodesk, Inc. v10.3

Friday, 10 / 31 / 2014

Hyd. No. 2

BASIN #1

Hydrograph type	= SCS Runoff	Peak discharge	= 43.09 cfs
Storm frequency	= 10 yrs	Time to peak	= 722 min
Time interval	= 2 min	Hyd. volume	= 123,140 cuft
Drainage area	= 9.330 ac	Curve number	= 86*
Basin Slope	= 0.0 %	Hydraulic length	= 0 ft
Tc method	= TR55	Time of conc. (Tc)	= 13.80 min
Total precip.	= 5.28 in	Distribution	= Type II
Storm duration	= 24 hrs	Shape factor	= 484

* Composite (Area/CN) = [(9.330 x 86)] / 9.330

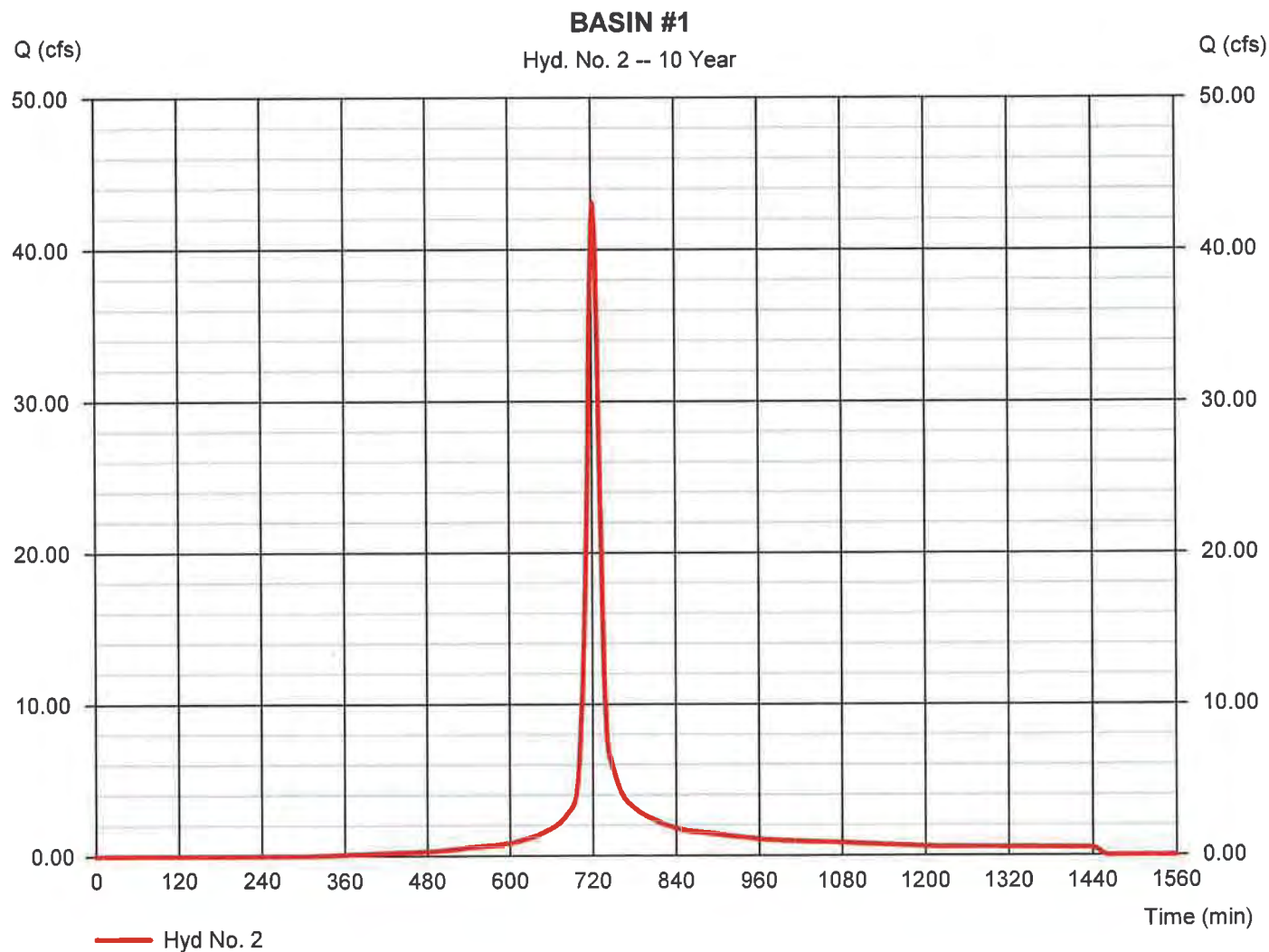

TR55 Tc Worksheet

Hyd. No. 2

BASIN #1

<u>Description</u>	<u>A</u>	<u>B</u>	<u>C</u>	<u>Totals</u>
Sheet Flow				
Manning's n-value	= 0.050	0.011	0.011	
Flow length (ft)	= 200.0	0.0	0.0	
Two-year 24-hr precip. (in)	= 3.62	0.00	0.00	
Land slope (%)	= 1.00	0.00	0.00	
Travel Time (min)	= 8.79	+ 0.00	+ 0.00	= 8.79
Shallow Concentrated Flow				
Flow length (ft)	= 400.00	0.00	0.00	
Watercourse slope (%)	= 1.00	0.00	0.00	
Surface description	= Unpaved	Paved	Paved	
Average velocity (ft/s)	=1.61	0.00	0.00	
Travel Time (min)	= 4.13	+ 0.00	+ 0.00	= 4.13
Channel Flow				
X sectional flow area (sqft)	= 20.00	0.00	0.00	
Wetted perimeter (ft)	= 14.00	0.00	0.00	
Channel slope (%)	= 7.00	0.00	0.00	
Manning's n-value	= 0.050	0.015	0.015	
Velocity (ft/s)	=10.01	0.00	0.00	
Flow length (ft)	{{0}}526.0	0.0	0.0	
Travel Time (min)	= 0.88	+ 0.00	+ 0.00	= 0.88
Total Travel Time, Tc				13.80 min

Hydrograph Report

Hydraflow Hydrographs Extension for AutoCAD® Civil 3D® 2014 by Autodesk, Inc. v10.3

Friday, 10 / 31 / 2014

Hyd. No. 3

BASIN #2

Hydrograph type	= SCS Runoff	Peak discharge	= 79.90 cfs
Storm frequency	= 10 yrs	Time to peak	= 720 min
Time interval	= 2 min	Hyd. volume	= 212,575 cuft
Drainage area	= 14.820 ac	Curve number	= 87*
Basin Slope	= 0.0 %	Hydraulic length	= 0 ft
Tc method	= TR55	Time of conc. (Tc)	= 13.30 min
Total precip.	= 5.28 in	Distribution	= Type II
Storm duration	= 24 hrs	Shape factor	= 484

* Composite (Area/CN) = $[(11.890 \times 86) + (2.930 \times 91)] / 14.820$

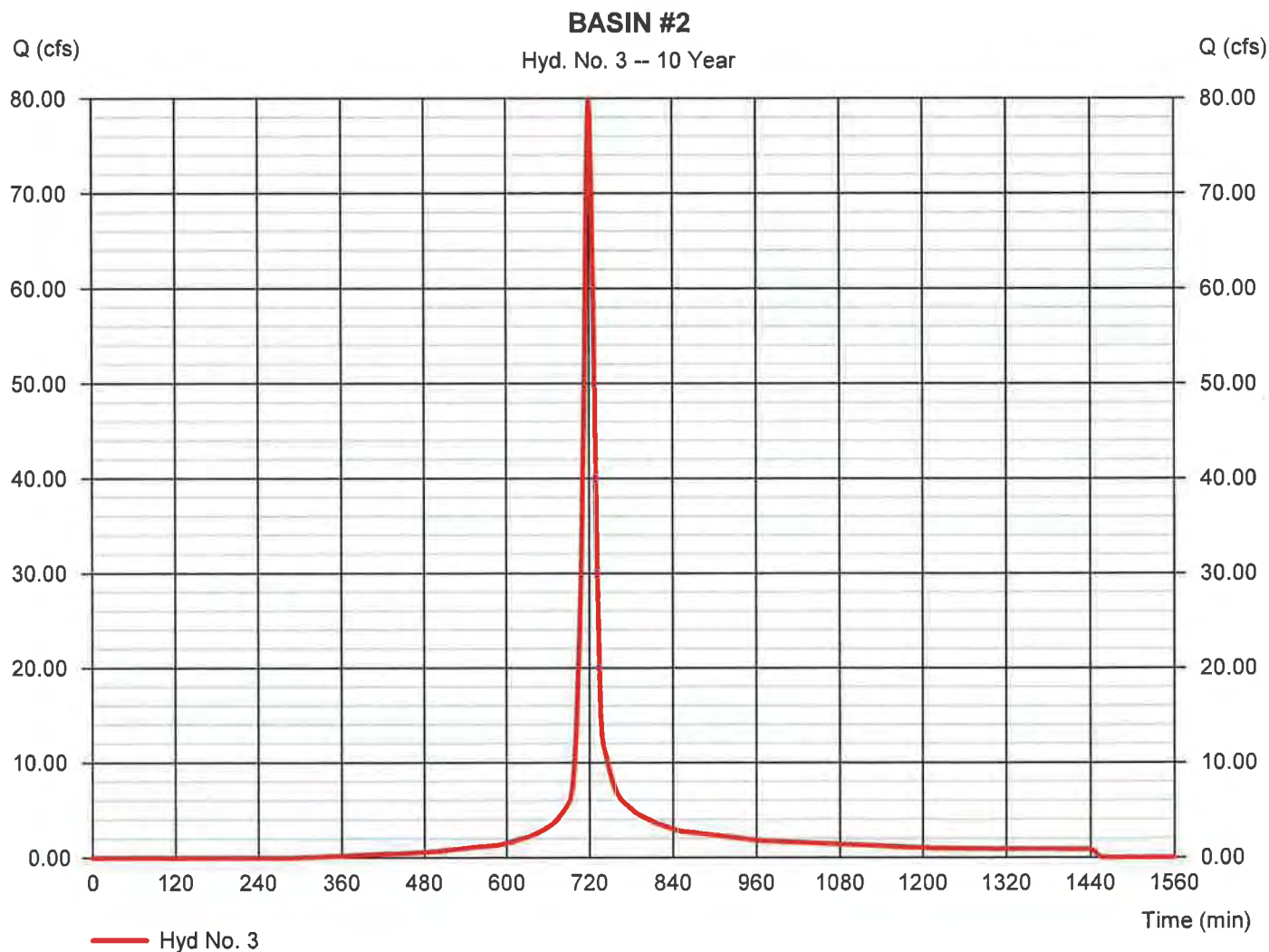

TR55 Tc Worksheet

Hyd. No. 3

BASIN #2

<u>Description</u>	<u>A</u>	<u>B</u>	<u>C</u>	<u>Totals</u>
Sheet Flow				
Manning's n-value	= 0.050	0.011	0.011	
Flow length (ft)	= 200.0	0.0	0.0	
Two-year 24-hr precip. (in)	= 3.62	0.00	0.00	
Land slope (%)	= 1.00	0.00	0.00	
Travel Time (min)	= 8.79	+ 0.00	+ 0.00	= 8.79
Shallow Concentrated Flow				
Flow length (ft)	= 594.00	0.00	0.00	
Watercourse slope (%)	= 6.40	0.00	0.00	
Surface description	= Unpaved	Paved	Paved	
Average velocity (ft/s)	=4.08	0.00	0.00	
Travel Time (min)	= 2.43	+ 0.00	+ 0.00	= 2.43
Channel Flow				
X sectional flow area (sqft)	= 10.00	0.00	0.00	
Wetted perimeter (ft)	= 9.00	0.00	0.00	
Channel slope (%)	= 3.50	0.00	0.00	
Manning's n-value	= 0.050	0.015	0.015	
Velocity (ft/s)	=5.98	0.00	0.00	
Flow length (ft)	{{0}}739.0	0.0	0.0	
Travel Time (min)	= 2.06	+ 0.00	+ 0.00	= 2.06
Total Travel Time, Tc				13.30 min

Hydrograph Report

Hydraflow Hydrographs Extension for AutoCAD® Civil 3D® 2014 by Autodesk, Inc. v10.3

Friday, 10 / 31 / 2014

Hyd. No. 4

BASIN #7

Hydrograph type	= SCS Runoff	Peak discharge	= 134.71 cfs
Storm frequency	= 10 yrs	Time to peak	= 722 min
Time interval	= 2 min	Hyd. volume	= 378,978 cuft
Drainage area	= 33.110 ac	Curve number	= 81*
Basin Slope	= 0.0 %	Hydraulic length	= 0 ft
Tc method	= TR55	Time of conc. (Tc)	= 15.30 min
Total precip.	= 5.28 in	Distribution	= Type II
Storm duration	= 24 hrs	Shape factor	= 484

* Composite (Area/CN) = [(26.860 x 86) + (2.390 x 91) + (0.530 x 61) + (3.330 x 74)] / 33.110

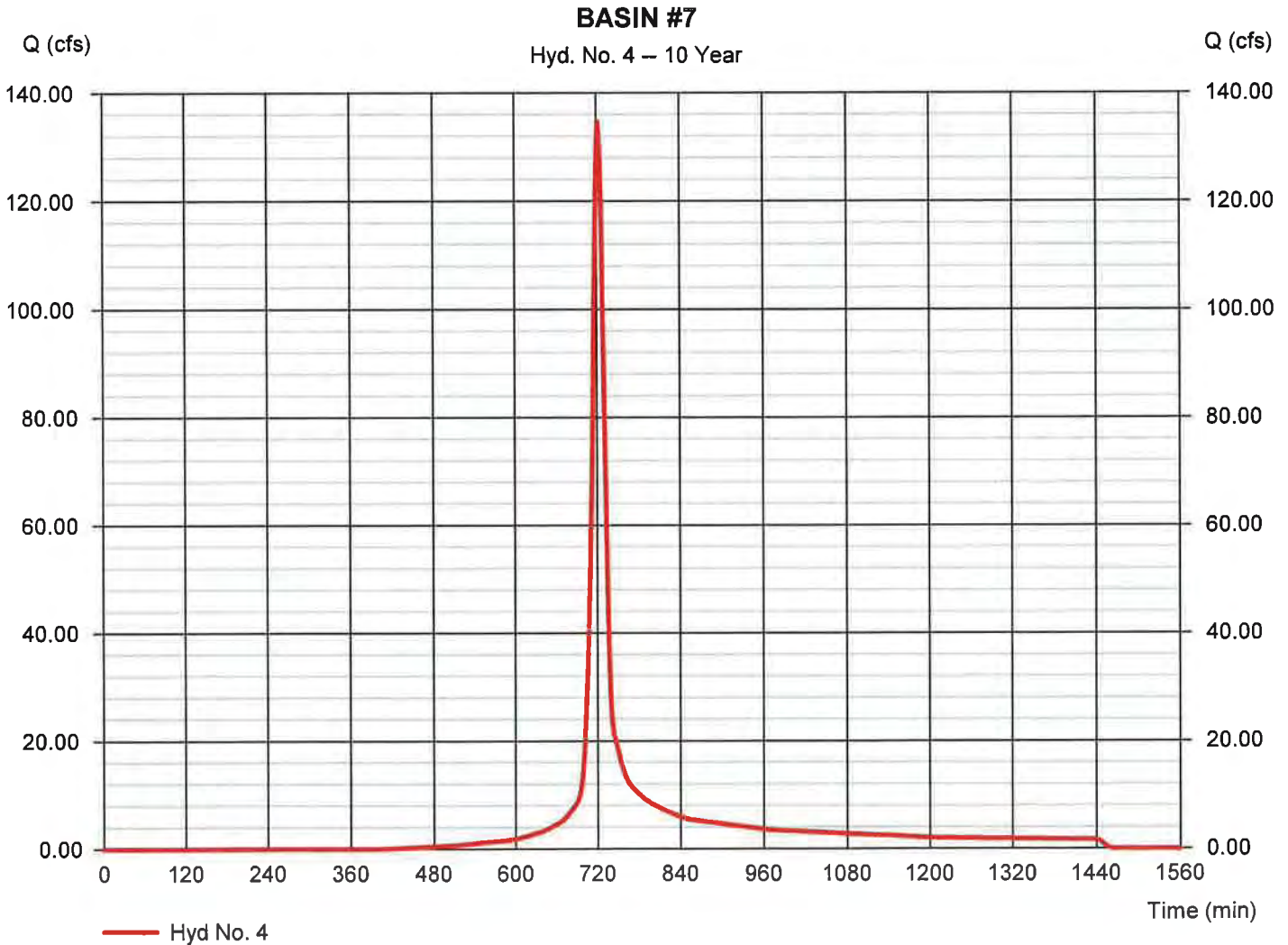

Hyd. No. 4

BASIN #7

<u>Description</u>	<u>A</u>	<u>B</u>	<u>C</u>	<u>Totals</u>
Sheet Flow				
Manning's n-value	= 0.050	0.011	0.011	
Flow length (ft)	= 200.0	0.0	0.0	
Two-year 24-hr precip. (in)	= 3.62	0.00	0.00	
Land slope (%)	= 1.70	0.00	0.00	
Travel Time (min)	= 7.11	+ 0.00	+ 0.00	= 7.11
Shallow Concentrated Flow				
Flow length (ft)	= 506.00	0.00	0.00	
Watercourse slope (%)	= 8.10	0.00	0.00	
Surface description	= Unpaved	Paved	Paved	
Average velocity (ft/s)	=4.59	0.00	0.00	
Travel Time (min)	= 1.84	+ 0.00	+ 0.00	= 1.84
Channel Flow				
X sectional flow area (sqft)	= 20.00	0.00	0.00	
Wetted perimeter (ft)	= 14.00	0.00	0.00	
Channel slope (%)	= 2.10	0.00	0.00	
Manning's n-value	= 0.050	0.015	0.015	
Velocity (ft/s)	=5.48	0.00	0.00	
Flow length (ft)	{{0}}2086.0	0.0	0.0	
Travel Time (min)	= 6.34	+ 0.00	+ 0.00	= 6.34
Total Travel Time, Tc				15.30 min

Hydrograph Report

Hydraflow Hydrographs Extension for AutoCAD® Civil 3D® 2014 by Autodesk, Inc. v10.3

Friday, 10 / 31 / 2014

Hyd. No. 5

BASIN #9

Hydrograph type	= SCS Runoff	Peak discharge	= 199.50 cfs
Storm frequency	= 10 yrs	Time to peak	= 728 min
Time interval	= 2 min	Hyd. volume	= 741,644 cuft
Drainage area	= 85.920 ac	Curve number	= 72*
Basin Slope	= 0.0 %	Hydraulic length	= 0 ft
Tc method	= TR55	Time of conc. (Tc)	= 26.80 min
Total precip.	= 5.28 in	Distribution	= Type II
Storm duration	= 24 hrs	Shape factor	= 484

* Composite (Area/CN) = [(56.000 x 86) + (16.030 x 55) + (9.190 x 91)] / 85.920

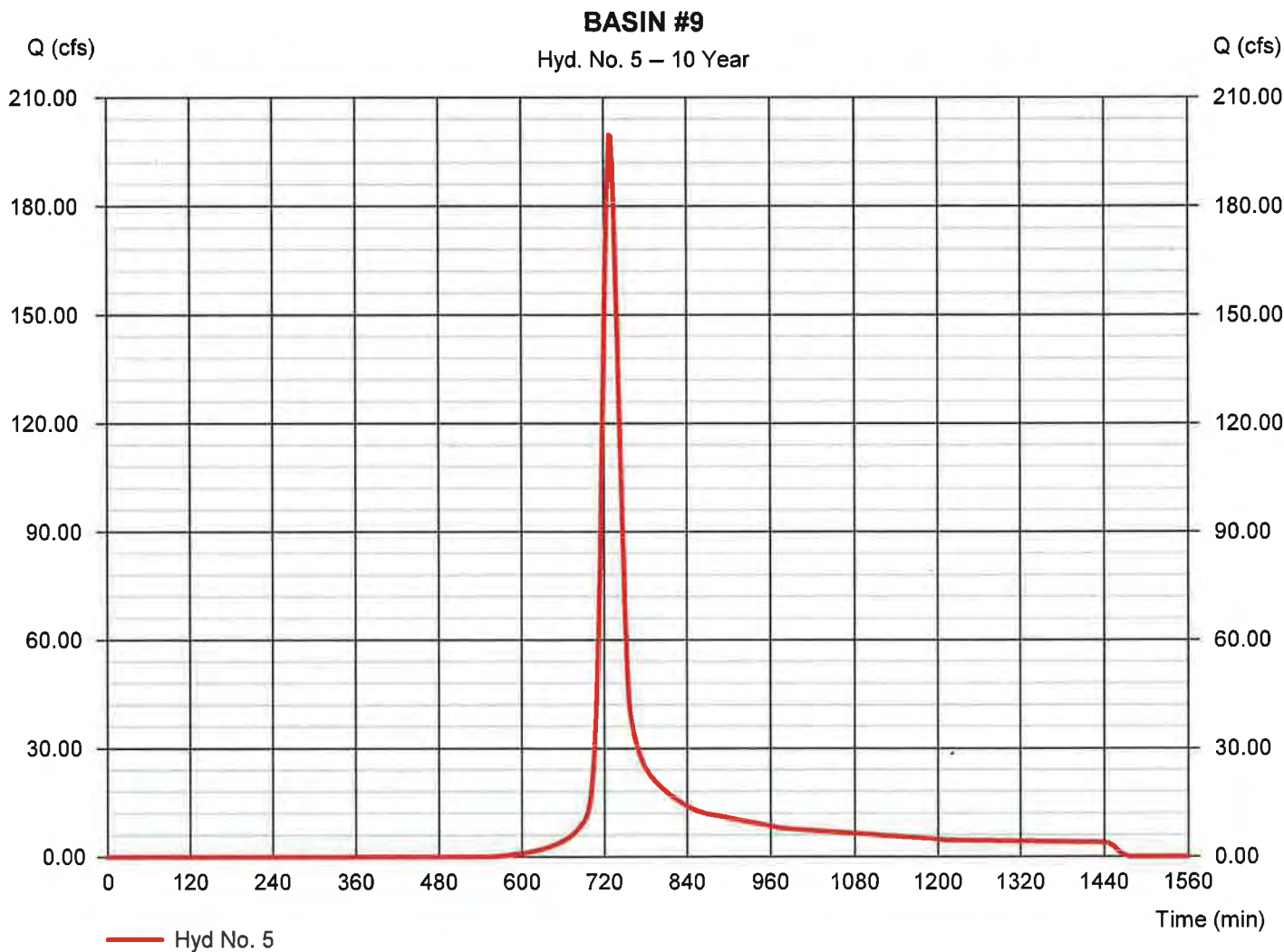

Hyd. No. 5

BASIN #9

<u>Description</u>	<u>A</u>	<u>B</u>	<u>C</u>	<u>Totals</u>
Sheet Flow				
Manning's n-value	= 0.400	0.011	0.011	
Flow length (ft)	= 100.0	0.0	0.0	
Two-year 24-hr precip. (in)	= 3.62	0.00	0.00	
Land slope (%)	= 1.50	0.00	0.00	
Travel Time (min)	= 22.65	+ 0.00	+ 0.00	= 22.65
Shallow Concentrated Flow				
Flow length (ft)	= 230.00	0.00	0.00	
Watercourse slope (%)	= 7.80	0.00	0.00	
Surface description	= Unpaved	Paved	Paved	
Average velocity (ft/s)	=4.51	0.00	0.00	
Travel Time (min)	= 0.85	+ 0.00	+ 0.00	= 0.85
Channel Flow				
X sectional flow area (sqft)	= 20.00	0.00	0.00	
Wetted perimeter (ft)	= 14.00	0.00	0.00	
Channel slope (%)	= 3.30	0.00	0.00	
Manning's n-value	= 0.050	0.015	0.015	
Velocity (ft/s)	=6.87	0.00	0.00	
Flow length (ft)	{{0}}1351.0	0.0	0.0	
Travel Time (min)	= 3.28	+ 0.00	+ 0.00	= 3.28
Total Travel Time, Tc				26.80 min

Hydrograph Summary Report

Hydraflow Hydrographs Extension for AutoCAD® Civil 3D® 2014 by Autodesk, Inc. v10.3

Hyd. No.	Hydrograph type (origin)	Peak flow (cfs)	Time interval (min)	Time to Peak (min)	Hyd. volume (cuft)	Inflow hyd(s)	Maximum elevation (ft)	Total strge used (cuft)	Hydrograph Description
1	SCS Runoff	310.28	2	718	747,497	---	---	---	BASIN #5
2	SCS Runoff	53.49	2	722	154,408	---	---	---	BASIN #1
3	SCS Runoff	98.71	2	720	265,493	---	---	---	BASIN #2
4	SCS Runoff	171.36	2	722	485,116	---	---	---	BASIN #7
5	SCS Runoff	268.73	2	728	989,740	---	---	---	BASIN #9
Basins-Phase 2.gpw					Return Period: 25 Year			Friday, 10 / 31 / 2014	

Hydrograph Report

Hyd. No. 1

BASIN #5

Hydrograph type	= SCS Runoff	Peak discharge	= 310.28 cfs
Storm frequency	= 25 yrs	Time to peak	= 718 min
Time interval	= 2 min	Hyd. volume	= 747,497 cuft
Drainage area	= 42.060 ac	Curve number	= 88*
Basin Slope	= 0.0 %	Hydraulic length	= 0 ft
Tc method	= TR55	Time of conc. (Tc)	= 9.50 min
Total precip.	= 6.28 in	Distribution	= Type II
Storm duration	= 24 hrs	Shape factor	= 484

* Composite (Area/CN) = [(35.010 x 86) + (3.880 x 91) + (3.170 x 94)] / 42.060

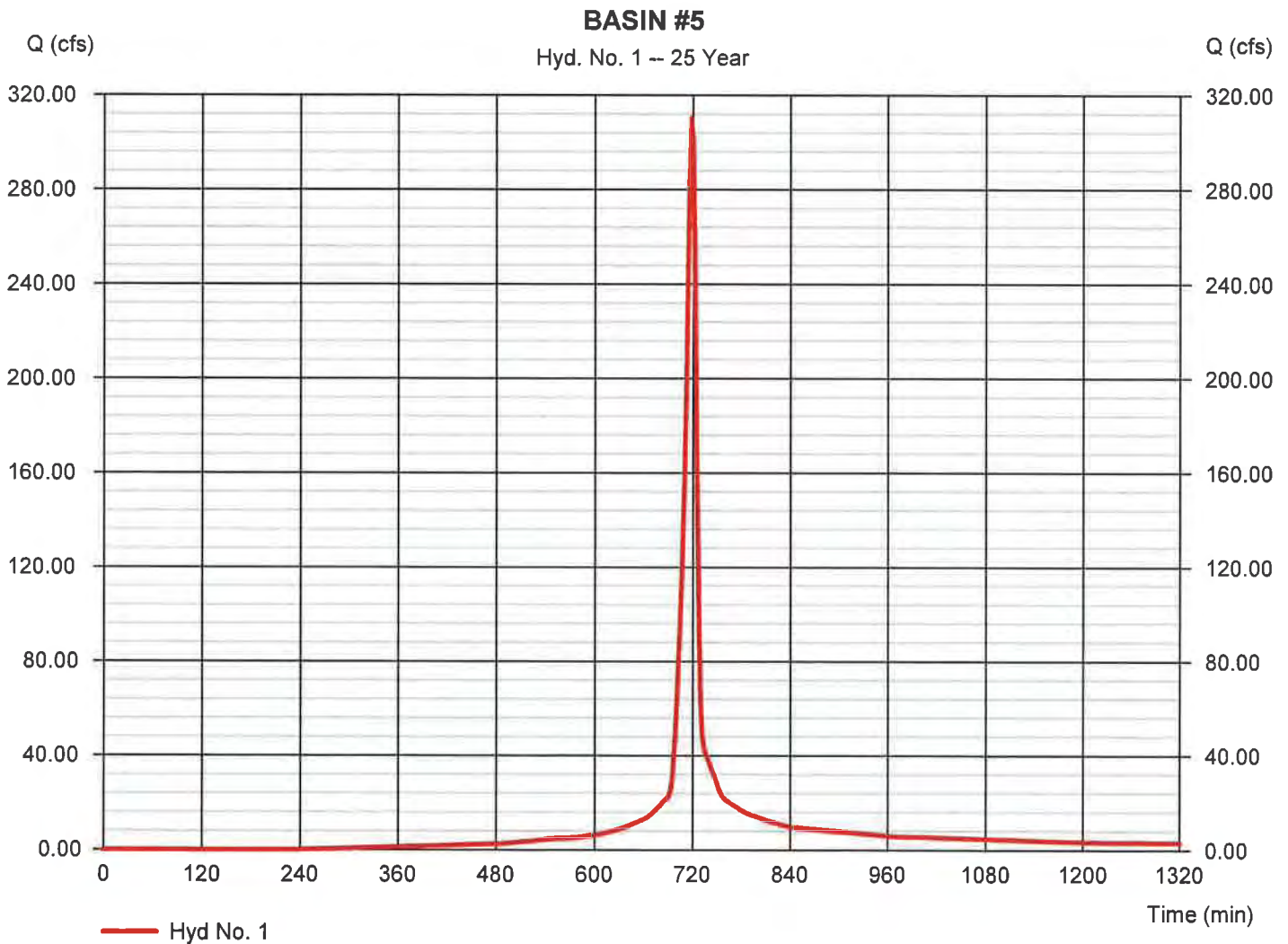

Hydrograph Report

Hydraflow Hydrographs Extension for AutoCAD® Civil 3D® 2014 by Autodesk, Inc. v10.3

Friday, 10 / 31 / 2014

Hyd. No. 2

BASIN #1

Hydrograph type	= SCS Runoff	Peak discharge	= 53.49 cfs
Storm frequency	= 25 yrs	Time to peak	= 722 min
Time interval	= 2 min	Hyd. volume	= 154,408 cuft
Drainage area	= 9.330 ac	Curve number	= 86*
Basin Slope	= 0.0 %	Hydraulic length	= 0 ft
Tc method	= TR55	Time of conc. (Tc)	= 13.80 min
Total precip.	= 6.28 in	Distribution	= Type II
Storm duration	= 24 hrs	Shape factor	= 484

* Composite (Area/CN) = [(9.330 x 86)] / 9.330

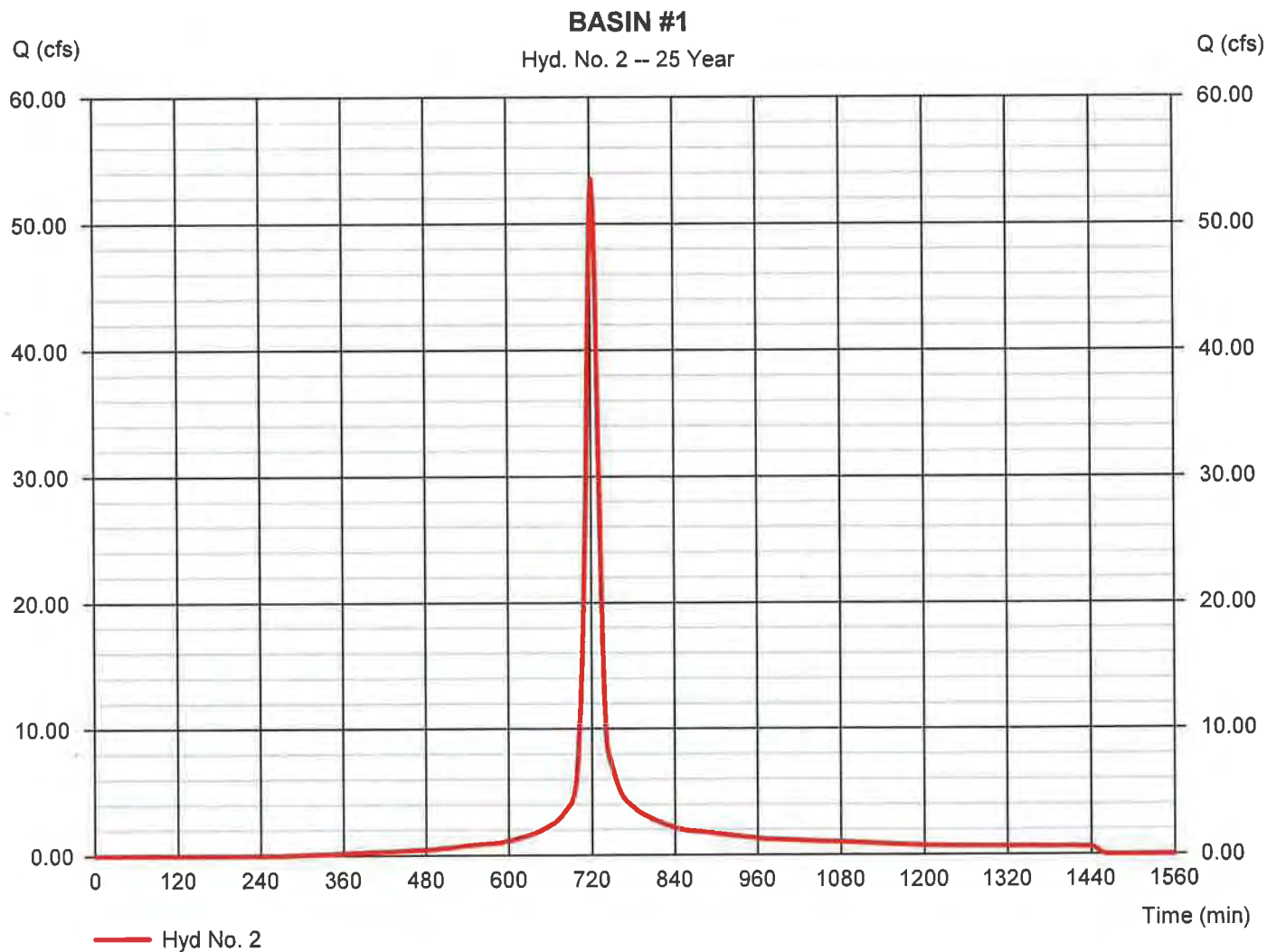

Hyd. No. 3

BASIN #2

Hydrograph type	= SCS Runoff	Peak discharge	= 98.71 cfs
Storm frequency	= 25 yrs	Time to peak	= 720 min
Time interval	= 2 min	Hyd. volume	= 265,493 cuft
Drainage area	= 14.820 ac	Curve number	= 87*
Basin Slope	= 0.0 %	Hydraulic length	= 0 ft
Tc method	= TR55	Time of conc. (Tc)	= 13.30 min
Total precip.	= 6.28 in	Distribution	= Type II
Storm duration	= 24 hrs	Shape factor	= 484

* Composite (Area/CN) = [(11.890 x 86) + (2.930 x 91)] / 14.820

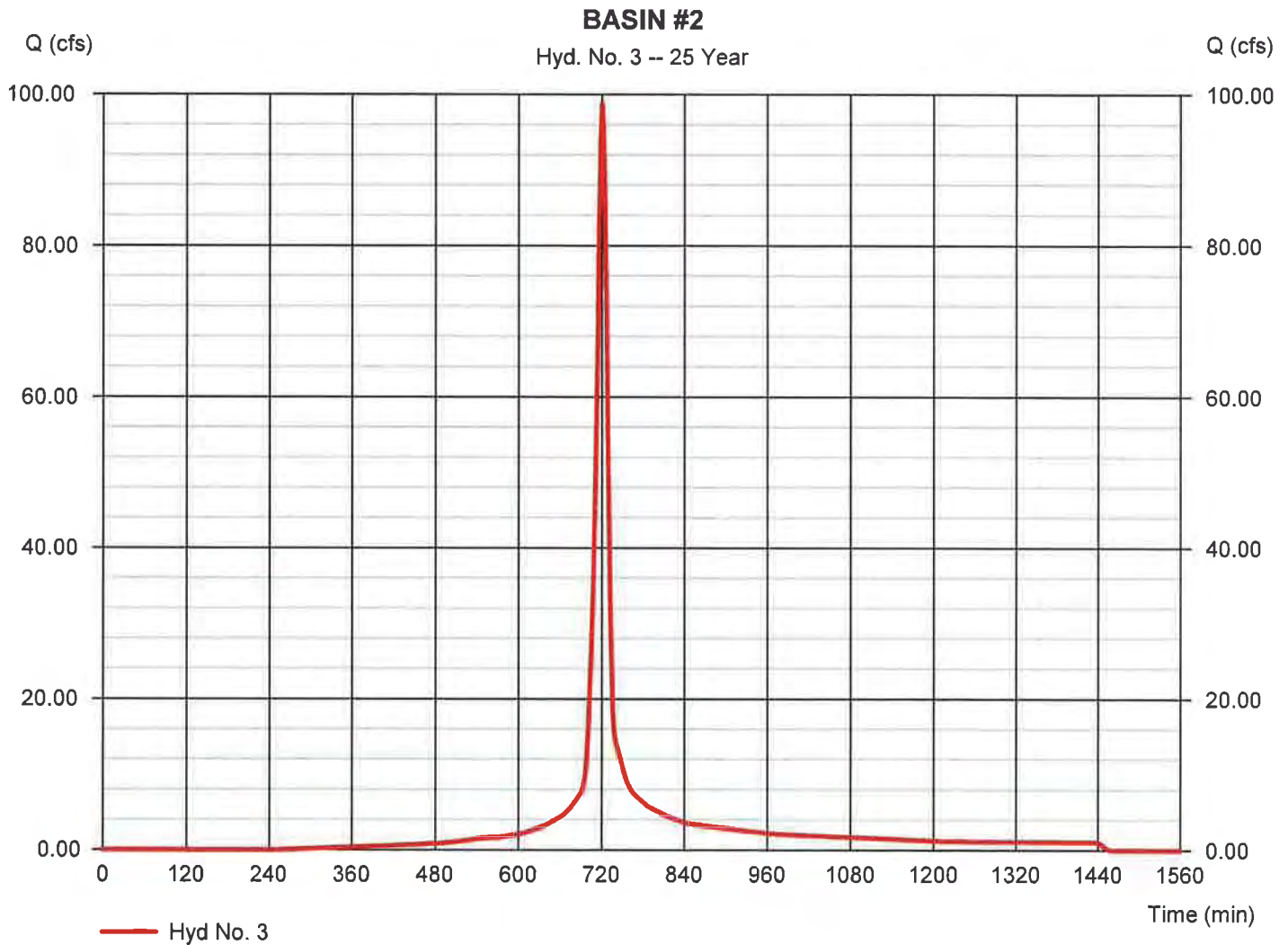

Hydrograph Report

Hydraflow Hydrographs Extension for AutoCAD® Civil 3D® 2014 by Autodesk, Inc. v10.3

Friday, 10 / 31 / 2014

Hyd. No. 4

BASIN #7

Hydrograph type	= SCS Runoff	Peak discharge	= 171.36 cfs
Storm frequency	= 25 yrs	Time to peak	= 722 min
Time interval	= 2 min	Hyd. volume	= 485,116 cuft
Drainage area	= 33.110 ac	Curve number	= 81*
Basin Slope	= 0.0 %	Hydraulic length	= 0 ft
Tc method	= TR55	Time of conc. (Tc)	= 15.30 min
Total precip.	= 6.28 in	Distribution	= Type II
Storm duration	= 24 hrs	Shape factor	= 484

* Composite (Area/CN) = [(26.860 x 86) + (2.390 x 91) + (0.530 x 61) + (3.330 x 74)] / 33.110

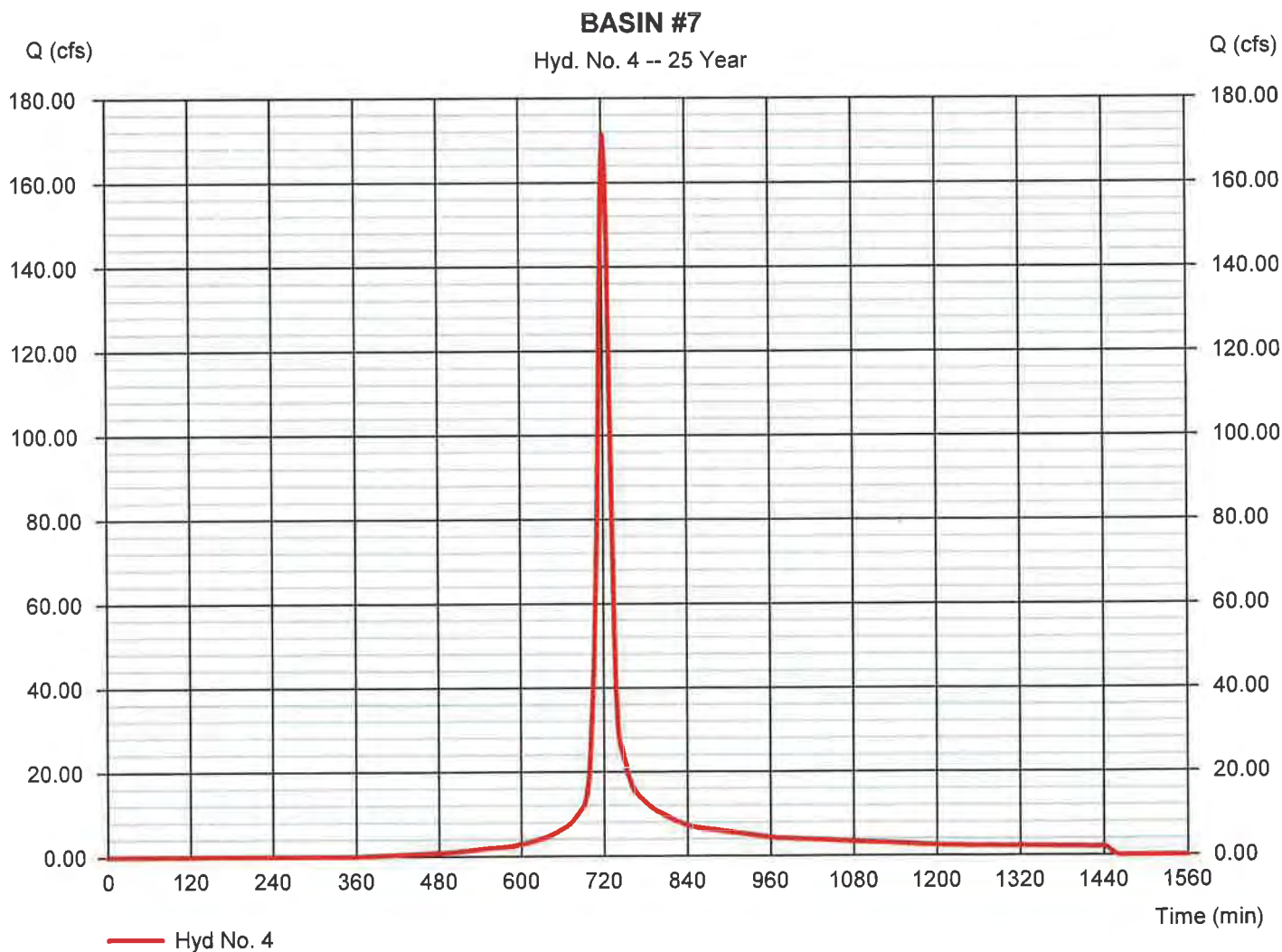

Hydrograph Report

Hyd. No. 5

BASIN #9

Hydrograph type	= SCS Runoff	Peak discharge	= 268.73 cfs
Storm frequency	= 25 yrs	Time to peak	= 728 min
Time interval	= 2 min	Hyd. volume	= 989,740 cuft
Drainage area	= 85.920 ac	Curve number	= 72*
Basin Slope	= 0.0 %	Hydraulic length	= 0 ft
Tc method	= TR55	Time of conc. (Tc)	= 26.80 min
Total precip.	= 6.28 in	Distribution	= Type II
Storm duration	= 24 hrs	Shape factor	= 484

* Composite (Area/CN) = [(56.000 x 86) + (16.030 x 55) + (9.190 x 91)] / 85.920

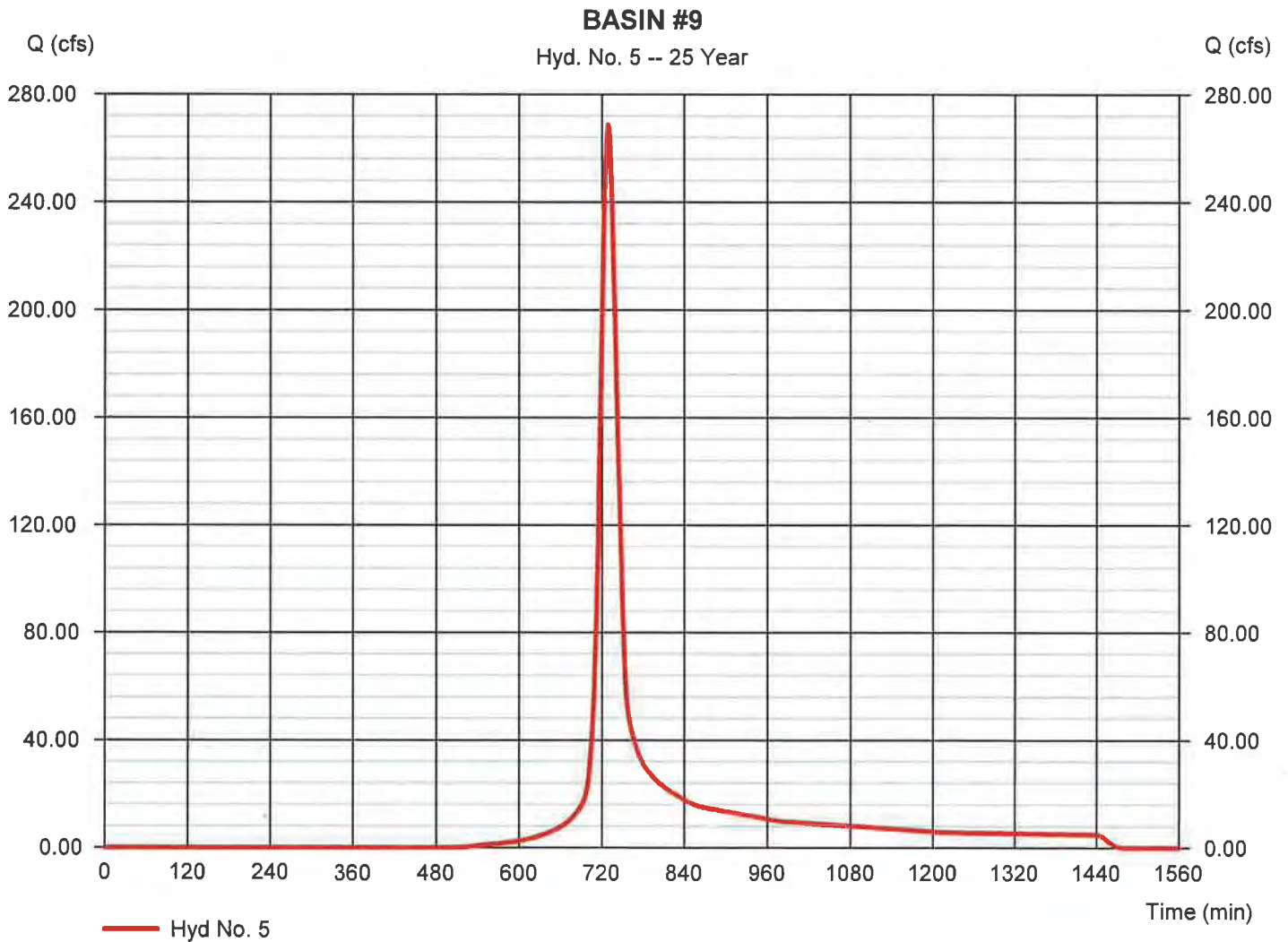

Hydrograph Summary Report

Hydraflow Hydrographs Extension for AutoCAD® Civil 3D® 2014 by Autodesk, Inc. v10.3

Hyd. No.	Hydrograph type (origin)	Peak flow (cfs)	Time interval (min)	Time to Peak (min)	Hyd. volume (cuft)	Inflow hyd(s)	Maximum elevation (ft)	Total strge used (cuft)	Hydrograph Description
1	SCS Runoff	402.08	2	718	984,912	----	----	----	BASIN #5
2	SCS Runoff	70.07	2	722	205,231	----	----	----	BASIN #1
3	SCS Runoff	128.64	2	720	351,336	----	----	----	BASIN #2
4	SCS Runoff	230.40	2	722	659,648	----	----	----	BASIN #7
5	SCS Runoff	384.06	2	728	1,408,990	----	----	----	BASIN #9
Basins-Phase 2.gpw					Return Period: 100 Year			Friday, 10 / 31 / 2014	

Hydrograph Report

Hyd. No. 1

BASIN #5

Hydrograph type	= SCS Runoff	Peak discharge	= 402.08 cfs
Storm frequency	= 100 yrs	Time to peak	= 718 min
Time interval	= 2 min	Hyd. volume	= 984,912 cuft
Drainage area	= 42.060 ac	Curve number	= 88*
Basin Slope	= 0.0 %	Hydraulic length	= 0 ft
Tc method	= TR55	Time of conc. (Tc)	= 9.50 min
Total precip.	= 7.88 in	Distribution	= Type II
Storm duration	= 24 hrs	Shape factor	= 484

* Composite (Area/CN) = [(35.010 x 86) + (3.880 x 91) + (3.170 x 94)] / 42.060

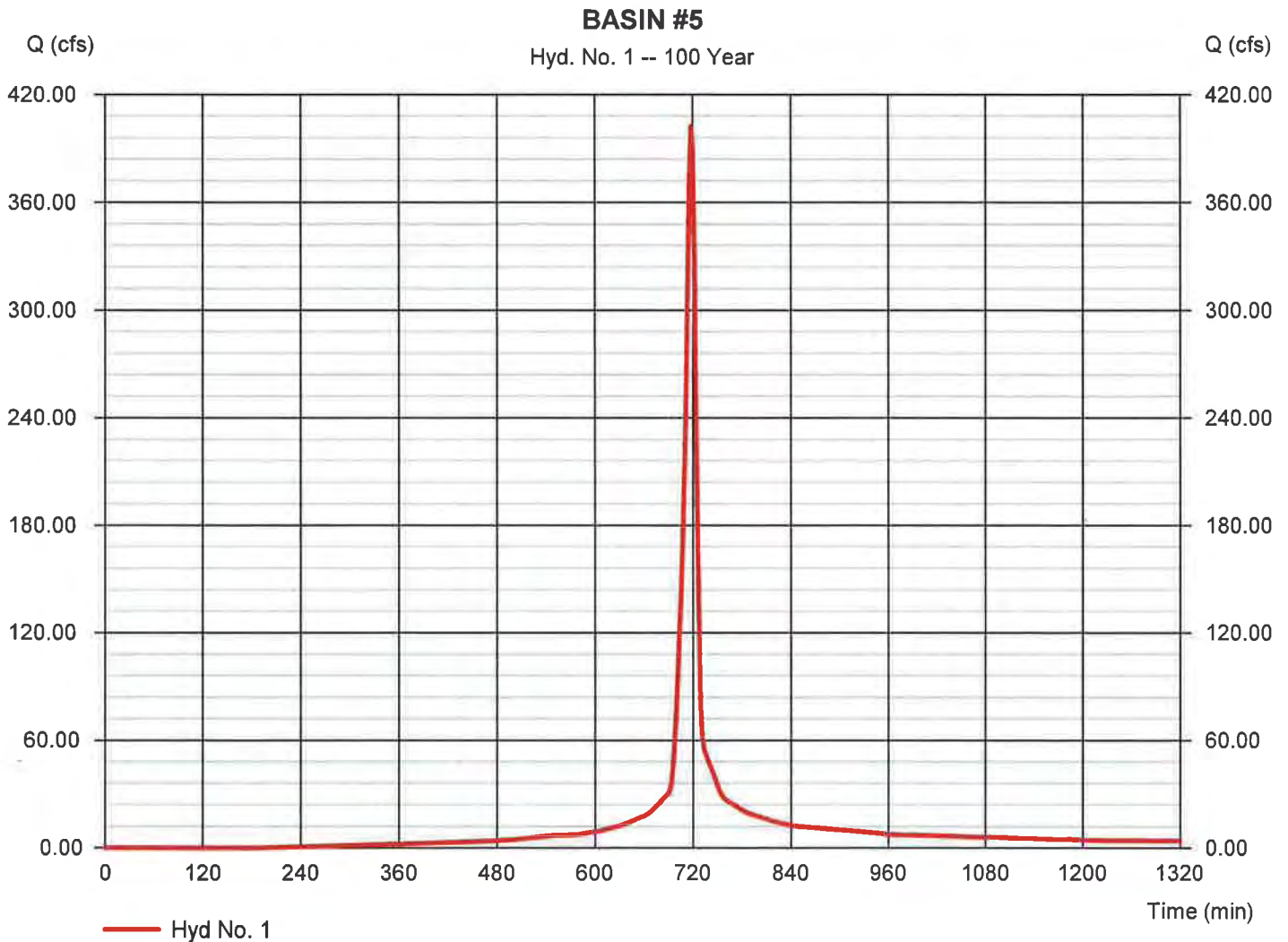

Hydrograph Report

Hydraflow Hydrographs Extension for AutoCAD® Civil 3D® 2014 by Autodesk, Inc. v10.3

Friday, 10 / 31 / 2014

Hyd. No. 2

BASIN #1

Hydrograph type	= SCS Runoff	Peak discharge	= 70.07 cfs
Storm frequency	= 100 yrs	Time to peak	= 722 min
Time interval	= 2 min	Hyd. volume	= 205,231 cuft
Drainage area	= 9.330 ac	Curve number	= 86*
Basin Slope	= 0.0 %	Hydraulic length	= 0 ft
Tc method	= TR55	Time of conc. (Tc)	= 13.80 min
Total precip.	= 7.88 in	Distribution	= Type II
Storm duration	= 24 hrs	Shape factor	= 484

* Composite (Area/CN) = [(9.330 x 86)] / 9.330

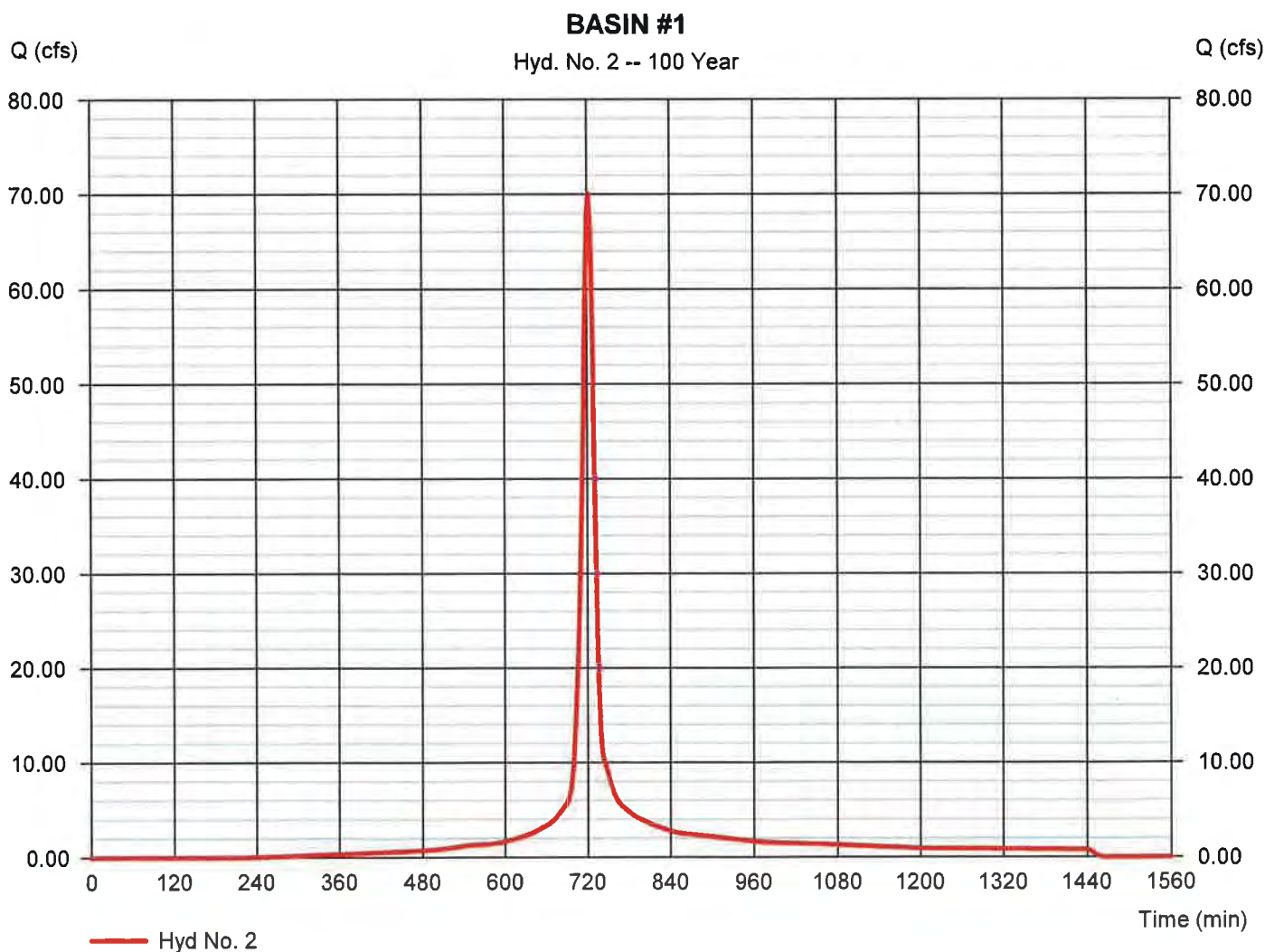

Hydrograph Report

Hyd. No. 3

BASIN #2

Hydrograph type	= SCS Runoff	Peak discharge	= 128.64 cfs
Storm frequency	= 100 yrs	Time to peak	= 720 min
Time interval	= 2 min	Hyd. volume	= 351,336 cuft
Drainage area	= 14.820 ac	Curve number	= 87*
Basin Slope	= 0.0 %	Hydraulic length	= 0 ft
Tc method	= TR55	Time of conc. (Tc)	= 13.30 min
Total precip.	= 7.88 in	Distribution	= Type II
Storm duration	= 24 hrs	Shape factor	= 484

* Composite (Area/CN) = [(11.890 x 86) + (2.930 x 91)] / 14.820

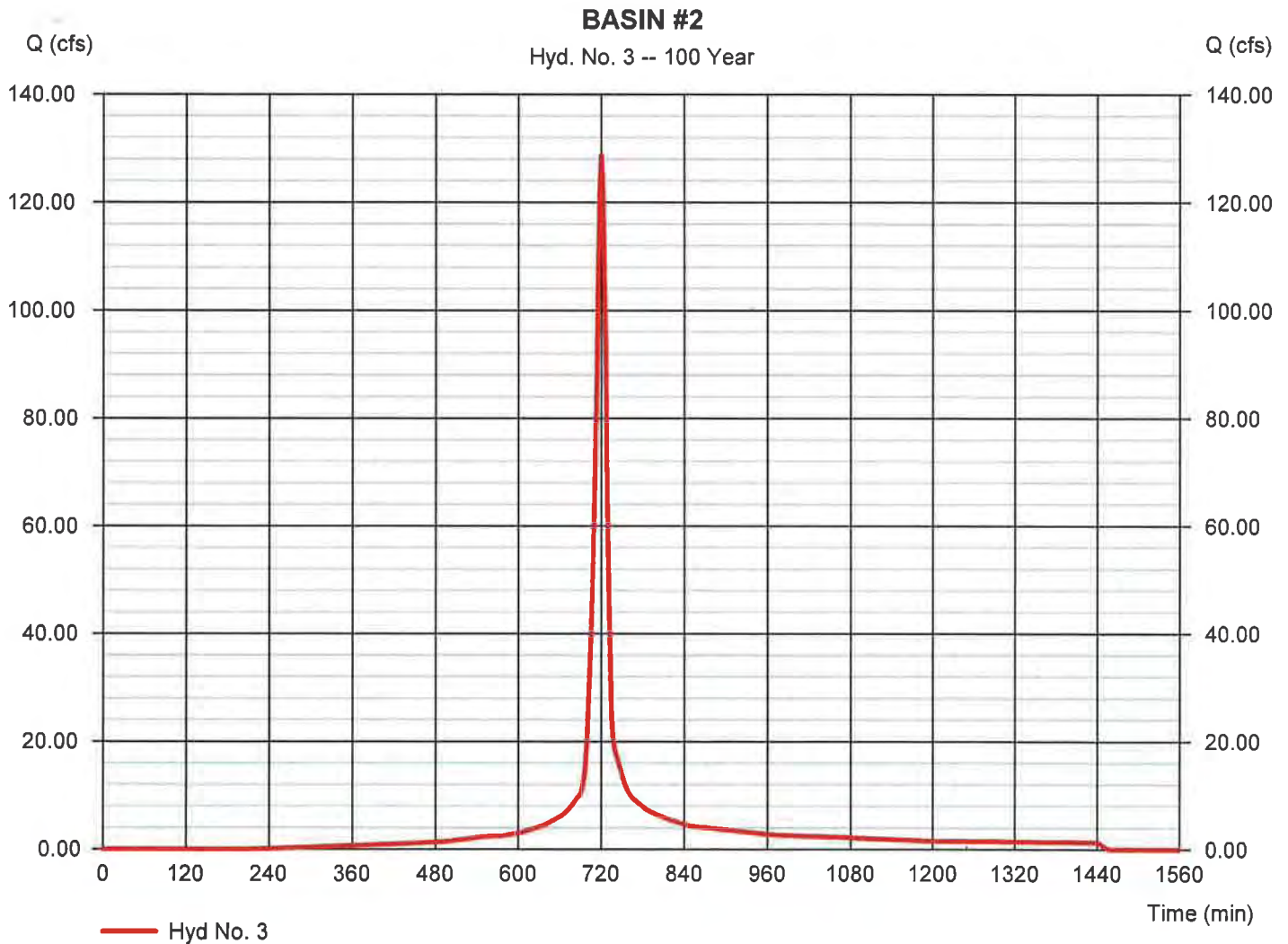

Hydrograph Report

Hydraflow Hydrographs Extension for AutoCAD® Civil 3D® 2014 by Autodesk, Inc. v10.3

Friday, 10 / 31 / 2014

Hyd. No. 4

BASIN #7

Hydrograph type	= SCS Runoff	Peak discharge	= 230.40 cfs
Storm frequency	= 100 yrs	Time to peak	= 722 min
Time interval	= 2 min	Hyd. volume	= 659,648 cuft
Drainage area	= 33.110 ac	Curve number	= 81*
Basin Slope	= 0.0 %	Hydraulic length	= 0 ft
Tc method	= TR55	Time of conc. (Tc)	= 15.30 min
Total precip.	= 7.88 in	Distribution	= Type II
Storm duration	= 24 hrs	Shape factor	= 484

* Composite (Area/CN) = [(26.860 x 86) + (2.390 x 91) + (0.530 x 61) + (3.330 x 74)] / 33.110

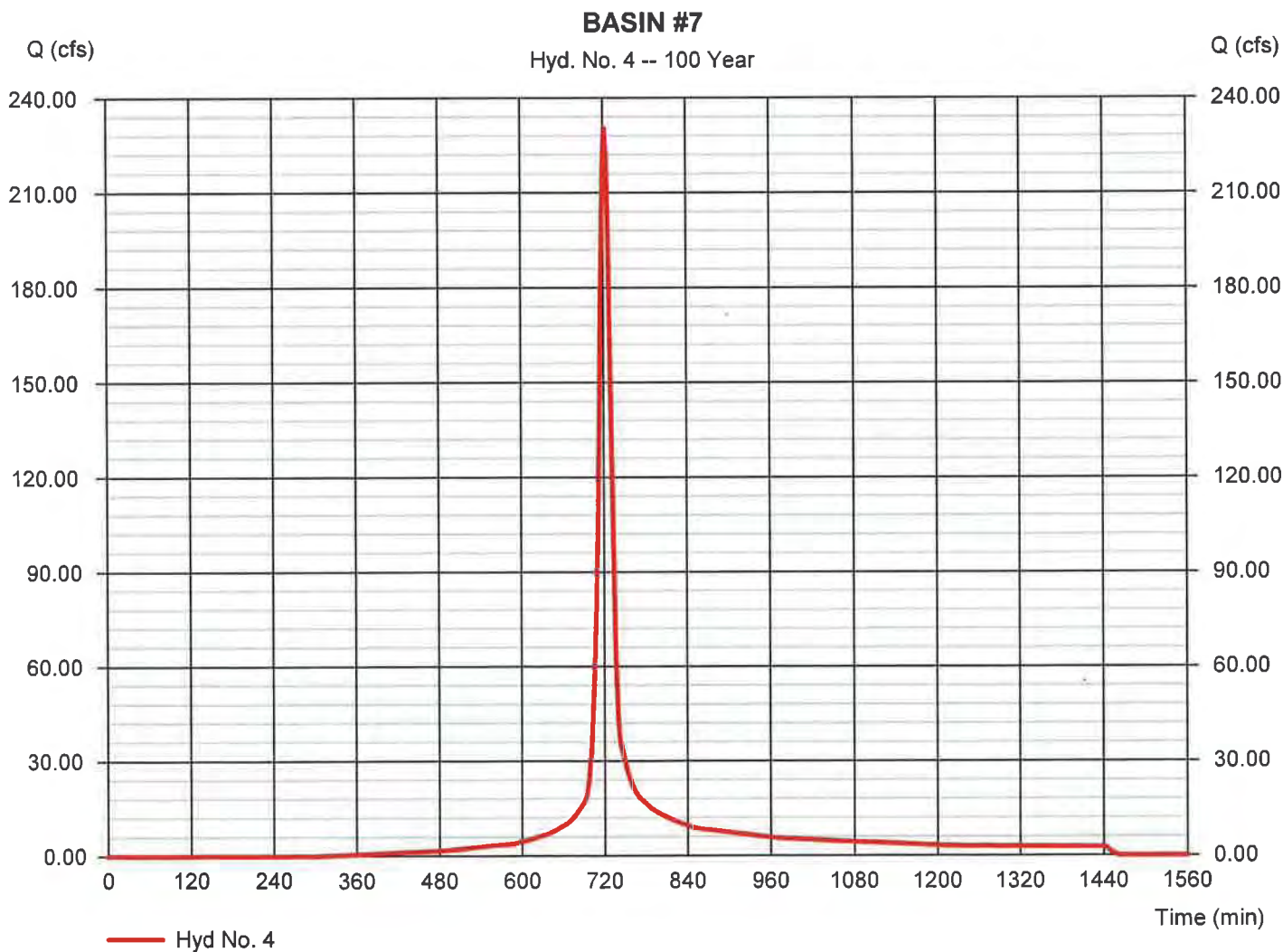

Hydrograph Report

Hydraflow Hydrographs Extension for AutoCAD® Civil 3D® 2014 by Autodesk, Inc. v10.3

Friday, 10 / 31 / 2014

Hyd. No. 5

BASIN #9

Hydrograph type	= SCS Runoff	Peak discharge	= 384.06 cfs
Storm frequency	= 100 yrs	Time to peak	= 728 min
Time interval	= 2 min	Hyd. volume	= 1,408,990 cuft
Drainage area	= 85.920 ac	Curve number	= 72*
Basin Slope	= 0.0 %	Hydraulic length	= 0 ft
Tc method	= TR55	Time of conc. (Tc)	= 26.80 min
Total precip.	= 7.88 in	Distribution	= Type II
Storm duration	= 24 hrs	Shape factor	= 484

* Composite (Area/CN) = [(56.000 x 86) + (16.030 x 55) + (9.190 x 91)] / 85.920

BASIN #9

Hyd. No. 5 -- 100 Year

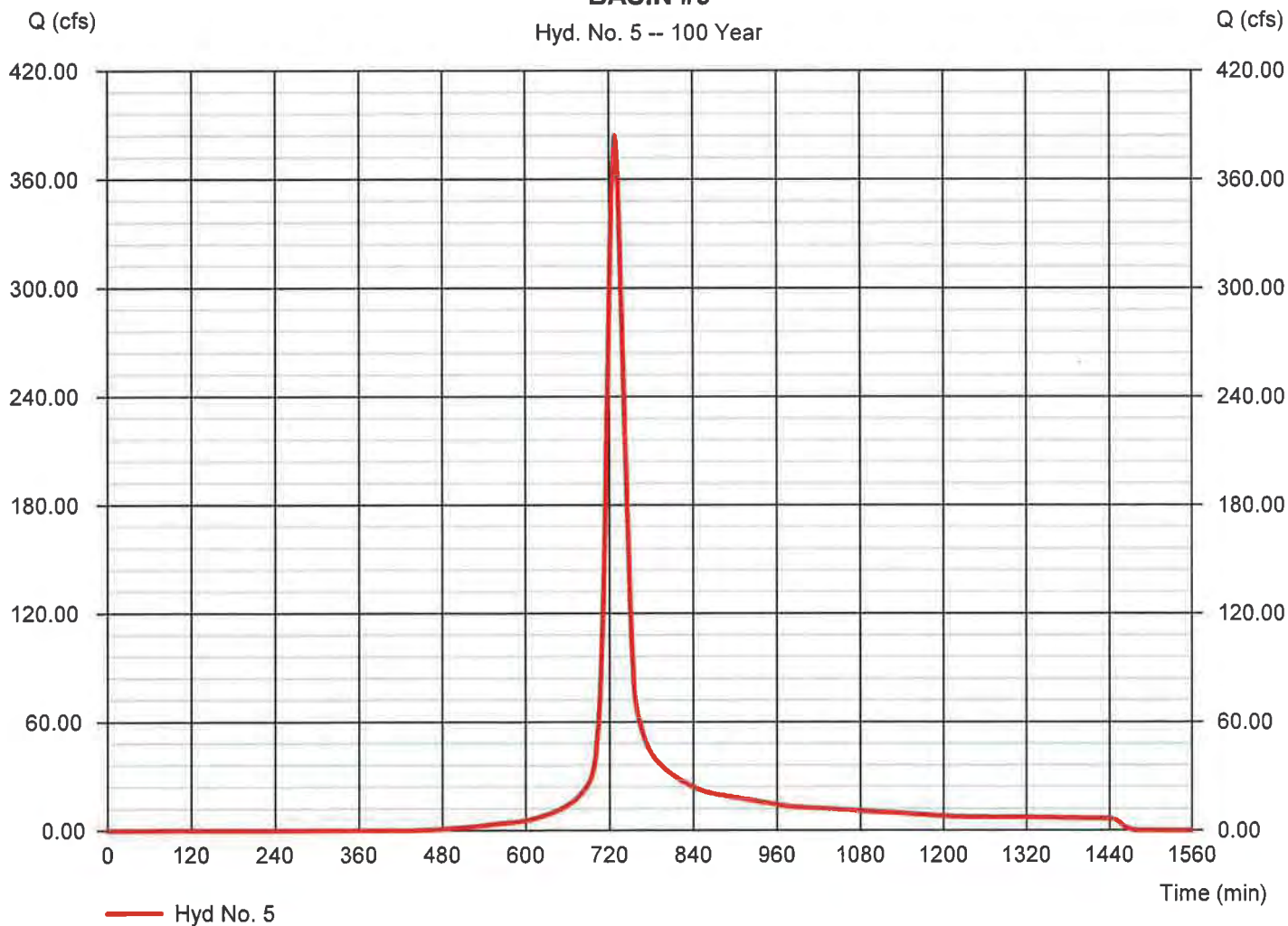

This page intentionally left blank.



NOAA Atlas 14, Volume 2, Version 3
 Location name: Sanford, North Carolina, US*
 Latitude: 35.5361°, Longitude: -79.1459°
 Elevation: 297 ft*
 * source: Google Maps



POINT PRECIPITATION FREQUENCY ESTIMATES

G.M. Bonnin, D. Martin, B. Lin, T. Parzybok, M.Yekta, and D. Riley

NOAA, National Weather Service, Silver Spring, Maryland

[PF tabular](#) | [PF graphical](#) | [Maps & aerials](#)

PF tabular

PDS-based point precipitation frequency estimates with 90% confidence intervals (in inches) ¹										
Duration	Average recurrence interval (years)									
	1	2	5	10	25	50	100	200	500	1000
5-min	0.425 (0.388-0.468)	0.503 (0.459-0.553)	0.583 (0.532-0.642)	0.641 (0.583-0.704)	0.707 (0.640-0.776)	0.751 (0.678-0.824)	0.793 (0.711-0.869)	0.829 (0.740-0.909)	0.870 (0.769-0.953)	0.900 (0.790-0.987)
10-min	0.680 (0.620-0.747)	0.804 (0.733-0.885)	0.934 (0.852-1.03)	1.03 (0.933-1.13)	1.13 (1.02-1.24)	1.20 (1.08-1.31)	1.26 (1.13-1.38)	1.31 (1.17-1.44)	1.38 (1.22-1.51)	1.42 (1.24-1.56)
15-min	0.849 (0.775-0.934)	1.01 (0.922-1.11)	1.18 (1.08-1.30)	1.30 (1.18-1.42)	1.43 (1.29-1.57)	1.52 (1.37-1.66)	1.59 (1.43-1.75)	1.66 (1.48-1.82)	1.73 (1.53-1.90)	1.78 (1.56-1.95)
30-min	1.17 (1.06-1.28)	1.40 (1.27-1.54)	1.68 (1.53-1.85)	1.88 (1.71-2.06)	2.12 (1.91-2.32)	2.28 (2.06-2.50)	2.44 (2.19-2.67)	2.58 (2.30-2.83)	2.76 (2.44-3.02)	2.88 (2.53-3.16)
60-min	1.45 (1.33-1.60)	1.75 (1.60-1.93)	2.15 (1.96-2.37)	2.45 (2.23-2.69)	2.82 (2.55-3.09)	3.09 (2.79-3.39)	3.36 (3.01-3.68)	3.62 (3.23-3.97)	3.95 (3.50-4.33)	4.20 (3.69-4.61)
2-hr	1.71 (1.55-1.90)	2.07 (1.88-2.30)	2.58 (2.34-2.87)	2.96 (2.67-3.28)	3.45 (3.10-3.82)	3.83 (3.42-4.24)	4.20 (3.73-4.65)	4.58 (4.03-5.06)	5.06 (4.42-5.60)	5.44 (4.71-6.02)
3-hr	1.82 (1.65-2.02)	2.20 (2.00-2.45)	2.75 (2.50-3.05)	3.18 (2.87-3.52)	3.74 (3.36-4.14)	4.19 (3.74-4.63)	4.64 (4.11-5.13)	5.11 (4.49-5.64)	5.74 (4.99-6.35)	6.24 (5.36-6.90)
6-hr	2.17 (1.99-2.40)	2.63 (2.40-2.90)	3.29 (3.00-3.63)	3.81 (3.46-4.19)	4.51 (4.07-4.95)	5.07 (4.54-5.56)	5.64 (5.01-6.18)	6.23 (5.48-6.83)	7.05 (6.12-7.72)	7.70 (6.60-8.44)
12-hr	2.57 (2.35-2.84)	3.11 (2.84-3.44)	3.91 (3.56-4.32)	4.56 (4.13-5.02)	5.44 (4.89-5.98)	6.16 (5.49-6.75)	6.90 (6.10-7.56)	7.69 (6.72-8.41)	8.80 (7.56-9.62)	9.69 (8.21-10.6)
24-hr	3.00 (2.80-3.22)	3.62 (3.38-3.89)	4.55 (4.24-4.89)	5.28 (4.91-5.67)	6.28 (5.82-6.75)	7.07 (6.54-7.59)	7.88 (7.27-8.46)	8.72 (8.03-9.37)	9.88 (9.05-10.6)	10.8 (9.85-11.6)
2-day	3.49 (3.25-3.75)	4.20 (3.92-4.52)	5.25 (4.88-5.64)	6.07 (5.64-6.52)	7.18 (6.65-7.71)	8.06 (7.45-8.66)	8.97 (8.26-9.63)	9.90 (9.09-10.6)	11.2 (10.2-12.0)	12.2 (11.1-13.1)
3-day	3.70 (3.44-3.96)	4.45 (4.15-4.77)	5.52 (5.14-5.92)	6.36 (5.91-6.82)	7.52 (6.96-8.06)	8.44 (7.78-9.04)	9.37 (8.63-10.0)	10.3 (9.49-11.1)	11.7 (10.7-12.5)	12.7 (11.6-13.7)
4-day	3.90 (3.64-4.18)	4.69 (4.37-5.02)	5.79 (5.39-6.19)	6.66 (6.19-7.12)	7.86 (7.27-8.41)	8.81 (8.12-9.42)	9.78 (8.99-10.5)	10.8 (9.89-11.6)	12.2 (11.1-13.0)	13.2 (12.0-14.2)
7-day	4.49 (4.20-4.80)	5.36 (5.02-5.74)	6.54 (6.11-6.99)	7.47 (6.97-7.99)	8.76 (8.15-9.35)	9.78 (9.07-10.4)	10.8 (10.0-11.6)	11.9 (11.0-12.7)	13.4 (12.3-14.3)	14.5 (13.3-15.6)
10-day	5.12 (4.82-5.46)	6.10 (5.73-6.50)	7.34 (6.89-7.81)	8.31 (7.79-8.85)	9.62 (8.99-10.2)	10.6 (9.92-11.3)	11.7 (10.9-12.4)	12.7 (11.8-13.6)	14.2 (13.1-15.1)	15.3 (14.1-16.3)
20-day	6.89 (6.49-7.33)	8.14 (7.66-8.64)	9.62 (9.04-10.2)	10.8 (10.1-11.4)	12.4 (11.6-13.1)	13.6 (12.7-14.4)	14.8 (13.8-15.8)	16.1 (14.9-17.1)	17.8 (16.5-19.0)	19.1 (17.6-20.4)
30-day	8.57 (8.09-9.09)	10.1 (9.50-10.7)	11.7 (11.1-12.5)	13.0 (12.2-13.8)	14.7 (13.8-15.6)	16.0 (15.0-17.0)	17.3 (16.2-18.4)	18.5 (17.3-19.7)	20.3 (18.8-21.6)	21.6 (20.0-23.0)
45-day	10.9 (10.4-11.5)	12.8 (12.1-13.5)	14.6 (13.9-15.4)	16.0 (15.2-16.9)	17.9 (16.9-18.9)	19.3 (18.2-20.3)	20.6 (19.4-21.8)	22.0 (20.6-23.2)	23.7 (22.2-25.1)	25.1 (23.4-26.5)
60-day	13.0 (12.4-13.7)	15.2 (14.5-16.0)	17.2 (16.3-18.1)	18.8 (17.8-19.8)	20.8 (19.7-21.9)	22.3 (21.1-23.5)	23.7 (22.4-25.0)	25.1 (23.7-26.5)	26.9 (25.3-28.5)	28.3 (26.6-30.0)

¹ Precipitation frequency (PF) estimates in this table are based on frequency analysis of partial duration series (PDS). Numbers in parenthesis are PF estimates at lower and upper bounds of the 90% confidence interval. The probability that precipitation frequency estimates (for a given duration and average recurrence interval) will be greater than the upper bound (or less than the lower bound) is 5%. Estimates at upper bounds are not checked against probable maximum precipitation (PMP) estimates and may be higher than currently valid PMP values. Please refer to NOAA Atlas 14 document for more information.

[Back to Top](#)

PF graphical

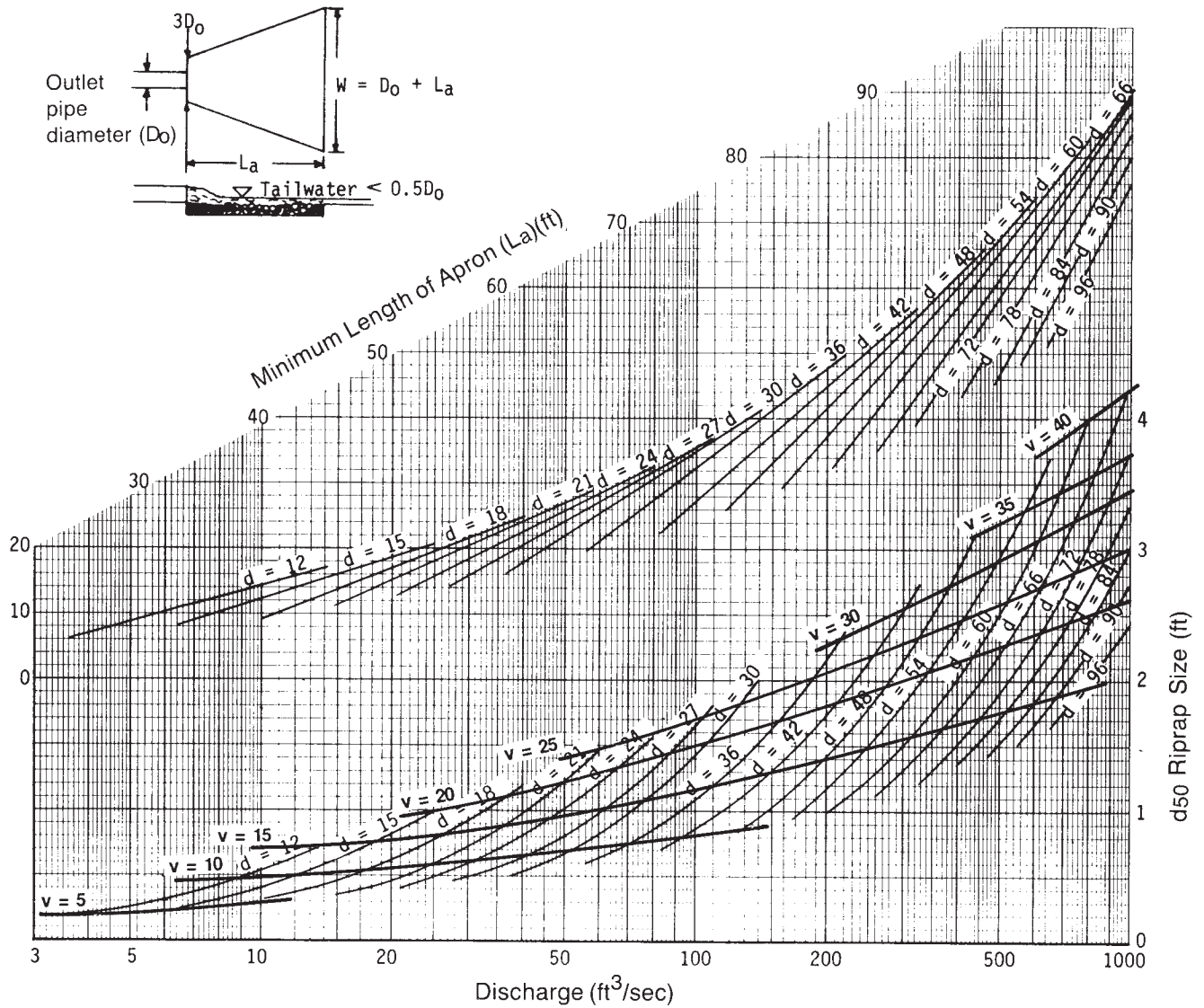

Curves may not be extrapolated.

Figure 8.06a Design of outlet protection protection from a round pipe flowing full, minimum tailwater condition ($T_w < 0.5$ diameter).

Table 2-2a Runoff curve numbers for urban areas ^{1/}

Cover description	Average percent impervious area ^{2/}	Curve numbers for hydrologic soil group			
		A	B	C	D
<i>Fully developed urban areas (vegetation established)</i>					
Open space (lawns, parks, golf courses, cemeteries, etc.) ^{3/} :					
Poor condition (grass cover < 50%)		68	79	86	89
Fair condition (grass cover 50% to 75%)		49	69	79	84
Good condition (grass cover > 75%)		39	61	74	80
Impervious areas:					
Paved parking lots, roofs, driveways, etc. (excluding right-of-way)					
		98	98	98	98
Streets and roads:					
Paved; curbs and storm sewers (excluding right-of-way)					
		98	98	98	98
Paved; open ditches (including right-of-way)					
		83	89	92	93
Gravel (including right-of-way)					
		76	85	89	91
Dirt (including right-of-way)					
		72	82	87	89
Western desert urban areas:					
Natural desert landscaping (pervious areas only) ^{4/}					
		63	77	85	88
Artificial desert landscaping (impervious weed barrier, desert shrub with 1- to 2-inch sand or gravel mulch and basin borders)					
		96	96	96	96
Urban districts:					
Commercial and business					
	85	89	92	94	95
Industrial					
	72	81	88	91	93
Residential districts by average lot size:					
1/8 acre or less (town houses)					
	65	77	85	90	92
1/4 acre					
	38	61	75	83	87
1/3 acre					
	30	57	72	81	86
1/2 acre					
	25	54	70	80	85
1 acre					
	20	51	68	79	84
2 acres					
	12	46	65	77	82
<i>Developing urban areas</i>					
Newly graded areas (pervious areas only, no vegetation) ^{5/}					
		77	86	91	94
Idle lands (CN's are determined using cover types similar to those in table 2-2c).					

¹ Average runoff condition, and $I_a = 0.2S$.² The average percent impervious area shown was used to develop the composite CN's. Other assumptions are as follows: impervious areas are directly connected to the drainage system, impervious areas have a CN of 98, and pervious areas are considered equivalent to open space in good hydrologic condition. CN's for other combinations of conditions may be computed using figure 2-3 or 2-4.³ CN's shown are equivalent to those of pasture. Composite CN's may be computed for other combinations of open space cover type.⁴ Composite CN's for natural desert landscaping should be computed using figures 2-3 or 2-4 based on the impervious area percentage (CN = 98) and the pervious area CN. The pervious area CN's are assumed equivalent to desert shrub in poor hydrologic condition.⁵ Composite CN's to use for the design of temporary measures during grading and construction should be computed using figure 2-3 or 2-4 based on the degree of development (impervious area percentage) and the CN's for the newly graded pervious areas.

TABLE 3.14-D

CONCENTRIC TRASH RACK AND ANTI-VORTEX DEVICE DESIGN TABLE

Riser Diam., in.	Cylinder		Height, inches	Minimum Size Support Bar	Minimum Top	
	Diameter, inches	Thickness, gage			Thickness	Stiffener
12	18	16	6	#6 Rebar or 1½ x 1½ x 3/16 angle	16 ga. (F&C)	-
15	21	16	7	" "	" "	-
18	27	16	8	" "	" "	-
21	30	16	11	" "	16 ga.(C), 14 ga.(F) -	-
24	36	16	13	" "	" "	-
27	42	16	15	" "	" "	-
36	54	14	17	#8 Rebar	14 ga.(C), 12 ga.(F)	-
42	60	16	19	" "	" "	-
48	72	16	21	1¼" pipe or 1¼ x 1¼ x ¼ angle	14 ga.(C), 10 ga.(F)	-
54	78	16	25	" "	" "	-
60	90	14	29	1½" pipe or 1½ x 1½ x ¼ angle	12 ga.(C), 8 ga.(F)	-
66	96	14	33	2" pipe or 2 x 2 x 3/16 angle	12 ga.(C), 8 ga.(F) w/stiffener	2 x 2 x ¼ angle
72	102	14	36	" "	" "	2½ x 2½ x ¼ angle
78	114	14	39	2½" pipe or 2 x 2 x ¼ angle	" "	" "
84	120	12	42	2½" pipe or 2½ x 2½ x ¼ angle	" "	2½ x 2½ x 5/16 angle

Note₁: The criterion for sizing the cylinder is that the area between the inside of the cylinder and the outside of the riser is equal to or greater than the area inside the riser. Therefore, the above table is invalid for use with concrete pipe risers.

Note₂: Corrugation for 12"-36" pipe measures 2¾" x ½"; for 42" -84" the corrugation measures 5" x 1" or 8" x 1".

Note₃: C = corrugated; F = flat.

Source: Adapted from USDA-SCS and Carl M. Henshaw Drainage Products Information.



United States
Department of
Agriculture

NRCS

Natural
Resources
Conservation
Service

A product of the National
Cooperative Soil Survey,
a joint effort of the United
States Department of
Agriculture and other
Federal agencies, State
agencies including the
Agricultural Experiment
Stations, and local
participants

Custom Soil Resource Report for **Lee County, North Carolina**

Sanford



September 16, 2014

Preface

Soil surveys contain information that affects land use planning in survey areas. They highlight soil limitations that affect various land uses and provide information about the properties of the soils in the survey areas. Soil surveys are designed for many different users, including farmers, ranchers, foresters, agronomists, urban planners, community officials, engineers, developers, builders, and home buyers. Also, conservationists, teachers, students, and specialists in recreation, waste disposal, and pollution control can use the surveys to help them understand, protect, or enhance the environment.

Various land use regulations of Federal, State, and local governments may impose special restrictions on land use or land treatment. Soil surveys identify soil properties that are used in making various land use or land treatment decisions. The information is intended to help the land users identify and reduce the effects of soil limitations on various land uses. The landowner or user is responsible for identifying and complying with existing laws and regulations.

Although soil survey information can be used for general farm, local, and wider area planning, onsite investigation is needed to supplement this information in some cases. Examples include soil quality assessments (<http://www.nrcs.usda.gov/wps/portal/nrcs/main/soils/health/>) and certain conservation and engineering applications. For more detailed information, contact your local USDA Service Center (<http://offices.sc.egov.usda.gov/locator/app?agency=nrcs>) or your NRCS State Soil Scientist (http://www.nrcs.usda.gov/wps/portal/nrcs/detail/soils/contactus/?cid=nrcs142p2_053951).

Great differences in soil properties can occur within short distances. Some soils are seasonally wet or subject to flooding. Some are too unstable to be used as a foundation for buildings or roads. Clayey or wet soils are poorly suited to use as septic tank absorption fields. A high water table makes a soil poorly suited to basements or underground installations.

The National Cooperative Soil Survey is a joint effort of the United States Department of Agriculture and other Federal agencies, State agencies including the Agricultural Experiment Stations, and local agencies. The Natural Resources Conservation Service (NRCS) has leadership for the Federal part of the National Cooperative Soil Survey.

Information about soils is updated periodically. Updated information is available through the NRCS Web Soil Survey, the site for official soil survey information.

The U.S. Department of Agriculture (USDA) prohibits discrimination in all its programs and activities on the basis of race, color, national origin, age, disability, and where applicable, sex, marital status, familial status, parental status, religion, sexual orientation, genetic information, political beliefs, reprisal, or because all or a part of an individual's income is derived from any public assistance program. (Not all prohibited bases apply to all programs.) Persons with disabilities who require alternative means

for communication of program information (Braille, large print, audiotape, etc.) should contact USDA's TARGET Center at (202) 720-2600 (voice and TDD). To file a complaint of discrimination, write to USDA, Director, Office of Civil Rights, 1400 Independence Avenue, S.W., Washington, D.C. 20250-9410 or call (800) 795-3272 (voice) or (202) 720-6382 (TDD). USDA is an equal opportunity provider and employer.

Contents

Preface	2
How Soil Surveys Are Made	5
Soil Map	7
Soil Map.....	8
Legend.....	9
Map Unit Legend.....	10
Map Unit Descriptions.....	10
Lee County, North Carolina.....	13
Ch—Chewacla silt loam, 0 to 2 percent slopes, frequently flooded.....	13
CrB—Creedmoor fine sandy loam, 2 to 8 percent slopes.....	14
CrD—Creedmoor fine sandy loam, 8 to 15 percent slopes.....	15
MfB—Mayodan fine sandy loam, 2 to 8 percent slopes.....	16
MfD—Mayodan fine sandy loam, 8 to 15 percent slopes.....	17
MfE—Mayodan fine sandy loam, 15 to 25 percent slopes.....	18
PfB—Pinkston silt loam, 2 to 8 percent slopes.....	19
PfD—Pinkston silt loam, 8 to 15 percent slopes.....	20
PfF—Pinkston silt loam, 15 to 40 percent slopes.....	21
ToB—Tillery fine sandy loam, 1 to 4 percent slopes, rarely flooded.....	22
Ud—Udorthents, loamy.....	23
W—Water.....	24
References	25

How Soil Surveys Are Made

Soil surveys are made to provide information about the soils and miscellaneous areas in a specific area. They include a description of the soils and miscellaneous areas and their location on the landscape and tables that show soil properties and limitations affecting various uses. Soil scientists observed the steepness, length, and shape of the slopes; the general pattern of drainage; the kinds of crops and native plants; and the kinds of bedrock. They observed and described many soil profiles. A soil profile is the sequence of natural layers, or horizons, in a soil. The profile extends from the surface down into the unconsolidated material in which the soil formed or from the surface down to bedrock. The unconsolidated material is devoid of roots and other living organisms and has not been changed by other biological activity.

Currently, soils are mapped according to the boundaries of major land resource areas (MLRAs). MLRAs are geographically associated land resource units that share common characteristics related to physiography, geology, climate, water resources, soils, biological resources, and land uses (USDA, 2006). Soil survey areas typically consist of parts of one or more MLRA.

The soils and miscellaneous areas in a survey area occur in an orderly pattern that is related to the geology, landforms, relief, climate, and natural vegetation of the area. Each kind of soil and miscellaneous area is associated with a particular kind of landform or with a segment of the landform. By observing the soils and miscellaneous areas in the survey area and relating their position to specific segments of the landform, a soil scientist develops a concept, or model, of how they were formed. Thus, during mapping, this model enables the soil scientist to predict with a considerable degree of accuracy the kind of soil or miscellaneous area at a specific location on the landscape.

Commonly, individual soils on the landscape merge into one another as their characteristics gradually change. To construct an accurate soil map, however, soil scientists must determine the boundaries between the soils. They can observe only a limited number of soil profiles. Nevertheless, these observations, supplemented by an understanding of the soil-vegetation-landscape relationship, are sufficient to verify predictions of the kinds of soil in an area and to determine the boundaries.

Soil scientists recorded the characteristics of the soil profiles that they studied. They noted soil color, texture, size and shape of soil aggregates, kind and amount of rock fragments, distribution of plant roots, reaction, and other features that enable them to identify soils. After describing the soils in the survey area and determining their properties, the soil scientists assigned the soils to taxonomic classes (units). Taxonomic classes are concepts. Each taxonomic class has a set of soil characteristics with precisely defined limits. The classes are used as a basis for comparison to classify soils systematically. Soil taxonomy, the system of taxonomic classification used in the United States, is based mainly on the kind and character of soil properties and the arrangement of horizons within the profile. After the soil scientists classified and named the soils in the survey area, they compared the

Custom Soil Resource Report

individual soils with similar soils in the same taxonomic class in other areas so that they could confirm data and assemble additional data based on experience and research.

The objective of soil mapping is not to delineate pure map unit components; the objective is to separate the landscape into landforms or landform segments that have similar use and management requirements. Each map unit is defined by a unique combination of soil components and/or miscellaneous areas in predictable proportions. Some components may be highly contrasting to the other components of the map unit. The presence of minor components in a map unit in no way diminishes the usefulness or accuracy of the data. The delineation of such landforms and landform segments on the map provides sufficient information for the development of resource plans. If intensive use of small areas is planned, onsite investigation is needed to define and locate the soils and miscellaneous areas.

Soil scientists make many field observations in the process of producing a soil map. The frequency of observation is dependent upon several factors, including scale of mapping, intensity of mapping, design of map units, complexity of the landscape, and experience of the soil scientist. Observations are made to test and refine the soil-landscape model and predictions and to verify the classification of the soils at specific locations. Once the soil-landscape model is refined, a significantly smaller number of measurements of individual soil properties are made and recorded. These measurements may include field measurements, such as those for color, depth to bedrock, and texture, and laboratory measurements, such as those for content of sand, silt, clay, salt, and other components. Properties of each soil typically vary from one point to another across the landscape.

Observations for map unit components are aggregated to develop ranges of characteristics for the components. The aggregated values are presented. Direct measurements do not exist for every property presented for every map unit component. Values for some properties are estimated from combinations of other properties.

While a soil survey is in progress, samples of some of the soils in the area generally are collected for laboratory analyses and for engineering tests. Soil scientists interpret the data from these analyses and tests as well as the field-observed characteristics and the soil properties to determine the expected behavior of the soils under different uses. Interpretations for all of the soils are field tested through observation of the soils in different uses and under different levels of management. Some interpretations are modified to fit local conditions, and some new interpretations are developed to meet local needs. Data are assembled from other sources, such as research information, production records, and field experience of specialists. For example, data on crop yields under defined levels of management are assembled from farm records and from field or plot experiments on the same kinds of soil.

Predictions about soil behavior are based not only on soil properties but also on such variables as climate and biological activity. Soil conditions are predictable over long periods of time, but they are not predictable from year to year. For example, soil scientists can predict with a fairly high degree of accuracy that a given soil will have a high water table within certain depths in most years, but they cannot predict that a high water table will always be at a specific level in the soil on a specific date.

After soil scientists located and identified the significant natural bodies of soil in the survey area, they drew the boundaries of these bodies on aerial photographs and identified each as a specific map unit. Aerial photographs show trees, buildings, fields, roads, and rivers, all of which help in locating boundaries accurately.

Soil Map

The soil map section includes the soil map for the defined area of interest, a list of soil map units on the map and extent of each map unit, and cartographic symbols displayed on the map. Also presented are various metadata about data used to produce the map, and a description of each soil map unit.

Custom Soil Resource Report Soil Map



Map Scale: 1:14,700 if printed on A landscape (11" x 8.5") sheet.

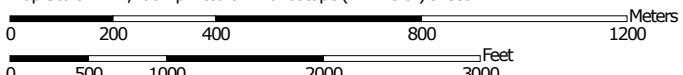

Map projection: Web Mercator Corner coordinates: WGS84 Edge tics: UTM Zone 17N WGS84

MAP LEGEND

Area of Interest (AOI)

 Area of Interest (AOI)

Soils

 Soil Map Unit Polygons

 Soil Map Unit Lines

 Soil Map Unit Points

Special Point Features

 Blowout

 Borrow Pit

 Clay Spot

 Closed Depression

 Gravel Pit

 Gravelly Spot

 Landfill

 Lava Flow

 Marsh or swamp

 Mine or Quarry

 Miscellaneous Water

 Perennial Water

 Rock Outcrop

 Saline Spot

 Sandy Spot

 Severely Eroded Spot

 Sinkhole

 Slide or Slip

 Sodic Spot

 Spoil Area

 Stony Spot

 Very Stony Spot

 Wet Spot

 Other

 Special Line Features

Water Features

 Streams and Canals

Transportation

 Rails

 Interstate Highways

 US Routes

 Major Roads

 Local Roads

Background

 Aerial Photography

MAP INFORMATION

The soil surveys that comprise your AOI were mapped at 1:24,000.

Warning: Soil Map may not be valid at this scale.

Enlargement of maps beyond the scale of mapping can cause misunderstanding of the detail of mapping and accuracy of soil line placement. The maps do not show the small areas of contrasting soils that could have been shown at a more detailed scale.

Please rely on the bar scale on each map sheet for map measurements.

Source of Map: Natural Resources Conservation Service
 Web Soil Survey URL: <http://websoilsurvey.nrcs.usda.gov>
 Coordinate System: Web Mercator (EPSG:3857)

Maps from the Web Soil Survey are based on the Web Mercator projection, which preserves direction and shape but distorts distance and area. A projection that preserves area, such as the Albers equal-area conic projection, should be used if more accurate calculations of distance or area are required.

This product is generated from the USDA-NRCS certified data as of the version date(s) listed below.

Soil Survey Area: Lee County, North Carolina
 Survey Area Data: Version 11, Dec 16, 2013

Soil map units are labeled (as space allows) for map scales 1:50,000 or larger.

Date(s) aerial images were photographed: Feb 11, 2011—Apr 2, 2011

The orthophoto or other base map on which the soil lines were compiled and digitized probably differs from the background imagery displayed on these maps. As a result, some minor shifting of map unit boundaries may be evident.

Map Unit Legend

Lee County, North Carolina (NC105)			
Map Unit Symbol	Map Unit Name	Acres in AOI	Percent of AOI
Ch	Chewacla silt loam, 0 to 2 percent slopes, frequently flooded	144.6	13.2%
CrB	Creedmoor fine sandy loam, 2 to 8 percent slopes	101.3	9.3%
CrD	Creedmoor fine sandy loam, 8 to 15 percent slopes	24.5	2.2%
MfB	Mayodan fine sandy loam, 2 to 8 percent slopes	344.6	31.6%
MfD	Mayodan fine sandy loam, 8 to 15 percent slopes	205.8	18.9%
MfE	Mayodan fine sandy loam, 15 to 25 percent slopes	50.6	4.6%
PfB	Pinkston silt loam, 2 to 8 percent slopes	17.6	1.6%
PfD	Pinkston silt loam, 8 to 15 percent slopes	76.9	7.0%
PfF	Pinkston silt loam, 15 to 40 percent slopes	104.9	9.6%
ToB	Tillery fine sandy loam, 1 to 4 percent slopes, rarely flooded	14.5	1.3%
Ud	Udorthents, loamy	4.4	0.4%
W	Water	1.9	0.2%
Totals for Area of Interest		1,091.4	100.0%

Map Unit Descriptions

The map units delineated on the detailed soil maps in a soil survey represent the soils or miscellaneous areas in the survey area. The map unit descriptions, along with the maps, can be used to determine the composition and properties of a unit.

A map unit delineation on a soil map represents an area dominated by one or more major kinds of soil or miscellaneous areas. A map unit is identified and named according to the taxonomic classification of the dominant soils. Within a taxonomic class there are precisely defined limits for the properties of the soils. On the landscape, however, the soils are natural phenomena, and they have the characteristic variability of all natural phenomena. Thus, the range of some observed properties may extend beyond the limits defined for a taxonomic class. Areas of soils of a single taxonomic class rarely, if ever, can be mapped without including areas of other taxonomic classes. Consequently, every map unit is made up of the soils or miscellaneous areas for which it is named and some minor components that belong to taxonomic classes other than those of the major soils.

Custom Soil Resource Report

Most minor soils have properties similar to those of the dominant soil or soils in the map unit, and thus they do not affect use and management. These are called noncontrasting, or similar, components. They may or may not be mentioned in a particular map unit description. Other minor components, however, have properties and behavioral characteristics divergent enough to affect use or to require different management. These are called contrasting, or dissimilar, components. They generally are in small areas and could not be mapped separately because of the scale used. Some small areas of strongly contrasting soils or miscellaneous areas are identified by a special symbol on the maps. If included in the database for a given area, the contrasting minor components are identified in the map unit descriptions along with some characteristics of each. A few areas of minor components may not have been observed, and consequently they are not mentioned in the descriptions, especially where the pattern was so complex that it was impractical to make enough observations to identify all the soils and miscellaneous areas on the landscape.

The presence of minor components in a map unit in no way diminishes the usefulness or accuracy of the data. The objective of mapping is not to delineate pure taxonomic classes but rather to separate the landscape into landforms or landform segments that have similar use and management requirements. The delineation of such segments on the map provides sufficient information for the development of resource plans. If intensive use of small areas is planned, however, onsite investigation is needed to define and locate the soils and miscellaneous areas.

An identifying symbol precedes the map unit name in the map unit descriptions. Each description includes general facts about the unit and gives important soil properties and qualities.

Soils that have profiles that are almost alike make up a *soil series*. Except for differences in texture of the surface layer, all the soils of a series have major horizons that are similar in composition, thickness, and arrangement.

Soils of one series can differ in texture of the surface layer, slope, stoniness, salinity, degree of erosion, and other characteristics that affect their use. On the basis of such differences, a soil series is divided into *soil phases*. Most of the areas shown on the detailed soil maps are phases of soil series. The name of a soil phase commonly indicates a feature that affects use or management. For example, Alpha silt loam, 0 to 2 percent slopes, is a phase of the Alpha series.

Some map units are made up of two or more major soils or miscellaneous areas. These map units are complexes, associations, or undifferentiated groups.

A *complex* consists of two or more soils or miscellaneous areas in such an intricate pattern or in such small areas that they cannot be shown separately on the maps. The pattern and proportion of the soils or miscellaneous areas are somewhat similar in all areas. Alpha-Beta complex, 0 to 6 percent slopes, is an example.

An *association* is made up of two or more geographically associated soils or miscellaneous areas that are shown as one unit on the maps. Because of present or anticipated uses of the map units in the survey area, it was not considered practical or necessary to map the soils or miscellaneous areas separately. The pattern and relative proportion of the soils or miscellaneous areas are somewhat similar. Alpha-Beta association, 0 to 2 percent slopes, is an example.

An *undifferentiated group* is made up of two or more soils or miscellaneous areas that could be mapped individually but are mapped as one unit because similar interpretations can be made for use and management. The pattern and proportion of the soils or miscellaneous areas in a mapped area are not uniform. An area can be

Custom Soil Resource Report

made up of only one of the major soils or miscellaneous areas, or it can be made up of all of them. Alpha and Beta soils, 0 to 2 percent slopes, is an example.

Some surveys include *miscellaneous areas*. Such areas have little or no soil material and support little or no vegetation. Rock outcrop is an example.

Lee County, North Carolina

Ch—Chewacla silt loam, 0 to 2 percent slopes, frequently flooded

Map Unit Setting

National map unit symbol: 2mz3q

Elevation: 200 to 1,400 feet

Mean annual precipitation: 37 to 60 inches

Mean annual air temperature: 59 to 66 degrees F

Frost-free period: 200 to 240 days

Farmland classification: Prime farmland if drained and either protected from flooding or not frequently flooded during the growing season

Map Unit Composition

Chewacla and similar soils: 87 percent

Minor components: 13 percent

Estimates are based on observations, descriptions, and transects of the mapunit.

Description of Chewacla

Setting

Landform: Flood plains

Down-slope shape: Concave

Across-slope shape: Linear

Parent material: Loamy alluvium derived from igneous and metamorphic rock

Typical profile

A - 0 to 4 inches: silt loam

Bw1 - 4 to 26 inches: silty clay loam

Bw2 - 26 to 38 inches: loam

Bw3 - 38 to 60 inches: clay loam

C - 60 to 80 inches: loam

Properties and qualities

Slope: 0 to 2 percent

Depth to restrictive feature: More than 80 inches

Natural drainage class: Somewhat poorly drained

Runoff class: Low

Capacity of the most limiting layer to transmit water (Ksat): Moderately high to high
(0.57 to 1.98 in/hr)

Depth to water table: About 6 to 24 inches

Frequency of flooding: Frequent

Frequency of ponding: None

Available water storage in profile: High (about 11.5 inches)

Interpretive groups

Land capability classification (irrigated): None specified

Land capability classification (nonirrigated): 4w

Hydrologic Soil Group: B/D

Minor Components

Congaree

Percent of map unit: 8 percent

Landform: Flood plains

Down-slope shape: Linear

Across-slope shape: Linear

Wehadkee, undrained

Percent of map unit: 5 percent

Landform: Depressions on flood plains

Down-slope shape: Concave

Across-slope shape: Linear

CrB—Creedmoor fine sandy loam, 2 to 8 percent slopes

Map Unit Setting

National map unit symbol: 3t5w

Elevation: 200 to 1,400 feet

Mean annual precipitation: 37 to 60 inches

Mean annual air temperature: 59 to 66 degrees F

Frost-free period: 200 to 240 days

Farmland classification: All areas are prime farmland

Map Unit Composition

Creedmoor and similar soils: 90 percent

Minor components: 8 percent

Estimates are based on observations, descriptions, and transects of the mapunit.

Description of Creedmoor

Setting

Landform: Interfluves

Landform position (two-dimensional): Summit

Landform position (three-dimensional): Interfluve

Down-slope shape: Convex

Across-slope shape: Convex

Parent material: Residuum weathered from shale and siltstone and/or mudstone and/or sandstone

Typical profile

Ap - 0 to 14 inches: fine sandy loam

Bt1 - 14 to 29 inches: silty clay loam

Bt2 - 29 to 56 inches: silty clay

BCg - 56 to 72 inches: loam

Cr - 72 to 96 inches: weathered bedrock

Properties and qualities

Slope: 2 to 8 percent

Depth to restrictive feature: 72 to 100 inches to paralithic bedrock

Natural drainage class: Moderately well drained

Runoff class: High

Capacity of the most limiting layer to transmit water (Ksat): Very low to moderately low (0.00 to 0.06 in/hr)

Depth to water table: About 18 to 24 inches

Frequency of flooding: None

Frequency of ponding: None

Custom Soil Resource Report

Sodium adsorption ratio, maximum in profile: 13.0
Available water storage in profile: Moderate (about 8.0 inches)

Interpretive groups

Land capability classification (irrigated): None specified
Land capability classification (nonirrigated): 2e
Hydrologic Soil Group: C/D

Minor Components

Mayodan

Percent of map unit: 8 percent
Landform: Interfluves
Landform position (two-dimensional): Summit
Landform position (three-dimensional): Interfluve
Down-slope shape: Convex
Across-slope shape: Convex

CrD—Creedmoor fine sandy loam, 8 to 15 percent slopes

Map Unit Setting

National map unit symbol: 3t5x
Elevation: 200 to 1,400 feet
Mean annual precipitation: 37 to 60 inches
Mean annual air temperature: 59 to 66 degrees F
Frost-free period: 200 to 240 days
Farmland classification: Farmland of statewide importance

Map Unit Composition

Creedmoor and similar soils: 85 percent
Estimates are based on observations, descriptions, and transects of the mapunit.

Description of Creedmoor

Setting

Landform: Hillslopes on ridges
Landform position (two-dimensional): Backslope
Landform position (three-dimensional): Side slope
Down-slope shape: Linear
Across-slope shape: Convex
Parent material: Residuum weathered from shale and siltstone and/or mudstone and/or sandstone

Typical profile

Ap - 0 to 14 inches: fine sandy loam
Bt1 - 14 to 29 inches: silty clay loam
Bt2 - 29 to 56 inches: silty clay
BCg - 56 to 72 inches: loam
Cr - 72 to 96 inches: weathered bedrock
R - 96 to 100 inches: unweathered bedrock

Custom Soil Resource Report

Properties and qualities

Slope: 8 to 15 percent

Depth to restrictive feature: 72 to 100 inches to paralithic bedrock

Natural drainage class: Moderately well drained

Runoff class: High

Capacity of the most limiting layer to transmit water (Ksat): Very low to moderately low (0.00 to 0.06 in/hr)

Depth to water table: About 18 to 24 inches

Frequency of flooding: None

Frequency of ponding: None

Sodium adsorption ratio, maximum in profile: 13.0

Available water storage in profile: Moderate (about 8.0 inches)

Interpretive groups

Land capability classification (irrigated): None specified

Land capability classification (nonirrigated): 3e

Hydrologic Soil Group: C/D

MfB—Mayodan fine sandy loam, 2 to 8 percent slopes

Map Unit Setting

National map unit symbol: 3t64

Elevation: 200 to 1,400 feet

Mean annual precipitation: 37 to 60 inches

Mean annual air temperature: 59 to 66 degrees F

Frost-free period: 200 to 240 days

Farmland classification: All areas are prime farmland

Map Unit Composition

Mayodan and similar soils: 85 percent

Estimates are based on observations, descriptions, and transects of the mapunit.

Description of Mayodan

Setting

Landform: Interfluves

Landform position (two-dimensional): Summit

Landform position (three-dimensional): Interfluve

Down-slope shape: Convex

Across-slope shape: Convex

Parent material: Residuum weathered from mudstone and/or shale and siltstone and/or sandstone

Typical profile

Ap - 0 to 6 inches: fine sandy loam

BE - 6 to 9 inches: sandy clay loam

Bt - 9 to 33 inches: clay

BC - 33 to 40 inches: sandy clay loam

C - 40 to 80 inches: sandy clay loam

Properties and qualities

Slope: 2 to 8 percent

Custom Soil Resource Report

Depth to restrictive feature: More than 80 inches
Natural drainage class: Well drained
Runoff class: Medium
Capacity of the most limiting layer to transmit water (Ksat): Moderately high to high
(0.57 to 1.98 in/hr)
Depth to water table: More than 80 inches
Frequency of flooding: None
Frequency of ponding: None
Sodium adsorption ratio, maximum in profile: 7.0
Available water storage in profile: High (about 9.3 inches)

Interpretive groups

Land capability classification (irrigated): None specified
Land capability classification (nonirrigated): 2e
Hydrologic Soil Group: B

MfD—Mayodan fine sandy loam, 8 to 15 percent slopes

Map Unit Setting

National map unit symbol: 3t65
Elevation: 200 to 1,400 feet
Mean annual precipitation: 37 to 60 inches
Mean annual air temperature: 59 to 66 degrees F
Frost-free period: 200 to 240 days
Farmland classification: Farmland of statewide importance

Map Unit Composition

Mayodan and similar soils: 85 percent
Estimates are based on observations, descriptions, and transects of the mapunit.

Description of Mayodan

Setting

Landform: Hillslopes on ridges
Landform position (two-dimensional): Backslope
Landform position (three-dimensional): Side slope
Down-slope shape: Linear
Across-slope shape: Convex
Parent material: Residuum weathered from mudstone and/or shale and siltstone
and/or sandstone

Typical profile

Ap - 0 to 6 inches: fine sandy loam
BE - 6 to 9 inches: sandy clay loam
Bt - 9 to 33 inches: clay
BC - 33 to 40 inches: sandy clay loam
C - 40 to 80 inches: sandy clay loam

Properties and qualities

Slope: 8 to 15 percent
Depth to restrictive feature: More than 80 inches
Natural drainage class: Well drained

Custom Soil Resource Report

Runoff class: Medium

Capacity of the most limiting layer to transmit water (Ksat): Moderately high to high
(0.57 to 1.98 in/hr)

Depth to water table: More than 80 inches

Frequency of flooding: None

Frequency of ponding: None

Sodium adsorption ratio, maximum in profile: 7.0

Available water storage in profile: High (about 9.3 inches)

Interpretive groups

Land capability classification (irrigated): None specified

Land capability classification (nonirrigated): 3e

Hydrologic Soil Group: B

MfE—Mayodan fine sandy loam, 15 to 25 percent slopes

Map Unit Setting

National map unit symbol: 3t66

Elevation: 200 to 1,400 feet

Mean annual precipitation: 37 to 60 inches

Mean annual air temperature: 59 to 66 degrees F

Frost-free period: 200 to 240 days

Farmland classification: Not prime farmland

Map Unit Composition

Mayodan and similar soils: 80 percent

Estimates are based on observations, descriptions, and transects of the mapunit.

Description of Mayodan

Setting

Landform: Hillslopes on ridges

Landform position (two-dimensional): Backslope

Landform position (three-dimensional): Side slope

Down-slope shape: Linear

Across-slope shape: Convex

Parent material: Residuum weathered from mudstone and/or shale and siltstone
and/or sandstone

Typical profile

Ap - 0 to 6 inches: fine sandy loam

BE - 6 to 9 inches: sandy clay loam

Bt - 9 to 33 inches: clay

BC - 33 to 40 inches: sandy clay loam

C - 40 to 80 inches: sandy clay loam

Properties and qualities

Slope: 15 to 25 percent

Depth to restrictive feature: More than 80 inches

Natural drainage class: Well drained

Runoff class: High

Custom Soil Resource Report

Capacity of the most limiting layer to transmit water (Ksat): Moderately high to high
(0.57 to 1.98 in/hr)

Depth to water table: More than 80 inches

Frequency of flooding: None

Frequency of ponding: None

Sodium adsorption ratio, maximum in profile: 7.0

Available water storage in profile: High (about 9.3 inches)

Interpretive groups

Land capability classification (irrigated): None specified

Land capability classification (nonirrigated): 4e

Hydrologic Soil Group: B

PfB—Pinkston silt loam, 2 to 8 percent slopes

Map Unit Setting

National map unit symbol: 3t6c

Elevation: 200 to 1,400 feet

Mean annual precipitation: 37 to 60 inches

Mean annual air temperature: 59 to 66 degrees F

Frost-free period: 200 to 240 days

Farmland classification: Not prime farmland

Map Unit Composition

Pinkston and similar soils: 90 percent

Estimates are based on observations, descriptions, and transects of the mapunit.

Description of Pinkston

Setting

Landform: Interfluves

Landform position (two-dimensional): Summit

Landform position (three-dimensional): Interfluve

Down-slope shape: Convex

Across-slope shape: Convex

Parent material: Residuum weathered from mudstone and/or shale and siltstone
and/or sandstone

Typical profile

A - 0 to 6 inches: silt loam

Bw - 6 to 16 inches: silt loam

C - 16 to 38 inches: silt loam

R - 38 to 80 inches: unweathered bedrock

Properties and qualities

Slope: 2 to 8 percent

Depth to restrictive feature: 20 to 40 inches to lithic bedrock

Natural drainage class: Well drained

Runoff class: High

Capacity of the most limiting layer to transmit water (Ksat): Very low to moderately
low (0.00 to 0.06 in/hr)

Depth to water table: More than 80 inches

Custom Soil Resource Report

Frequency of flooding: None
Frequency of ponding: None
Sodium adsorption ratio, maximum in profile: 13.0
Available water storage in profile: Low (about 4.5 inches)

Interpretive groups

Land capability classification (irrigated): None specified
Land capability classification (nonirrigated): 3e
Hydrologic Soil Group: C

PfD—Pinkston silt loam, 8 to 15 percent slopes

Map Unit Setting

National map unit symbol: 3t6d
Elevation: 200 to 1,400 feet
Mean annual precipitation: 37 to 60 inches
Mean annual air temperature: 59 to 66 degrees F
Frost-free period: 200 to 240 days
Farmland classification: Not prime farmland

Map Unit Composition

Pinkston and similar soils: 85 percent
Estimates are based on observations, descriptions, and transects of the mapunit.

Description of Pinkston

Setting

Landform: Hillslopes on ridges
Landform position (two-dimensional): Backslope
Landform position (three-dimensional): Side slope
Down-slope shape: Linear
Across-slope shape: Convex
Parent material: Residuum weathered from mudstone and/or shale and siltstone and/or sandstone

Typical profile

A - 0 to 6 inches: silt loam
Bw - 6 to 16 inches: silt loam
C - 16 to 38 inches: silt loam
R - 38 to 80 inches: unweathered bedrock

Properties and qualities

Slope: 8 to 15 percent
Depth to restrictive feature: 20 to 40 inches to lithic bedrock
Natural drainage class: Well drained
Runoff class: High
Capacity of the most limiting layer to transmit water (Ksat): Very low to moderately low (0.00 to 0.06 in/hr)
Depth to water table: More than 80 inches
Frequency of flooding: None
Frequency of ponding: None
Sodium adsorption ratio, maximum in profile: 13.0

Custom Soil Resource Report

Available water storage in profile: Low (about 4.5 inches)

Interpretive groups

Land capability classification (irrigated): None specified

Land capability classification (nonirrigated): 4e

Hydrologic Soil Group: C

PfF—Pinkston silt loam, 15 to 40 percent slopes

Map Unit Setting

National map unit symbol: 3t6f

Elevation: 200 to 1,400 feet

Mean annual precipitation: 37 to 60 inches

Mean annual air temperature: 59 to 66 degrees F

Frost-free period: 200 to 240 days

Farmland classification: Not prime farmland

Map Unit Composition

Pinkston and similar soils: 80 percent

Estimates are based on observations, descriptions, and transects of the mapunit.

Description of Pinkston

Setting

Landform: Hillslopes on ridges

Landform position (two-dimensional): Backslope

Landform position (three-dimensional): Side slope

Down-slope shape: Linear

Across-slope shape: Convex

Parent material: Residuum weathered from mudstone and/or shale and siltstone and/or sandstone

Typical profile

A - 0 to 6 inches: silt loam

Bw - 6 to 16 inches: silt loam

C - 16 to 38 inches: silt loam

R - 38 to 80 inches: unweathered bedrock

Properties and qualities

Slope: 15 to 40 percent

Depth to restrictive feature: 20 to 40 inches to lithic bedrock

Natural drainage class: Well drained

Runoff class: Very high

Capacity of the most limiting layer to transmit water (Ksat): Very low to moderately low (0.00 to 0.06 in/hr)

Depth to water table: More than 80 inches

Frequency of flooding: None

Frequency of ponding: None

Sodium adsorption ratio, maximum in profile: 13.0

Available water storage in profile: Low (about 4.5 inches)

Interpretive groups

Land capability classification (irrigated): None specified

Custom Soil Resource Report

Land capability classification (nonirrigated): 6e
Hydrologic Soil Group: C

ToB—Tillery fine sandy loam, 1 to 4 percent slopes, rarely flooded

Map Unit Setting

National map unit symbol: 2ml49
Elevation: 200 to 1,400 feet
Mean annual precipitation: 37 to 60 inches
Mean annual air temperature: 59 to 66 degrees F
Frost-free period: 200 to 240 days
Farmland classification: All areas are prime farmland

Map Unit Composition

Tillery and similar soils: 90 percent
Estimates are based on observations, descriptions, and transects of the mapunit.

Description of Tillery

Setting

Landform: Stream terraces
Down-slope shape: Linear
Across-slope shape: Linear
Parent material: Loamy alluvium derived from igneous and metamorphic rock

Typical profile

Ap - 0 to 7 inches: fine sandy loam
Bt - 7 to 48 inches: silty clay loam
Cg - 48 to 80 inches: silt loam

Properties and qualities

Slope: 1 to 4 percent
Depth to restrictive feature: More than 80 inches
Natural drainage class: Moderately well drained
Runoff class: Low
Capacity of the most limiting layer to transmit water (Ksat): Moderately high to high
(0.57 to 1.98 in/hr)
Depth to water table: About 18 to 30 inches
Frequency of flooding: Rare
Frequency of ponding: None
Available water storage in profile: Moderate (about 8.9 inches)

Interpretive groups

Land capability classification (irrigated): None specified
Land capability classification (nonirrigated): 2e
Hydrologic Soil Group: C

Ud—Udorthents, loamy

Map Unit Setting

National map unit symbol: 3t6p
Elevation: 200 to 1,400 feet
Mean annual precipitation: 37 to 60 inches
Mean annual air temperature: 50 to 66 degrees F
Frost-free period: 145 to 240 days
Farmland classification: Not prime farmland

Map Unit Composition

Udorthents, loamy, and similar soils: 85 percent
Minor components: 8 percent
Estimates are based on observations, descriptions, and transects of the mapunit.

Description of Udorthents, Loamy

Setting

Landform: Hillslopes on ridges
Landform position (two-dimensional): Shoulder, summit, backslope
Landform position (three-dimensional): Side slope
Down-slope shape: Linear
Across-slope shape: Convex
Parent material: Loamy and clayey human transported material derived from igneous, metamorphic and sedimentary rock

Typical profile

C - 0 to 80 inches: sandy clay loam

Properties and qualities

Slope: 0 to 25 percent
Depth to restrictive feature: More than 80 inches
Natural drainage class: Well drained
Runoff class: Medium
Capacity of the most limiting layer to transmit water (Ksat): Very low to high (0.00 to 1.98 in/hr)
Depth to water table: More than 80 inches
Frequency of flooding: None
Frequency of ponding: None
Available water storage in profile: Moderate (about 8.4 inches)

Interpretive groups

Land capability classification (irrigated): None specified
Land capability classification (nonirrigated): 7e
Hydrologic Soil Group: C

Minor Components

Urban land

Percent of map unit: 8 percent
Landform: Hillslopes on ridges
Landform position (two-dimensional): Summit, shoulder, backslope

Custom Soil Resource Report

Landform position (three-dimensional): Side slope
Down-slope shape: Linear
Across-slope shape: Convex

W—Water

Map Unit Composition

Water: 100 percent

Estimates are based on observations, descriptions, and transects of the mapunit.

Description of Water

Interpretive groups

Land capability classification (irrigated): None specified

Land capability classification (nonirrigated): 8w

References

American Association of State Highway and Transportation Officials (AASHTO). 2004. Standard specifications for transportation materials and methods of sampling and testing. 24th edition.

American Society for Testing and Materials (ASTM). 2005. Standard classification of soils for engineering purposes. ASTM Standard D2487-00.

Cowardin, L.M., V. Carter, F.C. Golet, and E.T. LaRoe. 1979. Classification of wetlands and deep-water habitats of the United States. U.S. Fish and Wildlife Service FWS/OBS-79/31.

Federal Register. July 13, 1994. Changes in hydric soils of the United States.

Federal Register. September 18, 2002. Hydric soils of the United States.

Hurt, G.W., and L.M. Vasilas, editors. Version 6.0, 2006. Field indicators of hydric soils in the United States.

National Research Council. 1995. Wetlands: Characteristics and boundaries.

Soil Survey Division Staff. 1993. Soil survey manual. Soil Conservation Service. U.S. Department of Agriculture Handbook 18. http://www.nrcs.usda.gov/wps/portal/nrcs/detail/national/soils/?cid=nrcs142p2_054262

Soil Survey Staff. 1999. Soil taxonomy: A basic system of soil classification for making and interpreting soil surveys. 2nd edition. Natural Resources Conservation Service, U.S. Department of Agriculture Handbook 436. http://www.nrcs.usda.gov/wps/portal/nrcs/detail/national/soils/?cid=nrcs142p2_053577

Soil Survey Staff. 2010. Keys to soil taxonomy. 11th edition. U.S. Department of Agriculture, Natural Resources Conservation Service. http://www.nrcs.usda.gov/wps/portal/nrcs/detail/national/soils/?cid=nrcs142p2_053580

Tiner, R.W., Jr. 1985. Wetlands of Delaware. U.S. Fish and Wildlife Service and Delaware Department of Natural Resources and Environmental Control, Wetlands Section.

United States Army Corps of Engineers, Environmental Laboratory. 1987. Corps of Engineers wetlands delineation manual. Waterways Experiment Station Technical Report Y-87-1.

United States Department of Agriculture, Natural Resources Conservation Service. National forestry manual. http://www.nrcs.usda.gov/wps/portal/nrcs/detail/soils/home/?cid=nrcs142p2_053374

United States Department of Agriculture, Natural Resources Conservation Service. National range and pasture handbook. <http://www.nrcs.usda.gov/wps/portal/nrcs/detail/national/landuse/rangepasture/?cid=stelprdb1043084>

Custom Soil Resource Report

United States Department of Agriculture, Natural Resources Conservation Service. National soil survey handbook, title 430-VI. http://www.nrcs.usda.gov/wps/portal/nrcs/detail/soils/scientists/?cid=nrcs142p2_054242

United States Department of Agriculture, Natural Resources Conservation Service. 2006. Land resource regions and major land resource areas of the United States, the Caribbean, and the Pacific Basin. U.S. Department of Agriculture Handbook 296. http://www.nrcs.usda.gov/wps/portal/nrcs/detail/national/soils/?cid=nrcs142p2_053624

United States Department of Agriculture, Soil Conservation Service. 1961. Land capability classification. U.S. Department of Agriculture Handbook 210. http://www.nrcs.usda.gov/Internet/FSE_DOCUMENTS/nrcs142p2_052290.pdf

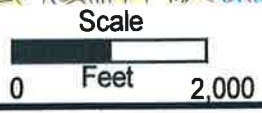
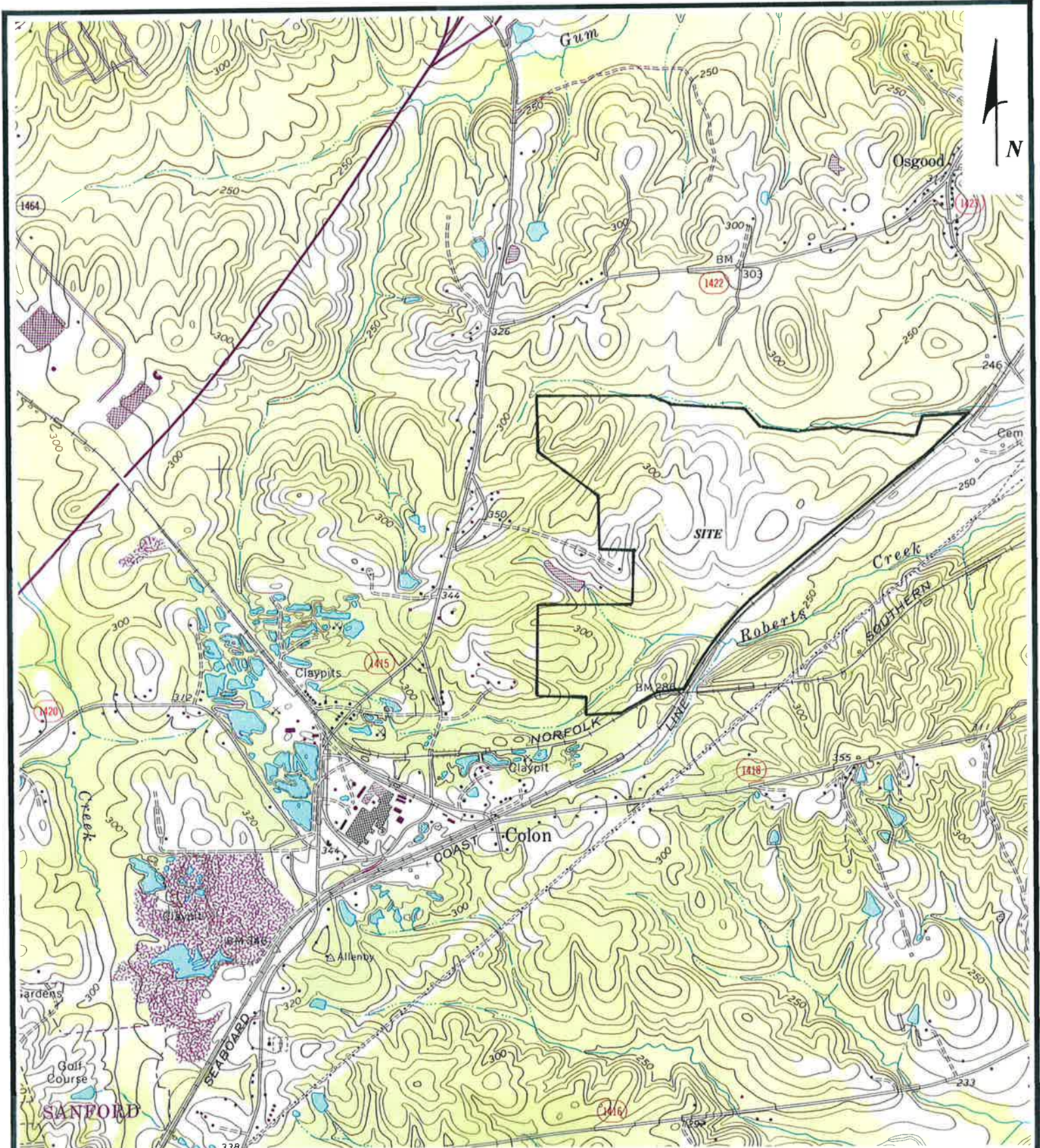

Source: 1970 USGS Colon, NC
Topographic Quadrangle

Colon Mine Reclamation Fill Site
1303 Brickyard Road
Sanford, North Carolina

Buxton Environmental, Inc.

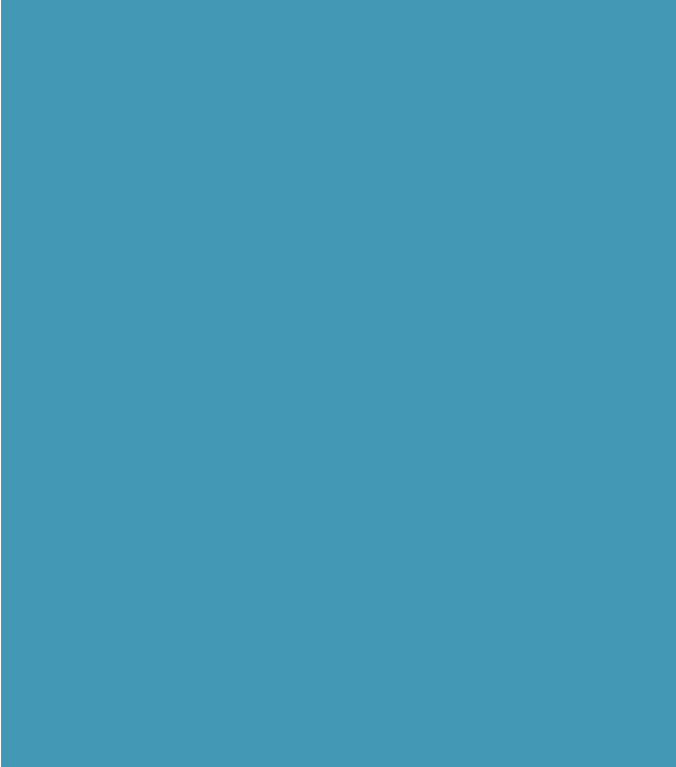
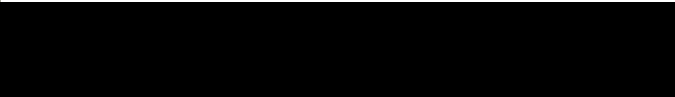

Figure 1.
Site Location Map

This page intentionally left blank.



F

Earthwork



Earthwork Calculations
Reclamation Timeline



This page intentionally left blank

HDR Computation

Project Charah Colon Mine	Computed MDP	Date 12/29/2014
Subject Permit Application	Checked JCR	Date 1/4/2015
Task Earthwork Calculations	Sheet 1	Of 3

Objective:

Determine the structural fill capacity and soil requirements

Inputs/Assumptions:

Overbuild : 0.1 ft (assumed overbuild for all soil layers)
12 in per ft
43,560 sf per acre
27 cf per cy

Calculations:

Area of Structural Fill Footprint : 5,155,867 sf (source: AutoCAD from PAW on Nov. 5, 2014 - measured from the construction baseline)

Area of Structural Fill Footprint (to use in calculations) :	118.4 acres
---	-------------

Available Airspace Capacity for Ash Placement :	7,249,796 cy	(from top of liner to top of CCP) (Source: AutoCAD from JEG on 1/04/15)
--	--------------	--

Earthwork

Cut to get to basegrades : 1,835,159 cy (Source: AutoCAD from JEG on 1/04/15)

Fill to get to basegrades : 252,722 cy (Source: AutoCAD from JEG on 1/04/15)

Soil Remaining after completing basegrades:	1,582,437 cy
--	--------------

Base Liner System

Base Liner System Thickness : 18 in

Base Liner System Volume : 305,533 cy

Cap Area

(2D area, which disregards additional area due to slope)

Top of Structural Fill Area - North Side: 2,952,700 sf (source: AutoCAD from JEG on Oct. 23, 2014)

Top of Structural Fill Area - South Side: 439,609 sf (source: AutoCAD from JEG on Oct. 23, 2014)

Top of Structural Fill Area : 77.9 acres

Side Slopes of Structural Fill Area : 40.5 acres

HDR Computation

Project Charah Colon Mine	Computed MDP	Date 12/29/2014
Subject Permit Application	Checked JCR	Date 1/4/2015
Task Earthwork Calculations	Sheet 2	Of 3

Option 1: Cap System Soil and Geomembrane (no Geocomposite Drainage Layer)

See drawings for soil permeability requirements

Topsoil Thickness :	6 in
Topsoil Area :	118.4 acres
Topsoil Volume :	114,575 cy
Low Permeable Soil Thickness :	12 in
Low Permeable Soil Area :	118.4 acres
Low Permeable Soil Volume :	210,054 cy
Top Unclassified Soil Thickness :	24 in
Top Unclassified Soil Area :	77.9 acres
Top Unclassified Soil Volume :	263,846 cy
Side Slope Unclassified Soil Thickness :	12 in
Side Slope Unclassified Soil Area :	40.5 acres
Side Slope Unclassified Soil Volume :	71,849 cy
Top Drainage Soil Layer Thickness :	30 in
Top Drainage Soil Layer Area :	77.9 acres
Top Drainage Soil Layer Volume :	326,667 cy
Side Slope Drainage Soil Layer Thickness :	18 in
Side Slope Drainage Soil Layer Area :	40.5 acres
Side Slope Drainage Soil Layer Volume :	104,507 cy

Total Soil Required for Cap System :	1,091,497 cy
Total Soil Required for Base Liner System:	305,533 cy

Remaining Soil for Cap System Option 1

Soil Remaining after Completion of Structural Fill :	185,000 cy
---	------------

Assumes soils located onsite are appropriate for all soil components of the base liner and cap system.

HDR Computation

Project Charah Colon Mine	Computed MDP	Date 12/29/2014
Subject Permit Application	Checked JCR	Date 1/4/2015
Task Earthwork Calculations	Sheet 3	Of 3

Option 2: Cap System Soil, Geocomposite Drainage Layer, and Geomembrane

See drawings for soil permeability requirements

Topsoil Thickness : 6 in
 Topsoil Area : 118.4 acres
 Topsoil Volume : 114,575 cy

Top Unclassified Soil Thickness : 66 in
 Top Unclassified Soil Area : 77.9 acres
 Top Unclassified Soil Volume : 703,590 cy

Side Slope Unclassified Soil Thickness : 42 in
 Side Slope Unclassified Soil Area : 40.5 acres
 Side Slope Unclassified Soil Volume : 235,141 cy

Total Soil Required for Cap System :	1,053,306 cy
Total Soil Required for Base Liner System:	305,533 cy

Remaining Soil for Cap System Option 2

Soil Remaining after Completion of Structural Fill :	223,000 cy
---	------------

Assumes soils located onsite are appropriate for all soil components of the base liner and cap system.

This page intentionally left blank.

Colon Cut/Fill Report

Generated: 2015-01-04 14:07:57
By user: jgaul
Drawing: C:\pwworking\tpa\d0602582\C:\pwworking\tpa\d0602582\00C-GP01200.dwg

Volume Summary ¹							
Name	Type	Cut Factor	Fill Factor	2d Area (Sq. Ft.)	Cut (Cu. Yd.)	Fill ² (Cu. Yd.)	Net (Cu. Yd.)
Earthwork 1-4-15	full	1.000	1.000	6013250.00	1835158.71	252721.92	1582436.79<Cut>

1. Volumes are based on comparison of the existing ground surface to the design basegrades.
2. No bathymetric survey was performed; therefore, fill quantities do not account for soil volumes needed to backfill pond areas.

Cut/Fill Report

Generated: 2015-01-04 11:32:03
By user: jgaul
Drawing: C:\pwworking\tpa\d0602582\C:\pwworking\tpa\d0602582\00C-GP03200.dwg

Volume Summary ³							
Name	Type	Cut Factor	Fill Factor	2d Area (Sq. Ft.)	Cut (Cu.)	Fill (Cu. Yd.)	Net (Cu. Yd.)
Colon Airspace 1-4-15	full	1.000	1.000	5244150.00	637.82	7250433.65	7249795.83<Fill>

3. Airspace calculated from top of liner.

Colon Cut/Fill Report

Generated: 2015-01-04 17:16:23
By user: jgaul
Drawing: C:\pwworking\tpa\d0602582\C:\pwworking\tpa\d0602582\00C-GP03200.dwg

Volume Summary							
Name	Type	Cut Factor	Fill Factor	2d Area (Sq. Ft.)	Cut (Cu.)	Fill (Cu. Yd.)	Net (Cu. Yd.)
Phase 2	bounded	1.000	1.000	2229650.68	0.00	3363764.67	3363764.67<Fill>
Phase 1	bounded	1.000	1.000	1632689.59	146.27	2249969.16	2249822.89<Fill>
Phase 3	bounded	1.000	1.000	1280763.23	2.11	1635916.86	1635914.74<Fill>

Totals							
				2d Area (Sq. Ft.)	Cut (Cu.)	Fill (Cu. Yd.)	Net (Cu. Yd.)
Total				5143103.49	148.39	7249650.69	7249502.31<Fill>

* Value adjusted by cut or fill factor other than 1.0

The quantities here assume vertical boundaries between phases.

Charah Colon Mine Reclamation Timeline

Estimated Daily Ash Placement = 6,000 tons per day
 Operational days = 260 days per year
 Estimated Annual Ash Placement = 1,560,000 tons per year or 1,248,000 cys per year
 Estimated Ash Density = 1.25 tons per cy
 Estimated Start of Filling = Aug-15

	Footprint (Ac)	Ash Volume (cy)*	Estimated Time for Ash Placement (yr)	Estimated Start of Closure Date	Estimated Closure Completion Date**
Phase 1	38.1	2,250,000	1.80	May-17	Nov-18
Phase 2	51.2	3,363,800	2.70	Jan-20	Jul-21
Phase 3	29.4	1,636,000	1.31	May-21	Nov-22

*Ash volume assumes vertical boundaries between phases



**Assumes 18 months to close from date of last ash placement

This page intentionally left blank.

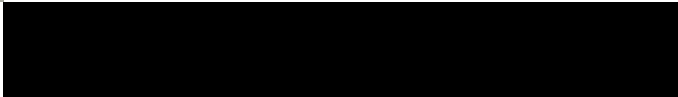

G

Financial Assurance



Financial Assurance Estimate
Certificate of Insurance



This page intentionally left blank



March 13, 2015

Mr. Norman Divers
Senior Engineer
12601 Plantside Drive
Louisville, KY 40299

RE: Colon Mine Site Structural Fill
Financial Assurance Estimate
HDR Project No. 235691

Dear Mr. Divers,

North Carolina General Statute (NCGS) §130A-309.217 (a) requires that a financial assurance be established to ensure sufficient funds are available for a structural fill for facility closure, post-closure care, corrective action, and to satisfy any potential liability for sudden and non-sudden accidental occurrences. The purpose of this letter is to provide an estimate of the expenses to meet the financial assurance requirements in NCGS §130A-309.217.

Closure

The cost for closure is provided per acre in the Closure and Post-Closure Plan in the permit application for the Colon Mine Site Structural Fill. There are two different types of final cover caps that can be built over the Colon Mine Site Structural Fill. In addition, the final cover cap thickness varies based on the location of the cap; whether on top of the structural fill or on the side slope of the structural fill. The highest final cover cap estimate in the Closure and Post-Closure Plan is \$171,300 per acre (for a cap with a geocomposite on the top of the structural fill). The largest cell area requiring closure is 31.9 acres. Therefore approximately \$5,464,470 needs to be set aside in order to cover the closure costs for the largest area requiring closure at any time at the Colon Mine Site Structural Fill.

Post-Closure Care

The cost for post-closure care is provided in the Closure and Post-Closure Plan in the permit application for the Colon Mine Site Structural Fill. The Closure and Post-Closure Plan estimates a post-closure care cost of \$2,916,000.

Corrective Action

The Corrective Action costs assume a one time release, which includes assessment monitoring, an assessment of corrective measure report/selection of a remedy, and implementation of corrective action. It is assumed that corrective action occurs in post-closure and that monitored natural attenuation would be the selected remedy. The total cost for corrective action is estimated to be approximately \$1,383,400. The North Carolina Department of Environment and Natural Resources Division of Waste Management requires that at least \$2 million be set aside for corrective action for

solid waste management facilities. Because the state is requiring a permit be obtained from the Division of Waste Management, HDR has assumed that the \$2 million corrective action threshold also applies to structural fills.

Total

The total amount to be set aside for financial assurance is \$10,380,470, as detailed in the calculation below.

Closure Costs	\$5,464,470
Post-Closure Costs	\$2,916,000
Corrective Action Costs	\$2,000,000
<hr/>	
Total Costs	\$10,380,470

If you have any questions about this cost estimate, please feel free to contact me at (704) 338-6700.

Sincerely,
HDR Engineering, Inc. of the Carolinas



Michael D. Plummer, PE
Project Manager

Enclosures



Closure Cost Estimate – Soil/Geomembrane Cap

The following is an estimate of closure costs; actual costs may vary.

Item	Description	Unit Price	Unit	Soil/Geomembrane Cap		
				Thickness (in)	Quantity	Total
					Top	Side Slope
1	Mobilization, Administration & Bonds	4%	of Items 2-9		4%	4%
2	Surveying & Control	\$ 1,600	Acres		1	1
3	Topsoil Layer	\$ 11.60	CY	6	900	900
4	Low Permeable Soil Layer*	\$ 6.70	CY	12	1,700	1,700
5	Unclassified Soil Layer*	\$ 6.70	CY	24	3,300	1,700
6	Drainage Soil Layer*	\$ 6.70	CY	30	4,100	2,500
7	Geocomposite Drainage Layer	\$ 0.70	SF		0	0
8	Geomembrane (40 mil double sided textured polyethylene)	\$ 0.60	SF		43,560	43,560
9	Seeding/Fertilizing/Mulching	\$ 1,500	Acre		1	1
10	Contingency	10%	of Items 1-9		10%	10%
11	Engineering - Plans & Specs	6%	of Items 1-9		6%	6%
12	CQA & Certification	6%	of Items 1-9		6%	6%
13	Construction Management	5%	of Items 1-9		5%	5%
				Cost Per Acre	Cost Per Acre	Cost Per Acre
				\$ 132,900	\$ 5,200	\$ 104,500

*The permeabilities for the soil layers may be different; however, the costs have been assumed to be the same with the exception of the topsoil.



Closure Cost Estimate – Soil/Geocomposite Drainage Layer/Geomembrane Cap

The following is an estimate of closure costs; actual costs may vary.

Item	Description	Unit Price	Unit	Soil/Geocomposite Drainage Layer/Geomembrane Cap			Side Slope		
				Thickness (in)	Quantity	Total	Thickness (in)	Quantity	Total
1	Mobilization, Administration & Bonds	4%	of Items 2-9		4%	\$ 5,200		4%	\$ 4,300
2	Surveying & Control	\$ 1,600	Acres		1	\$ 1,600		1	\$ 1,600
3	Topsoil Layer	\$ 11.60	CY	6	900	\$ 10,400	6	900	\$ 10,400
4	Low Permeable Soil Layer*	\$ 6.70	CY	66	8,900	\$ 59,600	42	5,700	\$ 38,200
5	Unclassified Soil Layer*	\$ 6.70	CY		0	\$ -		0	\$ -
6	Drainage Soil Layer*	\$ 6.70	CY		0	\$ -		0	\$ -
7	Geocomposite Drainage Layer	\$ 0.70	SF		43,560	\$ 30,500		43,560	\$ 30,500
8	Geomembrane (40 mil double sided textured polyethylene)	\$ 0.60	SF		43,560	\$ 26,100		43,560	\$ 26,100
9	Seeding/Fertilizing/Mulching	\$ 1,500	Acre		1	\$ 1,500		1	\$ 1,500
10	Contingency	10%	of Items 1-9		10%	\$ 13,500		10%	\$ 11,300
11	Engineering - Plans & Specs	6%	of Items 1-9		6%	\$ 8,100		6%	\$ 6,800
12	CQA & Certification	6%	of Items 1-9		6%	\$ 8,100		6%	\$ 6,800
13	Construction Management	5%	of Items 1-9		5%	\$ 6,700		5%	\$ 5,600
					Cost Per Acre	\$ 171,300		Cost Per Acre	\$ 143,100

*The permeabilities for the soil layers may be different; however, the costs have been assumed to be the same with the exception of the topsoil.



Annual Post-Closure Care Cost Estimate

The following is an estimate of post-closure costs; actual costs may vary.

1	Quarterly Site Inspections		4	Events	\$5,000	\$20,000
2	Cap System Maintenance					
	a. Seeding/Fertilizing/Mulching		1	acres	\$1,500	\$1,500
	b. Topsoil Replacement		400	CY	\$11.60	\$4,600
	c. Protective Cover Replacement		400	CY	\$6.70	\$2,700
3	Stormwater Management		1	LS	\$2,000	\$2,000
4	Stormwater Monitoring		2	Events	\$1,200	\$2,400
5	Utilities		12	Events	\$500	\$6,000
6	Mowing		2	Events	\$2,850	\$5,700
7	Fence Repairs and Security		1	LS	\$500	\$500
8	Administration		1	Events	\$2,000	\$2,000
9	Leachate System Maintenance		1	Events	\$2,500	\$2,500
10	Leachate Collection and Treatment		1,085,600	gallons	\$0.0235	\$25,500
11	Water Quality Monitoring & Report		2	Events	\$6,000	\$12,000
12	Groundwater Monitoring System Maintenance		1	Events	\$1,000	\$1,000
13	Contingency		10%		\$88,400	\$8,800
	Annual Total					\$97,200
	30-YR Total					\$2,916,000

This page intentionally left blank.



CERTIFICATE OF LIABILITY INSURANCE

CHARA-1

OP ID: JB

DATE (MM/DD/YYYY)
01/02/2015

THIS CERTIFICATE IS ISSUED AS A MATTER OF INFORMATION ONLY AND CONFERS NO RIGHTS UPON THE CERTIFICATE HOLDER. THIS CERTIFICATE DOES NOT AFFIRMATIVELY OR NEGATIVELY AMEND, EXTEND OR ALTER THE COVERAGE AFFORDED BY THE POLICIES BELOW. THIS CERTIFICATE OF INSURANCE DOES NOT CONSTITUTE A CONTRACT BETWEEN THE ISSUING INSURER(S), AUTHORIZED REPRESENTATIVE OR PRODUCER, AND THE CERTIFICATE HOLDER.

IMPORTANT: If the certificate holder is an ADDITIONAL INSURED, the policy(ies) must be endorsed. If SUBROGATION IS WAIVED, subject to the terms and conditions of the policy, certain policies may require an endorsement. A statement on this certificate does not confer rights to the certificate holder in lieu of such endorsement(s).

PRODUCER Rudd Insurance, Inc. P O Box 609 411 N Main St Madisonville, KY 42431 Bob Werner	CONTACT NAME: Bob Werner PHONE (A/C, No, Ext): 270-821-3366 E-MAIL ADDRESS: bobw@ruddinsurance.com		FAX (A/C, No): 270-825-8307
	INSURER(S) AFFORDING COVERAGE INSURER A : Indian Harbor Insurance Co		NAIC #
INSURED Green Meadow, LLC Charah, Inc. 12601 Plantside Drive Louisville, KY 40299	INSURER B :		
	INSURER C :		
	INSURER D :		
	INSURER E :		
	INSURER F :		

COVERAGES**CERTIFICATE NUMBER:****REVISION NUMBER:**

THIS IS TO CERTIFY THAT THE POLICIES OF INSURANCE LISTED BELOW HAVE BEEN ISSUED TO THE INSURED NAMED ABOVE FOR THE POLICY PERIOD INDICATED. NOTWITHSTANDING ANY REQUIREMENT, TERM OR CONDITION OF ANY CONTRACT OR OTHER DOCUMENT WITH RESPECT TO WHICH THIS CERTIFICATE MAY BE ISSUED OR MAY PERTAIN, THE INSURANCE AFFORDED BY THE POLICIES DESCRIBED HEREIN IS SUBJECT TO ALL THE TERMS, EXCLUSIONS AND CONDITIONS OF SUCH POLICIES. LIMITS SHOWN MAY HAVE BEEN REDUCED BY PAID CLAIMS.

INSR LTR	TYPE OF INSURANCE	ADDL INSD	SUBR WVD	POLICY NUMBER	POLICY EFF (MM/DD/YYYY)	POLICY EXP (MM/DD/YYYY)	LIMITS
	COMMERCIAL GENERAL LIABILITY <input type="checkbox"/> CLAIMS-MADE <input type="checkbox"/> OCCUR GEN'L AGGREGATE LIMIT APPLIES PER: <input type="checkbox"/> POLICY <input type="checkbox"/> PRO-JECT <input type="checkbox"/> LOC OTHER:						EACH OCCURRENCE \$ DAMAGE TO RENTED PREMISES (Ea occurrence) \$ MED EXP (Any one person) \$ PERSONAL & ADV INJURY \$ GENERAL AGGREGATE \$ PRODUCTS - COMP/OP AGG \$ \$
	AUTOMOBILE LIABILITY <input type="checkbox"/> ANY AUTO <input type="checkbox"/> ALL OWNED AUTOS <input type="checkbox"/> SCHEDULED AUTOS <input type="checkbox"/> HIRED AUTOS <input type="checkbox"/> NON-OWNED AUTOS						COMBINED SINGLE LIMIT (Ea accident) \$ BODILY INJURY (Per person) \$ BODILY INJURY (Per accident) \$ PROPERTY DAMAGE (Per accident) \$ \$
	UMBRELLA LIAB <input type="checkbox"/> OCCUR EXCESS LIAB <input type="checkbox"/> CLAIMS-MADE DED RETENTION \$						EACH OCCURRENCE \$ AGGREGATE \$ \$
	WORKERS COMPENSATION AND EMPLOYERS' LIABILITY ANY PROPRIETOR/PARTNER/EXECUTIVE OFFICER/MEMBER EXCLUDED? (Mandatory in NH) If yes, describe under DESCRIPTION OF OPERATIONS below	Y/N	N/A				PER STATUTE OTH-ER E.L. EACH ACCIDENT \$ E.L. DISEASE - EA EMPLOYEE \$ E.L. DISEASE - POLICY LIMIT \$
A	Pollution Legal			PEC0044848	11/12/2014	11/12/2017	Condition 4,000,000 Aggregate 8,000,000

DESCRIPTION OF OPERATIONS / LOCATIONS / VEHICLES (ACORD 101, Additional Remarks Schedule, may be attached if more space is required)

Each Pollution Condition- \$4,000,000
Aggregate - \$8,000,000
A pollution condition includes both sudden and non-sudden events

CERTIFICATE HOLDER**CANCELLATION**

NORTH-5 N.C. Dept of Environment & Natural Resources 1601 Mail Service Center Raleigh, NC 27699-1601	SHOULD ANY OF THE ABOVE DESCRIBED POLICIES BE CANCELLED BEFORE THE EXPIRATION DATE THEREOF, NOTICE WILL BE DELIVERED IN ACCORDANCE WITH THE POLICY PROVISIONS.
	AUTHORIZED REPRESENTATIVE 

© 1988-2014 ACORD CORPORATION. All rights reserved.

This page intentionally left blank.