

ZEV Related Comments



STATE OF NORTH CAROLINA
DEPARTMENT OF ENVIRONMENTAL QUALITY
217 WEST JONES STREET
RALEIGH, NC 27699

REQUEST FOR INFORMATION (RFI)
VOLKSWAGEN CONSENT DECREE ENVIRONMENTAL MITIGATION TRUST PROJECT IDEAS
December 2017

RFI Response from Brightfield Transportation Solutions

I. Brightfield Transportation Solutions: Company Introduction

Since 2010, Brightfield® Transportation Solutions (BTS) has delivered business-to-business Solar Driven® charging solutions for the rapidly expanding electric (EV) vehicle marketplace. We are a North Carolina born-and-raised company that is committed to serving our home state and its citizens.

As a technology integration company, we design, manufacture and operate our patented Solar Driven Brightfield Charging Stations. On this highly-scalable platform, we integrate best-in-class EV charging, solar production, energy storage and management, customer engagement, and data aggregation capabilities.

BTS is a team of technology and sustainability entrepreneurs with a deep understanding and passion for the electrification of transportation and its broad impacts. With over 100 years of combined experience, our leadership team's technological and consultative expertise ensures that EV strategy and infrastructure investments are market-appropriate, economically viable and future-proof.

BTS provides customized EV infrastructure solutions to our forward-acting clients in the retail, destination, municipality, university, workplace and utility markets. Our innovative solutions are designed to enhance brands, increase customer and employee loyalty, manage energy resources, and promote future-oriented sustainability solutions; all while keeping our clients' business goals and realities at the forefront.

EV Infrastructure Leadership in North Carolina:

- D.O.E. Clean Cities Stakeholder and Founding Clean Vehicle Coalition Steering Committee Member
- Founding Plug-In NC Steering Committee Member
- NC Sustainable Energy Association Member
- NC Sustainable Fleet Conference Sponsor



- Blue Ridge EV Club Sponsor
- NC Mainstreet Conference Sponsor
- Presenter before the NC Joint Legislative Commission on Energy Policy
- Speaker at many state conferences including NC State Energy Conference, Making Energy Work, UNC Clean Tech Summit, Appalachian Energy Summit and Sustainable Fleets Conference

Received over \$1.5M in grant and industry funding to support jobs in NC and deployment of Level 2, DC Fast Charger, and solar-integrated public charging infrastructure across the State:

- US Department of Energy
- NC Department of Commerce
- NC Green Business Fund
- Advanced Energy
- NC Clean Energy and Technology Center
- NC Department of Transportation
- Nissan North America
- BMW
- EVgo

Provided product, consulting and/or strategic advising to a multitude of NC entities:

- NC Municipalities
 - Charlotte (current EV Infrastructure Consultants)
 - Raleigh
 - Asheville
 - Greensboro
 - Buncombe County
 - Orange County
 - Forsyth County
 - Jackson County
 - Durham
 - Hendersonville
 - Flat Rock
 - Lake Lure
 - Dallas
 - Wadesboro
 - Salisbury
 - Mars Hill
 - Marshall
 - Maggie Valley
 - Brevard
 - Warrenton
 - Lenior
 - Hickory
 - Warrenton
- Duke Energy
- NC Electric Cooperatives
- Crescent Communities, LLC
- Ingles Supermarkets
- Earth Fare Grocery
- Hot Springs Resort and Spa
- NC Division of Air Quality
- NC State Parks, Western Region
- NC State Forest Service
- Centralina Council of Governments
- Land of Sky Council of Governments
- Triangle J Council of Governments
- Piedmont Triad Council of Governments
- NC Arboretum
- UNC Asheville

- Western Carolina University
- Appalachian State University

II. Company Contact Information & Mitigation Project Category

Company Name:	Brightfield Transportation Solutions
Contact Person:	Stan Cross Chief Executive Officer
Entity Type:	Non-Government
Mailing Address:	P.O. Box 5502 Asheville, NC 28813
Phone Number:	(828) 335-1539
Email Address:	scross@brightfieldts.com
Mitigation Project Category:	Category 9: Light Duty (LD) zero emission vehicle (ZEV) Supply Equipment (Level 1, Level 2, or fast charging equipment) and hydrogen fuel dispensing equipment.

III. Response to Section 2 – VW Program and Solicitation Design Questions

Brightfield has the following answers to the specific questions numbered 1-14.

- **Question 1**—Prioritization should include the following:
 - Geographical locations for DC Fast Chargers that connect all NC cities and towns along major state and federal highways from the mountains to the sea to support state-wide EV ownership.
 - Geographical locations for Level 2 Chargers where amenities exist that will attract and service EV drivers while they wait to charge such as commercial downtowns and retail centers.
 - Public charger locations that offer 24/7 access and high visibility to all consumers because consumer confidence in ample public EV charger availability is a primary driver of EV adoption.
 - Sites where hosts are willing to designate parking as ‘EV Only’ at a minimum ratio of 1 parking space per charging cord installed.
 - Workplace charger locations where proven demand for chargers exists today or where it is demonstrated that installation of chargers will create demand.
 - Charger equipment that runs on open standards protocols (OCPP) to create an open application protocol which allows EV charging stations and central management systems from different vendors to communicate with each other.

- Open-standards based networked charging stations that will enable the collection of valuable usage data and will allow site hosts to charge drivers for use to offset long-term operation and maintenance costs.
- Projects that integrate renewable energy solutions to provide the greatest air quality and transportation energy security benefits to NC citizens.
- Projects that integrate energy storage solutions when needed to mitigate demand charge and/or peak load grid-related issues, and provide emergency back-up power.
- NC-based hardware and installation companies that generate jobs in NC.
- **Question 2**—EV charging infrastructure is lagging EV sales growth both in NC and nationally. Today there is approximately 1 public charger for every 15 EVs on the road. According to industry studies by NREL, Rocky Mountain Institute and others, to meet demand, that ratio needs to be 1 public charger for every 5 EVs. Hence, there exists high demand for public chargers. Based on the performance of the 28 DC Fast Charge and Level 2 public charging stations Brightfield owns and operates across NC, immediate demand will likely to be upwards of 3 uses per day per public charging station with a likely 50% annual growth rate.
- **Question 3**—The full allowable 15% of trust funds should be allocated to EV charging infrastructure. NC is becoming a top-tier EV market with Raleigh and Charlotte among the top 25 fastest growing municipal markets in 2017. Strong statewide EV adoption will significantly improve air quality, reduce greenhouse gas emissions, improve NC's transportation energy security and put money on North Carolinians' pockets from the on-average \$1,300 in annual gas and maintenance savings EVs provide. Access to ample public and workplace charging drives market growth.
- **Question 6**—Municipalities play an important role in providing quality sites for EV chargers. Reserving funds to support EV charger deployment in downtown commercial districts, especially Level 2 stations, is wise as these investments have the added benefit of bringing economic development to NC's main streets. Additionally, reserving funds for deployment of chargers at NC State Parks, the NC Arboretum and other such destinations would be wise as well as these state-assets attract EV driving residents and tourists alike and provide high visibility sites.
- **Question 7**—To maximize broad economic development benefits and provide access to all, funds should be distributed across the state focusing on primary transportation corridors, high visibility and high need locations, tourism destinations and regions underserved by EV infrastructure.
- **Question 8**—Instead of matching funds in the form of cash, we recommend requiring an in-kind match of that could include, for example, waiving permitting fees, supporting installation work, the value of 'EV Only' designated parking, and providing public outreach.
- **Question 9**—Size limits do not make sense as each location will have its own unique prescription based on intra or inter-city location, proximity to high growth regions, site constraints including access to utilities, and site host willingness to reserve parking as 'EV Only'.
- **Question 10**—Refer to Question 1 response.
- **Question 11**—Keep it simple and avoid a one-size-fits-all approach. Maintaining the flexibility for strategic deployment of diverse charger technology applications is critical for success. What a large municipality vs small town or a large corporation vs small business can support

varies widely as does the technology application and costs of an intra-city DC Fast Charge depot vs a destination Level 2 station vs an installation designed to maximize consumer visibility.

- **Question 12**—A tool such as Brightfield’s Solar Driven Calculator that measures the triple-bottom line environmental, social and economic benefits of EV charger deployment, charger usage, and EV adoption will help decision makers understand the value of trust funds invested in EV infrastructure and will inform strategy and provide justification for future investment.
- **Question 13**—Along with keeping it simple and avoiding a one-size-fits-all approach, creating a transparent and easy application process that includes clear descriptions of project goals, provides specific yet flexible site host requirements, supports large or small installations based on the ideal prescription at a given location, offers charger and network technology choice across OCPP compliant platforms, provides a list of pre-qualified consultants, charger providers and installers, and communicates the value proposition for hosting EV chargers.
- **Question 14**—See response to Question 13. It may be wise to engage the NC Council of Governments to lead outreach to stakeholders. They have been working in the EV infrastructure space for years, have built stakeholder trust, and have experience coordinating large state-wide grant funded projects.

IV. Recommendations and Attributes for Volkswagen Mitigation Trust Projects

BTS sees the electrification of our transportation systems as a richly complex set of problems and opportunities with many moving parts and multiple potential “correct” paths forward. What is clear, is that the electrification of transportation is a transformation that will impact multiple aspects of our state and our economy; and that governmental agencies have a role to play, ensuring we are looking forward toward robust, flexible and appropriate solutions.

Further, we see it as appropriate that the NC DEQ see the administration of these funds as an opportunity to envision “pilot” programs that accelerate adoption and serve as an example of fully-integrated EV charging solutions. This is not to say that governmental entities will be in the long-term position of installing EV infrastructure, but that the NC DEQ has a current and important role to play in both the administration of these funds and in the evolution of this nascent, yet important industry.

As the state envisions its allocation and management of these funds and the future of electric vehicle charging infrastructure, BTS has several recommendations and suggestions for project attributes that are listed immediately below:

- NC-based companies be given strong consideration; thus building local and regional capacities, creating state-based jobs and the funds/revenues remain in-state and multiply in the cycle of economic development.
- Environmental and air quality issues and opportunities remain front-and-center in the disbursement of these funds. This is the named purpose of the funds.

- EV Infrastructure installations be visible to the general public, thus serving to drive awareness and EV adoption.
- Projects strictly adhere to open standards for EV chargers, ancillary equipment, payment platforms, data strategies, and network management.
- Projects integrate of solar energy generation and the ability for these assets for contribute to environmental quality and optimal grid performance.
- Consideration of the integration of energy storage and the ability for these assets for contribute to environmental quality and optimal grid performance.
- Consideration of the integration of software to enable optimal management of charging assets and related charging activity.
- Adherence to open data standards and appropriate public access to data is vital.
- Consideration of the integration of robust payment platforms, and thoughtful programs designed to test various scenarios and cost/rate experimentations.
- Development of contractual relationships to ensure proper management, maintenance and support for of all aspects of these projects.

A visual depiction of EV charging infrastructure (including L2, DCFC, solar generation, and energy storage) we envision for North Carolina can be seen below:



This collection of capabilities and the bulleted list of project attributes above will provide a broad look forward at the impacts and opportunities that the electrification of transportation presents. This broad look forward will inform the future, as technology and the needs of the

charging public evolve, and help determine what future success looks like. With that perspective, North Carolina's DEQ will enable and participate in modeling best-in-class technologies, services, and the public/private engagement mechanisms that provide scalable, fully integrated EV charging infrastructure solutions for its citizenry.

V. Two Examples of Proposed EV Infrastructure Projects

1. T2 Brightfield Fast Charging Depot Pilot Project



BTS envisions 10 highly visible grid-tied Fast Charging Depot installations across NC that will connect the Mountains to the Sea (both Wilmington and the Outer Banks) to enable in-state EV drivers and visitors alike to navigate the major transportation corridors that link NC's primary destinations. Examples of possible locations for these 10 Brightfield Fast

Charging Depots include Asheville, Hickory, Charlotte, Winston-Salem, Greensboro, Raleigh, Fayetteville, Lumberton, Rocky Mount, and Plymouth.

The DC Fast Chargers provide approximate 30 min charge time to get drivers back on the highway toward their destination. Level 2 charges are included to provide local drivers charging options and to offer back-up in case DC Fast Chargers are occupied. The grid-tied Brightfield Solar Canopy provides 24/7 charging plus on-site renewable energy to offset charger electricity use, high visibility and consumer inspiration, and protection for equipment and drivers from the elements (see Appendix for Spec Sheet).

These Brightfield Fast Charging Depots will draw EV drivers off the road and onto site hosts' properties creating economic value as drivers purchase goods and services while waiting for their EV to charge. The high visibility of the innovative T2 Brightfield structure will broadcast the arrival of electric transportation to all passers-by thereby increasing broad consumer awareness to stimulate EV market activity. Depot installations will be future-proofed by being pre-wired for cost effective expansion or upgrade of charging equipment as the market demands, this includes impending increases in DC Fast Charger output.



This cross-state fast charging pilot project is modeled after what the auto industry (VW, Nissan, GM, Tesla and others) has determined are necessary EV infrastructure investments to drive EV mass market penetration: when drivers believe that the charging infrastructure is in place to get where they *want* and *need* to go, and longer range EVs are available at competitive prices, EV sales will increase. This pilot project will provide extremely useful data that will show how EVs are moving across NC, inform where future stations are needed, and demonstrate the economic development potential of EV infrastructure investment.

Battery storage and energy management technologies can be added to any Brightfield Charging Station where grid enhancement or back-up power supply needs exist. The costs of that additional value-add are not reflected below.

T2 Brightfield Fast Charging Depot Project Estimate per Station *

- Solar-Integrated T2 Brightfield Charging Station = \$40K**
- EV Charging Stations (two 50KW DCFC stations + four Networked Level 2 cords) = \$60K**
- Project Installation = \$40K**
- TOTAL per Station = \$140K**
- PROJECT TOTAL (10 stations across NC) = \$1.4M**

**Note: Pricing is an estimate. Actual hardware pricing will vary based on specific DCFC and Level 2 charging station brands selected. Installation pricing will vary based on specific site issues or lack thereof. Pricing does not include tax or shipping.*

Estimated Project Benefits*	Year One 2018	Year Five 2022
Station Performance		
Charge Events /Location /Day	12	45
Total Annual Charge Events	58,400	164,250
Cumulative EV Miles Delivered by Chargers	1,752,000	30,660,000
Tailpipe Emissions Reduced by EVs		
Cumulative Greenhouse Gas Emissions Reduced (lbs.)	1,502,677	26,296,846
Utility Emissions Reduced by Solar Canopies		
Cumulative CO2 Reduced (lbs.)	477,026	8,347,952
Cumulative NOX Reduced (lbs.)	346	6,063
Cumulative SOX Reduced (lbs.)	552	9,658

**Benefits calculated using Brightfield Transportation Solutions proprietary Solar Driven Calculator*

2. T1 Brightfield Destination Charging Project Pilot



BTS envisions 20 highly visible grid-tied Level 2 Destination charging stations placed at strategic destinations across NC that will provide needed charging for both local drivers and those traveling. Examples of destinations include NC State Parks, National Parks, downtown municipal commercial districts, and attractions.

The networked Level-2 chargers enable drivers to top off their batteries while at their destination. The grid-tied Brightfield Solar Canopy provides 24/7 charging plus on-site renewable energy to offset charger electricity use, high visibility and consumer inspiration, and protection for equipment and drivers from the elements (see Appendix for Spec Sheet).

Based on the data BTS has gathered from the Level 2 charging stations we've deployed, drivers spend 1.5 hours on average at a Level-2 station. Hence, drivers become captive consumers for a significant period of time, which translates to potential economic value for site hosts as drivers purchase goods and services while waiting for their EV to charge. The high visibility of the innovative T1 Brightfield structure will broadcast the arrival of electric transportation to all passers-by thereby increasing broad consumer awareness to stimulate EV market activity.

This cross-state destination charging pilot project is modeled after what the auto industry (VW, Nissan, GM, Tesla and others) has determined are necessary EV infrastructure investments to drive EV mass market penetration: when drivers believe that the charging infrastructure is in place to get where they *want* and *need* to go, and longer range EVs are available at competitive prices, EV sales will increase. This pilot project will provide extremely useful data that will show what destinations EV drivers are going to across NC, inform where future stations are needed, and demonstrate the economic development potential of EV infrastructure investment.

T1 Brightfield Destination Charging Project Estimate per Station *

Solar-Integrated T2 Brightfield Charging Station = \$15K

EV Charging Stations (four Networked Level 2 cords) = \$10K

Project Installation = \$10K

TOTAL per Station = \$35K

PROJECT TOTAL (20 stations across NC) = \$700K

**Note: Pricing is an estimate. Actual hardware pricing will vary based on specific Level 2 charging station brands selected. Installation pricing will vary based on specific site issues or lack thereof. Pricing does not include tax or shipping.*

Estimated Project Benefits*	Year One	Year Five
	2018	2022
Station Performance		
Charge Events /Location /Day	8	20
Total Annual Charge Events	58,400	146,000
Cumulative EV Miles Delivered by Chargers	1,868,800	22,192,000
Tailpipe Emissions Reduced by EVs		
Cumulative Greenhouse Gas Emissions Reduced (lbs.)	1,602,855	19,033,908
Utility Emissions Reduced by Solar Canopies		
Cumulative CO2 Reduced (lbs.)	508,828	6,042,327
Cumulative NOX Reduced (lbs.)	370	4,388
Cumulative SOX Reduced (lbs.)	589	6,990

**Benefits calculated using Brightfield Transportation Solutions proprietary Solar Driven Calculator.*

VI. Conclusion

Thank you for the opportunity to provide these comments. Brightfield Transportation Solutions looks forward to participating in the ongoing process, as the statewide strategy for electrifying mobility in the great state of North Carolina continues to move forward.

A North Carolina company, BTS has deep EV market expertise and since 2010 has been committed and focused on building the future of EV charging. We would welcome any inquiry for further information or comment and invite interested and related parties to contact us using the information provided above.

Appendix: Brightfield Charging Station Spec Sheets

T1 BRIGHTFIELD CHARGING STATION

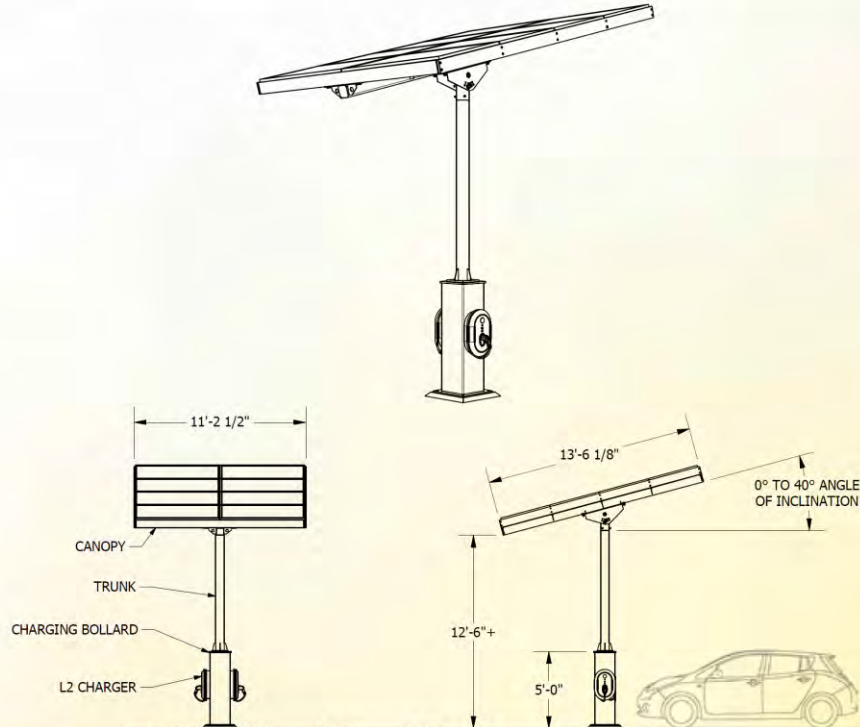

TECHNICAL INFORMATION

- Confirm site's solar orientation and overhead shading to ensure viability.
- Note that distance from charging station to utility interconnection can impact cost due to need for longer trench or bore run and more conduit and wire.
- Typical Level 2 charger needs a dedicated 40A breaker and typical DC Fast Charger needs a dedicated 100A@480V and 200A@208V breaker.
- Utility upgrades maybe required.
- Brightfield footings require 3000+ PSI concrete with fiber reinforcement and contain an engineered rebar cage (provided by BTS) to ensure structural integrity.
- BTS recommends that all operable charger components are mounted below 48" and that access to chargers is unobstructed for ADA access. Local codes may have additional ADA compatibility requirements.
- Standard Brightfield Charging Stations are engineered to meet 120MPH wind and 20PSF live load ratings (160+ MPH wind and higher live load ratings upgrades are available on all models at additional cost).
- Networked Chargers communication capabilities require secure WiFi, LAN or Cellular (cell fees will apply), Solar Inverter reporting functionality requires WiFi or LAN.
- Solar array can be optimized for existing Electrical Service Panel, or upgrades can be made. Considerations are based on utility interconnection type, and other factors that are addressed in the typical design phase.
- All Brightfield fasteners are galvanized, stainless steel, aluminum or other corrosion resistant material.
- BTS specs 'Buy American' compliant solar panels and American made steel and aluminum, unless no other option is available.

BRIGHTFIELD® SOLAR DRIVEN® BENEFITS

Brightfield® Solar Canopy Size	2.4 kW
Annual Electricity Production	3,679 kWh
Annual Solar Driven® EV Miles Produced	15,085
Annual Gallons of Gasoline Displaced	580
Annual Barrels of Oil Avoided	30
Annual Emissions Avoided	18,591 lbs.

TAX CREDITS

Solar-integrated Brightfield Charging Stations qualify for 30% federal solar tax credit and accelerated bonus depreciation that combine to offset upwards of 60% purchase price Year 1.*

Stand-alone Brightfield Charging Bollards qualify for 30% federal alternative fueling station tax credit. *

Solar-integrated Brightfield Charging Stations can be financed through our partnership with SparkFund. Brightfield / SparkFund clients are eligible for \$0 down financing with low rates and choice of terms subject to credit worthiness.

* Clients should consult their certified tax professional as to their eligibility for tax benefits and the ramifications of their participation in this activity for their unique and individuated tax circumstances.

T2-EW BRIGHTFIELD CHARGING STATION

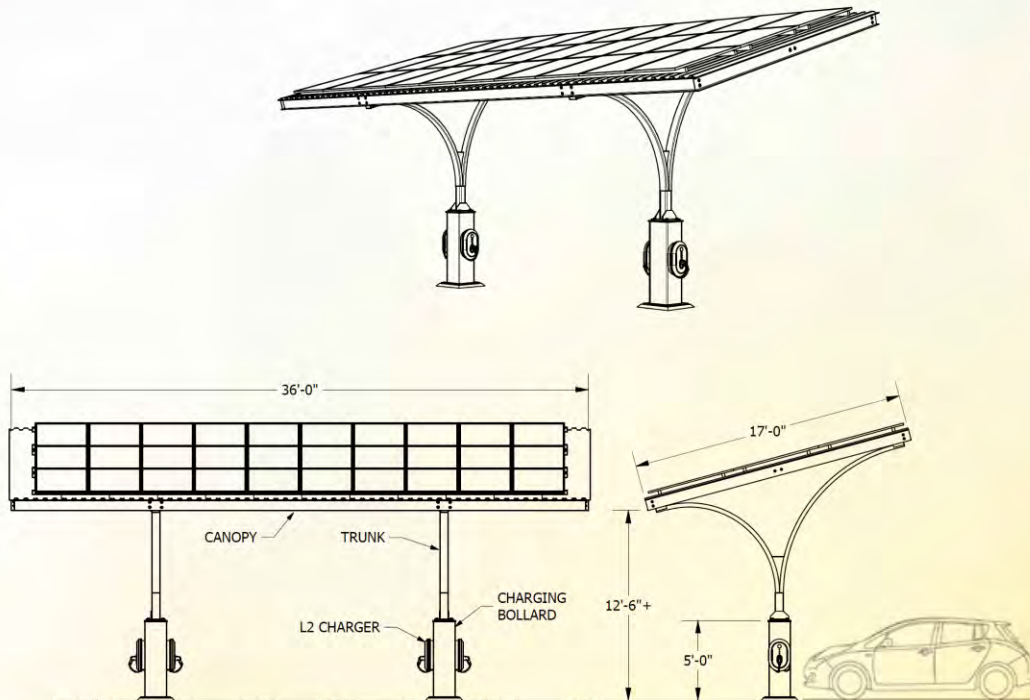

TECHNICAL INFORMATION

- Confirm site's solar orientation and overhead shading to ensure viability.
- Note that distance from charging station to utility interconnection can impact cost due to need for longer trench or bore run and more conduit and wire.
- Typical Level 2 charger needs a dedicated 40A breaker and typical DC Fast Charger needs a dedicated 100A@480V and 200A@208V breaker.
- Utility upgrades maybe required.
- Brightfield footings require 3000+ PSI concrete with fiber reinforcement and contain an engineered rebar cage (provided by BTS) to ensure structural integrity.
- BTS recommends that all operable charger components are mounted below 48" and that access to chargers is unobstructed for ADA access. Local codes may have additional ADA compatibility requirements.
- Standard Brightfield Charging Stations are engineered to meet 120MPH wind and 20PSF live load ratings (160+ MPH wind and higher live load ratings upgrades are available on all models at additional cost).
- Networked Chargers communication capabilities require secure WiFi, LAN or Cellular (cell fees will apply), Solar Inverter reporting functionality requires WiFi or LAN.
- Solar array can be optimized for existing Electrical Service Panel, or upgrades can be made. Considerations are based on utility interconnection type, and other factors that are addressed in the typical design phase.
- Brightfield Charging Stations can be installed to ensure effective storm watermanagement at the site.
- All Brightfield fasteners are galvanized, stainless steel, aluminum or other corrosion resistant material.
- BTS specs 'Buy American' compliant solar panels and American made steel and aluminum, unless no other option is available.

BRIGHTFIELD® SOLAR DRIVEN® BENEFITS

Brightfield® Solar Canopy Size	9 kW
Annual Electricity Production	13,797 kWh
Annual Solar Driven® EV Miles Produced	56,568
Annual Gallons of Gasoline Displaced	2,176
Annual Barrels of Oil Avoided	112
Annual Emissions Avoided	69,716 lbs.

TAX CREDITS

Solar-integrated Brightfield Charging Stations qualify for 30% federal solar tax credit and accelerated bonus depreciation that combine to offset upwards of 60% purchase price Year 1.*

Stand-alone Brightfield Charging Bollards qualify for 30% federal alternative fueling station tax credit. *

Solar-integrated Brightfield Charging Stations can be financed through our partnership with SparkFund. Brightfield / SparkFund clients are eligible for \$0 down financing with low rates and choice of terms subject to credit worthiness.

* Clients should consult their certified tax professional as to their eligibility for tax benefits and the ramifications of their participation in this activity for their unique and individuated tax circumstances.

GENERAL MOTORS

Britta K. Gross Director
Advanced Vehicle Commercialization Policy
Environment, Energy & Safety Policy

General Motors Global Headquarters
MC: 482-C30-C76
300 Renaissance Center
Detroit, MI 48265-3000

19 December, 2017

NC VW Settlement RFI

Department of Environmental Quality (DEQ), Division of Air Quality – Mobile Sources

217 West Jones Street

1641 Mail Service Center

Raleigh, NC 27699-1641

Subject: GM Comments relative to the North Carolina VW Settlement RFI

General Motors LLC (GM) appreciates the opportunity to provide input on the use of funding in the state's Environmental/Beneficiary Mitigation Plan and would like to encourage North Carolina to use the maximum allowed 15% of the fund (equating to approximately \$14mil) to increase the availability of critically-needed electric vehicle (EV) charging stations. There are currently about 7,500 EVs registered in North Carolina, and in order to grow the EV market and attract even more advanced transportation technologies to the state, such as self-driving EVs, North Carolina needs to invest in a charging infrastructure network that addresses consumer and industry concerns.

Automakers have made enormous investments in the electrification of transportation – GM alone has invested billions of dollars to develop electrification technologies, including the state-of-the-art Chevrolet Volt and Chevrolet Bolt EV, which has swept the industry's most prestigious car awards, including North America Car of the Year, Motor Trend's® 2017 Car of the Year, MotorWeek's 2017 Drivers' Choice "Best of the Year" Award, and Green Car Journal's Green Car of the Year. The Bolt EV is the industry's first affordable, long-range EV with an EPA estimated range of 238 miles-per-charge, and is now available at Chevrolet dealers across all 50 states, including North Carolina. In fact, after 10 months of continual sales growth, the Bolt EV is now the top-selling EV in the United States. This advanced technology will require more widespread charging infrastructure to convince consumers that EVs can be driven anywhere they need to go. Thus the urgency to rapidly expand EV charging infrastructure across North Carolina.

While the majority of all EV charging today is done at the home, there are still critical infrastructure needs not met by single-family home charging. And to maximize the impact of limited state funds, it is important to invest strategically. GM would prioritize today's key infrastructure needs as follows:

1. **Highway corridor DC fast-charging** most visibly inspires consumer confidence in the driving range, and practicality, of EVs. A 2016 survey of 2,500 consumers by Altman Vilandrie & Company found the top reason customers gave for not wanting to purchase a plug-in electric vehicle was a perceived lack of charging stations (85%). Highly visible corridor EV charging (SAE industry standard) can help address this consumer perception issue.
2. **Workplace EV charging** creates an EV “showroom” that very effectively grows EV awareness among corporations, and employees of these corporations. According to US DOE data, workplace charging results in employees 6X more likely to purchase an EV than employees at companies not offering workplace charging.
3. **Multi-unit dwelling EV charging** provides an important opportunity to expand EV adoption to consumers residing in townhomes, condominiums, and apartments, who may not have access to a “home” charger every evening. This is currently an untapped segment of potential EV buyers. This need can be met by Level 1 or Level 2 charging directly at the multi-unit dwellings, or by neighborhood DC fast-charge hubs that can serve these residents.
4. **Public EV charging at key destinations** is also important to increase the practicality of EVs and the number of places an EV can go, with a special focus on destinations typically outside a consumer’s normal daily driving patterns (e.g. airports, beaches, hotels, resorts, etc.).

EV charging infrastructure is vital to the growth of the EV market and will lead to long-lasting emissions reductions that increase over time as the market expands. And North Carolina’s low electricity prices mean that electric vehicles are an important economic driver for North Carolina. Finally, we encourage the state to directly engage all electric utilities in the strategic planning of EV infrastructure to ensure the most cost-effective and grid-responsible EV charging solutions. Utilities can also play an important role in outreach and education to support the transformational change that is required to electrify transportation.

The VW Environmental Mitigation Trust is an opportunity to invest in forward-looking infrastructure that lays a much-needed foundation for EV market growth and will help attract even more advanced transportation technologies to North Carolina. GM greatly appreciates North Carolina’s commitment to support the strategic transition to transportation electrification and all efforts to help drive this emerging market.

Sincerely,

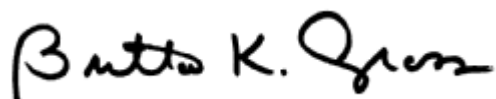

Britta K. Gross, Director
Advanced Vehicle Commercialization Policy
britta.gross@gm.com
(586) 596-0382



ChargePoint, Inc.
254 East Hacienda Avenue | Campbell, CA 95008 USA
+1.408.841.4500 or US toll-free +1.877.370.3802

NC VW Settlement RFI
Division of Air Quality – Mobile Sources
217 West Jones Street
1641 Mail Service Center
Raleigh, NC 27699

December 29, 2017

North Carolina's RFI Regarding the Use of Settlement Funds: VW Environmental Mitigation Trust ChargePoint Response

ChargePoint is pleased to provide written responses to the State of North Carolina regarding the best use of funds stemming from the VW settlement and the State's allocation from the Environmental Mitigation Trust. The Trust funds provide a significant opportunity for the State to mitigate the environmental harm VW diesel vehicles caused, as well as advance key transportation segments that produce long-term benefits to the State and its communities.

In summary, ChargePoint recommends that North Carolina prioritize investment of Environmental Mitigation Trust funds into projects utilizing electricity as a fuel and that utilize a standard connector. We strongly support the State's intention to commit the maximum 15% of its Trust allocation towards smart, light-duty electric vehicle charging infrastructure. We believe that this investment in transportation electrification significantly contributes to the NO_x mitigation goals of the Environmental Mitigation Trust, and NO_x reductions from charging sessions are easily and empirically calculable. Moreover, funding for EV infrastructure is needed to meet the demands of today's 8,500 EV drivers in North Carolina, let alone support the exponential growth of EVs in years to come. In a state that currently has just 1,000 public charging ports, this small portion of the investment could double the number of public charging stations deployed in communities across North Carolina.

ChargePoint is the largest electric vehicle (EV) charging network in the world, with charging solutions for every charging need and all the places EV drivers go: at home, work, around town, and on the road. With more than 43,000 independently-owned charging spots and more than 7,000 customers nationwide, ChargePoint drivers have completed more than 29 million charging sessions, saving upwards of 28 million gallons of gasoline and driving more than 687 million gas-free miles. In addition, there are currently more than 500 public ChargePoint charging spots in the State of North Carolina.

Background on VW Settlement

In 2016, Volkswagen entered into a consent decree with the federal government and the State of California to resolve damages, penalties, and mitigation actions associated with 2.0- and 3.0-liter vehicles. Appendix D establishes a \$2.9 billion trust for environmental mitigation, the funds of which will be allocated to all 50 states in amounts proportionate to each state's number of VW diesel vehicles involved in the case. On October 2, 2017, parties to the Settlement filed trust agreements with the Court, establishing Environmental Mitigation Trust effective date. In North Carolina's case the State will receive over \$92 million.

Within 60 days of the trust effective date (by December 1, 2017), each state designated and certified a beneficiary agency, an entity charged to oversee program implementation and funds. Governor Cooper selected the Department of Environmental Quality (DEQ) to be the lead agency and act on behalf of the trust for the State of North Carolina.

Section 1 – Project Applicant Information

- Company: ChargePoint
- Contact Person: David Schatz
- Non-Government
- Mailing Address:

254 East Hacienda Avenue
Campbell, CA 95008

- Phone Number: 215-858-4748
- Email Address: david.schatz@chargepoint.com

Section 2 – VW Program and Solicitation Design Questions

1. How should DEQ prioritize projects?

ChargePoint strongly believes that priority should be given to eligible project categories that focus on expanding transportation electrification throughout the State, including:

- a. All-Electric: Local Freight Trucks and Port Drayage Trucks
- b. All-Electric: Class 4-8 School Bus, Shuttle Bus, or Transit Bus
- c. All-Electric: Class 4-7 Local Freight Trucks
- d. All-Electric: Forklifts and Port Cargo Handling Equipment
- e. Light Duty Zero Emission Vehicle Supply Equipment

Committing priority to eligible project categories that promote electrification and utilize a standard connector will accelerate the State's adoption of transportation electrification technologies, increase access to electric-drive vehicles, and enable local energy use to achieve day-one emissions reductions in communities across North Carolina.

2. What is the anticipated demand for each eligible project type?

Demand for electrification projects across the State of North Carolina is expected to increase rapidly in the coming years, and concentrating Environmental Mitigation Trust funds on electrification will facilitate the transition to a 21st Century transportation sector.

Many communities in the State are already adopting electric bus models, and as more electric truck and forklift models become available over the 10-year investment horizon of the Trust, greater adoption is

expected in those categories as well. Greensboro Transit Authority recently moved forward with a purchase of a small fleet of electric buses, with an expected reduction of 540,000 kg of emissions and a cost savings of more than \$1.7 million over twelve years. Other municipalities in North Carolina are exploring a similar procurement, recognizing the benefits of moving public transportation to electric models. For example, electric buses get the equivalent of 21 miles per gallon (MPG), compared to 4 MPG in conventionally-fueled buses. Every mile driven in an electric bus will save taxpayers about 60-70% of what they would have paid with a diesel engine, per mile.

Tesla, Cummins, BYD, Fuso, and other truck manufacturers have made recent announcements for new models of electric trucks, indicating that the electric trucking segment is quickly adapting to meet demand. North Carolina's investment of Trust funds into medium- and heavy duty electric truck projects will stimulate greater local demand to transform entire trucking fleets.

Nationally, the market for EV charging has expanded rapidly with the exponential growth of electric vehicles, and there are over 46,000 public charging ports. There are also thousands of private, or limited-access charging stations around the country, at workplaces, retail establishments, and fleet operations. In North Carolina, ChargePoint's deployments have increased 37% year-over-year (Q3 2016 – Q4 2017). In our business model, site hosts invest in, own, and operate charging infrastructure on their properties. There are many reasons why site hosts make the decision to invest in smart charging infrastructure, but a principle reason is that infrastructure brings EV drivers onsite. For a retail establishment, attracting more drivers could mean increased revenue in a store, as EV drivers charge while shopping. For a workplace, employers offer charging as an amenity to their EV driver employees, so that they may charge while at work. In any case, the demand for EV charging services is inherently connected to join the growing population of EV drivers in North Carolina. Moreover, more EV infrastructure, both Level 2 and DC fast charging, is required to meet the demands of today's drivers and set the foundation for tomorrow's drivers. The Environmental Mitigation Trust funds can work towards satisfying both of those demands.

Committing Environmental Mitigation Trust funds to electric vehicle charging deployments will lead to the fastest and most efficient use of Environmental Mitigation Trust funds. A number of charging station providers already operate in North Carolina in a highly competitive market, and establishing a funding program can leverage the existing market's activities. While some eligible categories may require months or years of project and selection diligence, the EV charging market is already setup to fully deploy within a prequalified grant program structure in a matter of months.

3. The percentage of trust funds, if any, that DEQ should devote to Light Duty Zero Emission Vehicle Supply Equipment?

ChargePoint strongly supports DEQ's intention to allocate the maximum 15% to light-duty electric vehicle supply equipment (EVSE). Several states have already committed to 15% for EVSE as part of their mitigation plans, and Virginia has issued an RFP for charging stations associated with their 15% distribution.

4. What is the anticipated demand for specific types of diesel emission reduction projects not eligible under the VW settlement but otherwise eligible under DERA or other state programs?

ChargePoint has no comment on the anticipated demand for DERA-related projects.

5. *Should a certain percentage of available VW funds be allocated to each eligible project type and if so how should the percentage be determined?*

Beyond the 15% allocation to EV charging infrastructure, ChargePoint encourages the State to allot a significant portion of the remaining 85% to electric fuel project categories over other fuel types, which will lead to long-term transportation emissions reductions and increased efficiency.

Under the terms of the Environmental Mitigation Trust, funds used for transportation electrification projects in multiple categories may cover the cost of the vehicle/engine and associated charging infrastructure. ChargePoint notes that many of these technologies utilize a standard connector, which can increase economies of scale as the State procures supporting charging infrastructure across eligible project types. For example, investing in electric models and associated infrastructure could enable public light-duty fast charging stations to be utilized for bus charging and other fleet needs. And across applications in the same category, shuttle bus electrification programs could support regional, municipal, and school bus fleets.

6. *Should a certain percentage of available Mitigation Trust funds be reserved for government projects?*

ChargePoint would not recommend a specific percentage for government-owned or municipal projects, but we note the potentially higher coverage of Trust funds toward government-based projects. For electric vehicle infrastructure, municipal charging stations represent a significant portion of charging station demand, and publicly available charging stations in municipalities can provide an important amenity to local EV drivers and those passing through town. The funding program for EVSE can be tailored to best fit North Carolina's communities.

7. *Should funds be geographically distributed, and if so how?*

Light-duty electric vehicle infrastructure funding programs can be flexible in how they are distributed, whether they are solely responsive to the demand from the market and site hosts, targeted to specific use cases and geographically-based allocations, or a hybrid of factors for distribution.

Light-duty electric vehicle charging infrastructure projects can align with the State's goals for the EV charging sector and complement existing infrastructure. Existing deployments in North Carolina have focused around key municipalities and areas of higher density, but there are gaps to address in order to promote broader EV adoption in all communities. DEQ should determine that a funding program be designed to target areas that will drive the greatest near- and long-term utilization of charging assets. Focusing on utilization will significantly contribute to the success of the State's deployment. Additionally, the program can be structured to concentrate on local emissions reductions and prioritize specific non-attainment zones.

In general, ChargePoint recommends that DEQ focus on Level 2 charging stations for municipalities and local points of interest, where people may dwell for longer periods of time. For DC fast charging stations, we suggest targeted sites at regular intervals along the major corridors, specifically those that are not designated as FHWA Alternative Fuels Corridors under the FAST Act, notably I-95 and I-77. We can also assess traffic patterns to determine the right corridors for development.

8. *Should governmental entities be required to provide matching funds and if so, how much?*

No, governmental entities should not be required to provide matching funds for projects. ChargePoint does note that for electric vehicle supply equipment, it is important to have site hosts have skin-in-the-game. This will ensure that site hosts are invested in the station and will have an interest in its success as a project, and consequently, the DEQ can preserve a portion of its match for other projects.

9. *Should DEQ establish a minimum project size and if so, what size?*

ChargePoint supports a flexible program that is designed to accommodate a range of project sizes and types of EVSE. DEQ should establish baseline eligibility criteria for stations supported by Trust funding, including:

- Level 2 and DC fast charging only
- Smart, networked charging stations
- Standard port connectors
- Energy Star Certified
- Capable of data collection for the State's environmental mitigation tracking and transportation planning
- Minimum of 5 years of operation guaranteed
- Requires an ongoing maintenance agreement

10. *In addition to evaluating a proposed project's total cost effectiveness (\$/ton), what other key factors should DEQ consider when evaluating projects?*

For light-duty EVSE, ChargePoint recommends an evaluation of the baseline criteria outlined in Question #9 above, and also account for priority scoring based on additional criteria DEQ deems appropriate. Those additional criteria may include a) consideration of desired locations, b) segment of the market served (workplace, retail, multi-unit dwelling, etc.), c) redundancy with existing deployments, and d) economic development contribution.

11. *What other feedback do you have on project evaluation and/or scoring criteria?*

ChargePoint looks forward to being a resource for DEQ as it develops objectives for its mitigation plan.

12. *What publicly available tool(s) should be used to quantify anticipated emission reductions/offsets for eligible mitigation projects? What, if any, additional resources should be provided and made available?*

ChargePoint has developed an empirical and verifiable methodology for accounting for NO_x emissions reduction from transportation electrification projects, and we also currently track our carbon emissions reduction data as well. This approach is based around anticipating/measuring consumption at charging infrastructure, and we note that the following methodology cannot be used if stations are not networked.

We assume that there is a one-to-one ratio between the number of EV charging sessions delivered and the number of internal combustion engine fueling sessions displaced. ChargePoint used the following assumptions to calculate the total petroleum displacement and NO_x reduced:

Grams of NO _x per mile driven ¹	0.693
Miles per kWh (EV average)	3.2

Based upon our study of existing DC fast charger usage data network-wide, ChargePoint estimates that each DC fast locations will conduct an average of two sessions per day, with an average of 19 kWh delivered at each session. Similarly, for Level 2 stations in the region, ChargePoint estimates that each Level 2 charging spot will conduct an average of one charging session per day in the initial year of operations with 8 kWh delivered at each session. Once DEQ knows the total EV charging stations installed, a simple calculation can deduce the NO_x mitigation metric from the number of kWh in anticipated charging sessions.

From publicly available data, DEQ would only require an understanding of NO_x emissions derived from the State’s electric power resources. This information is available on the U.S. Energy Information Administration’s website.²

13. What methods could DEQ employ to reduce barriers and increase participation in future solicitations for projects?

In ChargePoint’s experience with Environmental Mitigation Trust activities in other states, public, in-person workshops can be highly effective in encouraging a public discourse around use of Trust funds and demand for certain project types. But, we also believe that DEQ should not delay in its consideration of funding programs and draft designs.

14. What information would be most valuable for stakeholders interested in submitting projects and what is the best way to communicate those?

We believe that industry would benefit from certainty surrounding the funds, including priority for some eligible mitigation action categories. Therefore, we encourage DEQ to release a draft outline or draft text of the mitigation plan once high level details are approved. In particular, several states have already indicated publicly that the maximum 15% for charging will be included in their mitigation plans. We hope that DEQ can communicate the same commitment publicly, which will attract private investment and increased participation in upcoming programs. Those announcements took several forms, but most chose to include those details in a draft plan.

Section 3 – Submitting Your Project Information

In lieu of specific project information, ChargePoint would like to offer a proposed structure for an efficient funding program for electric vehicle charging infrastructure. We believe that this basic structure will increase charging deployments near-term, foster the State’s long-term market for EVSE, and target specific areas and segments for deployments statewide. In establishing set prerequisites for charging infrastructure equipment, zones of development, and operations, DEQ can activate the competitive market to meet the State’s needs.

¹ U.S. Environmental Protection Agency. *Average Annual Emissions and Fuel Consumption for Gasoline-Fueled Passenger Cars and Light Trucks Emission Facts*. National Service Center for Environmental Publications, October 2008.

² www.eia.gov

In our proposed structure, DEQ would set specific parameters for an open, competitive grant program. We believe that this program design will allow the competitive market for charging infrastructure to drive demand from eligible site hosts, while remaining responsive to the State's priorities for Trust funding. Here, we suggest a rough outline of grant funding considerations, with more specific detail on project requirements that would best benefit the State.

Light-Duty EV Charging Station Installation Grant Program

Program Structure

DEQ will establish an overarching competitive grant structure to align with a) the requirements for NO_x emission reductions per the VW Consent Decree, and b) the State's goals for transportation electrification and associated environmental benefits:

- Define eligible applicants for grant projects
- Define desired geographic focal points for project development, and radius from any focal points (e.g. I-95, within 2 miles from corridor)
- Define charging station technology desired
- Define any funding caps for a single applicant
- Define priority consideration for low-income infrastructure deployment in low-income/disadvantaged communities

Project Identification and Design

DEQ will evaluate EV charger incentive projects through a list of weighted evaluation criteria. Outside of baseline requisite eligibility as set forth below, consideration for priority projects may be based on the following factors:

- Facility (e.g., corridor, public, workplace, multifamily, etc.)
- Geographic region (e.g., regions, counties, cities, etc.)
- Socioeconomic (e.g., low-income)
- Environmental (e.g., poorest air quality)

Eligible Applicants

An eligible Applicant must be a workplace, commercial, multiunit dwelling, not-for-profit entity or public agency with publicly accessible locations for eligible charging infrastructure. Eligible applicants must agree to a reporting mechanism or data sharing agreement with DEQ, specifically to provide data on electricity consumption (to calculate NO_x mitigation contribution) and utilization patterns.

Equipment Requirements

DEQ will define equipment requirements. Equipment requirements may include:

Level 2 charging stations

- Must have J1772 connector(s)
- Must 6.2 kW capable or greater
- Must be networked (minimum one-year networking agreement)
- If payment is required, must accept multiple forms of payment
- Must be certified by the Underwriters Laboratories, Inc. (UL), or equivalent safety standard
- Must be ENERGY STAR Certified

- Must include a one-year maintenance agreement that guarantees 95% up time or greater, 24 hours a day, seven days a week

DC fast chargers

- Must have CHAdeMO and SAE Combo connectors
- Must be 62.5 kW capable or greater
- Must be networked (minimum five-year agreement)
- If payment is required, must accept multiple forms of payment
- Must be certified by the Underwriters Laboratories, Inc. (UL), or equivalent safety standard
- Must include a five-year maintenance agreement that guarantees 95% up time or greater, 24 hours a day, seven days a week

Grant Project Funding Levels

The Recipient will define funding levels for each grant project by facility type. Funding levels may include:

- Up to 100% funding for government-owned facilities
- Up to 80% funding for DC fast charging corridor facilities
- Up to 80% funding for commercial facilities
- Up to 60% funding for multifamily facilities
- Up to 60% funding for workplace facilities

###

December 31, 2017

The Honorable Michael S. Regan
Secretary
Department of Environmental Quality
217 West Jones Street
Raleigh, NC 27699-1641

ATTN: NC VW Settlement RFI
Division of Air Quality – Mobile Services
217 West Jones Street
1641 Mail Service Center
Raleigh, NC 27699-1641

Dear Secretary Regan:

RE: Maximizing Settlement Fund Allocation for Charging and Hydrogen Refueling Infrastructure

The Association of Global Automakers (Global Automakers) represents the U.S. operations of international motor vehicle manufacturers, original equipment suppliers, and other automotive-related trade associations. In 2016, international automakers manufactured 62% of all new motor vehicles and 81% of green technology vehicles sold in North Carolina.

Global Automakers and our members have a longstanding commitment to improving air quality, reducing greenhouse gas emissions, and increasing fuel efficiency. Our members are investing heavily in alternative fuel and green technologies, including being the first to successfully launch hybrid electric vehicles 20 years ago and since then plug-in and fuel cell electric vehicles. We are proud that the number of electric-drive vehicles, in a variety of options and price points, are increasing every year.

Under Appendix D of the Volkswagen settlement, North Carolina is due to receive \$92 million, which can be used for a variety of environmental-based projects. A maximum of 15% of this money, or \$13.8 million, can be used for the acquisition, installation, operation, and maintenance of electric vehicle infrastructure.

Global Automakers urges the State of North Carolina to allocate the full 15% towards this effort and to support all electric vehicle infrastructure – charging stations *and* hydrogen refueling stations. The state needs to establish a strong foundation for electric vehicles by expanding its network of charging and building out a network of hydrogen refueling stations to support sales of electric vehicles. Increasing available infrastructure is critical to the state's ability to advance electrification. Range anxiety is a significant impediment to sale of electric vehicles.



Year to date in 2017, North Carolina's electric-drive vehicle sales made up of 0.41% of new vehicles sold. Investment in electric vehicle infrastructure responds to this problem while furthering air quality and supporting customers in your state that choose to buy an electric vehicle.

Should you have any questions, please do not hesitate to contact us. Thank you for your consideration of our request, and your continued support of electrification.

Sincerely,

A handwritten signature in blue ink, appearing to read "D. Porter", with a long horizontal flourish extending to the right.

Damon Shelby Porter
Director
State Government Affairs

A handwritten signature in blue ink, appearing to read "J. Rege", with a long horizontal flourish extending to the right.

Julia M. Rege
Director
Environment and Energy



December 30, 2017

NC Division of Air Quality – Mobile Sources
217 West Jones Street
1641 Mail Service center
Raleigh, NC 27699-1641

To whom it may concern:

North Carolina's electric cooperatives appreciate the opportunity to submit the attached response to the Request for Information (RFI) issued Nov. 21, 2017 by the North Carolina Department of Environmental Quality (NC DEQ). While one or more North Carolina-headquartered electric cooperatives may respond individually, the NC Association of Electric Cooperatives is submitting a response on behalf of its 26 member electric cooperatives.

North Carolina, through policy and practice, has shown a strong commitment to reducing emissions of nitrogen oxide (NOx) and other air pollutants over the last two decades. The funds derived from the Volkswagen State Mitigation Trust can provide additional resources to facilitate further NOx emissions reductions, while also promoting the adoption of zero-emission vehicles (ZEV) and corresponding EV charging infrastructure.

The attached response outlines North Carolina's electric cooperatives' vision for transformational investment that benefits all North Carolina citizens across the state.

Please feel free to contact us with any questions. We look forward to working with you.

A handwritten signature in black ink that reads "Nelle P. Hotchkiss".

Nelle Hotchkiss
Senior Vice President, Corporate Relations
NC Association of Electric Cooperatives
(919) 875-3079

December 30, 2017

NC VW Settlement RFI
Division of Air Quality – Mobile Sources
217 West Jones Street
1641 Mail Service Center
Raleigh, NC 27699-1641

Section 1: Project Applicant Information

Company/Agency/Organization Name: North Carolina Association of Electric Cooperatives

Contact Person Name: Nelle Hotchkiss, SVP of Corporate Relations

Government/Non-Government: Non-Government

Mailing Address: Post Office Box 27306, Raleigh, NC 27611-7306

Phone Number: (919) 875-3079

Email Address: Nelle.Hotchkiss@ncemcs.com

Executive summary

The building of EV charging infrastructure in urban areas has been maturing in our state since 2011; rural areas should not be left behind. North Carolina's electric cooperatives, which serve diverse rural and suburban communities in 93 counties, are implementing strategies to provide EV charging that encourages further EV adoption and contributes to emissions reduction goals.

Any Mitigation Plan adopted by NC DEQ should set aside funds for (1) building out an EV charging network in rural areas served by the electric cooperatives, and (2) replacing and/or converting co-op service vehicles (e.g., bucket trucks) and other rural community vehicles (e.g., school buses) to ZEV. These rural projects are described in greater detail below.

A Mitigation Plan that sets funds aside for the foregoing projects will not only advance mitigation of harm caused by the offending VW vehicles, but it will also propel North Carolina tourism and generate commerce and economic development opportunities in our state's rural communities.

Cooperatives at a glance

By merging their mission of service with a commitment to innovation, North Carolina's electric cooperatives are building a brighter energy future for 2.5 million North Carolinians. Beyond providing electricity, each of the 26 not-for-profit cooperatives is investing in their communities and delivering new energy solutions to improve the quality of life for cooperative consumers in 93 North Carolina counties.

As locally owned and operated businesses, electric cooperatives provide solutions that match the needs of the areas and the consumers they serve. Those areas are diverse, ranging from

suburban to rural with vastly differing demographics and socioeconomic statuses, frequently with lower income and higher poverty than state and national averages (as demonstrated in the chart below).

Demographic Data for North Carolina Co-ops (26)			
Population	Co-op	State	National
2011 Residential Meters/Households	905980	3807990	118025427
Average Household Size	2.5	2.48	2.58
Estimated 2011 Population	2267339	9710573	312796426
Income and Employment	Co-op	State	National
Mean HH Income	62939	67514	77190
Poverty	Co-op	State	National
2015 Poverty Rate	17.4%	16.4%	14.7%

Sources: EASI 2012/2015, EIA 2011/2015, NRECA 2012, RUS 2009

Many of the communities served by cooperatives not only lack growth and economic development opportunities, but they also are situated in counties with high point source NOx emissions.

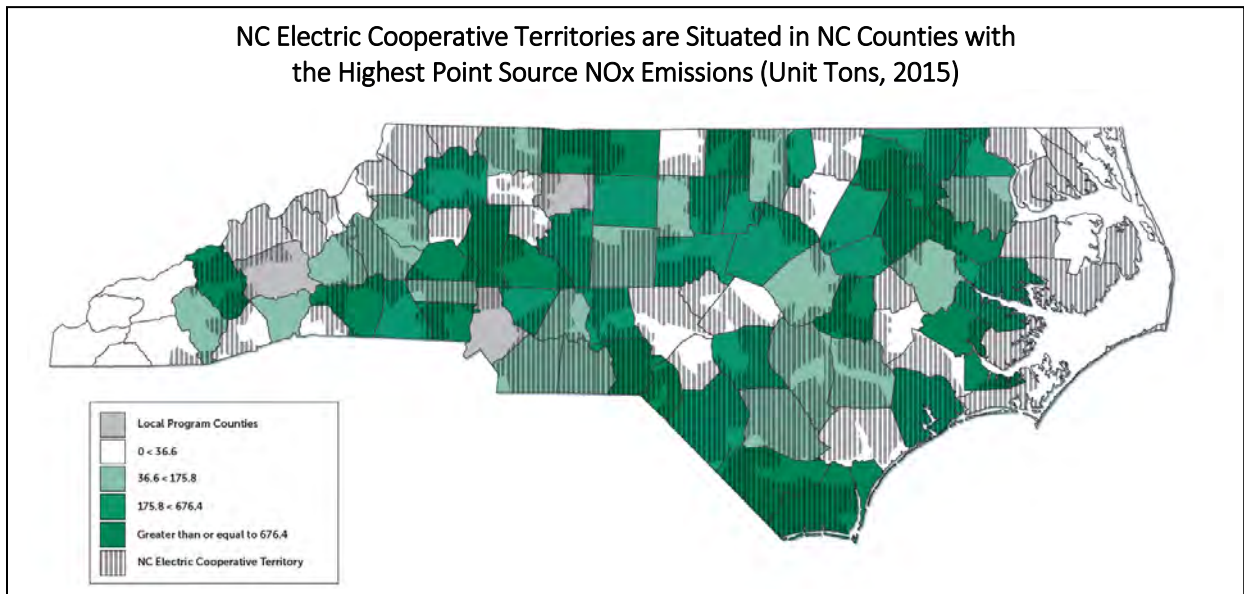

Sources: NCEMC, DEQ website

(<https://xapps.ncdenr.org/aq/ToxicsReportServlet?ibeam=true&year=2015&physical=byCounty&overrideType=All&toxics=265&sortorder=3&viewreport=View+Report>)

Although the high NOx emissions can be predominantly attributed to important industrial facilities that provide jobs in rural areas, the impact of NOx emissions on these rural communities can be mitigated by the adoption of ZEV. This is among the reasons North Carolina’s electric cooperatives are committed to promoting ZEV and continuing to build EV charging infrastructure in the rural areas they serve.

The electric cooperatives' longstanding commitment to ZEV promotion

North Carolina's electric cooperatives were among the first in the state to recognize that ZEV were bound to achieve significant market penetration in the coming years. In 2010, North Carolina's electric cooperatives began surveying co-op consumers about their interest in ZEV.

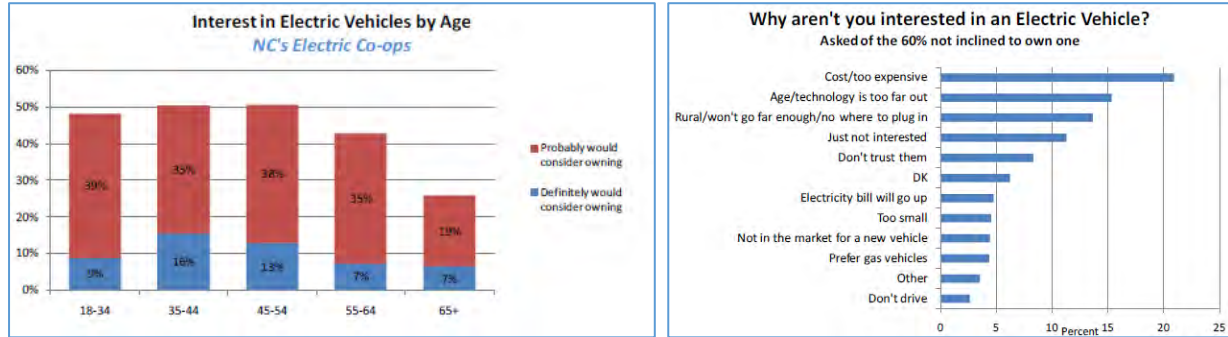

Source: 2010 National Survey on the Cooperative Difference – North Carolina's Electric Cooperative Edition, pp. 64, 67, TSE Services (2011)

In 2011, North Carolina's electric cooperatives were one of nearly 50 public and private sector members to support the creation of the NC Plug-In Vehicle Taskforce. The Taskforce developed the state's first Plug-in EV Readiness Plan to help navigate adoption barriers to EVs and to develop a plan for coordinated deployments of EV charging infrastructure.¹

More recently, in 2016, North Carolina's electric cooperatives partnered with Advanced Energy to research the electric vehicle market, understand consumer trends and survey co-op customers. The resulting report – [Electric Vehicle Strategies for North Carolina's Electric Cooperatives](#) – yielded key insights such as the following:

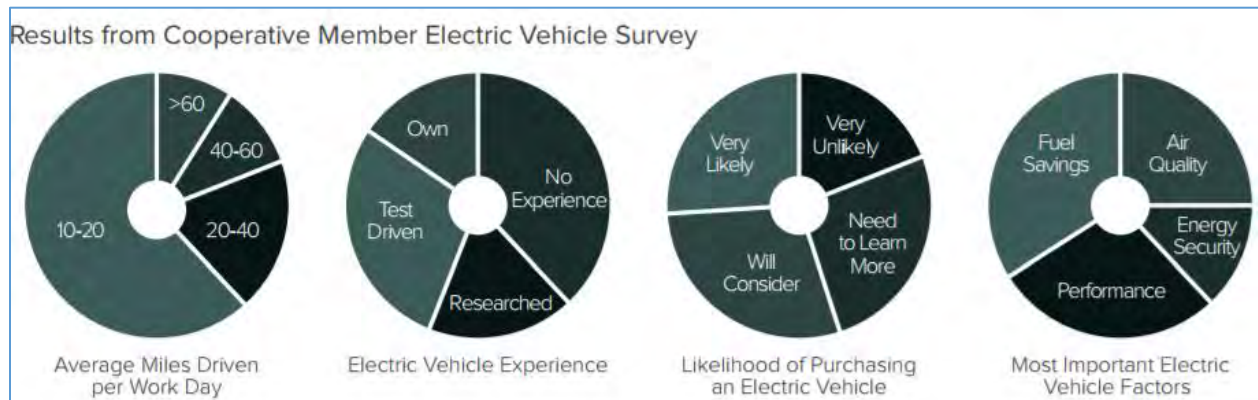

The report also prompted the cooperatives to further engage and support ZEV activities.

¹ Plug-In Electric Vehicle (PEV) Roadmap For North Carolina, Version 1.1 (February 2013) (accessible at http://www.pluginnc.com/wp-content/uploads/2016/06/7-NCPEVRoadmap_April2014_v2.pdf)

The sustained commitment of North Carolina’s electric cooperatives to ZEV activities and to EV charging infrastructure deployment are beginning to bear fruit. For example:

- The NC Association of Electric Cooperatives, with the assistance of Advanced Energy, recently produced an educational video to promote EVs. [Watch the video here.](#)
- To support the electric cooperatives’ advancement of a ZEV charging infrastructure, the Tarheel Electric Membership Association (TEMA), an equipment supply cooperative owned by North Carolina’s electric cooperatives, has negotiated a charging station purchasing agreement with one of the nation’s largest manufacturers – ChargePoint. The agreement allows the cooperatives to benefit in aggregate from economies of scale and leverage our private infrastructure investment. To date, North Carolina’s electric cooperatives have installed more than a dozen chargers across the state with more set to be added (see Section 3, Project 1 below).

- Blue Ridge Energy, like many NC cooperatives, utilized grant funding from the Duke Energy EPA settlement to procure and install two Level 2 charging stations in downtown Blowing Rock and West Jefferson in partnership with those towns. Blue Ridge Energy also purchased a 2017 Chevy Bolt for use as their first all-electric fleet vehicle and wrapped the car to promote the benefits of EVs to its membership.



- Wake EMC, like other cooperatives, now offers a special rate as an incentive for members to charge their EVs at night during off-peak hours when there is less demand for electricity and it is therefore less expensive.
- Randolph EMC introduced a program called REVUP (Randolph EMC Electric Vehicle Utility Program), which provides a \$500 rebate for homeowners who have installed/wish to install a residential level 2 charging station. The program also includes a special rate for off-peak charging.
- EnergyUnited, a cooperative that serves 17 counties west of Winston-Salem has adopted a similar program and installed several charging stations.
- Brunswick EMC, which serves Columbus and Brunswick counties and our southern shore beaches, has invested in three level 2 charging stations and two fast charging stations. These stations are strategically located along travel routes to the beaches, as well as at beach

access areas, encouraging tourism to those counties. Brunswick EMC is currently collecting data which will provide an opportunity to track the origin of drivers, driving patterns and growth of use over time.

These examples demonstrate the electric cooperatives' early investment in and visible promotion of ZEV and EV infrastructure.

With the cooperatives' help, the 2011 Plug-in EV Readiness Plan kick-started the state's preparedness for ZEV and the current 7,441 registered EV drivers in the state. More than 1,000 existing public charging ports in North Carolina support the current population of EV drivers, but there remain significant geographical gaps in charging station availability, particularly in rural parts of the state. Absent concerted effort, these gaps will only become more exacerbated as ZEV deployment grows.²

Adoption of a Mitigation Plan that sets aside funds for the continuation of cooperatives' ZEV support efforts will not only mitigate the harm caused by the offending VW vehicles, but it will also propel North Carolina tourism and generate commerce and economic development opportunities in our state's rural communities.

Section 3: Project Information

The Mitigation Plan adopted by NC DEQ should set aside funds for (1) building out an EV charging network in rural areas served by the electric cooperatives, and (2) replacing and/or converting co-op service vehicles (e.g., bucket trucks) and other rural community vehicles (e.g., school buses) to ZEV.

1. Build out of a rural EV charging network

Mitigation Project Category: Light Duty (LD) zero emission vehicle (ZEV) Supply Equipment (Level 1, Level 2, or fast charging equipment)

Project Summary: Absence of charging infrastructure presents a barrier to ZEV adoption. Installing appropriate charging infrastructure in rural areas will encourage ZEV adoption and mitigate the impact of point source NOx emissions on rural communities, as illustrated in Section 1 above (see also the NOx reduction estimates below).

² As new vehicle models hit the market and purchase prices decline, a major charging station manufacturer predicts North Carolina will ascend to third in the nation for ZEV growth. Source: ChargePoint (with data provided by IHS Markit through Q3 2016)

North Carolina’s electric cooperatives enthusiastically encourage NC DEQ to award the full 15 percent allocation available under the settlement to ZEV charging infrastructure. Moreover, from this 15 percent allocation, the Mitigation Plan should set aside at least \$1,144,000 to support build-out of an interconnected and statewide public charging network of strategically-located fast charging and Level 2 charging stations across 26 cooperative territories.

Setting aside at least \$1,144,000 for this project better leverages (i) the VW State Mitigation Trust funds themselves because this project involves cost sharing (see *Proposed Project Benefit* below) and (ii) the existing sources of support available to areas like Raleigh, Charlotte and Wilmington. Setting aside such funding for this project also promises the co-benefits – beyond NOx emission mitigation – of tourism attraction and economic development opportunities in our state’s rural communities (see *Beyond NOx: Benefits to NC tourism* inset below).

Beyond NOx: Benefits to NC tourism

The map below demonstrates the electric cooperatives’ vision for promoting tourism through a ZEV charging network.

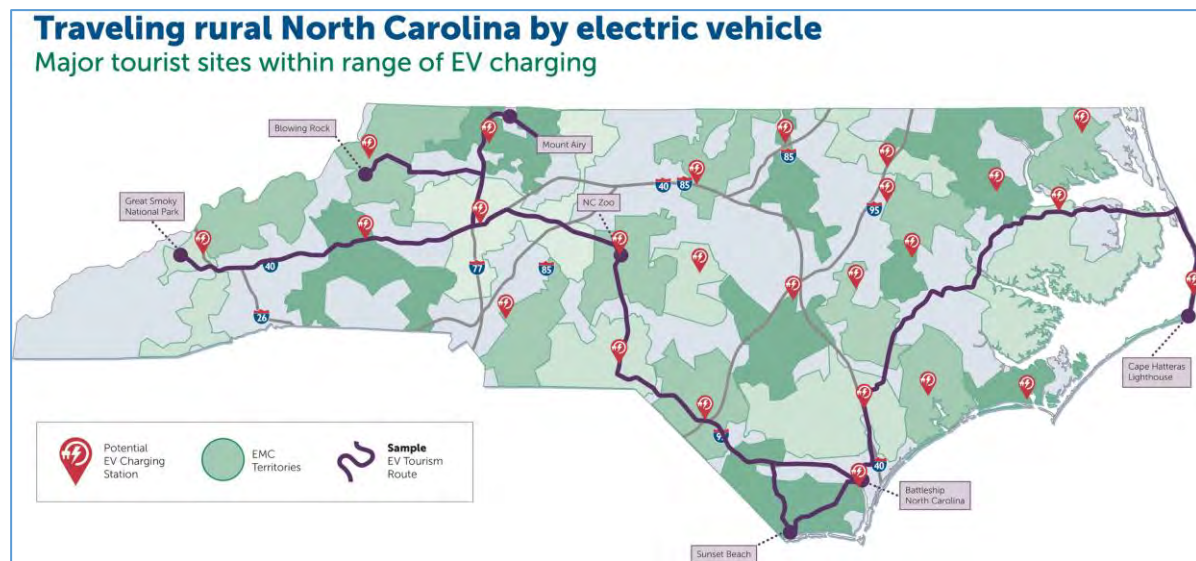

North Carolina’s electric cooperatives envision a future where our citizens and our economy benefit from an extensive and integrated statewide electric transportation infrastructure. Tourism is the sixth largest North Carolina industry, providing more than \$22 billion annually to the state. It is also a significant source of revenue to most rural counties, which include our waterfront and mountain communities, as well as many tourist destinations. Travelers depart from interstates to reach famous destinations, like Grandfather Mountain, Mount Airy (Mayberry), the NC Zoo and the Ocracoke Lighthouse. These destinations, and many more, are in cooperative served areas, and every major road in the state traverses electric co-op territory, connecting rural to urban, mountains to coast and every point between. Yet, with the exception of the charging stations cooperatives are installing, these areas are charging deserts, limiting ZEV drivers from exploring our state and visiting its unique destinations. Thoughtfully deployed ZEV charging sites will propel tourism and it will also catalyze rural economic development by encouraging the ZEV driving public to charge in areas where they can also shop, dine and explore -- all while decreasing NOx emissions and helping achieve clean air goals.

Thus, inclusion of Plan funding for this project better ensures benefits to the state as a whole, including rural areas.

Proposed Project Benefit:

One public 50kW fast charging station is expected to fuel 200,000 to 400,000 electric vehicle miles annually for an average annual emissions reduction of 25 pounds NOx and 40 short ton GHG (per station). One 10kW Level 2 charging station can be expected to fuel between 40,000 and 80,000 electric miles annually. These benefits are directly measurable and will increase over time as station utilization increases and consumer adoption continues to rise. In addition, public EV charging stations stimulate the adoption (i.e. consumer purchase) of electric vehicles by providing a range extending opportunity and alleviating the biggest barrier to EV acceptance, range anxiety. Public charging stations can compound the measurable air quality benefits by serving multiple vehicles with each station and supporting alternative fuel integration and use across our communities.

Product Details	Per Unit Cost	Estimated Annual (effected) Mileage	Annual GHG Reduction (short tons)	Annual CO2 Reduction (short tons)	Annual NOx Reduction (lb)	Service Life (years)	Project Nox Reductions (lb)	Cost Effectiveness per Unit (\$/Nox Lb)
50 kW DC Fast Charge Station, includes equipment purchase and installation. (Based on 50% utilization factor).	\$50,000	219,000	37.9	34.8	25.1	15	377.1	\$ 1,989
Level 2 AC Charging Station (10kW), includes equipment purchase and installation. (Based on 50% utilization factor).	\$5,000	43,800	7.6	7.0	5.0	15	75.4	\$ 994

Proposed Project Capital Cost: 26 DCFC (50 kW) Stations x \$50,000 = \$1,300,000; 26 Level 2 (10 kW) Stations x \$5,000 = \$130,000. Total Expected Cost: \$1,430,000.

Proposed Project Cost to Plan (After Cost Sharing): \$1,430,000 x 80% = \$1,144,000³

Project Benefit: GHG reductions – 16,302 short tons; NOx reductions 5.9 short tons.

Methodology:

Projected emissions reductions calculated using Argonne National Laboratory Greet Fuel Cycle Model_1_2017 – Well to Pump Emissions Calculator.⁴ The model compares emission values for alternative fuels including light-duty gasoline and all-electric models.

³ Consistent with the strictures of Appendix D-2 to the Partial Consent Decree, the cooperatives’ project seeks “up to 80% of the cost to purchase, install and maintain [fast charging and Level 2 charging] equipment that will be available to the public at a Non-Government Owned Property.”

⁴ https://greet.es.anl.gov/greet_1_series

2. Replacing and/or converting co-op service vehicles and other rural community vehicles

Mitigation Project Categories:

(a) Repower or replacement of Class 4-7 Local Freight Trucks with 1992-2009 model year engines and a GVWR between 14,001 and 33,000 lbs

(b) Class 4-8 School, Shuttle, or Transit Buses with model year 2009 or older engines and a GVWR greater than 14,001 lbs. and used for transporting people

Project Summary: In addition to the installation of charging infrastructure in cooperative-served areas, North Carolina's electric cooperatives are also interested in (a) repowering or replacing older, diesel Class 4-7 bucket trucks and light duty trucks, which amass significant miles daily, and (b) supporting rural local government efforts to replace traditional diesel school buses with electric buses. North Carolina's electric cooperatives have voiced support for local government replacement of traditional diesel school buses with electric buses because this change would reduce emissions that improve air quality and the health of our children.

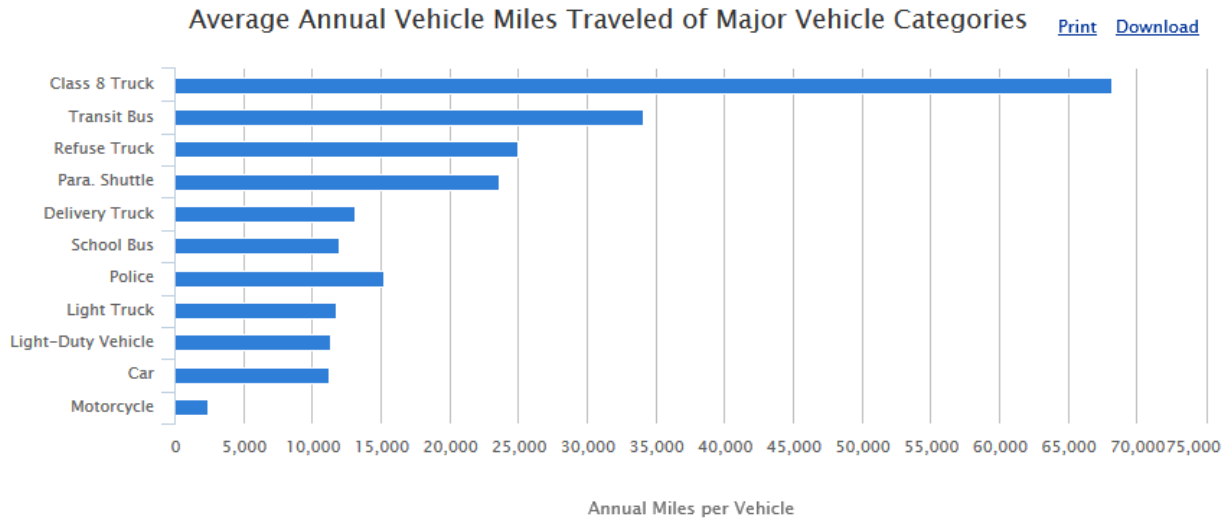

Last updated: June 2015
Printed on: December 26

Source: [Federal Highway Administration](#)

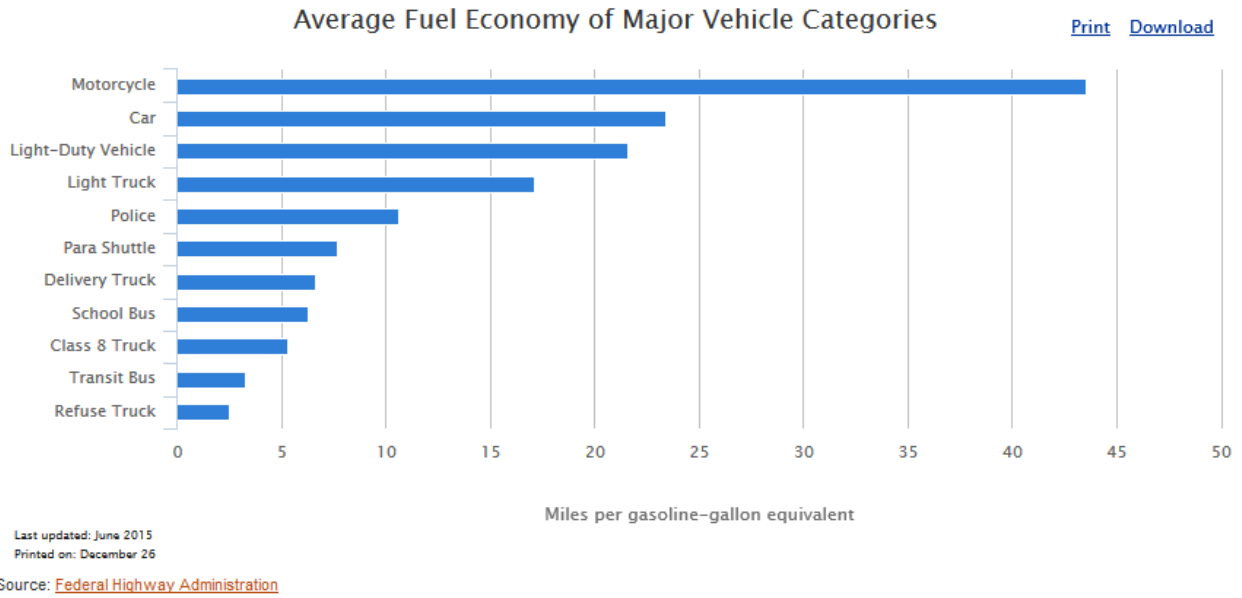

Repower or replacing co-op fleet vehicles

According to a 2015 NC DAQ report, the top counties for point source NOx emissions include Catawba, Columbus, Halifax, Haywood, Iredell, Martin, Person, Rutherford and Scotland counties, all of which are served by electric cooperatives.⁵ The initial NOx reduction benefits created by replacing bucket and light duty trucks will be amplified as co-ops use these vehicles to promote ZEV awareness and adoption.

Replacing diesel trucks will also serve as a case study to determine the vehicles' ability to perform in routine and emergency restoration situations, which are often in difficult terrain. NC DEQ considering awards to Class 4-7 bucket truck replacement will provide an opportunity to confirm their performance advancing adoption across the state's utilities.

Support of Local Government and School Systems

There are currently 14,104 diesel school buses on North Carolina roads today. Schools buses, travel over 181,285,181 route miles in North Carolina per year.⁶ By reducing emissions from selected routes to zero, localities can maximize air quality benefits enabled by this funding.

The advantages of electric school buses include significantly lower operating costs, as well as preventing children, who are most vulnerable to air pollutants, from breathing diesel exhaust.

⁵

<https://xapps.ncdenr.org/daq/ToxicsReportServlet?ibeam=true&year=2015&physical=byCounty&overrideType=All&toxics=265&sortorder=3&viewreport=View+Report>

⁶ Public Schools of North Carolina, State Board of Education/Department of Public Instruction, www.LoveTheBus.com

Purchasing costs, however, are significantly higher than their traditional diesel counterparts. The opportunity and benefits for replacing diesel buses with ZEV buses will grow significantly as battery technology evolves, driving distances per charge improve and costs decrease. The cooperatives are currently considering ways to support this replacement and are exploring additional funding opportunities from federal sources.

The use of the electric buses would also provide an opportunity to advance the electric vehicle market through education and advocacy opportunities. We know from previous experience with alternative vehicle technology development, the best way for citizens to understand alternative vehicle technologies is to experience them. NC electric cooperatives recommend NC DEQ consider funding pilot projects working with local government in rural counties to demonstrate the viability of a transition to all-electric school bus fleets. Data can be gathered and shared across school systems.

The data gleaned from these pilot projects would also allow local governments and cooperatives to work together to evaluate other, larger scale vehicle-to-grid opportunities. Charging clusters would be required to support the school bus replacement effort, and cooperatives would work with a charging manufacturer to design the cluster, monitor its performance and impact on the grid.

Charging multiple buses overnight will also provide an asset to the hosting cooperative, and that cooperative can explore calling on that asset if needed. Currently in PJM and ERCOT power markets, there are already pilots testing the use of clustered buses for frequency regulation allowing utilities to provide balancing in areas of high renewable penetration. [This article provides further details.](#)

Proposed Project Benefit:

Well to Wheel - Annual Reductions by Vehicle Type	Petroleum Use (barrels)	GHGs (short tons)	CO2 (short tons)	NOx (lb)
Passenger Car - Gasoline to BEV	12.4	4.6	4.2	2.7
Passenger Car - Diesel to BEV	14.9	5.8	5.4	3.4
Light Commercial Truck - Gasoline BEV	13.7	0.9	0.8	3.4
Light Commercial Truck - Diesel BEV	16.5	2.3	2.1	16.8
Light Commercial Truck - Gasoline to PHEV	5.6	2.9	2.7	3.4
Light Commercial Truck - Diesel to PHEV	8.4	4.3	4.0	16.8
School Bus - Diesel to BEV	42.3	4.7	4.3	25.1
Transit Bus - Diesel to BEV	282.4	117.1	109.7	81.9

**STATE OF NORTH CAROLINA
DEPARTMENT OF ENVIRONMENTAL QUALITY
217 WEST JONES STREET, RALEIGH, NC 27603
P. O. BOX 1641, RALEIGH, NC 27699-1641**

REQUEST FOR INFORMATION (RFI)

**VOLKSWAGEN CONSENT DECREE
ENVIRONMENTAL MITIGATION TRUST PROJECT IDEAS**

November 21, 2017

Note: This RFI is not a solicitation for projects. Submitting a response to this RFI is voluntary and is not a prerequisite to participating in projects for Volkswagen (VW) environmental mitigation trust funds.

1. INTRODUCTION

RFI Objective:

The State of North Carolina expects to receive \$92,045,658 from the Volkswagen Mitigation Trust between 2018 and 2028. These funds represent a significant opportunity to mitigate the environmental harm caused by the offending VW vehicles and to reduce air pollution in North Carolina. The North Carolina Department of Environmental Quality (DEQ) will administer these funds through a state mitigation plan. The objective of this RFI is to gather information to help DEQ determine the best use of the funds for North Carolina.

DEQ is seeking input from governmental and non-governmental entities on the type and scope of projects that can achieve these goals and measure results.

Background:

In 2016, a court approved a partial settlement and consent decree resolving allegations that VW violated the Clean Air Act (CAA) by selling diesel motor vehicles equipped with devices designed to cheat on federal emissions tests. Related consent decrees for VW can be found at: <https://www.epa.gov/enforcement/third-partial-and-301-secondpartial-and-201-partial-andamended-consent-decree>.

The State Mitigation Trust and the Indian Tribe Mitigation Trust were both approved by Court Order which established October 2, 2017 as the Effective Date for each Trust States have until December 1, 2017 to file paperwork with Wilmington Trust to become a beneficiary of trust.

These settlement agreements require VW to establish and fund an environmental mitigation trust to fund projects expected to fully mitigate the lifetime excess nitrogen oxide (NO_x) pollution emitted by VW vehicles that violated the CAA.

DEQ is developing a proposed draft mitigation plan, which specifically describes:

- Funding priorities to guide the planning, solicitation, and project selection processes;
- Categories of eligible mitigation projects to achieve; the goals and how much funding should be allocated to each type;
- The potential benefit of these projects on air quality in areas that bear a disproportionate share of the air pollution burden within its jurisdictions;
- Anticipated ranges of emission benefits that would be realized by implementation of the eligible mitigation projects identified in the mitigation plan; and
- Explanation of processes used to obtain public input on the mitigation plan.

State mitigation plans must be approved by the Trustee for the VW State Mitigation Trust. DEQ expects that funding for eligible VW mitigation projects may be available in late 2018.

2. INFORMATION REQUESTED

DEQ invites interested entities to provide information on eligible mitigation projects, suggestions on funding and project selection priorities, and methods DEQ could employ to increase participation in future solicitations for air quality mitigation projects. For more information about eligible project types, please see the Environmental Protection Agency information: <https://www.epa.gov/sites/production/files/201610/documents/amended201partialcd.pdf>; Appendix D-2 (p. 209-220).

Note: DEQ is also seeking project ideas for the VW settlement Diesel Emissions Reduction Action (DERA) Option through this RFI. Information on the DERA Option can be found here: <https://www.epa.gov/cleandiesel/vw-settlement-dera-option-supportingdocuments>.

Interested stakeholders are requested to respond with information on the areas identified below.

Section 1 - Project Applicant Information

- Company/Agency/Organization Name:
Blue Ridge Energy
- Contact Person Name:
Jon Jacob, Energy Solutions Marketing Manager
- Government/Non-Government
Non-Government
- Mailing Address
PO Box 112, Lenoir, NC 28645
- Phone Number:
828 759 8956
- Email Address:
jjacob@blueridgeenergy.com

Blue Ridge Energy is at the forefront of driving the beneficial electrification of transportation in Western North Carolina. In 2017, Blue Ridge self-funded the installation of the first DC Fast Charger in our service territory; filling a significant gap in charging infrastructure along the 321 corridor between Hickory and Boone. The Fast Charging Station is covered by a Lumos solar canopy which has produced enough solar energy to completely offset the energy consumed during charging sessions. We also created a Smart Home lounge where EV drivers can relax in a comfortable living room environment while their vehicles recharge. The Smart Home lounge features the newest home automation technology like Amazon Alexa and Google Home which both control a large TV, mini-split HVAC and an electric fireplace.

Blue Ridge also utilized grant funding from the Duke Energy EPA settlement to procure and install two Level 2 EV Charging stations in downtown Blowing Rock and West Jefferson in partnership with those towns. Blue Ridge also purchased a 2017 Chevy Bolt for use as our first all-electric fleet vehicle and wrapped the car to promote the benefits of EVs to our membership.



Blue Ridge Energy believes that EVs are at the core of our mission to make life better for the members we serve. We estimate the average driver would save \$600-700 a year driving an EV versus the cost to fuel a similar vehicle powered by gasoline. Reducing gasoline vehicle emissions is also vital to preserving the natural beauty that brings thousands of tourists to the Blue Ridge Parkway, Grandfather Mountain, ski resorts, hiking trails and rivers each year. The savings on fuel and maintenance enjoyed by electric vehicles owners become available for discretionary spending that drives economic growth and supports local businesses.

Many rural electric cooperatives are faced with a challenging climate of low meter growth and declining kWh sales due to increasingly efficient devices and appliances. At home overnight electric vehicle recharging is vital for the future of all utilities since it can be accommodated during periods of low demand and managed charging allow the EV batteries to potentially be used as a grid resource for load reduction or to absorb excess renewable generation.

<https://www.greentechmedia.com/articles/read/how-utilities-can-harness-electric-vehicles-as-flexible-loads>

As a non-profit electric cooperative, Blue Ridge is unable to leverage the Federal tax credit for new EV purchases. One strategy we are currently exploring is replacing aging fleet vehicles with used EVs. Low mileage Nissan Leafs are currently available at prices well below \$10,000. Building a stock of used EVs in our fleet would also allow us to loan them to members interested in the experience of driving an electric vehicle. Several electric coops across the country have

seen incredible EV adoption growth with this combination of installing EV charging infrastructure and loan programs.

<https://www.electric.coop/colorado-electric-car-borrow/>

Utilities, especially electric cooperatives, are transitioning away from only distributing and selling kWh to an energy services business model. Gaining experience owning and operating a fleet of electric vehicles helps our employees develop new skills working on EV maintenance and repairs. Local electric cooperatives would be well positioned to eventually serve as EV service centers and possibly as car lots to recondition and resell used EVs.

In 2018, we are planning to push for local and state building code requirements that all newly constructed housing and parking lots provide the conduit and electrical system capacity for EV charging stations. California, Washington state and Atlanta have all recently passed similar codes. By one estimate, the average cost of compliance would be around \$50, a fraction of the potential cost to residents who choose to install charging stations after a building is already constructed. Blue Ridge Energy would collaborate with industry allies like NC Building Performance Association, Plug-In NC, Chargepoint and our local governments to drive these requirements at a county level first.

Section 2 – VW Program and Solicitation Design Questions

Respondents should consider providing information in response to the following questions:

1. How should DEQ prioritize projects?

Funding the deployment of more Level 2/Level 3 charging station infrastructure will do the most drive EV adoption rates and improve air quality. In a Chargepoint study of suburban St. Louis, the addition of 10 EV charging stations yielded a 73% increase in the number of new EV purchases year over year. Prioritizing the deployment of funding to areas without significant EV charging infrastructure is important to avoid limiting the prospects of EV adoption in non-urban areas. Creating a state tax credit for new EV purchases while outside the proposed projects would also be an excellent way to encourage the beneficial electrification of transportation in NC.

2. What is the anticipated demand for each eligible project type?

Based on our experience with the Duke Energy EV Charging Infrastructure support project, we think the highest demand will be for EV charging station infrastructure. The \$1 million in funding available was completely distributed to 83 cities, counties and utilities who were wholesale or retail customers of Duke Energy and the selection process for projects only took a few months. The project resulted in 200 new EV charging stations and increased the availability of public EV charging stations by 30%. This program could serve as a useful model for how to distribute VW settlement funding.

3. The percentage of trust funds, if any, that DEQ should devote to Light Duty Zero Emission Vehicle Supply Equipment?

Blue Ridge Energy strongly believes that the best use of trust funds is the deployment of

a mix of Level 2/Fast Charging infrastructure to encourage EV adoption and further the beneficial electrification of transportation. While that percentage currently is capped at 15%, it is our position that limit should be reevaluated to allow for greater investment in LDZEV charging stations

4. What is the anticipated demand for specific types of diesel emission reduction projects not eligible under the VW settlement but otherwise eligible under DERA or other state programs?
5. Should a certain percentage of available VW funds be allocated to each eligible project type and if so how should the percentage be determined?
No. The entire trust fund should be made available for project proposals of all types and the proposals should be evaluated upon their merits and expected benefits
6. Should a certain percentage of available Mitigation Trust funds be reserved for government projects?
No. All projects should be evaluated upon their merits and expected benefits in terms of reducing emissions and promoting adoption of EVs. Reserving a portion of funding exclusively for government projects limits competition and will result in a sub-optimal distribution of funding
7. Should funds be geographically distributed, and if so how?
Funds should be deployed along major transportation corridors with the goal of creating a statewide fast charging network without gaps in rural areas.
8. Should governmental entities be required to provide matching funds and if so, how much?
We propose that the awarded funding cover the cost of hardware and installation of equipment and that the ongoing labor, operation and maintenance should be the responsibility of the awarded organization.
9. Should DEQ establish a minimum project size and if so, what size?
No. Setting a minimum project size would exclude some creative low-cost project proposals of trust funding.
10. In addition to evaluating a proposed project's total cost effectiveness (\$/ton), what other key factors should DEQ consider when evaluating projects?
**Current levels of EV charging infrastructure available in the geography served by the applicant.
The cost of interconnecting EV charging infrastructure to existing grid infrastructure and the potential effects during periods of peak demand, especially for Level 3 charging stations**
11. What other feedback do you have on project evaluation and/or scoring criteria?
12. What publicly available tool(s) should be used to quantify anticipated emission reductions/offsets for eligible mitigation projects? What, if any, additional resources should be provided and made available?
Developing a simple online calculator to estimate avoided emissions per EV/ EV Charging Station that has variable inputs for generation mixture depending on the wholesale energy supplier would be extremely helpful
13. What methods could DEQ employ to reduce barriers and increase participation in future solicitations for projects? **Setting up an online portal for project proposals and creating**

a working group consisting of EV owners, manufacturers, utilities (IOU, Coop, Muni), charging network operators, etc. to collaborate and establish best practices.

14. What information/resources would be most valuable for stakeholders interested in submitting projects and what is the best way to communicate those?

Section 3 – Submitting Your Project Information

Identify Applicable Eligible Mitigation Project Category:

1. Install Light Duty (LD) zero emission vehicle (ZEV) Supply Equipment (Level 1, Level 2, or fast charging equipment) **\$350,000**
2. Repower or replacement of Class 4-7 Local Freight Trucks with 1992-2009 model year engines and a GVWR between 14,001 and 33,000 lbs with **Hybrid Bucket Truck \$200,000**

Project Summary:

Briefly describe the proposed project, including:

- Geographic area where vehicles/vessels/engines are operated (e.g., city/cities, county/counties, and/or neighborhoods)
Northwestern NC. Caldwell, Watauga, Ashe, Alleghany, Alexander, Avery & Wilkes Counties. Lenoir, Blowing Rock, Boone, West Jefferson, Sparta. 321 Corridor, 421 Corridor, Blue Ridge Parkway.
- Fleet type (e.g., ports, airports, marine, school buses);
Hybrid bucket truck and Light fleet vehicles – Cars, Pickups, SUVs
- Mitigation action (e.g., engine repower, vehicle replacement, deployment of LD ZEV supply equipment/Shorepower systems);
Deployment of ZEV charging infrastructure to encourage EV adoption in Blue Ridge service territory
- Number of engines/vehicles/vessels/equipment targeted for emission reductions;
Targeting 200 ZEV purchases per year in Blue Ridge Energy service territory
- Emission reduction/offset technology to be used:
50 Level 2 Commercial EV Chargers (\$250,000)
3 Level 3 DC Fast Chargers (\$100,000)
Hybrid bucket truck (\$200,000)
- Estimated cost of project:
\$550,000
- A description of the expected overall benefits of the proposed mitigation activity, including a description of how the proposed project mitigates the impacts of nitrogen oxides (NO_x) emissions.
According to the US Department of Energy’s Alternative Fuels Data Center, based on state averages for generation mix in NC, an all-electric vehicle will produce 7242 pounds fewer CO₂ equivalents than a gasoline powered vehicle.

If Blue Ridge Energy achieved target goal of 200 new EV purchases per year, that would result in the avoidance of 1.45 million pounds of CO2 emissions annually.

https://www.afdc.energy.gov/vehicles/electric_emissions.php

Project Detail:

- Provide information on specific engines/vehicles/vessels/equipment targeted for emission reductions, including (where applicable):
 - Number of vehicles, class or equipment type
1 hybrid electric bucket truck (Class 5: 16,001-19,500 lbs.)
 - engine make, engine model, engine model year, current tier level or emission standards
 - fuel type, amount of fuel used, annual miles travelled or annual usage rate, annual idling hours
**Diesel, expected idling fuel usage reduction:
6 gallons per day
260 working days per year
Expected carbon offset 12 metric tons/yr.**
<http://www.utilityproducts.com/articles/print/volume-5/issue-12/product-focus/vehicles-accessories/hybrid-bucket-trucks-gaining-traction133.html>

- Provide information on LD ZEV supply equipment (electric or hydrogen)
 - Number:
**50 Level 2 Commercial EV Chargers
3 Level 3 DC Fast Chargers**
 - Location:
**Level 2 Charging stations to be deployed in downtown areas throughout Blue Ridge service territory adjacent to shopping, restaurants, movie theaters and parks.
Level 3 Charging stations to be installed at Blue Ridge Energy district offices along major 321, 421 transportation corridors & Blue Ridge Parkway (Boone, Blowing Rock, Sparta)**

- How should determination be made on whether a proposed project will benefit areas that have been disproportionately impacted by emissions of nitrogen oxides (NOx) or other pollutants?
Blue Ridge believes this standard will penalize rural, less populated areas that are currently underserved by ZEV infrastructure by favoring urban areas that already have higher rates of EV ownership and charging infrastructure. It is vital that all areas receive significant investment in the electrification of

transportation. Proposed projects along major transportation corridors should be weighted favorably since ensuring the ability to travel longer distances will accelerate the transition from gasoline powered vehicles.

- Whether a project applicant is low income, minority, or disadvantaged or operates vehicles in these communities.

Weighting project applicants by the average household income would be a fair way to ensure that rural communities receive a fair portion of trust funding

- Benefits to areas that have been disproportionately impacted by NO_x and other pollutants.

Based upon the NC Emission Mapping Tool 2010, Blue Ridge Energy's service territory has a high level of NO_x producing facilities per capita due to a high concentration of furniture manufacturing facilities

<https://deq.nc.gov/about/divisions/air-quality/air-quality-data/nc-emissions-mapping-tool-2010>

Capital and Project Costs:

- Calculate and provide projected capital cost (\$/unit) and total project cost. Note calculations for proposed LD ZEV projects should include operation and maintenances cost, and calculations for eligible all-electric mitigation actions should include charging infrastructure cost (where applicable); and
- Identify projected cost share and, if applicable, what additional sources of funds may be utilized as matching funds.

Expected Proposed Project Benefits:

- Calculate and provide the expected annual and lifetime project emissions reductions/offsets for NO_x.
- Calculate and provide capital cost effectiveness (\$/short ton of NO_x reduced for each unit) and total cost effectiveness (\$/short ton of NO_x reduced for the entire project). **Utilizing the Greet fleet footprint calculator, the replacement of a standard bucket truck with a hybrid version would yield a savings of 22 short tons of GHG per year. At an estimated cost of \$200,000, the cost effectiveness of this project would be approximately \$9090/short ton of NO_x**

Software tools available to calculate projected emissions reductions and capital and total cost effectiveness of proposed mitigation projects:

- Environmental Protection Agency’s (EPA) Diesel Emissions Quantifier Tool: <https://www.epa.gov/cleandiesel/diesel-emissions-quantifier-deq>
- Argonne National Laboratory Alternative Fuel Life-Cycle Environmental and Economic Transportation (AFLEET) Tool (2016 rev1): <https://greet.es.anl.gov/afleet>
- Greenhouse gases, Regulated Emissions, and Energy use in Transportation Model (GREET 2012): https://greet.es.anl.gov/carbon_footprint_calculator

Identify the method(s) used to calculate the emissions reductions/offsets and cost, and describe and document your methods.

3. ADDITIONAL INFORMATION

Confidentiality of Information:

DEQ recommends not including any confidential business information (CBI) in your responses. However, if CBI is included, understand that ownership of all data, materials, and documentation submitted will be subject to public inspection in accordance with the North Carolina Public Records Law (N.C. G.S § 132.6).

RFI Questions:

All questions concerning this RFI should be directed to Phyllis Jones or Brian Phillips via email, daq.NC_VWGrants@ncdenr.gov. **The subject line of your e-mail should read: “Questions on NC VW RFI”.**

RFI Responses:

DEQ appreciates your participation and responses to this RFI. Please strive to limit responses to no more than 15 pages in length.

Submit your response via email as a Word or PDF attachment to daq.NC_VWGrants@ncdenr.gov or via mail to the following address:

**NC VW Settlement RFI
Division of Air Quality – Mobile Sources
217 WEST JONES STREET
1641 MAIL SERVICE CENTER RALEIGH
NC 27699-1641.**

It is recommended that email attachments with file sizes exceeding 10MB be compressed (i.e., zipped) to ensure message delivery. The subject line of the e-mail containing your response to this RFI should read: "**Response to NC VW RFI**".

Responses must be received or postmarked by **December 31, 2017**.

Public Posting of RFI:

This RFI will be posted on the following location:

- North Carolina Department of Environmental Quality website (Website URL)

Air Quality and Economic Benefits of Electric Transportation

Plug-In NC recommendations for Volkswagen environmental mitigation funds:

- Allocate the maximum 15 percent of the funds to increasing electric vehicle charging infrastructure in North Carolina.
- Accelerate the proven benefits of light-duty electric vehicle adoption by immediately expanding EV charging networks into low coverage/high impact areas.
- Prioritize medium and heavy duty vehicle replacements with available electric vehicles.

Why support electric vehicles?



Environmental Improvements

- Air quality improvements are the goal of the Volkswagen Settlement funds.
- Investing in charging infrastructure can help move the consumer marketplace to electric vehicles for a big impact on NOx emissions.
- The electric grid gets cleaner every day and emissions benefits will grow over time.



Economic Development

- Several NC companies work with electric vehicles, including charging station manufacturers and grid integration suppliers. These include ABB, General Electric, Siemens and Brightfield Transportation Solutions.
- By shifting to electric fuel, drivers save money and spend locally.



Cost Savings

- Electricity is a \$1 per gallon equivalent fuel-alternative.
- Federal tax credits and dealer incentives make electric vehicle purchases attractive.
- Electric vehicles have lower maintenance costs.



Energy Independence

- Electric fuels are locally generated.
- Domestically produced fuels are not as subject to international influences and/or severe weather events.
- A variable mix of electric generation fuels provides stability in electricity pricing.



Beneficial Grid Asset

- Encourage greater integration of renewable generation, help manage peak loads, optimize energy efficiency and enable vehicle-to-grid power supply.

EV Growth

NC growth in light-duty electric vehicles:
50% year over year

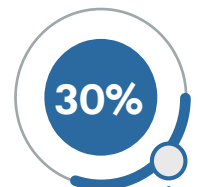

Public charging station growth:
30% over the last year

Still need more...

- NC has a good charging network, however there are still a lot of gaps!
- The Electric Power Research Institute (EPRI) recommends one public charging station for every four vehicles.

Value Proposition

Charging Infrastructure Investment

Charging Infrastructure is Easy to Install.

- Electric supply infrastructure is already in place
- No underground storage tank or hazardous material permits, etc.

This is a Turning-Point Opportunity!

- New technology adoption curve is exponential
- Consumer confidence has compounding effect

Other Benefits

TOURISM destinations can attract more visitors. Electric vehicles can charge while visiting attractions across the state, including rural destination areas.

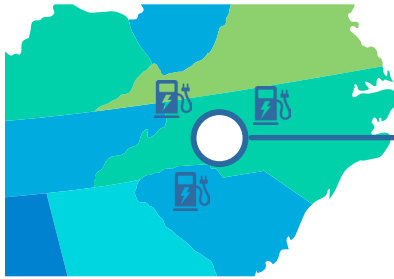

Visitors from other states will stop in NC to charge while traveling.

NC will be seen as a state that promotes green tourism.



MEDIUM and HEAVY DUTY electric vehicles
What is available?



Reduced emissions even with plug-in hybrids!

There are more emissions reductions per mile for medium and heavy-duty vehicles due to the low per gallon mileage.

What is Plug-In NC?

plug-in nc

- State wide collaborative industry group promoting electric vehicle adoption since 2011.
- Long time planning partner with the Department of Energy and North Carolina's Clean Cities Coalitions.
- Promote electric vehicle adoptions through education and outreach, consulting and resource development.
- Provides a collaborative opportunity for stakeholders to work together to ensure a seamless integration of plug-in electric vehicles into our local communities.

Class	Type	Example Manufacturers
Class 4	Hybrid-Electric Ford Transit Van	XL Hybrids
Class 5	Hybrid-Electric Box Truck	HINO
Class 6	All-Electric Refuse Truck	BYD
Class 7	Kalmar All-Electric T2 Yard Tractor	TransPower
Class 8	All-Electric Class 8 Tractor	US Hybrid
Forklifts	All-Electric Lithium Ion BYD Forklift	BYD
Transit Buses	All-Electric Transit Bus (35 or 40 foot)	Proterra
School Buses	All-Electric School Bus	Blue Bird

How to Connect:

(919) 857-9000

pluginnc@advancedenergy.org

pluginnc.com



Plug-In NC Member Organizations

- Advanced Energy
- Aerie Bed and Breakfast
- Asheville Outlets
- Bernhardt Furniture Company
- Black Bear Solar Institute
- Blue Ridge Energy
- Blue Ridge EV Club
- Brentwood Solar House
- Brightfield Transportation Solutions
- Brunswick Electric Membership Corporation
- Campbell University
- Canyons of the Blue Ridge
- Centralina Council of Governments
- Centralina Clean Fuels Coalition
- ChargePoint
- Cisco
- City of Asheville
- City of Charlotte
- City of Hendersonville
- City of Winston-Salem
- Correll Associates
- Country Inn & Suites
- Courtyard Raleigh Crabtree
- Double Tree Rocky Mount
- Duke Energy
- Durham County Government
- Earth Shine Nature Programs
- Eastern Carolina Council of Governments
- Economy Inn Greenville
- Elon University
- EVgo
- Front Street Village
- General Electric
- Hanna House
- Hybrid Shop of the Carolinas
- Land of Sky Clean Vehicles Coalition
- Land of Sky Regional Council
- Lord Corporation
- Mayfaire Town Center
- Mills-Rentals
- NC Clean Energy Technology Center
- NC Electric Membership Corporation
- North Carolina State University
- Orange County
- Pecan Tree Inn Bed and Breakfast
- Piedmont EMC
- Piedmont Triad International Airport
- Piedmont Triad Regional Council
- Randolph Electric Membership Corporation
- Southern Alliance for Clean Energy
- Stanhope Apartments
- Tanger Outlets Mebane
- The Inn on Pamlico Sound
- The Mayton Inn
- Town of Black Mountain
- Town of Cary
- Town of Chapel Hill
- Town of Edenton
- Town of Montreat
- Town of Morrisville
- Town-Chapel-Hill
- Triangle Clean Cities Coalition
- Triangle J Council of Governments
- UNC Asheville
- UNC Chapel Hill
- UNC Charlotte
- UNC Pembroke
- Western Carolina University
- Wildhorse Adventures

How to Connect:

(919) 857-9000

pluginnc@advancedenergy.org

pluginnc.com



From: Willard Bucklen (bill@bucklen.com) Sent You a Personal Message
To: daq.NC_VWGrants
Subject: [External] Use Volkswagen funds to electrify NC transportation
Date: Sunday, December 31, 2017 4:42:57 PM

CAUTION: External email. Do not click links or open attachments unless verified. Send all suspicious email as an attachment to report.spam@nc.gov.

Dear Division of Air Quality,

I am writing to urge DEQ to wisely invest the \$92 million in Volkswagen settlement funds in electric vehicles and infrastructure. Taking advantage of these funds to jumpstart the electrification of North Carolina's transportation sector will mean less money sent out of state for petroleum, more in-state jobs, and cleaner air.

Specifically, I recommend that DEQ allocate the maximum allowable amount (15%) of the funds for electric vehicle charging infrastructure and installations. And I encourage DEQ to prioritize electric vehicles and buses for replacement whenever possible with the other 85% of the settlement funds. Doing so will maximize the local economic impact and the reduction of air pollution.

I encourage you to not use the funding for natural gas, propane or diesel vehicles. Further dependence on fossil fuels means more pollution. Only a transition to electric vehicles and investment in EV infrastructure will put us on the road to a 100% clean transportation sector in North Carolina.

Sincerely,

Willard Bucklen
3607 Timberoak Drive
Greensboro, NC 27410
bill@bucklen.com
(336) 288-2777

This message was sent by KnowWho, as a service provider only, on behalf of the individual noted in the sender information.

From: Jeffrey DeCristofaro (jeffreydecristofaro@gmail.com) Sent You a Personal Message
To: [daq.NC_VWGrants](#)
Subject: [External] Use Volkswagen funds to electrify NC transportation
Date: Sunday, December 31, 2017 1:26:47 AM

CAUTION: External email. Do not click links or open attachments unless verified. Send all suspicious email as an attachment to report.spam@nc.gov.

Dear Division of Air Quality,

I am writing to urge DEQ to wisely invest the \$92 million in Volkswagen settlement funds in electric vehicles and infrastructure. Taking advantage of these funds to jumpstart the electrification of North Carolina's transportation sector will mean less money sent out of state for petroleum, more in-state jobs, and cleaner air.

Specifically, I recommend that DEQ allocate the maximum allowable amount (15%) of the funds for electric vehicle charging infrastructure and installations. And I encourage DEQ to prioritize electric vehicles and buses for replacement whenever possible with the other 85% of the settlement funds. Doing so will maximize the local economic impact and the reduction of air pollution.

I encourage you to not use the funding for natural gas, propane or diesel vehicles. Further dependence on fossil fuels means more pollution. Only a transition to electric vehicles and investment in EV infrastructure will put us on the road to a 100% clean transportation sector in North Carolina.

Sincerely,

Jeffrey DeCristofaro
37 Lee Ave.
Asheville, NC 28804
jeffreydecristofaro@gmail.com
(828) 545-5968

This message was sent by KnowWho, as a service provider only, on behalf of the individual noted in the sender information.

From: Donna Ohmstead (dohmstead@nctv.com) Sent You a Personal Message
To: [daq.NC_VWGrants](#)
Subject: [External] Use Volkswagen funds to electrify NC transportation
Date: Saturday, December 30, 2017 11:18:04 PM

CAUTION: External email. Do not click links or open attachments unless verified. Send all suspicious email as an attachment to report.spam@nc.gov.

Dear Division of Air Quality,

I am writing to urge DEQ to wisely invest the \$92 million in Volkswagen settlement funds in electric vehicles and infrastructure. Taking advantage of these funds to jumpstart the electrification of North Carolina's transportation sector will mean less money sent out of state for petroleum, more in-state jobs, and cleaner air.

Specifically, I recommend that DEQ allocate the maximum allowable amount (15%) of the funds for electric vehicle charging infrastructure and installations. And I encourage DEQ to prioritize electric vehicles and buses for replacement whenever possible with the other 85% of the settlement funds. Doing so will maximize the local economic impact and the reduction of air pollution.

I encourage you to not use the funding for natural gas, propane or diesel vehicles. Further dependence on fossil fuels means more pollution. Only a transition to electric vehicles and investment in EV infrastructure will put us on the road to a 100% clean transportation sector in North Carolina.

Sincerely,

Donna Ohmstead
151 Carolina Ave
Forest City, NC 28043
dohmstead@nctv.com
(828) 245-8867

This message was sent by KnowWho, as a service provider only, on behalf of the individual noted in the sender information.

From: Alan Parry (parrya31@gmail.com) Sent You a Personal Message
To: daq.NC_VWGrants
Subject: [External] Use Volkswagen funds to electrify NC transportation
Date: Saturday, December 30, 2017 4:07:56 PM

CAUTION: External email. Do not click links or open attachments unless verified. Send all suspicious email as an attachment to report.spam@nc.gov.

Dear Division of Air Quality,

I am writing to urge DEQ to wisely invest the \$92 million in Volkswagen settlement funds in electric vehicles and infrastructure. Taking advantage of these funds to jumpstart the electrification of North Carolina's transportation sector will mean less money sent out of state for petroleum, more in-state jobs, and cleaner air.

Specifically, I recommend that DEQ allocate the maximum allowable amount (15%) of the funds for electric vehicle charging infrastructure and installations. And I encourage DEQ to prioritize electric vehicles and buses for replacement whenever possible with the other 85% of the settlement funds. Doing so will maximize the local economic impact and the reduction of air pollution.

I encourage you to not use the funding for natural gas, propane or diesel vehicles. Further dependence on fossil fuels means more pollution. Only a transition to electric vehicles and investment in EV infrastructure will put us on the road to a 100% clean transportation sector in North Carolina.

Sincerely,

Alan Parry
210 Oxford Hills Dr
Chapel Hill, NC 27514
parrya31@gmail.com
(919) 523-7521

This message was sent by KnowWho, as a service provider only, on behalf of the individual noted in the sender information.

From: Zoe Yost (fastfinch3@gmail.com) Sent You a Personal Message
To: [daq.NC_VWGrants](#)
Subject: [External] Use Volkswagen funds to electrify NC transportation
Date: Saturday, December 30, 2017 12:14:32 PM

CAUTION: External email. Do not click links or open attachments unless verified. Send all suspicious email as an attachment to report.spam@nc.gov.

Dear Division of Air Quality,

I am writing to urge DEQ to wisely invest the \$92 million in Volkswagen settlement funds in electric vehicles and infrastructure. Taking advantage of these funds to jumpstart the electrification of North Carolina's transportation sector will mean less money sent out of state for petroleum, more in-state jobs, and cleaner air.

Specifically, I recommend that DEQ allocate the maximum allowable amount (15%) of the funds for electric vehicle charging infrastructure and installations. And I encourage DEQ to prioritize electric vehicles and buses for replacement whenever possible with the other 85% of the settlement funds. Doing so will maximize the local economic impact and the reduction of air pollution.

I encourage you to not use the funding for natural gas, propane or diesel vehicles. Further dependence on fossil fuels means more pollution. Only a transition to electric vehicles and investment in EV infrastructure will put us on the road to a 100% clean transportation sector in North Carolina.

Sincerely,

Zoe Yost
119 Sun Ct
Newark, DE 19711
fastfinch3@gmail.com
(302) 234-1099

This message was sent by KnowWho, as a service provider only, on behalf of the individual noted in the sender information.

From: Aleece Mann (aleecemann@hotmail.com) Sent You a Personal Message
To: [daq.NC_VWGrants](#)
Subject: [External] Use Volkswagen funds to electrify NC transportation
Date: Saturday, December 30, 2017 11:23:35 AM

CAUTION: External email. Do not click links or open attachments unless verified. Send all suspicious email as an attachment to report.spam@nc.gov.

Dear Division of Air Quality,

I am writing to urge DEQ to wisely invest the \$92 million in Volkswagen settlement funds in electric vehicles and infrastructure. Taking advantage of these funds to jumpstart the electrification of North Carolina's transportation sector will mean less money sent out of state for petroleum, more in-state jobs, and cleaner air.

Specifically, I recommend that DEQ allocate the maximum allowable amount (15%) of the funds for electric vehicle charging infrastructure and installations. And I encourage DEQ to prioritize electric vehicles and buses for replacement whenever possible with the other 85% of the settlement funds. Doing so will maximize the local economic impact and the reduction of air pollution.

I encourage you to not use the funding for natural gas, propane or diesel vehicles. Further dependence on fossil fuels means more pollution. Only a transition to electric vehicles and investment in EV infrastructure will put us on the road to a 100% clean transportation sector in North Carolina.

Sincerely,

Aleece Mann
18367 Rodeo Trail
Norman, OK 73072
aleecemann@hotmail.com
(405) 620-4363

This message was sent by KnowWho, as a service provider only, on behalf of the individual noted in the sender information.

From: Janet Hood (janet@jandjhood.com) Sent You a Personal Message
To: [daq.NC_VWGrants](#)
Subject: [External] Use Volkswagen funds to electrify NC transportation
Date: Friday, December 29, 2017 3:27:41 PM

CAUTION: External email. Do not click links or open attachments unless verified. Send all suspicious email as an attachment to report.spam@nc.gov.

Dear Division of Air Quality,

I am writing to urge DEQ to wisely invest the \$92 million in Volkswagen settlement funds in electric vehicles and infrastructure. Taking advantage of these funds to jumpstart the electrification of North Carolina's transportation sector will mean less money sent out of state for petroleum, more in-state jobs, and cleaner air.

Specifically, I recommend that DEQ allocate the maximum allowable amount (15%) of the funds for electric vehicle charging infrastructure and installations. And I encourage DEQ to prioritize electric vehicles and buses for replacement whenever possible with the other 85% of the settlement funds. Doing so will maximize the local economic impact and the reduction of air pollution.

I encourage you to not use the funding for natural gas, propane or diesel vehicles. Further dependence on fossil fuels means more pollution. Only a transition to electric vehicles and investment in EV infrastructure will put us on the road to a 100% clean transportation sector in North Carolina.

Sincerely,

Janet Hood
210 Sunnyside Dr.
Washington, NC 27889
janet@jandjhood.com
(281) 536-7782

This message was sent by KnowWho, as a service provider only, on behalf of the individual noted in the sender information.

From: Bob Cherry (bcherry001@gmail.com) Sent You a Personal Message
To: [daq.NC_VWGrants](#)
Subject: [External] Support electified NC transportation with VW money
Date: Friday, December 29, 2017 12:31:15 PM

CAUTION: External email. Do not click links or open attachments unless verified. Send all suspicious email as an attachment to report.spam@nc.gov.

Dear Division of Air Quality,

I am writing to urge DEQ to wisely invest the \$92 million in Volkswagen settlement funds in electric vehicles and infrastructure. Taking advantage of these funds to jumpstart the electrification of North Carolina's transportation sector will mean less money sent out of state for petroleum, more in-state jobs, and cleaner air.

Specifically, I recommend that DEQ allocate the maximum allowable amount (15%) of the funds for electric vehicle charging infrastructure and installations. And I encourage DEQ to prioritize electric vehicles and buses for replacement whenever possible with the other 85% of the settlement funds. Doing so will maximize the local economic impact and the reduction of air pollution.

I encourage you to not use the funding for natural gas, propane or diesel vehicles. Further dependence on fossil fuels means more pollution. Only a transition to electric vehicles and investment in EV infrastructure will put us on the road to a 100% clean transportation sector in North Carolina.

Sincerely,

Bob Cherry
301 Perkins St.
Boone, NC 28607
bcherry001@gmail.com
(828) 265-2829

This message was sent by KnowWho, as a service provider only, on behalf of the individual noted in the sender information.

From: Mary Frazer (frazem4@hotmail.com) Sent You a Personal Message
To: [daq.NC_VWGrants](#)
Subject: [External] Use Volkswagen funds to electrify NC transportation
Date: Wednesday, December 27, 2017 7:56:28 PM

CAUTION: External email. Do not click links or open attachments unless verified. Send all suspicious email as an attachment to report.spam@nc.gov.

Dear Division of Air Quality,

I am writing to urge DEQ to wisely invest the \$92 million in Volkswagen settlement funds in electric vehicles and infrastructure. Taking advantage of these funds to jumpstart the electrification of North Carolina's transportation sector will mean less money sent out of state for petroleum, more in-state jobs, and cleaner air.

Specifically, I recommend that DEQ allocate the maximum allowable amount (15%) of the funds for electric vehicle charging infrastructure and installations. And I encourage DEQ to prioritize electric vehicles and buses for replacement whenever possible with the other 85% of the settlement funds. Doing so will maximize the local economic impact and the reduction of air pollution.

I encourage you to not use the funding for natural gas, propane or diesel vehicles. Further dependence on fossil fuels means more pollution. Only a transition to electric vehicles and investment in EV infrastructure will put us on the road to a 100% clean transportation sector in North Carolina.

Sincerely,

Mary Frazer
1716 Evergreen
Raleigh, NC 27603
frazem4@hotmail.com
(919) 829-4210

This message was sent by KnowWho, as a service provider only, on behalf of the individual noted in the sender information.

From: Nicole Ditillo (n.m.ditillo@gmail.com) Sent You a Personal Message
To: [daq.NC_VWGrants](#)
Subject: [External] Use Volkswagen funds to electrify NC transportation
Date: Tuesday, December 26, 2017 7:38:39 PM

CAUTION: External email. Do not click links or open attachments unless verified. Send all suspicious email as an attachment to report.spam@nc.gov.

Dear Division of Air Quality,

I am writing to urge DEQ to wisely invest the \$92 million in Volkswagen settlement funds in electric vehicles and infrastructure. Taking advantage of these funds to jumpstart the electrification of North Carolina's transportation sector will mean less money sent out of state for petroleum, more in-state jobs, and cleaner air.

Specifically, I recommend that DEQ allocate the maximum allowable amount (15%) of the funds for electric vehicle charging infrastructure and installations. And I encourage DEQ to prioritize electric vehicles and buses for replacement whenever possible with the other 85% of the settlement funds. Doing so will maximize the local economic impact and the reduction of air pollution.

I encourage you to not use the funding for natural gas, propane or diesel vehicles. Further dependence on fossil fuels means more pollution. Only a transition to electric vehicles and investment in EV infrastructure will put us on the road to a 100% clean transportation sector in North Carolina.

Sincerely,

Nicole Ditillo
1012 Village Greenway Apt C
Cary, NC 27511
n.m.ditillo@gmail.com
(410) 207-2546

This message was sent by KnowWho, as a service provider only, on behalf of the individual noted in the sender information.

From: Kelly Horn (kfhorn@bellsouth.net) Sent You a Personal Message
To: [daq.NC_VWGrants](#)
Subject: [External] Use Volkswagen funds to electrify NC transportation
Date: Tuesday, December 26, 2017 12:35:03 PM

CAUTION: External email. Do not click links or open attachments unless verified. Send all suspicious email as an attachment to report.spam@nc.gov.

Dear Division of Air Quality,

I am writing to urge DEQ to wisely invest the \$92 million in Volkswagen settlement funds in electric vehicles and infrastructure. Taking advantage of these funds to jumpstart the electrification of North Carolina's transportation sector will mean less money sent out of state for petroleum, more in-state jobs, and cleaner air.

Specifically, I recommend that DEQ allocate the maximum allowable amount (15%) of the funds for electric vehicle charging infrastructure and installations. And I encourage DEQ to prioritize electric vehicles and buses for replacement whenever possible with the other 85% of the settlement funds. Doing so will maximize the local economic impact and the reduction of air pollution.

I encourage you to not use the funding for natural gas, propane or diesel vehicles. Further dependence on fossil fuels means more pollution. Only a transition to electric vehicles and investment in EV infrastructure will put us on the road to a 100% clean transportation sector in North Carolina.

Sincerely,

Kelly Horn
1505 Caswell Street
Raleigh, NC 27608
kfhorn@bellsouth.net
(919) 618-6385

This message was sent by KnowWho, as a service provider only, on behalf of the individual noted in the sender information.

From: Shane Slabaugh (slayball2237@mail.com) Sent You a Personal Message
To: [daq.NC_VWGrants](#)
Subject: [External] Use Volkswagen funds to electrify NC transportation
Date: Tuesday, December 26, 2017 11:37:54 AM

CAUTION: External email. Do not click links or open attachments unless verified. Send all suspicious email as an attachment to report.spam@nc.gov.

Dear Division of Air Quality,

I am writing to urge DEQ to wisely invest the \$92 million in Volkswagen settlement funds in electric vehicles and infrastructure. Taking advantage of these funds to jumpstart the electrification of North Carolina's transportation sector will mean less money sent out of state for petroleum, more in-state jobs, and cleaner air.

Specifically, I recommend that DEQ allocate the maximum allowable amount (15%) of the funds for electric vehicle charging infrastructure and installations. And I encourage DEQ to prioritize electric vehicles and buses for replacement whenever possible with the other 85% of the settlement funds. Doing so will maximize the local economic impact and the reduction of air pollution.

I encourage you to not use the funding for natural gas, propane or diesel vehicles. Further dependence on fossil fuels means more pollution. Only a transition to electric vehicles and investment in EV infrastructure will put us on the road to a 100% clean transportation sector in North Carolina.

Sincerely,

Shane Slabaugh
332 Shady Grove Ln
Winston-Salem, NC 27107
slayball2237@mail.com
(336) 978-3487

This message was sent by KnowWho, as a service provider only, on behalf of the individual noted in the sender information.

From: Joan Melton (meltonfour@embarqmail.com) Sent You a Personal Message
To: [daq.NC_VWGrants](#)
Subject: [External] Use Volkswagen funds to electrify NC transportation
Date: Tuesday, December 26, 2017 11:00:41 AM

CAUTION: External email. Do not click links or open attachments unless verified. Send all suspicious email as an attachment to report.spam@nc.gov.

Dear Division of Air Quality,

I am writing to urge DEQ to wisely invest the \$92 million in Volkswagen settlement funds in electric vehicles and infrastructure. Taking advantage of these funds to jumpstart the electrification of North Carolina's transportation sector will mean less money sent out of state for petroleum, more in-state jobs, and cleaner air.

Specifically, I recommend that DEQ allocate the maximum allowable amount (15%) of the funds for electric vehicle charging infrastructure and installations. And I encourage DEQ to prioritize electric vehicles and buses for replacement whenever possible with the other 85% of the settlement funds. Doing so will maximize the local economic impact and the reduction of air pollution.

I encourage you to not use the funding for natural gas, propane or diesel vehicles. Further dependence on fossil fuels means more pollution. Only a transition to electric vehicles and investment in EV infrastructure will put us on the road to a 100% clean transportation sector in North Carolina.

Sincerely,

Joan Melton
6700 Butler Nursery Rd
Fayetteville, NC 28306
meltonfour@embarqmail.com
(910) 485-6348

This message was sent by KnowWho, as a service provider only, on behalf of the individual noted in the sender information.

From: Vivian Lord (vlord02@gmail.com) Sent You a Personal Message
To: [daq.NC_VWGrants](#)
Subject: [External] Use Volkswagen funds to electrify NC transportation
Date: Sunday, December 24, 2017 1:16:11 PM

CAUTION: External email. Do not click links or open attachments unless verified. Send all suspicious email as an attachment to report.spam@nc.gov.

Dear Division of Air Quality,

I am writing to urge DEQ to wisely invest the \$92 million in Volkswagen settlement funds in electric vehicles and infrastructure. Taking advantage of these funds to jumpstart the electrification of North Carolina's transportation sector will mean less money sent out of state for petroleum, more in-state jobs, and cleaner air.

Specifically, I recommend that DEQ allocate the maximum allowable amount (15%) of the funds for electric vehicle charging infrastructure and installations. And I encourage DEQ to prioritize electric vehicles and buses for replacement whenever possible with the other 85% of the settlement funds. Doing so will maximize the local economic impact and the reduction of air pollution.

I encourage you to not use the funding for natural gas, propane or diesel vehicles. Further dependence on fossil fuels means more pollution. Only a transition to electric vehicles and investment in EV infrastructure will put us on the road to a 100% clean transportation sector in North Carolina.

Sincerely,

Vivian Lord
8335 McCarron way
Charlotte, NC 28215
vlord02@gmail.com
(704) 796-0539

This message was sent by KnowWho, as a service provider only, on behalf of the individual noted in the sender information.

From: Dave Lewis (dave@lewis5.com) Sent You a Personal Message
To: daq.NC_VWGrants
Subject: [External] Use Volkswagen funds to electrify NC transportation
Date: Sunday, December 24, 2017 9:28:48 AM

CAUTION: External email. Do not click links or open attachments unless verified. Send all suspicious email as an attachment to report.spam@nc.gov.

Dear Division of Air Quality,

I am writing to urge DEQ to wisely invest the \$92 million in Volkswagen settlement funds in electric vehicles and infrastructure. Taking advantage of these funds to jumpstart the electrification of North Carolina's transportation sector will mean less money sent out of state for petroleum, more in-state jobs, and cleaner air.

Specifically, I recommend that DEQ allocate the maximum allowable amount (15%) of the funds for electric vehicle charging infrastructure and installations. And I encourage DEQ to prioritize electric vehicles and buses for replacement whenever possible with the other 85% of the settlement funds. Doing so will maximize the local economic impact and the reduction of air pollution.

I encourage you to not use the funding for natural gas, propane or diesel vehicles. Further dependence on fossil fuels means more pollution. Only a transition to electric vehicles and investment in EV infrastructure will put us on the road to a 100% clean transportation sector in North Carolina.

Sincerely,

Dave Lewis
190 Broadway St
Asheville, NC 28801
dave@lewis5.com
(828) 424-5242

This message was sent by KnowWho, as a service provider only, on behalf of the individual noted in the sender information.

From: Natalie Belanga (natbelanga@gmail.com) Sent You a Personal Message
To: [daq.NC_VWGrants](#)
Subject: [External] Use Volkswagen funds to electrify NC transportation
Date: Sunday, December 24, 2017 8:39:22 AM

CAUTION: External email. Do not click links or open attachments unless verified. Send all suspicious email as an attachment to report.spam@nc.gov.

Dear Division of Air Quality,

I am writing to urge DEQ to wisely invest the \$92 million in Volkswagen settlement funds in electric vehicles and infrastructure. Taking advantage of these funds to jumpstart the electrification of North Carolina's transportation sector will mean less money sent out of state for petroleum, more in-state jobs, and cleaner air.

Specifically, I recommend that DEQ allocate the maximum allowable amount (15%) of the funds for electric vehicle charging infrastructure and installations. And I encourage DEQ to prioritize electric vehicles and buses for replacement whenever possible with the other 85% of the settlement funds. Doing so will maximize the local economic impact and the reduction of air pollution.

I encourage you to not use the funding for natural gas, propane or diesel vehicles. Further dependence on fossil fuels means more pollution. Only a transition to electric vehicles and investment in EV infrastructure will put us on the road to a 100% clean transportation sector in North Carolina.

Sincerely,

Natalie Belanga
9 Birch St.
Asheville, NC 28801
natbelanga@gmail.com
(828) 785-9580

This message was sent by KnowWho, as a service provider only, on behalf of the individual noted in the sender information.

From: Brian Reed (btreed91@gmail.com) Sent You a Personal Message
To: [daq.NC_VWGrants](#)
Subject: [External] Use Volkswagen funds to electrify NC transportation
Date: Saturday, December 23, 2017 2:17:46 PM

CAUTION: External email. Do not click links or open attachments unless verified. Send all suspicious email as an attachment to report.spam@nc.gov.

Dear Division of Air Quality,

I am writing to urge DEQ to wisely invest the \$92 million in Volkswagen settlement funds in electric vehicles and infrastructure. Taking advantage of these funds to jumpstart the electrification of North Carolina's transportation sector will mean less money sent out of state for petroleum, more in-state jobs, and cleaner air.

Specifically, I recommend that DEQ allocate the maximum allowable amount (15%) of the funds for electric vehicle charging infrastructure and installations. And I encourage DEQ to prioritize electric vehicles and buses for replacement whenever possible with the other 85% of the settlement funds. Doing so will maximize the local economic impact and the reduction of air pollution.

I encourage you to not use the funding for natural gas, propane or diesel vehicles. Further dependence on fossil fuels means more pollution. Only a transition to electric vehicles and investment in EV infrastructure will put us on the road to a 100% clean transportation sector in North Carolina.

Sincerely,

Brian Reed
2025 Lakebay Rd
Vass, NC 28394
btreed91@gmail.com
(404) 661-2241

This message was sent by KnowWho, as a service provider only, on behalf of the individual noted in the sender information.

From: Lori Bright (britespirit1@yahoo.com) Sent You a Personal Message
To: [daq.NC_VWGrants](#)
Subject: [External] Use Volkswagen funds to electrify NC transportation
Date: Saturday, December 23, 2017 9:05:26 AM

CAUTION: External email. Do not click links or open attachments unless verified. Send all suspicious email as an attachment to report.spam@nc.gov.

Dear Division of Air Quality,

I am writing to urge DEQ to wisely invest the \$92 million in Volkswagen settlement funds in electric vehicles and infrastructure. Taking advantage of these funds to jumpstart the electrification of North Carolina's transportation sector will mean less money sent out of state for petroleum, more in-state jobs, and cleaner air.

Specifically, I recommend that DEQ allocate the maximum allowable amount (15%) of the funds for electric vehicle charging infrastructure and installations. And I encourage DEQ to prioritize electric vehicles and buses for replacement whenever possible with the other 85% of the settlement funds. Doing so will maximize the local economic impact and the reduction of air pollution.

I encourage you to not use the funding for natural gas, propane or diesel vehicles. Further dependence on fossil fuels means more pollution. Only a transition to electric vehicles and investment in EV infrastructure will put us on the road to a 100% clean transportation sector in North Carolina.

Sincerely,

Lori Bright
75 Hickory Tree Rd
Asheville, NC 28805
britespirit1@yahoo.com
(828) 699-7924

This message was sent by KnowWho, as a service provider only, on behalf of the individual noted in the sender information.

From: Shannon Gentry (senoni.rae@gmail.com) Sent You a Personal Message
To: [daq.NC_VWGrants](#)
Subject: [External] Use Volkswagen funds to electrify NC transportation
Date: Saturday, December 23, 2017 8:46:33 AM

CAUTION: External email. Do not click links or open attachments unless verified. Send all suspicious email as an attachment to report.spam@nc.gov.

Dear Division of Air Quality,

I am writing to urge DEQ to wisely invest the \$92 million in Volkswagen settlement funds in electric vehicles and infrastructure. Taking advantage of these funds to jumpstart the electrification of North Carolina's transportation sector will mean less money sent out of state for petroleum, more in-state jobs, and cleaner air.

Specifically, I recommend that DEQ allocate the maximum allowable amount (15%) of the funds for electric vehicle charging infrastructure and installations. And I encourage DEQ to prioritize electric vehicles and buses for replacement whenever possible with the other 85% of the settlement funds. Doing so will maximize the local economic impact and the reduction of air pollution.

I encourage you to not use the funding for natural gas, propane or diesel vehicles. Further dependence on fossil fuels means more pollution. Only a transition to electric vehicles and investment in EV infrastructure will put us on the road to a 100% clean transportation sector in North Carolina.

Sincerely,

Shannon Gentry
2208 Klein Road
Wilmington, NC 28405
senoni.rae@gmail.com
(910) 795-6775

This message was sent by KnowWho, as a service provider only, on behalf of the individual noted in the sender information.

From: Wayne Leechford (wayneleechford@gmail.com) Sent You a Personal Message
To: [daq.NC_VWGrants](#)
Subject: [External] Use Volkswagen funds to electrify NC transportation
Date: Saturday, December 23, 2017 8:27:25 AM

CAUTION: External email. Do not click links or open attachments unless verified. Send all suspicious email as an attachment to report.spam@nc.gov.

Dear Division of Air Quality,

I am writing to urge DEQ to wisely invest the \$92 million in Volkswagen settlement funds in electric vehicles and infrastructure. Taking advantage of these funds to jumpstart the electrification of North Carolina's transportation sector will mean less money sent out of state for petroleum, more in-state jobs, and cleaner air.

Specifically, I recommend that DEQ allocate the maximum allowable amount (15%) of the funds for electric vehicle charging infrastructure and installations. And I encourage DEQ to prioritize electric vehicles and buses for replacement whenever possible with the other 85% of the settlement funds. Doing so will maximize the local economic impact and the reduction of air pollution.

I encourage you to not use the funding for natural gas, propane or diesel vehicles. Further dependence on fossil fuels means more pollution. Only a transition to electric vehicles and investment in EV infrastructure will put us on the road to a 100% clean transportation sector in North Carolina.

Sincerely,

Wayne Leechford
4216 James Road
Raleigh, NC 27616
wayneleechford@gmail.com
(919) 612-4199

This message was sent by KnowWho, as a service provider only, on behalf of the individual noted in the sender information.

From: Sarah Holshouser (sjholshouser@gmail.com) Sent You a Personal Message
To: [daq.NC_VWGrants](#)
Subject: [External] Use Volkswagen funds to electrify NC transportation
Date: Friday, December 22, 2017 9:09:25 PM

CAUTION: External email. Do not click links or open attachments unless verified. Send all suspicious email as an attachment to report.spam@nc.gov.

Dear Division of Air Quality,

I am writing to urge DEQ to wisely invest the \$92 million in Volkswagen settlement funds in electric vehicles and infrastructure. Taking advantage of these funds to jumpstart the electrification of North Carolina's transportation sector will mean less money sent out of state for petroleum, more in-state jobs, and cleaner air.

Specifically, I recommend that DEQ allocate the maximum allowable amount (15%) of the funds for electric vehicle charging infrastructure and installations. And I encourage DEQ to prioritize electric vehicles and buses for replacement whenever possible with the other 85% of the settlement funds. Doing so will maximize the local economic impact and the reduction of air pollution.

I encourage you to not use the funding for natural gas, propane or diesel vehicles. Further dependence on fossil fuels means more pollution. Only a transition to electric vehicles and investment in EV infrastructure will put us on the road to a 100% clean transportation sector in North Carolina.

Sincerely,

Sarah Holshouser
821 N Bloodworth St
Raleigh, NC 27604
sjholshouser@gmail.com
(919) 531-9078

This message was sent by KnowWho, as a service provider only, on behalf of the individual noted in the sender information.

From: Lauren Hartmann (hartla15@wfu.edu) Sent You a Personal Message
To: [daq.NC_VWGrants](#)
Subject: [External] Use Volkswagen funds to electrify NC transportation
Date: Friday, December 22, 2017 5:48:09 PM

CAUTION: External email. Do not click links or open attachments unless verified. Send all suspicious email as an attachment to report.spam@nc.gov.

Dear Division of Air Quality,

I am writing to urge DEQ to wisely invest the \$92 million in Volkswagen settlement funds in electric vehicles and infrastructure. Taking advantage of these funds to jumpstart the electrification of North Carolina's transportation sector will mean less money sent out of state for petroleum, more in-state jobs, and cleaner air.

Specifically, I recommend that DEQ allocate the maximum allowable amount (15%) of the funds for electric vehicle charging infrastructure and installations. And I encourage DEQ to prioritize electric vehicles and buses for replacement whenever possible with the other 85% of the settlement funds. Doing so will maximize the local economic impact and the reduction of air pollution.

I encourage you to not use the funding for natural gas, propane or diesel vehicles. Further dependence on fossil fuels means more pollution. Only a transition to electric vehicles and investment in EV infrastructure will put us on the road to a 100% clean transportation sector in North Carolina.

Sincerely,

Lauren Hartmann
44 King Heights Dr.
Fletcher, NC 28732
hartla15@wfu.edu
(828) 989-7598

This message was sent by KnowWho, as a service provider only, on behalf of the individual noted in the sender information.

From: Louisa Sholar (lsholar@elon.edu) Sent You a Personal Message
To: [daq.NC_VWGrants](#)
Subject: [External] Use Volkswagen funds to electrify NC transportation
Date: Friday, December 22, 2017 4:22:17 PM

CAUTION: External email. Do not click links or open attachments unless verified. Send all suspicious email as an attachment to report.spam@nc.gov.

Dear Division of Air Quality,

I am writing to urge DEQ to wisely invest the \$92 million in Volkswagen settlement funds in electric vehicles and infrastructure. Taking advantage of these funds to jumpstart the electrification of North Carolina's transportation sector will mean less money sent out of state for petroleum, more in-state jobs, and cleaner air.

Specifically, I recommend that DEQ allocate the maximum allowable amount (15%) of the funds for electric vehicle charging infrastructure and installations. And I encourage DEQ to prioritize electric vehicles and buses for replacement whenever possible with the other 85% of the settlement funds. Doing so will maximize the local economic impact and the reduction of air pollution.

I encourage you to not use the funding for natural gas, propane or diesel vehicles. Further dependence on fossil fuels means more pollution. Only a transition to electric vehicles and investment in EV infrastructure will put us on the road to a 100% clean transportation sector in North Carolina.

Sincerely,

Louisa Sholar
PO BOX 1395
Mooresville, NC 28115
lsholar@elon.edu
(704) 677-8549

This message was sent by KnowWho, as a service provider only, on behalf of the individual noted in the sender information.

From: lisa fisk (lisalfisk@gmail.com) Sent You a Personal Message
To: [daq.NC_VWGrants](#)
Subject: [External] Use Volkswagen funds to electrify NC transportation
Date: Friday, December 22, 2017 3:18:13 PM

CAUTION: External email. Do not click links or open attachments unless verified. Send all suspicious email as an attachment to report.spam@nc.gov.

Dear Division of Air Quality,

I am writing to urge DEQ to wisely invest the \$92 million in Volkswagen settlement funds in electric vehicles and infrastructure. Taking advantage of these funds to jumpstart the electrification of North Carolina's transportation sector will mean less money sent out of state for petroleum, more in-state jobs, and cleaner air.

Specifically, I recommend that DEQ allocate the maximum allowable amount (15%) of the funds for electric vehicle charging infrastructure and installations. And I encourage DEQ to prioritize electric vehicles and buses for replacement whenever possible with the other 85% of the settlement funds. Doing so will maximize the local economic impact and the reduction of air pollution.

I encourage you to not use the funding for natural gas, propane or diesel vehicles. Further dependence on fossil fuels means more pollution. Only a transition to electric vehicles and investment in EV infrastructure will put us on the road to a 100% clean transportation sector in North Carolina.

Sincerely,

lisa fisk
325 Tryon St.
Burlington, NC 27217
lisalfisk@gmail.com
(336) 350-8257

This message was sent by KnowWho, as a service provider only, on behalf of the individual noted in the sender information.

From: Susan Stiles (susanbennettstiles@gmail.com) Sent You a Personal Message
To: [daq.NC_VWGrants](#)
Subject: [External] Use Volkswagen funds to electrify NC transportation
Date: Friday, December 22, 2017 6:44:08 AM

CAUTION: External email. Do not click links or open attachments unless verified. Send all suspicious email as an attachment to report.spam@nc.gov.

Dear Division of Air Quality,

I am writing to urge DEQ to wisely invest the \$92 million in Volkswagen settlement funds in electric vehicles and infrastructure. Taking advantage of these funds to jumpstart the electrification of North Carolina's transportation sector will mean less money sent out of state for petroleum, more in-state jobs, and cleaner air.

Specifically, I recommend that DEQ allocate the maximum allowable amount (15%) of the funds for electric vehicle charging infrastructure and installations. And I encourage DEQ to prioritize electric vehicles and buses for replacement whenever possible with the other 85% of the settlement funds. Doing so will maximize the local economic impact and the reduction of air pollution.

I encourage you to not use the funding for natural gas, propane or diesel vehicles. Further dependence on fossil fuels means more pollution. Only a transition to electric vehicles and investment in EV infrastructure will put us on the road to a 100% clean transportation sector in North Carolina.

Sincerely,

Susan Stiles
8408 Carolina Lily Lane
Charlotte, NC 28262
susanbennettstiles@gmail.com
(989) 860-5876

This message was sent by KnowWho, as a service provider only, on behalf of the individual noted in the sender information.

From: Mark Grooms (markobx@me.com) Sent You a Personal Message
To: [daq.NC_VWGrants](#)
Subject: [External] Use Volkswagen funds to electrify NC transportation
Date: Friday, December 22, 2017 5:24:43 AM

CAUTION: External email. Do not click links or open attachments unless verified. Send all suspicious email as an attachment to report.spam@nc.gov.

Dear Division of Air Quality,

I am writing to urge DEQ to wisely invest the \$92 million in Volkswagen settlement funds in electric vehicles and infrastructure. Taking advantage of these funds to jumpstart the electrification of North Carolina's transportation sector will mean less money sent out of state for petroleum, more in-state jobs, and cleaner air.

Specifically, I recommend that DEQ allocate the maximum allowable amount (15%) of the funds for electric vehicle charging infrastructure and installations. And I encourage DEQ to prioritize electric vehicles and buses for replacement whenever possible with the other 85% of the settlement funds. Doing so will maximize the local economic impact and the reduction of air pollution.

I encourage you to not use the funding for natural gas, propane or diesel vehicles. Further dependence on fossil fuels means more pollution. Only a transition to electric vehicles and investment in EV infrastructure will put us on the road to a 100% clean transportation sector in North Carolina.

Sincerely,

Mark Grooms
400 W Smith St, Apt 1B
Mark, NC 27401
markobx@me.com
(336) 681-3445

This message was sent by KnowWho, as a service provider only, on behalf of the individual noted in the sender information.

From: Mark Grooms (markobx@me.com) Sent You a Personal Message
To: [daq.NC_VWGrants](#)
Subject: [External] Use Volkswagen funds to electrify NC transportation
Date: Friday, December 22, 2017 5:24:33 AM

CAUTION: External email. Do not click links or open attachments unless verified. Send all suspicious email as an attachment to report.spam@nc.gov.

Dear Division of Air Quality,

I am writing to urge DEQ to wisely invest the \$92 million in Volkswagen settlement funds in electric vehicles and infrastructure. Taking advantage of these funds to jumpstart the electrification of North Carolina's transportation sector will mean less money sent out of state for petroleum, more in-state jobs, and cleaner air.

Specifically, I recommend that DEQ allocate the maximum allowable amount (15%) of the funds for electric vehicle charging infrastructure and installations. And I encourage DEQ to prioritize electric vehicles and buses for replacement whenever possible with the other 85% of the settlement funds. Doing so will maximize the local economic impact and the reduction of air pollution.

I encourage you to not use the funding for natural gas, propane or diesel vehicles. Further dependence on fossil fuels means more pollution. Only a transition to electric vehicles and investment in EV infrastructure will put us on the road to a 100% clean transportation sector in North Carolina.

Sincerely,

Mark Grooms
400 W Smith St, Apt 1B
Mark, NC 27401
markobx@me.com
(336) 681-3445

This message was sent by KnowWho, as a service provider only, on behalf of the individual noted in the sender information.

From: Mark Grooms (markobx@me.com) Sent You a Personal Message
To: [daq.NC_VWGrants](#)
Subject: [External] Use Volkswagen funds to electrify NC transportation
Date: Friday, December 22, 2017 5:23:53 AM

CAUTION: External email. Do not click links or open attachments unless verified. Send all suspicious email as an attachment to report.spam@nc.gov.

Dear Division of Air Quality,

I am writing to urge DEQ to wisely invest the \$92 million in Volkswagen settlement funds in electric vehicles and infrastructure. Taking advantage of these funds to jumpstart the electrification of North Carolina's transportation sector will mean less money sent out of state for petroleum, more in-state jobs, and cleaner air.

Specifically, I recommend that DEQ allocate the maximum allowable amount (15%) of the funds for electric vehicle charging infrastructure and installations. And I encourage DEQ to prioritize electric vehicles and buses for replacement whenever possible with the other 85% of the settlement funds. Doing so will maximize the local economic impact and the reduction of air pollution.

I encourage you to not use the funding for natural gas, propane or diesel vehicles. Further dependence on fossil fuels means more pollution. Only a transition to electric vehicles and investment in EV infrastructure will put us on the road to a 100% clean transportation sector in North Carolina.

Sincerely,

Mark Grooms
400 W Smith St, Apt 1B
Mark, NC 27401
markobx@me.com
(336) 681-3445

This message was sent by KnowWho, as a service provider only, on behalf of the individual noted in the sender information.

From: Mark Grooms (markobx@me.com) Sent You a Personal Message
To: [daq.NC_VWGrants](#)
Subject: [External] Use Volkswagen funds to electrify NC transportation
Date: Friday, December 22, 2017 5:23:34 AM

CAUTION: External email. Do not click links or open attachments unless verified. Send all suspicious email as an attachment to report.spam@nc.gov.

Dear Division of Air Quality,

I am writing to urge DEQ to wisely invest the \$92 million in Volkswagen settlement funds in electric vehicles and infrastructure. Taking advantage of these funds to jumpstart the electrification of North Carolina's transportation sector will mean less money sent out of state for petroleum, more in-state jobs, and cleaner air.

Specifically, I recommend that DEQ allocate the maximum allowable amount (15%) of the funds for electric vehicle charging infrastructure and installations. And I encourage DEQ to prioritize electric vehicles and buses for replacement whenever possible with the other 85% of the settlement funds. Doing so will maximize the local economic impact and the reduction of air pollution.

I encourage you to not use the funding for natural gas, propane or diesel vehicles. Further dependence on fossil fuels means more pollution. Only a transition to electric vehicles and investment in EV infrastructure will put us on the road to a 100% clean transportation sector in North Carolina.

Sincerely,

Mark Grooms
400 W Smith St, Apt 1B
Mark, NC 27401
markobx@me.com
(336) 681-3445

This message was sent by KnowWho, as a service provider only, on behalf of the individual noted in the sender information.

From: Emily Moran (moranemily42@gmail.com) Sent You a Personal Message
To: [daq.NC_VWGrants](#)
Subject: [External] Use Volkswagen funds to electrify NC transportation
Date: Friday, December 22, 2017 12:16:57 AM

CAUTION: External email. Do not click links or open attachments unless verified. Send all suspicious email as an attachment to report.spam@nc.gov.

Dear Division of Air Quality,

I am writing to urge DEQ to wisely invest the \$92 million in Volkswagen settlement funds in electric vehicles and infrastructure. Taking advantage of these funds to jumpstart the electrification of North Carolina's transportation sector will mean less money sent out of state for petroleum, more in-state jobs, and cleaner air.

Specifically, I recommend that DEQ allocate the maximum allowable amount (15%) of the funds for electric vehicle charging infrastructure and installations. And I encourage DEQ to prioritize electric vehicles and buses for replacement whenever possible with the other 85% of the settlement funds. Doing so will maximize the local economic impact and the reduction of air pollution.

I encourage you to not use the funding for natural gas, propane or diesel vehicles. Further dependence on fossil fuels means more pollution. Only a transition to electric vehicles and investment in EV infrastructure will put us on the road to a 100% clean transportation sector in North Carolina.

Sincerely,

Emily Moran
3651 Avocet Ct.
Merced, CA 95340
moranemily42@gmail.com
(209) 631-5194

This message was sent by KnowWho, as a service provider only, on behalf of the individual noted in the sender information.

From: Martha Brimm (mcb44444@aol.com) Sent You a Personal Message
To: [daq.NC_VWGrants](#)
Subject: [External] Use Volkswagen funds to electrify NC transportation
Date: Thursday, December 21, 2017 11:44:44 PM

CAUTION: External email. Do not click links or open attachments unless verified. Send all suspicious email as an attachment to report.spam@nc.gov.

Dear Division of Air Quality,

I am writing to urge DEQ to wisely invest the \$92 million in Volkswagen settlement funds in electric vehicles and infrastructure. Taking advantage of these funds to jumpstart the electrification of North Carolina's transportation sector will mean less money sent out of state for petroleum, more in-state jobs, and cleaner air.

Specifically, I recommend that DEQ allocate the maximum allowable amount (15%) of the funds for electric vehicle charging infrastructure and installations. And I encourage DEQ to prioritize electric vehicles and buses for replacement whenever possible with the other 85% of the settlement funds. Doing so will maximize the local economic impact and the reduction of air pollution.

I encourage you to not use the funding for natural gas, propane or diesel vehicles. Further dependence on fossil fuels means more pollution. Only a transition to electric vehicles and investment in EV infrastructure will put us on the road to a 100% clean transportation sector in North Carolina.

Sincerely,

Martha Brimm
7 Surrey Lane
Durham, NC 27707
mcb44444@aol.com
(919) 493-1775

This message was sent by KnowWho, as a service provider only, on behalf of the individual noted in the sender information.

From: Stephen Boletchek (sboletchek@gmail.com) Sent You a Personal Message
To: [daq.NC_VWGrants](#)
Subject: [External] Use Volkswagen funds to electrify NC transportation
Date: Thursday, December 21, 2017 8:28:14 PM

CAUTION: External email. Do not click links or open attachments unless verified. Send all suspicious email as an attachment to report.spam@nc.gov.

Dear Division of Air Quality,

I am writing to urge DEQ to wisely invest the \$92 million in Volkswagen settlement funds in electric vehicles and infrastructure. Taking advantage of these funds to jumpstart the electrification of North Carolina's transportation sector will mean less money sent out of state for petroleum, more in-state jobs, and cleaner air.

Specifically, I recommend that DEQ allocate the maximum allowable amount (15%) of the funds for electric vehicle charging infrastructure and installations. And I encourage DEQ to prioritize electric vehicles and buses for replacement whenever possible with the other 85% of the settlement funds. Doing so will maximize the local economic impact and the reduction of air pollution.

I encourage you to not use the funding for natural gas, propane or diesel vehicles. Further dependence on fossil fuels means more pollution. Only a transition to electric vehicles and investment in EV infrastructure will put us on the road to a 100% clean transportation sector in North Carolina.

Sincerely,

Stephen Boletchek
1106 Elbury Drive
Apex, NC 27502
sboletchek@gmail.com
(919) 387-9588

This message was sent by KnowWho, as a service provider only, on behalf of the individual noted in the sender information.

From: M.L. Rhodes (walkaboutlivin@gmail.com) Sent You a Personal Message
To: [daq.NC_VWGrants](#)
Subject: [External] Use Volkswagen to electrify NC transportation
Date: Thursday, December 21, 2017 4:07:21 PM

CAUTION: External email. Do not click links or open attachments unless verified. Send all suspicious email as an attachment to report.spam@nc.gov.

Dear Division of Air Quality,

I am writing to urge DEQ to wisely invest the \$92 million in Volkswagen settlement funds in electric vehicles and infrastructure. Taking advantage of these funds to jumpstart the electrification of North Carolina's transportation sector will mean less money sent out of state for petroleum, more in-state jobs, and cleaner air.

Specifically, I recommend that DEQ allocate the maximum allowable amount (15%) of the funds for electric vehicle charging infrastructure and installations. And I encourage DEQ to prioritize electric vehicles and buses for replacement whenever possible with the other 85% of the settlement funds. Doing so will maximize the local economic impact and the reduction of air pollution.

I encourage you to not use the funding for natural gas, propane or diesel vehicles. Further dependence on fossil fuels means more pollution. Only a transition to electric vehicles and investment in EV infrastructure will put us on the road to a 100% clean transportation sector in North Carolina.

Sincerely,

M.L. Rhodes
6917 Guy Johnson Lane
Raleigh, NC 27603
walkaboutlivin@gmail.com
(919) 772-8298

This message was sent by KnowWho, as a service provider only, on behalf of the individual noted in the sender information.

From: holly bower (hollybower@charter.net) Sent You a Personal Message
To: [daq.NC_VWGrants](#)
Subject: [External] Use Volkswagen funds to electrify NC transportation
Date: Thursday, December 21, 2017 4:00:20 PM

CAUTION: External email. Do not click links or open attachments unless verified. Send all suspicious email as an attachment to report.spam@nc.gov.

Dear Division of Air Quality,

I am writing to urge DEQ to wisely invest the \$92 million in Volkswagen settlement funds in electric vehicles and infrastructure. Taking advantage of these funds to jumpstart the electrification of North Carolina's transportation sector will mean less money sent out of state for petroleum, more in-state jobs, and cleaner air.

Specifically, I recommend that DEQ allocate the maximum allowable amount (15%) of the funds for electric vehicle charging infrastructure and installations. And I encourage DEQ to prioritize electric vehicles and buses for replacement whenever possible with the other 85% of the settlement funds. Doing so will maximize the local economic impact and the reduction of air pollution.

I encourage you to not use the funding for natural gas, propane or diesel vehicles. Further dependence on fossil fuels means more pollution. Only a transition to electric vehicles and investment in EV infrastructure will put us on the road to a 100% clean transportation sector in North Carolina.

Sincerely,

holly bower
100 Coxe Avenue
Asheville, NC 28801
hollybower@charter.net
(828) 254-2855

This message was sent by KnowWho, as a service provider only, on behalf of the individual noted in the sender information.

From: Deonna Angelillo (dbangelillo@gmail.com) Sent You a Personal Message
To: [daq.NC_VWGrants](#)
Subject: [External] Use Volkswagen funds to electrify NC transportation
Date: Thursday, December 21, 2017 3:06:40 PM

CAUTION: External email. Do not click links or open attachments unless verified. Send all suspicious email as an attachment to report.spam@nc.gov.

Dear Division of Air Quality,

I am writing to urge DEQ to wisely invest the \$92 million in Volkswagen settlement funds in electric vehicles and infrastructure. Taking advantage of these funds to jumpstart the electrification of North Carolina's transportation sector will mean less money sent out of state for petroleum, more in-state jobs, and cleaner air.

Specifically, I recommend that DEQ allocate the maximum allowable amount (15%) of the funds for electric vehicle charging infrastructure and installations. And I encourage DEQ to prioritize electric vehicles and buses for replacement whenever possible with the other 85% of the settlement funds. Doing so will maximize the local economic impact and the reduction of air pollution.

I encourage you to not use the funding for natural gas, propane or diesel vehicles. Further dependence on fossil fuels means more pollution. Only a transition to electric vehicles and investment in EV infrastructure will put us on the road to a 100% clean transportation sector in North Carolina.

Sincerely,

Deonna Angelillo
6604 Maynard Farm Roda
Chapel Hill, NC 27516
dbangelillo@gmail.com
(984) 974-1377

This message was sent by KnowWho, as a service provider only, on behalf of the individual noted in the sender information.

From: Doris Jackson (djdiva528@gmail.com) Sent You a Personal Message
To: [daq.NC_VWGrants](#)
Subject: [External] Use Volkswagen funds to electrify NC transportation
Date: Thursday, December 21, 2017 1:38:03 PM

CAUTION: External email. Do not click links or open attachments unless verified. Send all suspicious email as an attachment to report.spam@nc.gov.

Dear Division of Air Quality,

I am writing to urge DEQ to wisely invest the \$92 million in Volkswagen settlement funds in electric vehicles and infrastructure. Taking advantage of these funds to jumpstart the electrification of North Carolina's transportation sector will mean less money sent out of state for petroleum, more in-state jobs, and cleaner air.

Specifically, I recommend that DEQ allocate the maximum allowable amount (15%) of the funds for electric vehicle charging infrastructure and installations. And I encourage DEQ to prioritize electric vehicles and buses for replacement whenever possible with the other 85% of the settlement funds. Doing so will maximize the local economic impact and the reduction of air pollution.

I encourage you to not use the funding for natural gas, propane or diesel vehicles. Further dependence on fossil fuels means more pollution. Only a transition to electric vehicles and investment in EV infrastructure will put us on the road to a 100% clean transportation sector in North Carolina.

Sincerely,

Doris Jackson
5405 Wheatcross
Raleigh, NC 27610
djdiva528@gmail.com
(919) 612-6968

This message was sent by KnowWho, as a service provider only, on behalf of the individual noted in the sender information.

From: Donald Zellmer (donald.zellmer@gmail.com) Sent You a Personal Message
To: [daq.NC_VWGrants](#)
Subject: [External] Use Volkswagen funds to electrify NC transportation
Date: Thursday, December 21, 2017 1:22:51 PM

CAUTION: External email. Do not click links or open attachments unless verified. Send all suspicious email as an attachment to report.spam@nc.gov.

Dear Division of Air Quality,

I am writing to urge DEQ to wisely invest the \$92 million in Volkswagen settlement funds in electric vehicles and infrastructure. Taking advantage of these funds to jumpstart the electrification of North Carolina's transportation sector will mean less money sent out of state for petroleum, more in-state jobs, and cleaner air.

Specifically, I recommend that DEQ allocate the maximum allowable amount (15%) of the funds for electric vehicle charging infrastructure and installations. And I encourage DEQ to prioritize electric vehicles and buses for replacement whenever possible with the other 85% of the settlement funds. Doing so will maximize the local economic impact and the reduction of air pollution.

I encourage you to not use the funding for natural gas, propane or diesel vehicles. Further dependence on fossil fuels means more pollution. Only a transition to electric vehicles and investment in EV infrastructure will put us on the road to a 100% clean transportation sector in North Carolina.

Sincerely,

Donald Zellmer
142 Grants Home Trl
Donald, NC 27007
donald.zellmer@gmail.com
(336) 408-6590

This message was sent by KnowWho, as a service provider only, on behalf of the individual noted in the sender information.

From: Rob Davey (robdavey@msn.com) Sent You a Personal Message
To: [daq.NC_VWGrants](#)
Subject: [External] Use Volkswagen funds to electrify NC transportation
Date: Thursday, December 21, 2017 1:18:42 PM

CAUTION: External email. Do not click links or open attachments unless verified. Send all suspicious email as an attachment to report.spam@nc.gov.

Dear Division of Air Quality,

I am writing to urge DEQ to wisely invest the \$92 million in Volkswagen settlement funds in electric vehicles and infrastructure. Taking advantage of these funds to jumpstart the electrification of North Carolina's transportation sector will mean less money sent out of state for petroleum, more in-state jobs, and cleaner air.

Specifically, I recommend that DEQ allocate the maximum allowable amount (15%) of the funds for electric vehicle charging infrastructure and installations. And I encourage DEQ to prioritize electric vehicles and buses for replacement whenever possible with the other 85% of the settlement funds. Doing so will maximize the local economic impact and the reduction of air pollution.

I encourage you to not use the funding for natural gas, propane or diesel vehicles. Further dependence on fossil fuels means more pollution. Only a transition to electric vehicles and investment in EV infrastructure will put us on the road to a 100% clean transportation sector in North Carolina.

Sincerely,

Rob Davey
902 Emerald Court
Corolla, NC 27927
robdavey@msn.com
(443) 831-2544

This message was sent by KnowWho, as a service provider only, on behalf of the individual noted in the sender information.

From: Lauren Trull (lashley8386@gmail.com) Sent You a Personal Message
To: [daq.NC_VWGrants](#)
Subject: [External] Use Volkswagen funds to electrify NC transportation
Date: Thursday, December 21, 2017 9:28:18 AM

CAUTION: External email. Do not click links or open attachments unless verified. Send all suspicious email as an attachment to report.spam@nc.gov.

Dear Division of Air Quality,

I am writing to urge DEQ to wisely invest the \$92 million in Volkswagen settlement funds in electric vehicles and infrastructure. Taking advantage of these funds to jumpstart the electrification of North Carolina's transportation sector will mean less money sent out of state for petroleum, more in-state jobs, and cleaner air.

Specifically, I recommend that DEQ allocate the maximum allowable amount (15%) of the funds for electric vehicle charging infrastructure and installations. And I encourage DEQ to prioritize electric vehicles and buses for replacement whenever possible with the other 85% of the settlement funds. Doing so will maximize the local economic impact and the reduction of air pollution.

I encourage you to not use the funding for natural gas, propane or diesel vehicles. Further dependence on fossil fuels means more pollution. Only a transition to electric vehicles and investment in EV infrastructure will put us on the road to a 100% clean transportation sector in North Carolina.

Sincerely,

Lauren Trull
282 Incinerator Rd.
Clyde, NC 28721
lashley8386@gmail.com
(828) 926-5234

This message was sent by KnowWho, as a service provider only, on behalf of the individual noted in the sender information.

From: Ulrich Alsentzer (ualsentzer@gotricounty.com) Sent You a Personal Message
To: [daq.NC_VWGrants](#)
Subject: [External] 111(d)
Date: Thursday, December 21, 2017 9:17:53 AM

CAUTION: External email. Do not click links or open attachments unless verified. Send all suspicious email as an attachment to report.spam@nc.gov.

Dear Division of Air Quality,

I am writing to urge DEQ to wisely invest the \$92 million in Volkswagen settlement funds in electric vehicles and infrastructure. Taking advantage of these funds to jumpstart the electrification of North Carolina's transportation sector will mean less money sent out of state for petroleum, more in-state jobs, and cleaner air.

Specifically, I recommend that DEQ allocate the maximum allowable amount (15%) of the funds for electric vehicle charging infrastructure and installations. And I encourage DEQ to prioritize electric vehicles and buses for replacement whenever possible with the other 85% of the settlement funds. Doing so will maximize the local economic impact and the reduction of air pollution.

I encourage you to not use the funding for natural gas, propane or diesel vehicles. Further dependence on fossil fuels means more pollution. Only a transition to electric vehicles and investment in EV infrastructure will put us on the road to a 100% clean transportation sector in North Carolina.

Sincerely,

Ulrich Alsentzer
103 Cabana Rd
Ulrich, NC 27810
ualsentzer@gotricounty.com
(252) 964-4624

This message was sent by KnowWho, as a service provider only, on behalf of the individual noted in the sender information.

From: Cynthia Eckroth (cseckroth13@gmail.com) Sent You a Personal Message
To: daq.NC_VWGrants
Subject: [External] Use Volkswagen funds to electrify NC transportation
Date: Thursday, December 21, 2017 7:25:25 AM

CAUTION: External email. Do not click links or open attachments unless verified. Send all suspicious email as an attachment to report.spam@nc.gov.

Dear Division of Air Quality,

I am writing to urge DEQ to wisely invest the \$92 million in Volkswagen settlement funds in electric vehicles and infrastructure. Taking advantage of these funds to jumpstart the electrification of North Carolina's transportation sector will mean less money sent out of state for petroleum, more in-state jobs, and cleaner air.

Specifically, I recommend that DEQ allocate the maximum allowable amount (15%) of the funds for electric vehicle charging infrastructure and installations. And I encourage DEQ to prioritize electric vehicles and buses for replacement whenever possible with the other 85% of the settlement funds. Doing so will maximize the local economic impact and the reduction of air pollution.

I encourage you to not use the funding for natural gas, propane or diesel vehicles. Further dependence on fossil fuels means more pollution. Only a transition to electric vehicles and investment in EV infrastructure will put us on the road to a 100% clean transportation sector in North Carolina.

Sincerely,

Cynthia Eckroth
160 Rock springs church rd
Pittsboro, NC 27312
cseckroth13@gmail.com
(505) 440-8389

This message was sent by KnowWho, as a service provider only, on behalf of the individual noted in the sender information.

From: Linda McGowen (l_mcgowen@hotmail.com) Sent You a Personal Message
To: [daq.NC_VWGrants](#)
Subject: [External] Use Volkswagen funds to electrify NC transportation
Date: Thursday, December 21, 2017 7:10:13 AM

CAUTION: External email. Do not click links or open attachments unless verified. Send all suspicious email as an attachment to report.spam@nc.gov.

Dear Division of Air Quality,

I am writing to urge DEQ to wisely invest the \$92 million in Volkswagen settlement funds in electric vehicles and infrastructure. Taking advantage of these funds to jumpstart the electrification of North Carolina's transportation sector will mean less money sent out of state for petroleum, more in-state jobs, and cleaner air.

Specifically, I recommend that DEQ allocate the maximum allowable amount (15%) of the funds for electric vehicle charging infrastructure and installations. And I encourage DEQ to prioritize electric vehicles and buses for replacement whenever possible with the other 85% of the settlement funds. Doing so will maximize the local economic impact and the reduction of air pollution.

I encourage you to not use the funding for natural gas, propane or diesel vehicles. Further dependence on fossil fuels means more pollution. Only a transition to electric vehicles and investment in EV infrastructure will put us on the road to a 100% clean transportation sector in North Carolina.

Sincerely,

Linda McGowen
964 New Haw Creek Rd
Asheville, NC 28805
l_mcgowen@hotmail.com
(252) 354-2444

This message was sent by KnowWho, as a service provider only, on behalf of the individual noted in the sender information.

From: Robert James (rejames42251@charter.net) Sent You a Personal Message
To: [daq.NC_VWGrants](#)
Subject: [External] Use Volkswagen funds to electrify NC transportation
Date: Thursday, December 21, 2017 7:05:24 AM

CAUTION: External email. Do not click links or open attachments unless verified. Send all suspicious email as an attachment to report.spam@nc.gov.

Dear Division of Air Quality,

I am writing to urge DEQ to wisely invest the \$92 million in Volkswagen settlement funds in electric vehicles and infrastructure. Taking advantage of these funds to jumpstart the electrification of North Carolina's transportation sector will mean less money sent out of state for petroleum, more in-state jobs, and cleaner air.

Specifically, I recommend that DEQ allocate the maximum allowable amount (15%) of the funds for electric vehicle charging infrastructure and installations. And I encourage DEQ to prioritize electric vehicles and buses for replacement whenever possible with the other 85% of the settlement funds. Doing so will maximize the local economic impact and the reduction of air pollution.

I encourage you to not use the funding for natural gas, propane or diesel vehicles. Further dependence on fossil fuels means more pollution. Only a transition to electric vehicles and investment in EV infrastructure will put us on the road to a 100% clean transportation sector in North Carolina.

Sincerely,

Robert James
2Ayr Ct
Arden, NC 28704
rejames42251@charter.net
(865) 789-0348

This message was sent by KnowWho, as a service provider only, on behalf of the individual noted in the sender information.

From: Connie Raper (ckrmib@nc.rr.com) Sent You a Personal Message
To: [daq.NC_VWGrants](#)
Subject: [External] Use Volkswagen funds to electrify NC transportation
Date: Thursday, December 21, 2017 2:12:35 AM

CAUTION: External email. Do not click links or open attachments unless verified. Send all suspicious email as an attachment to report.spam@nc.gov.

Dear Division of Air Quality,

I am writing to urge DEQ to wisely invest the \$92 million in Volkswagen settlement funds in electric vehicles and infrastructure. Taking advantage of these funds to jumpstart the electrification of North Carolina's transportation sector will mean less money sent out of state for petroleum, more in-state jobs, and cleaner air.

Specifically, I recommend that DEQ allocate the maximum allowable amount (15%) of the funds for electric vehicle charging infrastructure and installations. And I encourage DEQ to prioritize electric vehicles and buses for replacement whenever possible with the other 85% of the settlement funds. Doing so will maximize the local economic impact and the reduction of air pollution.

I encourage you to not use the funding for natural gas, propane or diesel vehicles. Further dependence on fossil fuels means more pollution. Only a transition to electric vehicles and investment in EV infrastructure will put us on the road to a 100% clean transportation sector in North Carolina.

Sincerely,

Connie Raper
2614 Woodmont dr
Durham, NC 27705
ckrmib@nc.rr.com
(919) 698-3282

This message was sent by KnowWho, as a service provider only, on behalf of the individual noted in the sender information.

From: Martha Spencer (spencer_martha@hotmail.com) Sent You a Personal Message
To: [daq.NC_VWGrants](#)
Subject: [External] Use Volkswagen funds to electrify NC transportation
Date: Thursday, December 21, 2017 12:32:09 AM

CAUTION: External email. Do not click links or open attachments unless verified. Send all suspicious email as an attachment to report.spam@nc.gov.

Dear Division of Air Quality,

I am writing to urge DEQ to wisely invest the \$92 million in Volkswagen settlement funds in electric vehicles and infrastructure. Taking advantage of these funds to jumpstart the electrification of North Carolina's transportation sector will mean less money sent out of state for petroleum, more in-state jobs, and cleaner air.

Specifically, I recommend that DEQ allocate the maximum allowable amount (15%) of the funds for electric vehicle charging infrastructure and installations. And I encourage DEQ to prioritize electric vehicles and buses for replacement whenever possible with the other 85% of the settlement funds. Doing so will maximize the local economic impact and the reduction of air pollution.

I encourage you to not use the funding for natural gas, propane or diesel vehicles. Further dependence on fossil fuels means more pollution. Only a transition to electric vehicles and investment in EV infrastructure will put us on the road to a 100% clean transportation sector in North Carolina.

Sincerely,

Martha Spencer
988 Henry Mountain Road
Brevard, NC 28712
spencer_martha@hotmail.com
(828) 885-2680

This message was sent by KnowWho, as a service provider only, on behalf of the individual noted in the sender information.

From: Gary Simpson (gsimpson@nc.rr.com) Sent You a Personal Message
To: [daq.NC_VWGrants](#)
Subject: [External] Use Volkswagen funds to electrify NC transportation
Date: Wednesday, December 20, 2017 10:09:09 PM

CAUTION: External email. Do not click links or open attachments unless verified. Send all suspicious email as an attachment to report.spam@nc.gov.

Dear Division of Air Quality,

I am writing to urge DEQ to wisely invest the \$92 million in Volkswagen settlement funds in electric vehicles and infrastructure. Taking advantage of these funds to jumpstart the electrification of North Carolina's transportation sector will mean less money sent out of state for petroleum, more in-state jobs, and cleaner air.

Specifically, I recommend that DEQ allocate the maximum allowable amount (15%) of the funds for electric vehicle charging infrastructure and installations. And I encourage DEQ to prioritize electric vehicles and buses for replacement whenever possible with the other 85% of the settlement funds. Doing so will maximize the local economic impact and the reduction of air pollution.

I encourage you to NOT use the funding for natural gas, propane or diesel vehicles. Further dependence on fossil fuels means more pollution. Only a transition to electric vehicles and investment in EV infrastructure will put us on the road to a 100% clean transportation sector in North Carolina.

Sincerely,

Gary Simpson
82 Cynthia Ln
Pittsboro, NC 27312
gsimpson@nc.rr.com
(919) 542-5628

This message was sent by KnowWho, as a service provider only, on behalf of the individual noted in the sender information.

From: Benjamin Vann (bvann29@gmail.com) Sent You a Personal Message
To: [daq.NC_VWGrants](#)
Subject: [External] Use Volkswagen funds to electrify NC transportation
Date: Wednesday, December 20, 2017 9:55:27 PM

CAUTION: External email. Do not click links or open attachments unless verified. Send all suspicious email as an attachment to report.spam@nc.gov.

Dear Division of Air Quality,

I am writing to urge DEQ to wisely invest the \$92 million in Volkswagen settlement funds in electric vehicles and infrastructure. Taking advantage of these funds to jump start North Carolina's transportation sector will mean less money sent out of state for petroleum, more in-state jobs, and cleaner air.

Specifically, I recommend that DEQ allocate the maximum allowable amount (15%) of the funds for electric vehicle charging infrastructure and installations. And I encourage DEQ to prioritize electric vehicles and buses for replacement whenever possible with the other 85% of the settlement funds. Doing so will maximize the local economic impact and the reduction of air pollution.

I encourage you to not use the funding for natural gas, propane or diesel vehicles. Further dependence on fossil fuels means more pollution. Only a transition to electric vehicles and investment in EV infrastructure will put us on the road to a 100% clean transportation sector in North Carolina.

Sincerely,

Benjamin Vann
118 Stonemark CT
Jacksonville, NC 11236
bvann29@gmail.com
(910) 449-4321

This message was sent by KnowWho, as a service provider only, on behalf of the individual noted in the sender information.

From: Jennifer Dallas (jmdallas0633@gmail.com) Sent You a Personal Message
To: [daq.NC_VWGrants](#)
Subject: [External] Use Volkswagen funds to electrify NC transportation
Date: Wednesday, December 20, 2017 8:43:38 PM

CAUTION: External email. Do not click links or open attachments unless verified. Send all suspicious email as an attachment to report.spam@nc.gov.

Dear Division of Air Quality,

I am writing to urge DEQ to wisely invest the \$92 million in Volkswagen settlement funds in electric vehicles and infrastructure. Taking advantage of these funds to jumpstart the electrification of North Carolina's transportation sector will mean less money sent out of state for petroleum, more in-state jobs, and cleaner air.

Specifically, I recommend that DEQ allocate the maximum allowable amount (15%) of the funds for electric vehicle charging infrastructure and installations. And I encourage DEQ to prioritize electric vehicles and buses for replacement whenever possible with the other 85% of the settlement funds. Doing so will maximize the local economic impact and the reduction of air pollution.

I encourage you to not use the funding for natural gas, propane or diesel vehicles. Further dependence on fossil fuels means more pollution. Only a transition to electric vehicles and investment in EV infrastructure will put us on the road to a 100% clean transportation sector in North Carolina.

Sincerely,

Jennifer Dallas
502 Plum Nearly Lane, Apt. B
Wilmington, NC 28403
jmdallas0633@gmail.com
(910) 549-1888

This message was sent by KnowWho, as a service provider only, on behalf of the individual noted in the sender information.

From: Joan Jobsis (joanjobsis@gmail.com) Sent You a Personal Message
To: [daq.NC_VWGrants](#)
Subject: [External] Use Volkswagen funds to electrify NC transportation
Date: Wednesday, December 20, 2017 8:21:17 PM

CAUTION: External email. Do not click links or open attachments unless verified. Send all suspicious email as an attachment to report.spam@nc.gov.

Dear Division of Air Quality,

I am writing to urge DEQ to wisely invest the \$92 million in Volkswagen settlement funds in electric vehicles and infrastructure. Taking advantage of these funds to jumpstart the electrification of North Carolina's transportation sector will mean less money sent out of state for petroleum, more in-state jobs, and cleaner air.

Specifically, I recommend that DEQ allocate the maximum allowable amount (15%) of the funds for electric vehicle charging infrastructure and installations. And I encourage DEQ to prioritize electric vehicles and buses for replacement whenever possible with the other 85% of the settlement funds. Doing so will maximize the local economic impact and the reduction of air pollution.

I encourage you to not use the funding for natural gas, propane or diesel vehicles. Further dependence on fossil fuels means more pollution. Only a transition to electric vehicles and investment in EV infrastructure will put us on the road to a 100% clean transportation sector in North Carolina.

Sincerely,

Joan Jobsis
821 Footbridge Place
Cary, NC 27519
joanjobsis@gmail.com
(919) 600-2440

This message was sent by KnowWho, as a service provider only, on behalf of the individual noted in the sender information.

From: Monica Sanchez (monica.northcarolina@yahoo.com) Sent You a Personal Message
To: [daq.NC_VWGrants](#)
Subject: [External] Use Volkswagen funds to electrify NC transportation
Date: Wednesday, December 20, 2017 8:18:48 PM

CAUTION: External email. Do not click links or open attachments unless verified. Send all suspicious email as an attachment to report.spam@nc.gov.

Dear Division of Air Quality,

I am writing to urge DEQ to wisely invest the \$92 million in Volkswagen settlement funds in electric vehicles and infrastructure. Taking advantage of these funds to jumpstart the electrification of North Carolina's transportation sector will mean less money sent out of state for petroleum, more in-state jobs, and cleaner air.

Specifically, I recommend that DEQ allocate the maximum allowable amount (15%) of the funds for electric vehicle charging infrastructure and installations. And I encourage DEQ to prioritize electric vehicles and buses for replacement whenever possible with the other 85% of the settlement funds. Doing so will maximize the local economic impact and the reduction of air pollution.

I encourage you to not use the funding for natural gas, propane or diesel vehicles. Further dependence on fossil fuels means more pollution. Only a transition to electric vehicles and investment in EV infrastructure will put us on the road to a 100% clean transportation sector in North Carolina.

Sincerely,

Monica Sanchez
64 Cedar Hills Cir.
Chapel Hill, NC 27514
monica.northcarolina@yahoo.com
(919) 968-6115

This message was sent by KnowWho, as a service provider only, on behalf of the individual noted in the sender information.

From: Barbara Benson (barbbenson@ec.rr.com) Sent You a Personal Message
To: daq.NC_VWGrants
Subject: [External] Use Volkswagen funds to electrify NC transportation
Date: Wednesday, December 20, 2017 7:58:50 PM

CAUTION: External email. Do not click links or open attachments unless verified. Send all suspicious email as an attachment to report.spam@nc.gov.

Dear Division of Air Quality,

I am writing to urge DEQ to wisely invest the \$92 million in Volkswagen settlement funds in electric vehicles and infrastructure. Taking advantage of these funds to jumpstart the electrification of North Carolina's transportation sector will mean less money sent out of state for petroleum, more in-state jobs, and cleaner air.

Specifically, I recommend that DEQ allocate the maximum allowable amount (15%) of the funds for electric vehicle charging infrastructure and installations. And I encourage DEQ to prioritize electric vehicles and buses for replacement whenever possible with the other 85% of the settlement funds. Doing so will maximize the local economic impact and the reduction of air pollution.

I encourage you to not use the funding for natural gas, propane or diesel vehicles. Further dependence on fossil fuels means more pollution. Only a transition to electric vehicles and investment in EV infrastructure will put us on the road to a 100% clean transportation sector in North Carolina.

Sincerely,

Barbara Benson
104 Deerfield Ct
Cedar Point, NC 28584
barbbenson@ec.rr.com
(252) 393-6495

This message was sent by KnowWho, as a service provider only, on behalf of the individual noted in the sender information.

From: MICHAEL HUGHES (mh87@charter.net) Sent You a Personal Message
To: daq.NC_VWGrants
Subject: [External] Use Volkswagen funds to electrify NC transportation
Date: Wednesday, December 20, 2017 7:25:32 PM

CAUTION: External email. Do not click links or open attachments unless verified. Send all suspicious email as an attachment to report.spam@nc.gov.

Dear Division of Air Quality,

I am writing to urge DEQ to wisely invest the \$92 million in Volkswagen settlement funds in electric vehicles and infrastructure. Taking advantage of these funds to jumpstart the electrification of North Carolina's transportation sector will mean less money sent out of state for petroleum, more in-state jobs, and cleaner air.

Specifically, I recommend that DEQ allocate the maximum allowable amount (15%) of the funds for electric vehicle charging infrastructure and installations. And I encourage DEQ to prioritize electric vehicles and buses for replacement whenever possible with the other 85% of the settlement funds. Doing so will maximize the local economic impact and the reduction of air pollution.

I encourage you to not use the funding for natural gas, propane or diesel vehicles. Further dependence on fossil fuels means more pollution. Only a transition to electric vehicles and investment in EV infrastructure will put us on the road to a 100% clean transportation sector in North Carolina.

Sincerely,

MICHAEL HUGHES
PO Box 71, 87 snowbird
Linville, NC 28646
mh87@charter.net
(828) 733-5224

This message was sent by KnowWho, as a service provider only, on behalf of the individual noted in the sender information.

From: J S (jillslee@aol.com) Sent You a Personal Message
To: [daq.NC_VWGrants](#)
Subject: [External] Use Volkswagen funds to electrify NC transportation
Date: Wednesday, December 20, 2017 7:02:06 PM

CAUTION: External email. Do not click links or open attachments unless verified. Send all suspicious email as an attachment to report.spam@nc.gov.

Dear Division of Air Quality,

I am writing to urge DEQ to wisely invest the \$92 million in Volkswagen settlement funds in electric vehicles and infrastructure. Taking advantage of these funds to jumpstart the electrification of North Carolina's transportation sector will mean less money sent out of state for petroleum, more in-state jobs, and cleaner air.

Specifically, I recommend that DEQ allocate the maximum allowable amount (15%) of the funds for electric vehicle charging infrastructure and installations. And I encourage DEQ to prioritize electric vehicles and buses for replacement whenever possible with the other 85% of the settlement funds. Doing so will maximize the local economic impact and the reduction of air pollution.

I encourage you to not use the funding for natural gas, propane or diesel vehicles. Further dependence on fossil fuels means more pollution. Only a transition to electric vehicles and investment in EV infrastructure will put us on the road to a 100% clean transportation sector in North Carolina.

Sincerely,

J S
14535 Harmonious St
Charlotte, NC 28278
jillslee@aol.com
(704) 643-9035

This message was sent by KnowWho, as a service provider only, on behalf of the individual noted in the sender information.

From: Patricia Lee (patricia_lee@yahoo.com) Sent You a Personal Message
To: [daq.NC_VWGrants](#)
Subject: [External] Use Volkswagen funds to electrify NC transportation
Date: Wednesday, December 20, 2017 6:28:33 PM

CAUTION: External email. Do not click links or open attachments unless verified. Send all suspicious email as an attachment to report.spam@nc.gov.

Dear Division of Air Quality,

I am writing to urge DEQ to wisely invest the \$92 million in Volkswagen settlement funds in electric vehicles and infrastructure. Taking advantage of these funds to jumpstart the electrification of North Carolina's transportation sector will mean less money sent out of state for petroleum, more in-state jobs, and cleaner air.

Specifically, I recommend that DEQ allocate the maximum allowable amount (15%) of the funds for electric vehicle charging infrastructure and installations. And I encourage DEQ to prioritize electric vehicles and buses for replacement whenever possible with the other 85% of the settlement funds. Doing so will maximize the local economic impact and the reduction of air pollution.

I encourage you to not use the funding for natural gas, propane or diesel vehicles. Further dependence on fossil fuels means more pollution. Only a transition to electric vehicles and investment in EV infrastructure will put us on the road to a 100% clean transportation sector in North Carolina.

Sincerely,

Patricia Lee
2053 10th st Ln NW
Hickory, NC 28601
patricia_lee@yahoo.com
(828) 855-3412

This message was sent by KnowWho, as a service provider only, on behalf of the individual noted in the sender information.

From: Marcia Kane (marciek2@gmail.com) Sent You a Personal Message
To: daq.NC_VWGrants
Subject: [External] Use Volkswagen funds to electrify NC transportation
Date: Wednesday, December 20, 2017 6:27:27 PM

CAUTION: External email. Do not click links or open attachments unless verified. Send all suspicious email as an attachment to report.spam@nc.gov.

Dear Division of Air Quality,

I am writing to urge DEQ to wisely invest the \$92 million in Volkswagen settlement funds in electric vehicles and infrastructure. Taking advantage of these funds to jumpstart the electrification of North Carolina's transportation sector will mean less money sent out of state for petroleum, more in-state jobs, and cleaner air.

Specifically, I recommend that DEQ allocate the maximum allowable amount (15%) of the funds for electric vehicle charging infrastructure and installations. And I encourage DEQ to prioritize electric vehicles and buses for replacement whenever possible with the other 85% of the settlement funds. Doing so will maximize the local economic impact and the reduction of air pollution.

I encourage you to not use the funding for natural gas, propane or diesel vehicles. Further dependence on fossil fuels means more pollution. Only a transition to electric vehicles and investment in EV infrastructure will put us on the road to a 100% clean transportation sector in North Carolina.

Sincerely,

Marcia Kane
1050 Carousel Ln
Hendersonville, NC 28792
marciek2@gmail.com
(828) 698-8805

This message was sent by KnowWho, as a service provider only, on behalf of the individual noted in the sender information.

From: Donna Durfee (dddurfee@msn.com) Sent You a Personal Message
To: [daq.NC_VWGrants](#)
Subject: [External] Use Volkswagen funds to electrify NC transportation
Date: Wednesday, December 20, 2017 6:22:19 PM

CAUTION: External email. Do not click links or open attachments unless verified. Send all suspicious email as an attachment to report.spam@nc.gov.

Dear Division of Air Quality,

I am writing to urge DEQ to wisely invest the \$92 million in Volkswagen settlement funds in electric vehicles and infrastructure. Taking advantage of these funds to jumpstart the electrification of North Carolina's transportation sector will mean less money sent out of state for petroleum, more in-state jobs, and cleaner air.

Specifically, I recommend that DEQ allocate the maximum allowable amount (15%) of the funds for electric vehicle charging infrastructure and installations. And I encourage DEQ to prioritize electric vehicles and buses for replacement whenever possible with the other 85% of the settlement funds. Doing so will maximize the local economic impact and the reduction of air pollution.

I encourage you to not use the funding for natural gas, propane or diesel vehicles. Further dependence on fossil fuels means more pollution. Only a transition to electric vehicles and investment in EV infrastructure will put us on the road to a 100% clean transportation sector in North Carolina.

Sincerely,

Donna Durfee
2100 Collingdale Pl
Charlotte, NC 28210
dddurfee@msn.com
(704) 553-7321

This message was sent by KnowWho, as a service provider only, on behalf of the individual noted in the sender information.

From: Richard Honeycutt (rhoneycutt@alumni.wfu.edu) Sent You a Personal Message
To: [daq.NC_VWGrants](#)
Subject: [External] Use Volkswagen funds to electrify NC transportation
Date: Wednesday, December 20, 2017 5:34:29 PM

CAUTION: External email. Do not click links or open attachments unless verified. Send all suspicious email as an attachment to report.spam@nc.gov.

Dear Division of Air Quality,

I am writing to urge DEQ to wisely invest the \$92 million in Volkswagen settlement funds in electric vehicles and infrastructure. Taking advantage of these funds to jumpstart the electrification of North Carolina's transportation sector will mean less money sent out of state for petroleum, more in-state jobs, and cleaner air.

Specifically, I recommend that DEQ allocate the maximum allowable amount (15%) of the funds for electric vehicle charging infrastructure and installations. And I encourage DEQ to prioritize electric vehicles and buses for replacement whenever possible with the other 85% of the settlement funds. Doing so will maximize the local economic impact and the reduction of air pollution.

I encourage you to not use the funding for natural gas, propane or diesel vehicles. Further dependence on fossil fuels means more pollution. Only a transition to electric vehicles and investment in EV infrastructure will put us on the road to a 100% clean transportation sector in North Carolina.

Sincerely,

Richard Honeycutt
404 Olivia Drive
Lexington, NC 27295
rhoneycutt@alumni.wfu.edu
(336) 249-3526

This message was sent by KnowWho, as a service provider only, on behalf of the individual noted in the sender information.

From: Judith Mesko (judymesko@hotmail.com) Sent You a Personal Message
To: daq.NC_VWGrants
Subject: [External] Use Volkswagen funds to electrify NC transportation
Date: Wednesday, December 20, 2017 5:25:02 PM

CAUTION: External email. Do not click links or open attachments unless verified. Send all suspicious email as an attachment to report.spam@nc.gov.

Dear Division of Air Quality,

I am writing to urge DEQ to wisely invest the \$92 million in Volkswagen settlement funds in electric vehicles and infrastructure. Taking advantage of these funds to jumpstart the electrification of North Carolina's transportation sector will mean less money sent out of state for petroleum, more in-state jobs, and cleaner air.

Specifically, I recommend that DEQ allocate the maximum allowable amount (15%) of the funds for electric vehicle charging infrastructure and installations. And I encourage DEQ to prioritize electric vehicles and buses for replacement whenever possible with the other 85% of the settlement funds. Doing so will maximize the local economic impact and the reduction of air pollution.

I encourage you to not use the funding for natural gas, propane or diesel vehicles. Further dependence on fossil fuels means more pollution. Only a transition to electric vehicles and investment in EV infrastructure will put us on the road to a 100% clean transportation sector in North Carolina.

Sincerely,

Judith Mesko
327 Clifton Road
Rocky Mount, NC 27804
judymesko@hotmail.com
(252) 212-3557

This message was sent by KnowWho, as a service provider only, on behalf of the individual noted in the sender information.

From: Ronald Campbell (curmudgeon101@comcast.net) Sent You a Personal Message
To: [daq.NC_VWGrants](#)
Subject: [External] Use Volkswagen funds to electrify NC transportation
Date: Wednesday, December 20, 2017 5:17:38 PM

CAUTION: External email. Do not click links or open attachments unless verified. Send all suspicious email as an attachment to report.spam@nc.gov.

Dear Division of Air Quality,

I am writing to urge DEQ to wisely invest the \$92 million in Volkswagen settlement funds in electric vehicles and infrastructure. Taking advantage of these funds to jumpstart the electrification of North Carolina's transportation sector will mean less money sent out of state for petroleum, more in-state jobs, and cleaner air.

Specifically, I recommend that DEQ allocate the maximum allowable amount (15%) of the funds for electric vehicle charging infrastructure and installations. And I encourage DEQ to prioritize electric vehicles and buses for replacement whenever possible with the other 85% of the settlement funds. Doing so will maximize the local economic impact and the reduction of air pollution.

I encourage you to not use the funding for natural gas, propane or diesel vehicles. Further dependence on fossil fuels means more pollution. Only a transition to electric vehicles and investment in EV infrastructure will put us on the road to a 100% clean transportation sector in North Carolina.

Sincerely,

Ronald Campbell
100 Victoria Court
Point Harbor, NC 27964
curmudgeon101@comcast.net
(724) 951-4436

This message was sent by KnowWho, as a service provider only, on behalf of the individual noted in the sender information.

From: Randal Kempka (rkempka@carolina.rr.com) Sent You a Personal Message
To: [daq.NC_VWGrants](#)
Subject: [External] Use Volkswagen funds to electrify NC transportation
Date: Wednesday, December 20, 2017 5:16:18 PM

CAUTION: External email. Do not click links or open attachments unless verified. Send all suspicious email as an attachment to report.spam@nc.gov.

Dear Division of Air Quality,

I am writing to urge DEQ to wisely invest the \$92 million in Volkswagen settlement funds in electric vehicles and infrastructure. Taking advantage of these funds to jumpstart the electrification of North Carolina's transportation sector will mean less money sent out of state for petroleum, more in-state jobs, and cleaner air.

Specifically, I recommend that DEQ allocate the maximum allowable amount (15%) of the funds for electric vehicle charging infrastructure and installations. And I encourage DEQ to prioritize electric vehicles and buses for replacement whenever possible with the other 85% of the settlement funds. Doing so will maximize the local economic impact and the reduction of air pollution.

I encourage you to not use the funding for natural gas, propane or diesel vehicles. Further dependence on fossil fuels means more pollution. Only a transition to electric vehicles and investment in EV infrastructure will put us on the road to a 100% clean transportation sector in North Carolina.

Sincerely,

Randal Kempka
10018 White Cascade Drive
Charlotte, NC 28269
rkempka@carolina.rr.com
(704) 595-1776

This message was sent by KnowWho, as a service provider only, on behalf of the individual noted in the sender information.

From: Judy Smith (jsnorkel23@gmail.com) Sent You a Personal Message
To: [daq.NC_VWGrants](#)
Subject: [External] Use Volkswagen funds to electrify NC transportation
Date: Wednesday, December 20, 2017 4:56:02 PM

CAUTION: External email. Do not click links or open attachments unless verified. Send all suspicious email as an attachment to report.spam@nc.gov.

Dear Division of Air Quality,

I am writing to urge DEQ to wisely invest the \$92 million in Volkswagen settlement funds in electric vehicles and infrastructure. Taking advantage of these funds to jumpstart the electrification of North Carolina's transportation sector will mean less money sent out of state for petroleum, more in-state jobs, and cleaner air.

Specifically, I recommend that DEQ allocate the maximum allowable amount (15%) of the funds for electric vehicle charging infrastructure and installations. And I encourage DEQ to prioritize electric vehicles and buses for replacement whenever possible with the other 85% of the settlement funds. Doing so will maximize the local economic impact and the reduction of air pollution.

I encourage you to not use the funding for natural gas, propane or diesel vehicles. Further dependence on fossil fuels means more pollution. Only a transition to electric vehicles and investment in EV infrastructure will put us on the road to a 100% clean transportation sector in North Carolina.

Sincerely,

Judy Smith
2558 Empie Dr.
Leland, NC 28451
jsnorkel23@gmail.com
(910) 228-5056

This message was sent by KnowWho, as a service provider only, on behalf of the individual noted in the sender information.

From: John Wiles (jwiles3rd@gmail.com) Sent You a Personal Message
To: [daq.NC_VWGrants](#)
Subject: [External] Use Volkswagen funds to electrify NC transportation
Date: Wednesday, December 20, 2017 4:50:10 PM

CAUTION: External email. Do not click links or open attachments unless verified. Send all suspicious email as an attachment to report.spam@nc.gov.

Dear Division of Air Quality,

I am writing to urge DEQ to wisely invest the \$92 million in Volkswagen settlement funds in electric vehicles and infrastructure. Taking advantage of these funds to jumpstart the electrification of North Carolina's transportation sector will mean less money sent out of state for petroleum, more in-state jobs, and cleaner air.

Specifically, I recommend that DEQ allocate the maximum allowable amount (15%) of the funds for electric vehicle charging infrastructure and installations. And I encourage DEQ to prioritize electric vehicles and buses for replacement whenever possible with the other 85% of the settlement funds. Doing so will maximize the local economic impact and the reduction of air pollution.

I encourage you to not use the funding for natural gas, propane or diesel vehicles. Further dependence on fossil fuels means more pollution. Only a transition to electric vehicles and investment in EV infrastructure will put us on the road to a 100% clean transportation sector in North Carolina.

Sincerely,

John Wiles
5205 Langford Ter
Durham, NC 27713
jwiles3rd@gmail.com
(901) 301-8894

This message was sent by KnowWho, as a service provider only, on behalf of the individual noted in the sender information.

From: Jim Dixon (jedixonx3@cox.net) Sent You a Personal Message
To: [daq.NC_VWGrants](#)
Subject: [External] Use Volkswagen funds to electrify NC transportation
Date: Wednesday, December 20, 2017 4:30:26 PM

CAUTION: External email. Do not click links or open attachments unless verified. Send all suspicious email as an attachment to report.spam@nc.gov.

Dear Division of Air Quality,

I am writing to urge DEQ to wisely invest the \$92 million in Volkswagen settlement funds in electric vehicles and infrastructure. Taking advantage of these funds to jumpstart the electrification of North Carolina's transportation sector will mean less money sent out of state for petroleum, more in-state jobs, and cleaner air.

Specifically, I recommend that DEQ allocate the maximum allowable amount (15%) of the funds for electric vehicle charging infrastructure and installations. And I encourage DEQ to prioritize electric vehicles and buses for replacement whenever possible with the other 85% of the settlement funds. Doing so will maximize the local economic impact and the reduction of air pollution.

I encourage you to not use the funding for natural gas, propane or diesel vehicles. Further dependence on fossil fuels means more pollution. Only a transition to electric vehicles and investment in EV infrastructure will put us on the road to a 100% clean transportation sector in North Carolina.

Sincerely,

Jim Dixon
6745 peach tree cir
Roanoke, VA 24018
jedixonx3@cox.net
(540) 266-7674

This message was sent by KnowWho, as a service provider only, on behalf of the individual noted in the sender information.

From: Stephen Weissman (sweissman4@gmail.com) Sent You a Personal Message
To: [daq.NC_VWGrants](#)
Subject: [External] Use Volkswagen funds to electrify NC transportation
Date: Wednesday, December 20, 2017 4:11:53 PM

CAUTION: External email. Do not click links or open attachments unless verified. Send all suspicious email as an attachment to report.spam@nc.gov.

Dear Division of Air Quality,

I am writing to urge DEQ to wisely invest the \$92 million in Volkswagen settlement funds in electric vehicles and infrastructure. Taking advantage of these funds to jumpstart the electrification of North Carolina's transportation sector will mean less money sent out of state for petroleum, more in-state jobs, and cleaner air.

Specifically, I recommend that DEQ allocate the maximum allowable amount (15%) of the funds for electric vehicle charging infrastructure and installations. And I encourage DEQ to prioritize electric vehicles and buses for replacement whenever possible with the other 85% of the settlement funds. Doing so will maximize the local economic impact and the reduction of air pollution.

I encourage you to not use the funding for natural gas, propane or diesel vehicles. Further dependence on fossil fuels means more pollution. Only a transition to electric vehicles and investment in EV infrastructure will put us on the road to a 100% clean transportation sector in North Carolina.

Sincerely,

Stephen Weissman
434 Gorman Bridge Rd
Asheville, NC 28806
sweissman4@gmail.com
(828) 255-5602

This message was sent by KnowWho, as a service provider only, on behalf of the individual noted in the sender information.

From: Eric Schweitzer (spinweb1@yahoo.com) Sent You a Personal Message
To: [daq.NC_VWGrants](#)
Subject: [External] Use Volkswagen funds to electrify NC transportation
Date: Wednesday, December 20, 2017 4:10:02 PM

CAUTION: External email. Do not click links or open attachments unless verified. Send all suspicious email as an attachment to report.spam@nc.gov.

Dear Division of Air Quality,

I am writing to urge DEQ to wisely invest the \$92 million in Volkswagen settlement funds in electric vehicles and infrastructure. Taking advantage of these funds to jumpstart the electrification of North Carolina's transportation sector will mean less money sent out of state for petroleum, more in-state jobs, and cleaner air.

Specifically, I recommend that DEQ allocate the maximum allowable amount (15%) of the funds for electric vehicle charging infrastructure and installations. And I encourage DEQ to prioritize electric vehicles and buses for replacement whenever possible with the other 85% of the settlement funds. Doing so will maximize the local economic impact and the reduction of air pollution.

I encourage you to not use the funding for natural gas, propane or diesel vehicles. Further dependence on fossil fuels means more pollution. Only a transition to electric vehicles and investment in EV infrastructure will put us on the road to a 100% clean transportation sector in North Carolina.

Sincerely,

Eric Schweitzer
6019 Sentinel Dr
Raleigh, NC 27609
spinweb1@yahoo.com
(919) 872-6071

This message was sent by KnowWho, as a service provider only, on behalf of the individual noted in the sender information.

From: Win Southworth (southworth@hotmail.com) Sent You a Personal Message
To: daq.NC_VWGrants
Subject: [External] Using Volkswagen funds to electrify NC transportation is the positive action to take
Date: Wednesday, December 20, 2017 3:21:55 PM

CAUTION: External email. Do not click links or open attachments unless verified. Send all suspicious email as an attachment to report.spam@nc.gov.

Dear Division of Air Quality,

I ask DEQ to wisely invest the \$92 million in Volkswagen settlement funds in electric vehicles and infrastructure. Taking advantage of these funds to jump-start the electrification of North Carolina's transportation sector will mean less money sent out of state for petroleum, more in-state jobs, and cleaner air.

It makes so much sense for DEQ to allocate the maximum allowable amount (15%) of the funds for electric vehicle charging infrastructure and installations. And I encourage DEQ to prioritize electric vehicles and buses for replacement whenever possible with the other 85% of the settlement funds. Doing so will maximize the local economic impact and the reduction of air pollution.

Please do not use the funding for natural gas, propane or diesel vehicles. Further dependence on fossil fuels means more pollution. Only a transition to electric vehicles and investment in EV infrastructure will put us on the road to a 100% clean transportation sector in North Carolina and be a particularly significant job creator.

Sincerely,

Win Southworth
701 Warren Wilson Rd.
Swannanoa, NC 28778
southworth@hotmail.com
(828) 989-2993

This message was sent by KnowWho, as a service provider only, on behalf of the individual noted in the sender information.

From: Wesley Wallace (wes.wallace@icloud.com) Sent You a Personal Message
To: [daq.NC_VWGrants](#)
Subject: [External] Use Volkswagen funds to electrify NC transportation
Date: Wednesday, December 20, 2017 3:14:28 PM

CAUTION: External email. Do not click links or open attachments unless verified. Send all suspicious email as an attachment to report.spam@nc.gov.

Dear Division of Air Quality,

I am writing to urge DEQ to wisely invest the \$92 million in Volkswagen settlement funds in electric vehicles and infrastructure. Taking advantage of these funds to jumpstart the electrification of North Carolina's transportation sector will mean less money sent out of state for petroleum, more in-state jobs, and cleaner air.

Specifically, I recommend that DEQ allocate the maximum allowable amount (15%) of the funds for electric vehicle charging infrastructure and installations. And I encourage DEQ to prioritize electric vehicles and buses for replacement whenever possible with the other 85% of the settlement funds. Doing so will maximize the local economic impact and the reduction of air pollution.

I encourage you to not use the funding for natural gas, propane or diesel vehicles. Further dependence on fossil fuels means more pollution. Only a transition to electric vehicles and investment in EV infrastructure will put us on the road to a 100% clean transportation sector in North Carolina.

Sincerely,

Wesley Wallace
411 Overland Drive
Chapel Hill, NC 27517
wes.wallace@icloud.com
(919) 259-2659

This message was sent by KnowWho, as a service provider only, on behalf of the individual noted in the sender information.

From: Larissa Bowman (mvp@bellsouth.net) Sent You a Personal Message
To: daq.NC_VWGrants
Subject: [External] Let's Use Volkswagen funds to electrify NC transportation!!!
Date: Wednesday, December 20, 2017 3:14:27 PM

CAUTION: External email. Do not click links or open attachments unless verified. Send all suspicious email as an attachment to report.spam@nc.gov.

Dear Division of Air Quality,

I am writing to urge DEQ to wisely invest the \$92 million in Volkswagen settlement funds in electric vehicles and infrastructure. Taking advantage of these funds to jumpstart the electrification of North Carolina's transportation sector will mean less money sent out of state for petroleum, more in-state jobs, and cleaner air.

Specifically, I recommend that DEQ allocate the maximum allowable amount (15%) of the funds for electric vehicle charging infrastructure and installations. And I encourage DEQ to prioritize electric vehicles and buses for replacement whenever possible with the other 85% of the settlement funds. Doing so will maximize the local economic impact and the reduction of air pollution.

I encourage you to not use the funding for natural gas, propane or diesel vehicles. Further dependence on fossil fuels means more pollution. Only a transition to electric vehicles and investment in EV infrastructure will put us on the road to a 100% clean transportation sector in North Carolina.

Sincerely,

Larissa Bowman
677 Brevard Road
Asheville, NC 28806
mvp@bellsouth.net
(828) 670-8327

This message was sent by KnowWho, as a service provider only, on behalf of the individual noted in the sender information.

From: Lawrence East (rstyeast@aol.com) Sent You a Personal Message
To: [daq.NC_VWGrants](#)
Subject: [External] Use Volkswagen funds to electrify NC transportation
Date: Wednesday, December 20, 2017 3:13:28 PM

CAUTION: External email. Do not click links or open attachments unless verified. Send all suspicious email as an attachment to report.spam@nc.gov.

Dear Division of Air Quality,

I am writing to urge DEQ to wisely invest the \$92 million in Volkswagen settlement funds in electric vehicles and infrastructure. Taking advantage of these funds to jumpstart the electrification of North Carolina's transportation sector will mean less money sent out of state for petroleum, more in-state jobs, and cleaner air.

Specifically, I recommend that DEQ allocate the maximum allowable amount (15%) of the funds for electric vehicle charging infrastructure and installations. And I encourage DEQ to prioritize electric vehicles and buses for replacement whenever possible with the other 85% of the settlement funds. Doing so will maximize the local economic impact and the reduction of air pollution.

I encourage you to not use the funding for natural gas, propane or diesel vehicles. Further dependence on fossil fuels means more pollution. Only a transition to electric vehicles and investment in EV infrastructure will put us on the road to a 100% clean transportation sector in North Carolina.

Sincerely,

Lawrence East
316 Richlands Ave, Apt. 5
Jacksonville, NC 28540
rstyeast@aol.com
(999) 999-9999

This message was sent by KnowWho, as a service provider only, on behalf of the individual noted in the sender information.

From: Robert Belknap (rebelknap@sms.edu) Sent You a Personal Message
To: [daq.NC_VWGrants](#)
Subject: [External] Use Volkswagen funds to electrify NC transportation
Date: Wednesday, December 20, 2017 3:12:04 PM

CAUTION: External email. Do not click links or open attachments unless verified. Send all suspicious email as an attachment to report.spam@nc.gov.

Dear Division of Air Quality,

I am writing to urge DEQ to wisely invest the \$92 million in Volkswagen settlement funds in electric vehicles and infrastructure. Taking advantage of these funds to jumpstart the electrification of North Carolina's transportation sector will mean less money sent out of state for petroleum, more in-state jobs, and cleaner air.

Specifically, I recommend that DEQ allocate the maximum allowable amount (15%) of the funds for electric vehicle charging infrastructure and installations. And I encourage DEQ to prioritize electric vehicles and buses for replacement whenever possible with the other 85% of the settlement funds. Doing so will maximize the local economic impact and the reduction of air pollution.

I encourage you to not use the funding for natural gas, propane or diesel vehicles. Further dependence on fossil fuels means more pollution. Only a transition to electric vehicles and investment in EV infrastructure will put us on the road to a 100% clean transportation sector in North Carolina.

Sincerely,

Robert Belknap
900 Hillsborough Street
Raleigh, NC 27603
rebelknap@sms.edu
(919) 424-3654

This message was sent by KnowWho, as a service provider only, on behalf of the individual noted in the sender information.

From: Barry Alexander (bjalex47@gmail.com) Sent You a Personal Message
To: daq.NC_VWGrants
Subject: [External] Use Volkswagen funds to electrify NC transportation
Date: Wednesday, December 20, 2017 3:10:46 PM

CAUTION: External email. Do not click links or open attachments unless verified. Send all suspicious email as an attachment to report.spam@nc.gov.

Dear Division of Air Quality,

I am writing to urge DEQ to wisely invest the \$92 million in Volkswagen settlement funds in electric vehicles and infrastructure. Taking advantage of these funds to jumpstart the electrification of North Carolina's transportation sector will mean less money sent out of state for petroleum, more in-state jobs, and cleaner air.

Specifically, I recommend that DEQ allocate the maximum allowable amount (15%) of the funds for electric vehicle charging infrastructure and installations. And I encourage DEQ to prioritize electric vehicles and buses for replacement whenever possible with the other 85% of the settlement funds. Doing so will maximize the local economic impact and the reduction of air pollution.

I encourage you to not use the funding for natural gas, propane or diesel vehicles. Further dependence on fossil fuels means more pollution. Only a transition to electric vehicles and investment in EV infrastructure will put us on the road to a 100% clean transportation sector in North Carolina.

Sincerely,

Barry Alexander
2 Jacobs Way
Greensboro, NC 27455
bjalex47@gmail.com
(336) 317-4273

This message was sent by KnowWho, as a service provider only, on behalf of the individual noted in the sender information.

From: Ronald Clayton (se-larvae@hotmail.com) Sent You a Personal Message
To: [daq.NC_VWGrants](#)
Subject: [External] Use Volkswagen funds to electrify NC transportation
Date: Wednesday, December 20, 2017 2:53:55 PM

CAUTION: External email. Do not click links or open attachments unless verified. Send all suspicious email as an attachment to report.spam@nc.gov.

Dear Division of Air Quality,

I urge DEQ to wisely invest the \$92 million in Volkswagen settlement funds in electric vehicles and infrastructure.

Taking advantage of these funds to jumpstart the electrification of North Carolina's transportation sector will mean less money sent out of state for petroleum, more in-state jobs, and cleaner air.

I recommend that DEQ allocate the maximum allowable amount (15%) of the funds for electric vehicle charging infrastructure and installations.

And ... I encourage DEQ to prioritize electric vehicles and buses for replacement whenever possible with the other 85% of the settlement funds. Doing so will maximize the local economic impact and the reduction of air pollution.

Please DO NOT use the funding for natural gas, propane or diesel vehicles. * Further dependence on fossil fuels means more pollution.

Only a transition to electric vehicles and investment in EV infrastructure will put us on the road to a 100% clean transportation sector in North Carolina.

Sincerely,

Ronald Clayton
10860 OLD US HIGHWAY 70
COVE CITY, NC 28523
se-larvae@hotmail.com
(336) 460-0019

This message was sent by KnowWho, as a service provider only, on behalf of the individual noted in the sender information.

From: Deborah Milkowski (debmilkocal@twc.com) Sent You a Personal Message
To: [daq.NC_VWGrants](#)
Subject: [External] Use Volkswagen funds to electrify NC transportation
Date: Wednesday, December 20, 2017 2:51:59 PM

CAUTION: External email. Do not click links or open attachments unless verified. Send all suspicious email as an attachment to report.spam@nc.gov.

Dear Division of Air Quality,

I am writing to urge DEQ to wisely invest the \$92 million in Volkswagen settlement funds in electric vehicles and infrastructure. Taking advantage of these funds to jumpstart the electrification of North Carolina's transportation sector will mean less money sent out of state for petroleum, more in-state jobs, and cleaner air.

Specifically, I recommend that DEQ allocate the maximum allowable amount (15%) of the funds for electric vehicle charging infrastructure and installations. And I encourage DEQ to prioritize electric vehicles and buses for replacement whenever possible with the other 85% of the settlement funds. Doing so will maximize the local economic impact and the reduction of air pollution.

I encourage you to not use the funding for natural gas, propane or diesel vehicles. Further dependence on fossil fuels means more pollution. Only a transition to electric vehicles and investment in EV infrastructure will put us on the road to a 100% clean transportation sector in North Carolina.

Sincerely,

Deborah Milkowski
2119 Bay Colony Lane
Wilmington, NC 28405
debmilkocal@twc.com
(252) 571-4330

This message was sent by KnowWho, as a service provider only, on behalf of the individual noted in the sender information.

From: Lawrence Turk, RN (butch@wildrockies.org) Sent You a Personal Message
To: daq.NC_VWGrants
Subject: [External] Use Volkswagen funds to electrify NC transportation
Date: Wednesday, December 20, 2017 2:46:44 PM

CAUTION: External email. Do not click links or open attachments unless verified. Send all suspicious email as an attachment to report.spam@nc.gov.

Dear Division of Air Quality,

I am writing to urge DEQ to wisely invest the \$92 million in Volkswagen settlement funds in electric vehicles and infrastructure. Taking advantage of these funds to jumpstart the electrification of North Carolina's transportation sector will mean less money sent out of state for petroleum, more in-state jobs, and cleaner air.

Specifically, I recommend that DEQ allocate the maximum allowable amount (15%) of the funds for electric vehicle charging infrastructure and installations. And I encourage DEQ to prioritize electric vehicles and buses for replacement whenever possible with the other 85% of the settlement funds. Doing so will maximize the local economic impact and the reduction of air pollution.

I encourage you to not use the funding for natural gas, propane or diesel vehicles. Further dependence on fossil fuels means more pollution. Only a transition to electric vehicles and investment in EV infrastructure will put us on the road to a 100% clean transportation sector in North Carolina.

Sincerely,

Lawrence Turk, RN
POB 203
Hendersonville, NC 28793
butch@wildrockies.org
(555) 555-5555

This message was sent by KnowWho, as a service provider only, on behalf of the individual noted in the sender information.

From: Jane Chapman (turtlegirljane@hotmail.com) Sent You a Personal Message
To: [daq.NC_VWGrants](#)
Subject: [External] Use Volkswagen funds to electrify NC transportation
Date: Wednesday, December 20, 2017 2:40:14 PM

CAUTION: External email. Do not click links or open attachments unless verified. Send all suspicious email as an attachment to report.spam@nc.gov.

Dear Division of Air Quality,

I am writing to urge DEQ to wisely invest the \$92 million in Volkswagen settlement funds in electric vehicles and infrastructure. Taking advantage of these funds to jumpstart the electrification of North Carolina's transportation sector will mean less money sent out of state for petroleum, more in-state jobs, and cleaner air.

Specifically, I recommend that DEQ allocate the maximum allowable amount (15%) of the funds for electric vehicle charging infrastructure and installations. And I encourage DEQ to prioritize electric vehicles and buses for replacement whenever possible with the other 85% of the settlement funds. Doing so will maximize the local economic impact and the reduction of air pollution.

I encourage you to not use the funding for natural gas, propane or diesel vehicles. Further dependence on fossil fuels means more pollution. Only a transition to electric vehicles and investment in EV infrastructure will put us on the road to a 100% clean transportation sector in North Carolina.

Sincerely,

Jane Chapman
918 Shellbrook Court
Raleigh, NC 27609
turtlegirljane@hotmail.com
(919) 571-7169

This message was sent by KnowWho, as a service provider only, on behalf of the individual noted in the sender information.

From: William Taylor (nealtaylor405@gmail.com) Sent You a Personal Message
To: [daq.NC_VWGrants](#)
Subject: [External] Use Volkswagen funds to electrify NC transportation
Date: Wednesday, December 20, 2017 2:38:17 PM

CAUTION: External email. Do not click links or open attachments unless verified. Send all suspicious email as an attachment to report.spam@nc.gov.

Dear Division of Air Quality,

I am writing to urge DEQ to wisely invest the \$92 million in Volkswagen settlement funds in electric vehicles and infrastructure. Taking advantage of these funds to jumpstart the electrification of North Carolina's transportation sector will mean less money sent out of state for petroleum, more in-state jobs, and cleaner air.

Specifically, I recommend that DEQ allocate the maximum allowable amount (15%) of the funds for electric vehicle charging infrastructure and installations. And I encourage DEQ to prioritize electric vehicles and buses for replacement whenever possible with the other 85% of the settlement funds. Doing so will maximize the local economic impact and the reduction of air pollution.

I encourage you to not use the funding for natural gas, propane or diesel vehicles. Further dependence on fossil fuels means more pollution. Only a transition to electric vehicles and investment in EV infrastructure will put us on the road to a 100% clean transportation sector in North Carolina.

Sincerely,

William Taylor
2012 Creecy Ave
Wilmington, NC 28403
nealtaylor405@gmail.com
(910) 470-1030

This message was sent by KnowWho, as a service provider only, on behalf of the individual noted in the sender information.

From: Akila Mosier (soulhunter379@gmail.com) Sent You a Personal Message
To: [daq.NC_VWGrants](#)
Subject: [External] Use Volkswagen funds to electrify NC transportation
Date: Wednesday, December 20, 2017 2:21:25 PM

CAUTION: External email. Do not click links or open attachments unless verified. Send all suspicious email as an attachment to report.spam@nc.gov.

Dear Division of Air Quality,

I am writing to urge DEQ to wisely invest the \$92 million in Volkswagen settlement funds in electric vehicles and infrastructure. Taking advantage of these funds to jumpstart the electrification of North Carolina's transportation sector will mean less money sent out of state for petroleum, more in-state jobs, and cleaner air.

Specifically, I recommend that DEQ allocate the maximum allowable amount (15%) of the funds for electric vehicle charging infrastructure and installations. And I encourage DEQ to prioritize electric vehicles and buses for replacement whenever possible with the other 85% of the settlement funds. Doing so will maximize the local economic impact and the reduction of air pollution.

I encourage you to not use the funding for natural gas, propane or diesel vehicles. Further dependence on fossil fuels means more pollution. Only a transition to electric vehicles and investment in EV infrastructure will put us on the road to a 100% clean transportation sector in North Carolina.

Sincerely,

Akila Mosier
365 Huffmantown Road
Richlands, NC 28574
soulhunter379@gmail.com
(910) 545-7842

This message was sent by KnowWho, as a service provider only, on behalf of the individual noted in the sender information.

From: Virgil Carmichael (virgilcarmichael@gmail.com) Sent You a Personal Message
To: [daq.NC_VWGrants](#)
Subject: [External] Use Volkswagen funds to electrify NC transportation
Date: Wednesday, December 20, 2017 2:18:49 PM

CAUTION: External email. Do not click links or open attachments unless verified. Send all suspicious email as an attachment to report.spam@nc.gov.

Dear Division of Air Quality,

I am writing to urge DEQ to wisely invest the \$92 million in Volkswagen settlement funds in electric vehicles and infrastructure. Taking advantage of these funds to jumpstart the electrification of North Carolina's transportation sector will mean less money sent out of state for petroleum, more in-state jobs, and cleaner air.

Specifically, I recommend that DEQ allocate the maximum allowable amount (15%) of the funds for electric vehicle charging infrastructure and installations. And I encourage DEQ to prioritize electric vehicles and buses for replacement whenever possible with the other 85% of the settlement funds. Doing so will maximize the local economic impact and the reduction of air pollution.

I encourage you to not use the funding for natural gas, propane or diesel vehicles. Further dependence on fossil fuels means more pollution. Only a transition to electric vehicles and investment in EV infrastructure will put us on the road to a 100% clean transportation sector in North Carolina.

Sincerely,

Virgil Carmichael
4403 Angelus Circle
Asheville, NC 28805
virgilcarmichael@gmail.com
(828) 242-7709

This message was sent by KnowWho, as a service provider only, on behalf of the individual noted in the sender information.

From: Marilyn Collins (tukki222@me.com) Sent You a Personal Message
To: [daq.NC_VWGrants](#)
Subject: [External] Use Volkswagen funds to electrify NC transportation
Date: Wednesday, December 20, 2017 2:13:08 PM

CAUTION: External email. Do not click links or open attachments unless verified. Send all suspicious email as an attachment to report.spam@nc.gov.

Dear Division of Air Quality,

I am writing to urge DEQ to wisely invest the \$92 million in Volkswagen settlement funds in electric vehicles and infrastructure. Taking advantage of these funds to jumpstart the electrification of North Carolina's transportation sector will mean less money sent out of state for petroleum, more in-state jobs, and cleaner air.

Specifically, I recommend that DEQ allocate the maximum allowable amount (15%) of the funds for electric vehicle charging infrastructure and installations. And I encourage DEQ to prioritize electric vehicles and buses for replacement whenever possible with the other 85% of the settlement funds. Doing so will maximize the local economic impact and the reduction of air pollution.

I encourage you to not use the funding for natural gas, propane or diesel vehicles. Further dependence on fossil fuels means more pollution. Only a transition to electric vehicles and investment in EV infrastructure will put us on the road to a 100% clean transportation sector in North Carolina.

Sincerely,

Marilyn Collins
6040 Cedar Ridge Drive
Wilmington, NC 28405
tukki222@me.com
(910) 547-1130

This message was sent by KnowWho, as a service provider only, on behalf of the individual noted in the sender information.

From: Eli Celli (elicelli@att.net) Sent You a Personal Message
To: [daq.NC_VWGrants](#)
Subject: [External] Use Volkswagen funds to electrify NC transportation
Date: Wednesday, December 20, 2017 2:10:29 PM

CAUTION: External email. Do not click links or open attachments unless verified. Send all suspicious email as an attachment to report.spam@nc.gov.

Dear Division of Air Quality,

I am writing to urge DEQ to wisely invest the \$92 million in Volkswagen settlement funds in electric vehicles and infrastructure. Taking advantage of these funds to jumpstart the electrification of North Carolina's transportation sector will mean less money sent out of state for petroleum, more in-state jobs, and cleaner air.

Specifically, I recommend that DEQ allocate the maximum allowable amount (15%) of the funds for electric vehicle charging infrastructure and installations. And I encourage DEQ to prioritize electric vehicles and buses for replacement whenever possible with the other 85% of the settlement funds. Doing so will maximize the local economic impact and the reduction of air pollution.

I encourage you to not use the funding for natural gas, propane or diesel vehicles. Further dependence on fossil fuels means more pollution. Only a transition to electric vehicles and investment in EV infrastructure will put us on the road to a 100% clean transportation sector in North Carolina.

Sincerely,

Eli Celli
407 Legends Way
Chapel Hill, NC 27516
elicelli@att.net
(919) 546-4109

This message was sent by KnowWho, as a service provider only, on behalf of the individual noted in the sender information.

From: Michael Moore (grizzlynt@gmail.com) Sent You a Personal Message
To: daq.NC_VWGrants
Subject: [External] Use Volkswagen funds to electrify NC transportation
Date: Wednesday, December 20, 2017 2:09:47 PM

CAUTION: External email. Do not click links or open attachments unless verified. Send all suspicious email as an attachment to report.spam@nc.gov.

Dear Division of Air Quality,

I am writing to urge DEQ to wisely invest the \$92 million in Volkswagen settlement funds in electric vehicles and infrastructure. Taking advantage of these funds to jumpstart the electrification of North Carolina's transportation sector will mean less money sent out of state for petroleum, more in-state jobs, and cleaner air.

Specifically, I recommend that DEQ allocate the maximum allowable amount (15%) of the funds for electric vehicle charging infrastructure and installations. And I encourage DEQ to prioritize electric vehicles and buses for replacement whenever possible with the other 85% of the settlement funds. Doing so will maximize the local economic impact and the reduction of air pollution.

I encourage you to not use the funding for natural gas, propane or diesel vehicles. Further dependence on fossil fuels means more pollution. Only a transition to electric vehicles and investment in EV infrastructure will put us on the road to a 100% clean transportation sector in North Carolina.

Sincerely,

Michael Moore
107 Hobson Place
Louisburg, NC 27549
grizzlynt@gmail.com
(919) 554-0930

This message was sent by KnowWho, as a service provider only, on behalf of the individual noted in the sender information.

From: john mcdermott (john@bolafurniture.com) Sent You a Personal Message
To: [daq.NC_VWGrants](#)
Subject: [External] Use Volkswagen funds to electrify NC transportation
Date: Wednesday, December 20, 2017 2:07:46 PM

CAUTION: External email. Do not click links or open attachments unless verified. Send all suspicious email as an attachment to report.spam@nc.gov.

Dear Division of Air Quality,

I am writing to urge DEQ to wisely invest the \$92 million in Volkswagen settlement funds in electric vehicles and infrastructure. Taking advantage of these funds to jumpstart the electrification of North Carolina's transportation sector will mean less money sent out of state for petroleum, more in-state jobs, and cleaner air.

Specifically, I recommend that DEQ allocate the maximum allowable amount (15%) of the funds for electric vehicle charging infrastructure and installations. And I encourage DEQ to prioritize electric vehicles and buses for replacement whenever possible with the other 85% of the settlement funds. Doing so will maximize the local economic impact and the reduction of air pollution.

I encourage you to not use the funding for natural gas, propane or diesel vehicles. Further dependence on fossil fuels means more pollution. Only a transition to electric vehicles and investment in EV infrastructure will put us on the road to a 100% clean transportation sector in North Carolina.

Sincerely,

john mcdermott
42 merrills cove rd
asheville, NC 28803
john@bolafurniture.com
(828) 681-0851

This message was sent by KnowWho, as a service provider only, on behalf of the individual noted in the sender information.

From: Susanna Winters (sbwinter1@bellsouth.net) Sent You a Personal Message
To: [daq.NC_VWGrants](#)
Subject: [External] Use Volkswagen funds to electrify NC transportation
Date: Wednesday, December 20, 2017 2:01:26 PM

CAUTION: External email. Do not click links or open attachments unless verified. Send all suspicious email as an attachment to report.spam@nc.gov.

Dear Division of Air Quality,

I am writing to urge DEQ to wisely invest the \$92 million in Volkswagen settlement funds in electric vehicles and infrastructure. Taking advantage of these funds to jumpstart the electrification of North Carolina's transportation sector will mean less money sent out of state for petroleum, more in-state jobs, and cleaner air.

Specifically, I recommend that DEQ allocate the maximum allowable amount (15%) of the funds for electric vehicle charging infrastructure and installations. And I encourage DEQ to prioritize electric vehicles and buses for replacement whenever possible with the other 85% of the settlement funds. Doing so will maximize the local economic impact and the reduction of air pollution.

I encourage you to not use the funding for natural gas, propane or diesel vehicles. Further dependence on fossil fuels means more pollution. Only a transition to electric vehicles and investment in EV infrastructure will put us on the road to a 100% clean transportation sector in North Carolina.

Sincerely,

Susanna Winters
5664 Hamstead Crossing
Raleigh, NC 27612
sbwinter1@bellsouth.net
(919) 782-2199

This message was sent by KnowWho, as a service provider only, on behalf of the individual noted in the sender information.

From: RONALD DE SHON (deshon37@yahoo.com) Sent You a Personal Message
To: [daq.NC_VWGrants](#)
Subject: [External] Use Volkswagen funds to electrify NC transportation
Date: Wednesday, December 20, 2017 1:56:07 PM

CAUTION: External email. Do not click links or open attachments unless verified. Send all suspicious email as an attachment to report.spam@nc.gov.

Dear Division of Air Quality,

I am writing to urge DEQ to wisely invest the \$92 million in Volkswagen settlement funds in electric vehicles and infrastructure. Taking advantage of these funds to jumpstart the electrification of North Carolina's transportation sector will mean less money sent out of state for petroleum, more in-state jobs, and cleaner air.

Specifically, I recommend that DEQ allocate the maximum allowable amount (15%) of the funds for electric vehicle charging infrastructure and installations. And I encourage DEQ to prioritize electric vehicles and buses for replacement whenever possible with the other 85% of the settlement funds. Doing so will maximize the local economic impact and the reduction of air pollution.

I encourage you to not use the funding for natural gas, propane or diesel vehicles. Further dependence on fossil fuels means more pollution. Only a transition to electric vehicles and investment in EV infrastructure will put us on the road to a 100% clean transportation sector in North Carolina.

Sincerely,

RONALD DE SHON
126 BASSWOOD TER
WILKESBORO, NC 28697
deshon37@yahoo.com
(434) 996-1116

This message was sent by KnowWho, as a service provider only, on behalf of the individual noted in the sender information.

From: Linda Gillette (lgillette@netsync.net) Sent You a Personal Message
To: [daq.NC_VWGrants](#)
Subject: [External] Use Volkswagen funds to electrify NC transportation
Date: Wednesday, December 20, 2017 1:54:23 PM

CAUTION: External email. Do not click links or open attachments unless verified. Send all suspicious email as an attachment to report.spam@nc.gov.

Dear Division of Air Quality,

I am writing to urge DEQ to wisely invest the \$92 million in Volkswagen settlement funds in electric vehicles and infrastructure. Taking advantage of these funds to jumpstart the electrification of North Carolina's transportation sector will mean less money sent out of state for petroleum, more in-state jobs, and cleaner air.

Specifically, I recommend that DEQ allocate the maximum allowable amount (15%) of the funds for electric vehicle charging infrastructure and installations. And I encourage DEQ to prioritize electric vehicles and buses for replacement whenever possible with the other 85% of the settlement funds. Doing so will maximize the local economic impact and the reduction of air pollution.

I encourage you to not use the funding for natural gas, propane or diesel vehicles. Further dependence on fossil fuels means more pollution. Only a transition to electric vehicles and investment in EV infrastructure will put us on the road to a 100% clean transportation sector in North Carolina.

Sincerely,

Linda Gillette
108 Brentwood Drive
Hendersonville, NC 28739
lgillette@netsync.net
(716) 673-5950

This message was sent by KnowWho, as a service provider only, on behalf of the individual noted in the sender information.

From: JOHN ELMER (jme348@yahoo.com) Sent You a Personal Message
To: [daq.NC_VWGrants](#)
Subject: [External] Use Volkswagen funds to electrify NC transportation
Date: Wednesday, December 20, 2017 1:53:24 PM

CAUTION: External email. Do not click links or open attachments unless verified. Send all suspicious email as an attachment to report.spam@nc.gov.

Dear Division of Air Quality,

I am writing to urge DEQ to wisely invest the \$92 million in Volkswagen settlement funds in electric vehicles and infrastructure. Taking advantage of these funds to jumpstart the electrification of North Carolina's transportation sector will mean less money sent out of state for petroleum, more in-state jobs, and cleaner air.

Specifically, I recommend that DEQ allocate the maximum allowable amount (15%) of the funds for electric vehicle charging infrastructure and installations. And I encourage DEQ to prioritize electric vehicles and buses for replacement whenever possible with the other 85% of the settlement funds. Doing so will maximize the local economic impact and the reduction of air pollution.

I encourage you to not use the funding for natural gas, propane or diesel vehicles. Further dependence on fossil fuels means more pollution. Only a transition to electric vehicles and investment in EV infrastructure will put us on the road to a 100% clean transportation sector in North Carolina.

Sincerely,

JOHN ELMER
1207 DUNBAR CT
WILMINGTON, NC 28405
jme348@yahoo.com
(910) 742-9691

This message was sent by KnowWho, as a service provider only, on behalf of the individual noted in the sender information.

From: Matthew Taylor (matthew.taylor1999@gmail.com) Sent You a Personal Message
To: [daq.NC_VWGrants](#)
Subject: [External] Use Volkswagen funds to electrify NC transportation
Date: Tuesday, December 19, 2017 4:02:31 PM

CAUTION: External email. Do not click links or open attachments unless verified. Send all suspicious email as an attachment to report.spam@nc.gov.

Dear Division of Air Quality,

I am writing to urge DEQ to wisely invest the \$92 million in Volkswagen settlement funds in electric vehicles and infrastructure. Taking advantage of these funds to jumpstart the electrification of North Carolina's transportation sector will mean less money sent out of state for petroleum, more in-state jobs, and cleaner air.

Specifically, I recommend that DEQ allocate the maximum allowable amount (15%) of the funds for electric vehicle charging infrastructure and installations. And I encourage DEQ to prioritize electric vehicles and buses for replacement whenever possible with the other 85% of the settlement funds. Doing so will maximize the local economic impact and the reduction of air pollution.

I encourage you to not use the funding for natural gas, propane or diesel vehicles. Further dependence on fossil fuels means more pollution. Only a transition to electric vehicles and investment in EV infrastructure will put us on the road to a 100% clean transportation sector in North Carolina.

Sincerely,

Matthew Taylor
1710 Overlook Dr
Grapevine, TX 76051
matthew.taylor1999@gmail.com
(517) 376-0540

This message was sent by KnowWho, as a service provider only, on behalf of the individual noted in the sender information.

From: Hal Trufan (htrufan@gmail.com) Sent You a Personal Message
To: [daq.NC_VWGrants](#)
Subject: [External] Use Volkswagen funds to electrify NC transportation
Date: Monday, December 18, 2017 9:26:35 PM

CAUTION: External email. Do not click links or open attachments unless verified. Send all suspicious email as an attachment to report.spam@nc.gov.

Dear Division of Air Quality,

I am writing to urge DEQ to wisely invest the \$92 million in Volkswagen settlement funds in electric vehicles and infrastructure. Taking advantage of these funds to jumpstart the electrification of North Carolina's transportation sector will mean less money sent out of state for petroleum, more in-state jobs, and cleaner air.

Specifically, I recommend that DEQ allocate the maximum allowable amount (15%) of the funds for electric vehicle charging infrastructure and installations. And I encourage DEQ to prioritize electric vehicles and buses for replacement whenever possible with the other 85% of the settlement funds. Doing so will maximize the local economic impact and the reduction of air pollution.

I encourage you to not use the funding for natural gas, propane or diesel vehicles. Further dependence on fossil fuels means more pollution. Only a transition to electric vehicles and investment in EV infrastructure will put us on the road to a 100% clean transportation sector in North Carolina.

Sincerely,

Hal Trufan
1301 Aringill Ln
Matthews, NC 28104
htrufan@gmail.com
(980) 208-6892

This message was sent by KnowWho, as a service provider only, on behalf of the individual noted in the sender information.

From: Vivian Lord (vlord02@gmail.com) Sent You a Personal Message
To: [daq.NC_VWGrants](#)
Subject: [External] Use Volkswagen funds to electrify NC transportation
Date: Monday, December 18, 2017 1:34:36 PM

CAUTION: External email. Do not click links or open attachments unless verified. Send all suspicious email as an attachment to report.spam@nc.gov.

Dear Division of Air Quality,

I am writing to urge DEQ to wisely invest the \$92 million in Volkswagen settlement funds in electric vehicles and infrastructure. Taking advantage of these funds to jumpstart the electrification of North Carolina's transportation sector will mean less money sent out of state for petroleum, more in-state jobs, and cleaner air.

Specifically, I recommend that DEQ allocate the maximum allowable amount (15%) of the funds for electric vehicle charging infrastructure and installations. And I encourage DEQ to prioritize electric vehicles and buses for replacement whenever possible with the other 85% of the settlement funds. Doing so will maximize the local economic impact and the reduction of air pollution.

I encourage you to not use the funding for natural gas, propane or diesel vehicles. Further dependence on fossil fuels means more pollution. Only a transition to electric vehicles and investment in EV infrastructure will put us on the road to a 100% clean transportation sector in North Carolina.

Sincerely,

Vivian Lord
8335 McCarron Way
Charlotte, NC 28215
vlord02@gmail.com
(704) 796-0539

This message was sent by KnowWho, as a service provider only, on behalf of the individual noted in the sender information.

From: Xavier Basurto (xbasurto2002@yahoo.com) Sent You a Personal Message
To: [daq.NC_VWGrants](#)
Subject: [External] Use Volkswagen funds to electrify NC transportation
Date: Sunday, December 17, 2017 8:43:28 AM

CAUTION: External email. Do not click links or open attachments unless verified. Send all suspicious email as an attachment to report.spam@nc.gov.

Dear Division of Air Quality,

I am writing to urge DEQ to wisely invest the \$92 million in Volkswagen settlement funds in electric vehicles and infrastructure. Taking advantage of these funds to jumpstart the electrification of North Carolina's transportation sector will mean less money sent out of state for petroleum, more in-state jobs, and cleaner air.

Specifically, I recommend that DEQ allocate the maximum allowable amount (15%) of the funds for electric vehicle charging infrastructure and installations. And I encourage DEQ to prioritize electric vehicles and buses for replacement whenever possible with the other 85% of the settlement funds. Doing so will maximize the local economic impact and the reduction of air pollution.

I encourage you to not use the funding for natural gas, propane or diesel vehicles. Further dependence on fossil fuels means more pollution. Only a transition to electric vehicles and investment in EV infrastructure will put us on the road to a 100% clean transportation sector in North Carolina.

Sincerely,

Xavier Basurto
243 Gibbs Ct
Beaufort, NC 28516
xbasurto2002@yahoo.com
(252) 728-9900

This message was sent by KnowWho, as a service provider only, on behalf of the individual noted in the sender information.

From: Joanne McGrath (everythingchanges41905@gmail.com) Sent You a Personal Message
To: [daq.NC_VWGrants](#)
Subject: [External] Use Volkswagen funds to electrify NC transportation
Date: Saturday, December 16, 2017 2:07:41 AM

CAUTION: External email. Do not click links or open attachments unless verified. Send all suspicious email as an attachment to report.spam@nc.gov.

Dear Division of Air Quality,

I am writing to urge DEQ to wisely invest the \$92 million in Volkswagen settlement funds in electric vehicles and infrastructure. Taking advantage of these funds to jumpstart the electrification of North Carolina's transportation sector will mean less money sent out of state for petroleum, more in-state jobs, and cleaner air.

Specifically, I recommend that DEQ allocate the maximum allowable amount (15%) of the funds for electric vehicle charging infrastructure and installations. And I encourage DEQ to prioritize electric vehicles and buses for replacement whenever possible with the other 85% of the settlement funds. Doing so will maximize the local economic impact and the reduction of air pollution.

I encourage you to not use the funding for natural gas, propane or diesel vehicles. Further dependence on fossil fuels means more pollution. Only a transition to electric vehicles and investment in EV infrastructure will put us on the road to a 100% clean transportation sector in North Carolina.

Sincerely,

Joanne McGrath
924 Chestnut Cove Rd
Sylva, NC 28779
everythingchanges41905@gmail.com
(828) 631-1572

This message was sent by KnowWho, as a service provider only, on behalf of the individual noted in the sender information.

From: Rajaraman Jayakrishnan (guruguhan@yahoo.com) Sent You a Personal Message
To: [daq.NC_VWGrants](#)
Subject: [External] Use Volkswagen funds to electrify NC transportation
Date: Wednesday, December 13, 2017 1:14:29 PM

CAUTION: External email. Do not click links or open attachments unless verified. Send all suspicious email as an attachment to report.spam@nc.gov.

Dear Division of Air Quality,

I am writing to urge DEQ to wisely invest the \$92 million in Volkswagen settlement funds in electric vehicles and infrastructure. Taking advantage of these funds to jumpstart the electrification of North Carolina's transportation sector will mean less money sent out of state for petroleum, more in-state jobs, and cleaner air.

Specifically, I recommend that DEQ allocate the maximum allowable amount (15%) of the funds for electric vehicle charging infrastructure and installations. And I encourage DEQ to prioritize electric vehicles and buses for replacement whenever possible with the other 85% of the settlement funds. Doing so will maximize the local economic impact and the reduction of air pollution.

I encourage you to not use the funding for natural gas, propane or diesel vehicles. Further dependence on fossil fuels means more pollution. Only a transition to electric vehicles and investment in EV infrastructure will put us on the road to a 100% clean transportation sector in North Carolina.

Sincerely,

Rajaraman Jayakrishnan
525 Hickorywood Blvd
Cary, NC 27519
guruguhan@yahoo.com
(813) 749-0226

This message was sent by KnowWho, as a service provider only, on behalf of the individual noted in the sender information.

From: Peter Tart (petertart57@gmail.com) Sent You a Personal Message
To: [daq.NC_VWGrants](#)
Subject: [External] Use Volkswagen funds to electrify NC transportation
Date: Tuesday, December 12, 2017 1:06:54 PM

CAUTION: External email. Do not click links or open attachments unless verified. Send all suspicious email as an attachment to report.spam@nc.gov.

Dear Division of Air Quality,

I am writing to urge DEQ to wisely invest the \$92 million in Volkswagen settlement funds in electric vehicles and infrastructure. Taking advantage of these funds to jumpstart the electrification of North Carolina's transportation sector will mean less money sent out of state for petroleum, more in-state jobs, and cleaner air.

Specifically, I recommend that DEQ allocate the maximum allowable amount (15%) of the funds for electric vehicle charging infrastructure and installations. And I encourage DEQ to prioritize electric vehicles and buses for replacement whenever possible with the other 85% of the settlement funds. Doing so will maximize the local economic impact and the reduction of air pollution.

I encourage you to not use the funding for natural gas, propane or diesel vehicles. Further dependence on fossil fuels means more pollution. Only a transition to electric vehicles and investment in EV infrastructure will put us on the road to a 100% clean transportation sector in North Carolina.

Sincerely,

Peter Tart
500 Sunrise Summit
Asheville, NC 28804
petertart57@gmail.com
(828) 412-1289

This message was sent by KnowWho, as a service provider only, on behalf of the individual noted in the sender information.

From: judy anderson (jujabeenyo@aol.com) Sent You a Personal Message
To: [daq.NC_VWGrants](#)
Subject: [External] Use Volkswagen funds to electrify NC transportation
Date: Monday, December 11, 2017 8:01:02 PM

CAUTION: External email. Do not click links or open attachments unless verified. Send all suspicious email as an attachment to report.spam@nc.gov.

Dear Division of Air Quality,

I am writing to urge DEQ to wisely invest the \$92 million in Volkswagen settlement funds in electric vehicles and infrastructure. Taking advantage of these funds to jumpstart the electrification of North Carolina's transportation sector will mean less money sent out of state for petroleum, more in-state jobs, and cleaner air.

Specifically, I recommend that DEQ allocate the maximum allowable amount (15%) of the funds for electric vehicle charging infrastructure and installations. And I encourage DEQ to prioritize electric vehicles and buses for replacement whenever possible with the other 85% of the settlement funds. Doing so will maximize the local economic impact and the reduction of air pollution.

I encourage you to not use the funding for natural gas, propane or diesel vehicles. Further dependence on fossil fuels means more pollution. Only a transition to electric vehicles and investment in EV infrastructure will put us on the road to a 100% clean transportation sector in North Carolina.

Sincerely,

judy anderson
3868 fox run
denver, NC 28037
jujabeenyo@aol.com
(704) 483-2667

This message was sent by KnowWho, as a service provider only, on behalf of the individual noted in the sender information.

From: Greg Munster
To: [daq.NC_VWGrants](#)
Subject: [External] Comments on VW funds
Date: Monday, December 11, 2017 4:18:59 PM

CAUTION: External email. Do not click links or open attachments unless verified. Send all suspicious email as an attachment to report.spam@nc.gov.

While more personal use of EV is great, would love to see more commercial use. Could the city set a goal to convert over some % of its fleet (cars, trucks, busses) to Electric?

Greg Munster
Email: gregmunster@att.net
Mobile: 919-491-0101

From: Anna Ladd Coaching
To: daq.NC_VWGrants
Subject: [External] Comments on VW funds
Date: Monday, December 11, 2017 4:17:04 PM

CAUTION: External email. Do not click links or open attachments unless verified. Send all suspicious email as an attachment to report.spam@nc.gov.

I would love to funds used in the following ways:

- *10% of allowable funds should be spent on electric vehicle charging stations.*
- *Additional funds should be used for public transit and school buses in urban areas where improved transit will significantly benefit air quality and quality of life for the residents of NC.*



Anna Ladd Coaching

Co-Active Coach | President ICF RAC

p: (919) 256-3779

a: 410 North Boylan Ave Suite 132, Raleigh, NC 27603

w: Annaladd.com **e:** Anna@annaladd.com



From: Tish Yarborough (tish.yarborough@gmail.com) Sent You a Personal Message
To: [daq.NC_VWGrants](#)
Subject: [External] Use Volkswagen funds to electrify NC transportation
Date: Monday, December 11, 2017 3:39:45 PM

CAUTION: External email. Do not click links or open attachments unless verified. Send all suspicious email as an attachment to report.spam@nc.gov.

Dear Division of Air Quality,

I am writing to urge DEQ to wisely invest the \$92 million in Volkswagen settlement funds in electric vehicles and infrastructure. Taking advantage of these funds to jumpstart the electrification of North Carolina's transportation sector will mean less money sent out of state for petroleum, more in-state jobs, and cleaner air.

Specifically, I recommend that DEQ allocate the maximum allowable amount (15%) of the funds for electric vehicle charging infrastructure and installations. And I encourage DEQ to prioritize electric vehicles and buses for replacement whenever possible with the other 85% of the settlement funds. Doing so will maximize the local economic impact and the reduction of air pollution.

I encourage you to not use the funding for natural gas, propane or diesel vehicles. Further dependence on fossil fuels means more pollution. Only a transition to electric vehicles and investment in EV infrastructure will put us on the road to a 100% clean transportation sector in North Carolina.

Sincerely,

Tish Yarborough
7517 Mason Landing Rd.
Wilmington, NC 28411
tish.yarborough@gmail.com
(910) 686-3712

This message was sent by KnowWho, as a service provider only, on behalf of the individual noted in the sender information.

From: Vincent Quinones (vquin96427@aol.com) Sent You a Personal Message
To: daq.NC_VWGrants
Subject: [External] Use Volkswagen funds to electrify NC transportation
Date: Sunday, December 10, 2017 8:06:08 PM

CAUTION: External email. Do not click links or open attachments unless verified. Send all suspicious email as an attachment to report.spam@nc.gov.

Dear Division of Air Quality,

I am writing to urge DEQ to wisely invest the \$92 million in Volkswagen settlement funds in electric vehicles and infrastructure. Taking advantage of these funds to jumpstart the electrification of North Carolina's transportation sector will mean less money sent out of state for petroleum, more in-state jobs, and cleaner air.

Specifically, I recommend that DEQ allocate the maximum allowable amount (15%) of the funds for electric vehicle charging infrastructure and installations. And I encourage DEQ to prioritize electric vehicles and buses for replacement whenever possible with the other 85% of the settlement funds. Doing so will maximize the local economic impact and the reduction of air pollution.

I encourage you to not use the funding for natural gas, propane or diesel vehicles. Further dependence on fossil fuels means more pollution. Only a transition to electric vehicles and investment in EV infrastructure will put us on the road to a 100% clean transportation sector in North Carolina.

Sincerely,

Vincent Quinones
2405 Alaqua Ct
Matthews, NC 28105
vquin96427@aol.com
(347) 695-7368

This message was sent by KnowWho, as a service provider only, on behalf of the individual noted in the sender information.

From: David Walsh (iamdavewalsh@gmail.com) Sent You a Personal Message
To: [daq.NC_VWGrants](#)
Subject: [External] Use Volkswagen funds to electrify NC transportation
Date: Sunday, December 10, 2017 7:25:33 PM

CAUTION: External email. Do not click links or open attachments unless verified. Send all suspicious email as an attachment to report.spam@nc.gov.

Dear Division of Air Quality,

I am writing to urge DEQ to wisely invest the \$92 million in Volkswagen settlement funds in electric vehicles and infrastructure. Taking advantage of these funds to jumpstart the electrification of North Carolina's transportation sector will mean less money sent out of state for petroleum, more in-state jobs, and cleaner air.

Specifically, I recommend that DEQ allocate the maximum allowable amount (15%) of the funds for electric vehicle charging infrastructure and installations. And I encourage DEQ to prioritize electric vehicles and buses for replacement whenever possible with the other 85% of the settlement funds. Doing so will maximize the local economic impact and the reduction of air pollution.

I encourage you to not use the funding for natural gas, propane or diesel vehicles. Further dependence on fossil fuels means more pollution. Only a transition to electric vehicles and investment in EV infrastructure will put us on the road to a 100% clean transportation sector in North Carolina.

Sincerely,

David Walsh
6925 valley haven drive
charlotte, NC 28211
iamdavewalsh@gmail.com
(704) 364-5104

This message was sent by KnowWho, as a service provider only, on behalf of the individual noted in the sender information.

From: Elaine Weinmann (elainewein@aol.com) Sent You a Personal Message
To: [daq.NC_VWGrants](#)
Subject: [External] Use Volkswagen funds to electrify NC transportation
Date: Sunday, December 10, 2017 2:20:04 PM

CAUTION: External email. Do not click links or open attachments unless verified. Send all suspicious email as an attachment to report.spam@nc.gov.

Dear Division of Air Quality,

I am writing to urge DEQ to wisely invest the \$92 million in Volkswagen settlement funds in electric vehicles and infrastructure. Taking advantage of these funds to jumpstart the electrification of North Carolina's transportation sector will mean less money sent out of state for petroleum, more in-state jobs, and cleaner air.

Specifically, I recommend that DEQ allocate the maximum allowable amount (15%) of the funds for electric vehicle charging infrastructure and installations. And I encourage DEQ to prioritize electric vehicles and buses for replacement whenever possible with the other 85% of the settlement funds. Doing so will maximize the local economic impact and the reduction of air pollution.

I encourage you to not use the funding for natural gas, propane or diesel vehicles. Further dependence on fossil fuels means more pollution. Only a transition to electric vehicles and investment in EV infrastructure will put us on the road to a 100% clean transportation sector in North Carolina.

Sincerely,

Elaine Weinmann
PO Box 18738
asheville, NC 28814
elainewein@aol.com
(828) 772-9300

This message was sent by KnowWho, as a service provider only, on behalf of the individual noted in the sender information.

From: Deborah Gouldin (gouldi.relay@yahoo.com) Sent You a Personal Message
To: daq.NC_VWGrants
Subject: [External] Use Volkswagen funds to electrify NC transportation
Date: Sunday, December 10, 2017 11:04:12 AM

CAUTION: External email. Do not click links or open attachments unless verified. Send all suspicious email as an attachment to report.spam@nc.gov.

Dear Division of Air Quality,

I am writing to urge DEQ to wisely invest the \$92 million in Volkswagen settlement funds in electric vehicles and infrastructure. Taking advantage of these funds to jumpstart the electrification of North Carolina's transportation sector will mean less money sent out of state for petroleum, more in-state jobs, and cleaner air.

Specifically, I recommend that DEQ allocate the maximum allowable amount (15%) of the funds for electric vehicle charging infrastructure and installations. And I encourage DEQ to prioritize electric vehicles and buses for replacement whenever possible with the other 85% of the settlement funds. Doing so will maximize the local economic impact and the reduction of air pollution.

I encourage you to not use the funding for natural gas, propane or diesel vehicles. Further dependence on fossil fuels means more pollution. Only a transition to electric vehicles and investment in EV infrastructure will put us on the road to a 100% clean transportation sector in North Carolina.

Sincerely,

Deborah Gouldin
792 Lake Royale
Louisburg, NC 27549
gouldi.relay@yahoo.com
(843) 283-6267

This message was sent by KnowWho, as a service provider only, on behalf of the individual noted in the sender information.

From: Wanda Huelsman (paigeturner45066@yahoo.com) Sent You a Personal Message
To: [daq.NC_VWGrants](#)
Subject: [External] Use Volkswagen funds to electrify NC transportation
Date: Sunday, December 10, 2017 9:56:20 AM

CAUTION: External email. Do not click links or open attachments unless verified. Send all suspicious email as an attachment to report.spam@nc.gov.

Dear Division of Air Quality,

I am writing to urge DEQ to wisely invest the \$92 million in Volkswagen settlement funds in electric vehicles and infrastructure. Taking advantage of these funds to jumpstart the electrification of North Carolina's transportation sector will mean less money sent out of state for petroleum, more in-state jobs, and cleaner air.

Specifically, I recommend that DEQ allocate the maximum allowable amount (15%) of the funds for electric vehicle charging infrastructure and installations. And I encourage DEQ to prioritize electric vehicles and buses for replacement whenever possible with the other 85% of the settlement funds. Doing so will maximize the local economic impact and the reduction of air pollution.

I encourage you to not use the funding for natural gas, propane or diesel vehicles. Further dependence on fossil fuels means more pollution. Only a transition to electric vehicles and investment in EV infrastructure will put us on the road to a 100% clean transportation sector in North Carolina.

Sincerely,

Wanda Huelsman
109 Foxwood
WILMINGTON, NC 28409
paigeturner45066@yahoo.com
(937) 543-3329

This message was sent by KnowWho, as a service provider only, on behalf of the individual noted in the sender information.

From: Janet Smith (smithgjanet@yahoo.com) Sent You a Personal Message
To: [daq.NC_VWGrants](#)
Subject: [External] Use Volkswagen funds to electrify NC transportation
Date: Sunday, December 10, 2017 7:24:10 AM

CAUTION: External email. Do not click links or open attachments unless verified. Send all suspicious email as an attachment to report.spam@nc.gov.

Dear Division of Air Quality,

I am writing to urge DEQ to wisely invest the \$92 million in Volkswagen settlement funds in electric vehicles and infrastructure. Taking advantage of these funds to jumpstart the electrification of North Carolina's transportation sector will mean less money sent out of state for petroleum, more in-state jobs, and cleaner air.

Specifically, I recommend that DEQ allocate the maximum allowable amount (15%) of the funds for electric vehicle charging infrastructure and installations. And I encourage DEQ to prioritize electric vehicles and buses for replacement whenever possible with the other 85% of the settlement funds. Doing so will maximize the local economic impact and the reduction of air pollution.

I encourage you to not use the funding for natural gas, propane or diesel vehicles. Further dependence on fossil fuels means more pollution. Only a transition to electric vehicles and investment in EV infrastructure will put us on the road to a 100% clean transportation sector in North Carolina.

Sincerely,

Janet Smith
Box 39
Almond, NC 28702
smithgjanet@yahoo.com
(828) 488-1222

This message was sent by KnowWho, as a service provider only, on behalf of the individual noted in the sender information.

From: Michael Burnham (mjburnham@gmail.com) Sent You a Personal Message
To: [daq.NC_VWGrants](#)
Subject: [External] Use Volkswagen funds to electrify NC transportation
Date: Sunday, December 10, 2017 1:34:24 AM

CAUTION: External email. Do not click links or open attachments unless verified. Send all suspicious email as an attachment to report.spam@nc.gov.

Dear Division of Air Quality,

I am writing to urge DEQ to wisely invest the \$92 million in Volkswagen settlement funds in electric vehicles and infrastructure. Taking advantage of these funds to jumpstart the electrification of North Carolina's transportation sector will mean less money sent out of state for petroleum, more in-state jobs, and cleaner air.

Specifically, I recommend that DEQ allocate the maximum allowable amount (15%) of the funds for electric vehicle charging infrastructure and installations. And I encourage DEQ to prioritize electric vehicles and buses for replacement whenever possible with the other 85% of the settlement funds. Doing so will maximize the local economic impact and the reduction of air pollution.

I encourage you to not use the funding for natural gas, propane or diesel vehicles. Further dependence on fossil fuels means more pollution. Only a transition to electric vehicles and investment in EV infrastructure will put us on the road to a 100% clean transportation sector in North Carolina.

Sincerely,

Michael Burnham
2233 Tanners Mill Drive
Durham, NC 27703
mjburnham@gmail.com
(919) 608-4752

This message was sent by KnowWho, as a service provider only, on behalf of the individual noted in the sender information.

From: Sara Sprinkle (s_sprinkle@hotmail.com) Sent You a Personal Message
To: [daq.NC_VWGrants](#)
Subject: [External] Use Volkswagen funds to electrify NC transportation
Date: Saturday, December 09, 2017 8:46:29 PM

CAUTION: External email. Do not click links or open attachments unless verified. Send all suspicious email as an attachment to report.spam@nc.gov.

Dear Division of Air Quality,

I am writing to urge DEQ to wisely invest the \$92 million in Volkswagen settlement funds in electric vehicles and infrastructure. Taking advantage of these funds to jumpstart the electrification of North Carolina's transportation sector will mean less money sent out of state for petroleum, more in-state jobs, and cleaner air.

Specifically, I recommend that DEQ allocate the maximum allowable amount (15%) of the funds for electric vehicle charging infrastructure and installations. And I encourage DEQ to prioritize electric vehicles and buses for replacement whenever possible with the other 85% of the settlement funds. Doing so will maximize the local economic impact and the reduction of air pollution.

I encourage you to not use the funding for natural gas, propane or diesel vehicles. Further dependence on fossil fuels means more pollution. Only a transition to electric vehicles and investment in EV infrastructure will put us on the road to a 100% clean transportation sector in North Carolina.

Sincerely,

Sara Sprinkle
499 Paisley Circle
Pisgah Forest, NC 28768
s_sprinkle@hotmail.com
(828) 884-6515

This message was sent by KnowWho, as a service provider only, on behalf of the individual noted in the sender information.

From: Julian Gordon (jgordon@aggies.ncat.edu) Sent You a Personal Message
To: [daq.NC_VWGrants](#)
Subject: [External] Use Volkswagen funds to electrify NC transportation
Date: Saturday, December 09, 2017 4:17:02 PM

CAUTION: External email. Do not click links or open attachments unless verified. Send all suspicious email as an attachment to report.spam@nc.gov.

Dear Division of Air Quality,

I am writing to urge DEQ to wisely invest the \$92 million in Volkswagen settlement funds in electric vehicles and infrastructure. Taking advantage of these funds to jumpstart the electrification of North Carolina's transportation sector will mean less money sent out of state for petroleum, more in-state jobs, and cleaner air.

Specifically, I recommend that DEQ allocate the maximum allowable amount (15%) of the funds for electric vehicle charging infrastructure and installations. And I encourage DEQ to prioritize electric vehicles and buses for replacement whenever possible with the other 85% of the settlement funds. Doing so will maximize the local economic impact and the reduction of air pollution.

I encourage you to not use the funding for natural gas, propane or diesel vehicles. Further dependence on fossil fuels means more pollution. Only a transition to electric vehicles and investment in EV infrastructure will put us on the road to a 100% clean transportation sector in North Carolina.

Sincerely,

Julian Gordon
911 Flamingo Drive
Atlanta, GA 30311
jgordon@aggies.ncat.edu
(404) 694-1187

This message was sent by KnowWho, as a service provider only, on behalf of the individual noted in the sender information.

From: Eric Fitch (eric.f900@gmail.com) Sent You a Personal Message
To: [daq.NC_VWGrants](#)
Subject: [External] Use Volkswagen funds to electrify NC transportation
Date: Saturday, December 09, 2017 2:54:41 PM

CAUTION: External email. Do not click links or open attachments unless verified. Send all suspicious email as an attachment to report.spam@nc.gov.

Dear Division of Air Quality,

I am writing to urge DEQ to wisely invest the \$92 million in Volkswagen settlement funds in electric vehicles and infrastructure. Taking advantage of these funds to jumpstart the electrification of North Carolina's transportation sector will mean less money sent out of state for petroleum, more in-state jobs, and cleaner air.

Specifically, I recommend that DEQ allocate the maximum allowable amount (15%) of the funds for electric vehicle charging infrastructure and installations. And I encourage DEQ to prioritize electric vehicles and buses for replacement whenever possible with the other 85% of the settlement funds. Doing so will maximize the local economic impact and the reduction of air pollution.

I encourage you to not use the funding for natural gas, propane or diesel vehicles. Further dependence on fossil fuels means more pollution. Only a transition to electric vehicles and investment in EV infrastructure will put us on the road to a 100% clean transportation sector in North Carolina.

Sincerely,

Eric Fitch
1213 Maury Ct.
Raleigh, NC 27615
eric.f900@gmail.com
(919) 830-4673

This message was sent by KnowWho, as a service provider only, on behalf of the individual noted in the sender information.

From: Susan Hooton (susanhooton@msn.com) Sent You a Personal Message
To: [daq.NC_VWGrants](#)
Subject: [External] Use Volkswagen funds to electrify NC transportation
Date: Saturday, December 09, 2017 11:47:56 AM

CAUTION: External email. Do not click links or open attachments unless verified. Send all suspicious email as an attachment to report.spam@nc.gov.

Dear Division of Air Quality,

I am writing to urge DEQ to wisely invest the \$92 million in Volkswagen settlement funds in electric vehicles and infrastructure. Taking advantage of these funds to jumpstart the electrification of North Carolina's transportation sector will mean less money sent out of state for petroleum, more in-state jobs, and cleaner air.

Specifically, I recommend that DEQ allocate the maximum allowable amount (15%) of the funds for electric vehicle charging infrastructure and installations. And I encourage DEQ to prioritize electric vehicles and buses for replacement whenever possible with the other 85% of the settlement funds. Doing so will maximize the local economic impact and the reduction of air pollution.

I encourage you to not use the funding for natural gas, propane or diesel vehicles. Further dependence on fossil fuels means more pollution. Only a transition to electric vehicles and investment in EV infrastructure will put us on the road to a 100% clean transportation sector in North Carolina.

Sincerely,

Susan Hooton
802 Johns Orchard Lane
Wilmington, NC 28411
susanhooton@msn.com
(910) 233-5101

This message was sent by KnowWho, as a service provider only, on behalf of the individual noted in the sender information.

From: Holly Adkisson (hhadkisson@gmail.com) Sent You a Personal Message
To: [daq.NC_VWGrants](#)
Subject: [External] Use Volkswagen funds to electrify NC transportation
Date: Saturday, December 09, 2017 9:35:42 AM

CAUTION: External email. Do not click links or open attachments unless verified. Send all suspicious email as an attachment to report.spam@nc.gov.

Dear Division of Air Quality,

I am writing to urge DEQ to wisely invest the \$92 million in Volkswagen settlement funds in electric vehicles and infrastructure. Taking advantage of these funds to jumpstart the electrification of North Carolina's transportation sector will mean less money sent out of state for petroleum, more in-state jobs, and cleaner air.

Specifically, I recommend that DEQ allocate the maximum allowable amount (15%) of the funds for electric vehicle charging infrastructure and installations. And I encourage DEQ to prioritize electric vehicles and buses for replacement whenever possible with the other 85% of the settlement funds. Doing so will maximize the local economic impact and the reduction of air pollution.

I encourage you to not use the funding for natural gas, propane or diesel vehicles. Further dependence on fossil fuels means more pollution. Only a transition to electric vehicles and investment in EV infrastructure will put us on the road to a 100% clean transportation sector in North Carolina.

Sincerely,

Holly Adkisson
1511-A Lansdale Drive
Charlotte, NC 28205
hhadkisson@gmail.com
(704) 532-0108

This message was sent by KnowWho, as a service provider only, on behalf of the individual noted in the sender information.

From: Peggy Sholar (pysholar@gmail.com) Sent You a Personal Message
To: [daq.NC_VWGrants](#)
Subject: [External] Use Volkswagen funds to electrify NC transportation
Date: Saturday, December 09, 2017 5:16:28 AM

CAUTION: External email. Do not click links or open attachments unless verified. Send all suspicious email as an attachment to report.spam@nc.gov.

Dear Division of Air Quality,

I am writing to urge DEQ to wisely invest the \$92 million in Volkswagen settlement funds in electric vehicles and infrastructure. Taking advantage of these funds to jumpstart the electrification of North Carolina's transportation sector will mean less money sent out of state for petroleum, more in-state jobs, and cleaner air.

Specifically, I recommend that DEQ allocate the maximum allowable amount (15%) of the funds for electric vehicle charging infrastructure and installations. And I encourage DEQ to prioritize electric vehicles and buses for replacement whenever possible with the other 85% of the settlement funds. Doing so will maximize the local economic impact and the reduction of air pollution.

I encourage you to not use the funding for natural gas, propane or diesel vehicles. Further dependence on fossil fuels means more pollution. Only a transition to electric vehicles and investment in EV infrastructure will put us on the road to a 100% clean transportation sector in North Carolina.

Sincerely,

Peggy Sholar
505 S. Cox Street
Asheboro, NC 27203
pysholar@gmail.com
(336) 625-3884

This message was sent by KnowWho, as a service provider only, on behalf of the individual noted in the sender information.

From: Joan Parks (hmrefuge@gmail.com) Sent You a Personal Message
To: [daq.NC_VWGrants](#)
Subject: [External] Use Volkswagen funds to electrify NC transportation
Date: Saturday, December 09, 2017 1:50:25 AM

CAUTION: External email. Do not click links or open attachments unless verified. Send all suspicious email as an attachment to report.spam@nc.gov.

Dear Division of Air Quality,

I am writing to urge DEQ to wisely invest the \$92 million in Volkswagen settlement funds in electric vehicles and infrastructure. Taking advantage of these funds to jumpstart the electrification of North Carolina's transportation sector will mean less money sent out of state for petroleum, more in-state jobs, and cleaner air.

Specifically, I recommend that DEQ allocate the maximum allowable amount (15%) of the funds for electric vehicle charging infrastructure and installations. And I encourage DEQ to prioritize electric vehicles and buses for replacement whenever possible with the other 85% of the settlement funds. Doing so will maximize the local economic impact and the reduction of air pollution.

I encourage you to not use the funding for natural gas, propane or diesel vehicles. Further dependence on fossil fuels means more pollution. Only a transition to electric vehicles and investment in EV infrastructure will put us on the road to a 100% clean transportation sector in North Carolina.

Sincerely,

Joan Parks
1102 Rockdale Rd
Joan, NC 28789
hmrefuge@gmail.com
(828) 586-1078

This message was sent by KnowWho, as a service provider only, on behalf of the individual noted in the sender information.

From: Ronald Clayton (se-larvae@hotmail.com) Sent You a Personal Message
To: [daq.NC_VWGrants](#)
Subject: [External] Use Volkswagen funds to electrify NC transportation
Date: Friday, December 08, 2017 10:37:41 PM

CAUTION: External email. Do not click links or open attachments unless verified. Send all suspicious email as an attachment to report.spam@nc.gov.

Dear Division of Air Quality,

I am writing to urge DEQ to wisely invest the \$92 million in Volkswagen settlement funds in electric vehicles and infrastructure. Taking advantage of these funds to jumpstart the electrification of North Carolina's transportation sector will mean less money sent out of state for petroleum, more in-state jobs, and cleaner air.

Specifically, I recommend that DEQ allocate the maximum allowable amount (15%) of the funds for electric vehicle charging infrastructure and installations. And I encourage DEQ to prioritize electric vehicles and buses for replacement whenever possible with the other 85% of the settlement funds. Doing so will maximize the local economic impact and the reduction of air pollution.

I encourage you to not use the funding for natural gas, propane or diesel vehicles. Further dependence on fossil fuels means more pollution. Only a transition to electric vehicles and investment in EV infrastructure will put us on the road to a 100% clean transportation sector in North Carolina.

Sincerely,

Ronald Clayton
10860 OLD US HIGHWAY 70
COVE CITY, NC 28523
se-larvae@hotmail.com
(336) 460-0019

This message was sent by KnowWho, as a service provider only, on behalf of the individual noted in the sender information.

From: McKenzie Bazen (mhbazen@icloud.com) Sent You a Personal Message
To: [daq.NC_VWGrants](#)
Subject: [External] Use Volkswagen funds to electrify NC transportation
Date: Friday, December 08, 2017 9:45:34 PM

CAUTION: External email. Do not click links or open attachments unless verified. Send all suspicious email as an attachment to report.spam@nc.gov.

Dear Division of Air Quality,

I am writing to urge DEQ to wisely invest the \$92 million in Volkswagen settlement funds in electric vehicles and infrastructure. Taking advantage of these funds to jumpstart the electrification of North Carolina's transportation sector will mean less money sent out of state for petroleum, more in-state jobs, and cleaner air.

Specifically, I recommend that DEQ allocate the maximum allowable amount (15%) of the funds for electric vehicle charging infrastructure and installations. And I encourage DEQ to prioritize electric vehicles and buses for replacement whenever possible with the other 85% of the settlement funds. Doing so will maximize the local economic impact and the reduction of air pollution.

I encourage you to not use the funding for natural gas, propane or diesel vehicles. Further dependence on fossil fuels means more pollution. Only a transition to electric vehicles and investment in EV infrastructure will put us on the road to a 100% clean transportation sector in North Carolina.

Sincerely,

McKenzie Bazen
120 langtree village dr
Mooresville, NC 28117
mhbazen@icloud.com
(704) 608-7404

This message was sent by KnowWho, as a service provider only, on behalf of the individual noted in the sender information.

From: Isabel McLain (isabelanne1021@gmail.com) Sent You a Personal Message
To: [daq.NC_VWGrants](#)
Subject: [External] Use Volkswagen funds to electrify NC transportation
Date: Friday, December 08, 2017 9:13:24 PM

CAUTION: External email. Do not click links or open attachments unless verified. Send all suspicious email as an attachment to report.spam@nc.gov.

Dear Division of Air Quality,

I am writing to urge DEQ to wisely invest the \$92 million in Volkswagen settlement funds in electric vehicles and infrastructure. Taking advantage of these funds to jumpstart the electrification of North Carolina's transportation sector will mean less money sent out of state for petroleum, more in-state jobs, and cleaner air.

Specifically, I recommend that DEQ allocate the maximum allowable amount (15%) of the funds for electric vehicle charging infrastructure and installations. And I encourage DEQ to prioritize electric vehicles and buses for replacement whenever possible with the other 85% of the settlement funds. Doing so will maximize the local economic impact and the reduction of air pollution.

I encourage you to not use the funding for natural gas, propane or diesel vehicles. Further dependence on fossil fuels means more pollution. Only a transition to electric vehicles and investment in EV infrastructure will put us on the road to a 100% clean transportation sector in North Carolina.

Sincerely,

Isabel McLain
5234 Lancelot Drive
Charlotte, NC 28270
isabelanne1021@gmail.com
(859) 699-6929

This message was sent by KnowWho, as a service provider only, on behalf of the individual noted in the sender information.

From: Ro Snowden (bo_snowden@yahoo.com) Sent You a Personal Message
To: [daq.NC_VWGrants](#)
Subject: [External] Use Volkswagen funds to electrify NC transportation
Date: Friday, December 08, 2017 7:42:01 PM

CAUTION: External email. Do not click links or open attachments unless verified. Send all suspicious email as an attachment to report.spam@nc.gov.

Dear Division of Air Quality,

I am writing to urge DEQ to wisely invest the \$92 million in Volkswagen settlement funds in electric vehicles and infrastructure. Taking advantage of these funds to jumpstart the electrification of North Carolina's transportation sector will mean less money sent out of state for petroleum, more in-state jobs, and cleaner air.

Specifically, I recommend that DEQ allocate the maximum allowable amount (15%) of the funds for electric vehicle charging infrastructure and installations. And I encourage DEQ to prioritize electric vehicles and buses for replacement whenever possible with the other 85% of the settlement funds. Doing so will maximize the local economic impact and the reduction of air pollution.

I encourage you to not use the funding for natural gas, propane or diesel vehicles. Further dependence on fossil fuels means more pollution. Only a transition to electric vehicles and investment in EV infrastructure will put us on the road to a 100% clean transportation sector in North Carolina.

Sincerely,

Ro Snowden
610 Castle Street, Apartment 202
Wilmington, NC 28401
bo_snowden@yahoo.com
(541) 285-8768

This message was sent by KnowWho, as a service provider only, on behalf of the individual noted in the sender information.

From: R. Schultz (ruthmschultz@aol.com) Sent You a Personal Message
To: [daq.NC_VWGrants](#)
Subject: [External] Use Volkswagen funds to electrify NC transportation
Date: Friday, December 08, 2017 7:40:22 PM

CAUTION: External email. Do not click links or open attachments unless verified. Send all suspicious email as an attachment to report.spam@nc.gov.

Dear Division of Air Quality,

I am writing to urge DEQ to wisely invest the \$92 million in Volkswagen settlement funds in electric vehicles and infrastructure. Taking advantage of these funds to jumpstart the electrification of North Carolina's transportation sector will mean less money sent out of state for petroleum, more in-state jobs, and cleaner air.

Specifically, I recommend that DEQ allocate the maximum allowable amount (15%) of the funds for electric vehicle charging infrastructure and installations. And I encourage DEQ to prioritize electric vehicles and buses for replacement whenever possible with the other 85% of the settlement funds. Doing so will maximize the local economic impact and the reduction of air pollution.

I encourage you to not use the funding for natural gas, propane or diesel vehicles. Further dependence on fossil fuels means more pollution. Only a transition to electric vehicles and investment in EV infrastructure will put us on the road to a 100% clean transportation sector in North Carolina.

Sincerely,

R. Schultz
427 Locust Dr.
Maggie Valley, NC 28751
ruthmschultz@aol.com
(828) 926-1533

This message was sent by KnowWho, as a service provider only, on behalf of the individual noted in the sender information.

From: Andrea Snyder (asnyder_hky@yahoo.com) Sent You a Personal Message
To: [daq.NC_VWGrants](#)
Subject: [External] Use Volkswagen funds to electrify NC transportation
Date: Friday, December 08, 2017 7:10:57 PM

CAUTION: External email. Do not click links or open attachments unless verified. Send all suspicious email as an attachment to report.spam@nc.gov.

Dear Division of Air Quality,

I am writing to urge DEQ to wisely invest the \$92 million in Volkswagen settlement funds in electric vehicles and infrastructure. Taking advantage of these funds to jumpstart the electrification of North Carolina's transportation sector will mean less money sent out of state for petroleum, more in-state jobs, and cleaner air.

Specifically, I recommend that DEQ allocate the maximum allowable amount (15%) of the funds for electric vehicle charging infrastructure and installations. And I encourage DEQ to prioritize electric vehicles and buses for replacement whenever possible with the other 85% of the settlement funds. Doing so will maximize the local economic impact and the reduction of air pollution.

I encourage you to not use the funding for natural gas, propane or diesel vehicles. Further dependence on fossil fuels means more pollution. Only a transition to electric vehicles and investment in EV infrastructure will put us on the road to a 100% clean transportation sector in North Carolina.

Sincerely,

Andrea Snyder
228F 14th Ave SE
Hickory, NC 28602
asnyder_hky@yahoo.com
(828) 328-4745

This message was sent by KnowWho, as a service provider only, on behalf of the individual noted in the sender information.

From: William Mullins (cinema3334@yahoo.com) Sent You a Personal Message
To: [daq.NC_VWGrants](#)
Subject: [External] Use Volkswagen funds to electrify NC transportation
Date: Friday, December 08, 2017 3:45:47 PM

CAUTION: External email. Do not click links or open attachments unless verified. Send all suspicious email as an attachment to report.spam@nc.gov.

Dear Division of Air Quality,

I am writing to urge DEQ to wisely invest the \$92 million in Volkswagen settlement funds in electric vehicles and infrastructure. Taking advantage of these funds to jumpstart the electrification of North Carolina's transportation sector will mean less money sent out of state for petroleum, more in-state jobs, and cleaner air.

Specifically, I recommend that DEQ allocate the maximum allowable amount (15%) of the funds for electric vehicle charging infrastructure and installations. And I encourage DEQ to prioritize electric vehicles and buses for replacement whenever possible with the other 85% of the settlement funds. Doing so will maximize the local economic impact and the reduction of air pollution.

I encourage you to not use the funding for natural gas, propane or diesel vehicles. Further dependence on fossil fuels means more pollution. Only a transition to electric vehicles and investment in EV infrastructure will put us on the road to a 100% clean transportation sector in North Carolina.

Sincerely,

William Mullins
305 Hedingham Lane
Wilmington, NC 28412
cinema3334@yahoo.com
(910) 386-1996

This message was sent by KnowWho, as a service provider only, on behalf of the individual noted in the sender information.

From: Adrian Smith (adsmith57@charter.net) Sent You a Personal Message
To: [daq.NC_VWGrants](#)
Subject: [External] Use Volkswagen funds to electrify NC transportation
Date: Friday, December 08, 2017 3:39:46 PM

CAUTION: External email. Do not click links or open attachments unless verified. Send all suspicious email as an attachment to report.spam@nc.gov.

Dear Division of Air Quality,

I am writing to urge DEQ to wisely invest the \$92 million in Volkswagen settlement funds in electric vehicles and infrastructure. Taking advantage of these funds to jumpstart the electrification of North Carolina's transportation sector will mean less money sent out of state for petroleum, more in-state jobs, and cleaner air.

Specifically, I recommend that DEQ allocate the maximum allowable amount (15%) of the funds for electric vehicle charging infrastructure and installations. And I encourage DEQ to prioritize electric vehicles and buses for replacement whenever possible with the other 85% of the settlement funds. Doing so will maximize the local economic impact and the reduction of air pollution.

I encourage you to not use the funding for natural gas, propane or diesel vehicles. Further dependence on fossil fuels means more pollution. Only a transition to electric vehicles and investment in EV infrastructure will put us on the road to a 100% clean transportation sector in North Carolina.

Sincerely,

Adrian Smith
PO Box 265 (110 Jones St)
Moncure, NC 27559
adsmith57@charter.net
(919) 542-3807

This message was sent by KnowWho, as a service provider only, on behalf of the individual noted in the sender information.

From: Ryan Draper (raptorred01@yahoo.com) Sent You a Personal Message
To: [daq.NC_VWGrants](#)
Subject: [External] Use Volkswagen funds to electrify NC transportation
Date: Friday, December 08, 2017 3:20:51 PM

CAUTION: External email. Do not click links or open attachments unless verified. Send all suspicious email as an attachment to report.spam@nc.gov.

Dear Division of Air Quality,

I am writing to urge DEQ to wisely invest the \$92 million in Volkswagen settlement funds in electric vehicles and infrastructure. Taking advantage of these funds to jumpstart the electrification of North Carolina's transportation sector will mean less money sent out of state for petroleum, more in-state jobs, and cleaner air.

Specifically, I recommend that DEQ allocate the maximum allowable amount (15%) of the funds for electric vehicle charging infrastructure and installations. And I encourage DEQ to prioritize electric vehicles and buses for replacement whenever possible with the other 85% of the settlement funds. Doing so will maximize the local economic impact and the reduction of air pollution.

I encourage you to not use the funding for natural gas, propane or diesel vehicles. Further dependence on fossil fuels means more pollution. Only a transition to electric vehicles and investment in EV infrastructure will put us on the road to a 100% clean transportation sector in North Carolina.

Sincerely,

Ryan Draper
101 Foxridge Road
Ryan, NC 27514
raptorred01@yahoo.com
(919) 968-0690

This message was sent by KnowWho, as a service provider only, on behalf of the individual noted in the sender information.

From: Sierra Midgette (sierramidgette@gmail.com) Sent You a Personal Message
To: [daq.NC_VWGrants](#)
Subject: [External] Use Volkswagen funds to electrify NC transportation
Date: Friday, December 08, 2017 3:19:09 PM

CAUTION: External email. Do not click links or open attachments unless verified. Send all suspicious email as an attachment to report.spam@nc.gov.

Dear Division of Air Quality,

I am writing to urge DEQ to wisely invest the \$92 million in Volkswagen settlement funds in electric vehicles and infrastructure. Taking advantage of these funds to jumpstart the electrification of North Carolina's transportation sector will mean less money sent out of state for petroleum, more in-state jobs, and cleaner air.

Specifically, I recommend that DEQ allocate the maximum allowable amount (15%) of the funds for electric vehicle charging infrastructure and installations. And I encourage DEQ to prioritize electric vehicles and buses for replacement whenever possible with the other 85% of the settlement funds. Doing so will maximize the local economic impact and the reduction of air pollution.

I encourage you to not use the funding for natural gas, propane or diesel vehicles. Further dependence on fossil fuels means more pollution. Only a transition to electric vehicles and investment in EV infrastructure will put us on the road to a 100% clean transportation sector in North Carolina.

Sincerely,

Sierra Midgette
27 Barbican Way
Manteo, NC 27954
sierramidgette@gmail.com
(252) 581-6033

This message was sent by KnowWho, as a service provider only, on behalf of the individual noted in the sender information.

From: Lucy Tyndall (beaverfalls1@yahoo.com) Sent You a Personal Message
To: [daq.NC_VWGrants](#)
Subject: [External] Use Volkswagen funds to electrify NC transportation
Date: Friday, December 08, 2017 3:00:17 PM

CAUTION: External email. Do not click links or open attachments unless verified. Send all suspicious email as an attachment to report.spam@nc.gov.

Dear Division of Air Quality,

I am writing to urge DEQ to wisely invest the \$92 million in Volkswagen settlement funds in electric vehicles and infrastructure. Taking advantage of these funds to jumpstart the electrification of North Carolina's transportation sector will mean less money sent out of state for petroleum, more in-state jobs, and cleaner air.

Specifically, I recommend that DEQ allocate the maximum allowable amount (15%) of the funds for electric vehicle charging infrastructure and installations. And I encourage DEQ to prioritize electric vehicles and buses for replacement whenever possible with the other 85% of the settlement funds. Doing so will maximize the local economic impact and the reduction of air pollution.

I encourage you to not use the funding for natural gas, propane or diesel vehicles. Further dependence on fossil fuels means more pollution. Only a transition to electric vehicles and investment in EV infrastructure will put us on the road to a 100% clean transportation sector in North Carolina.

Sincerely,

Lucy Tyndall
3977 Flannery Lane
High Point, NC 27265
beaverfalls1@yahoo.com
(336) 454-4809

This message was sent by KnowWho, as a service provider only, on behalf of the individual noted in the sender information.

From: Michelle Bentley (michelleleegrant@msn.com) Sent You a Personal Message
To: [daq.NC_VWGrants](#)
Subject: [External] Use Volkswagen funds to electrify NC transportation
Date: Friday, December 08, 2017 1:49:25 PM

CAUTION: External email. Do not click links or open attachments unless verified. Send all suspicious email as an attachment to report.spam@nc.gov.

Dear Division of Air Quality,

I am writing to urge DEQ to wisely invest the \$92 million in Volkswagen settlement funds in electric vehicles and infrastructure. Taking advantage of these funds to jumpstart the electrification of North Carolina's transportation sector will mean less money sent out of state for petroleum, more in-state jobs, and cleaner air.

Specifically, I recommend that DEQ allocate the maximum allowable amount (15%) of the funds for electric vehicle charging infrastructure and installations. And I encourage DEQ to prioritize electric vehicles and buses for replacement whenever possible with the other 85% of the settlement funds. Doing so will maximize the local economic impact and the reduction of air pollution.

I encourage you to not use the funding for natural gas, propane or diesel vehicles. Further dependence on fossil fuels means more pollution. Only a transition to electric vehicles and investment in EV infrastructure will put us on the road to a 100% clean transportation sector in North Carolina.

Sincerely,

Michelle Bentley
Pob 1861
Bryson city, NC 28713
michelleleegrant@msn.com
(828) 236-2627

This message was sent by KnowWho, as a service provider only, on behalf of the individual noted in the sender information.

From: William S.T. Holcomb (doslobos@charter.net) Sent You a Personal Message
To: [daq.NC_VWGrants](#)
Subject: [External] Use Volkswagen funds to electrify NC transportation
Date: Friday, December 08, 2017 12:25:51 PM

CAUTION: External email. Do not click links or open attachments unless verified. Send all suspicious email as an attachment to report.spam@nc.gov.

Dear Division of Air Quality,

I am writing to urge DEQ to wisely invest the \$92 million in Volkswagen settlement funds in electric vehicles and infrastructure. Taking advantage of these funds to jumpstart the electrification of North Carolina's transportation sector will mean less money sent out of state for petroleum, more in-state jobs, and cleaner air.

Specifically, I recommend that DEQ allocate the maximum allowable amount (15%) of the funds for electric vehicle charging infrastructure and installations. And I encourage DEQ to prioritize electric vehicles and buses for replacement whenever possible with the other 85% of the settlement funds. Doing so will maximize the local economic impact and the reduction of air pollution.

I encourage you to not use the funding for natural gas, propane or diesel vehicles. Further dependence on fossil fuels means more pollution. Only a transition to electric vehicles and investment in EV infrastructure will put us on the road to a 100% clean transportation sector in North Carolina.

Sincerely,

William S.T. Holcomb
190 hawks haunt lane
tryon, NC 28782
doslobos@charter.net
(612) 871-9569

This message was sent by KnowWho, as a service provider only, on behalf of the individual noted in the sender information.

From: Mary Lou Buck (maryloubuc@aol.com) Sent You a Personal Message
To: [daq.NC_VWGrants](#)
Subject: [External] Use Volkswagen funds to electrify NC transportation
Date: Friday, December 08, 2017 10:30:39 AM

CAUTION: External email. Do not click links or open attachments unless verified. Send all suspicious email as an attachment to report.spam@nc.gov.

Dear Division of Air Quality,

I am writing to urge DEQ to wisely invest the \$92 million in Volkswagen settlement funds in electric vehicles and infrastructure. Taking advantage of these funds to jumpstart the electrification of North Carolina's transportation sector will mean less money sent out of state for petroleum, more in-state jobs, and cleaner air.

Specifically, I recommend that DEQ allocate the maximum allowable amount (15%) of the funds for electric vehicle charging infrastructure and installations. And I encourage DEQ to prioritize electric vehicles and buses for replacement whenever possible with the other 85% of the settlement funds. Doing so will maximize the local economic impact and the reduction of air pollution.

I encourage you to not use the funding for natural gas, propane or diesel vehicles. Further dependence on fossil fuels means more pollution. Only a transition to electric vehicles and investment in EV infrastructure will put us on the road to a 100% clean transportation sector in North Carolina.

Sincerely,

Mary Lou Buck
3406 Mar Vista Circle
Charlotte, NC 28209
maryloubuc@aol.com
(704) 525-2293

This message was sent by KnowWho, as a service provider only, on behalf of the individual noted in the sender information.

From: Thomas Cann (tcann@triad.rr.com) Sent You a Personal Message
To: [daq.NC_VWGrants](#)
Subject: [External] Use Volkswagen funds to electrify NC transportation
Date: Friday, December 08, 2017 10:18:59 AM

CAUTION: External email. Do not click links or open attachments unless verified. Send all suspicious email as an attachment to report.spam@nc.gov.

Dear Division of Air Quality,

I am writing to urge DEQ to wisely invest the \$92 million in Volkswagen settlement funds in electric vehicles and infrastructure. Taking advantage of these funds to jumpstart the electrification of North Carolina's transportation sector will mean less money sent out of state for petroleum, more in-state jobs, and cleaner air.

Specifically, I recommend that DEQ allocate the maximum allowable amount (15%) of the funds for electric vehicle charging infrastructure and installations. And I encourage DEQ to prioritize electric vehicles and buses for replacement whenever possible with the other 85% of the settlement funds. Doing so will maximize the local economic impact and the reduction of air pollution.

I encourage you to not use the funding for natural gas, propane or diesel vehicles. Further dependence on fossil fuels means more pollution. Only a transition to electric vehicles and investment in EV infrastructure will put us on the road to a 100% clean transportation sector in North Carolina.

Sincerely,

Thomas Cann
3605 Dewsbury Road
Winston Salem, NC 27104
tcann@triad.rr.com
(336) 760-2721

This message was sent by KnowWho, as a service provider only, on behalf of the individual noted in the sender information.

From: Caroline Ervin (ervincaroline0@gmail.com) Sent You a Personal Message
To: [daq.NC_VWGrants](#)
Subject: [External] Use Volkswagen funds to electrify NC transportation
Date: Friday, December 08, 2017 10:05:15 AM

CAUTION: External email. Do not click links or open attachments unless verified. Send all suspicious email as an attachment to report.spam@nc.gov.

Dear Division of Air Quality,

I am writing to urge DEQ to wisely invest the \$92 million in Volkswagen settlement funds in electric vehicles and infrastructure. Taking advantage of these funds to jumpstart the electrification of North Carolina's transportation sector will mean less money sent out of state for petroleum, more in-state jobs, and cleaner air.

Specifically, I recommend that DEQ allocate the maximum allowable amount (15%) of the funds for electric vehicle charging infrastructure and installations. And I encourage DEQ to prioritize electric vehicles and buses for replacement whenever possible with the other 85% of the settlement funds. Doing so will maximize the local economic impact and the reduction of air pollution.

I encourage you to not use the funding for natural gas, propane or diesel vehicles. Further dependence on fossil fuels means more pollution. Only a transition to electric vehicles and investment in EV infrastructure will put us on the road to a 100% clean transportation sector in North Carolina.

Sincerely,

Caroline Ervin
515 Lenoir Street
Morganton, NC 28655
ervincaroline0@gmail.com
(828) 448-5387

This message was sent by KnowWho, as a service provider only, on behalf of the individual noted in the sender information.

From: Beth Brown (beth_borchelt@hotmail.com) Sent You a Personal Message
To: [daq.NC_VWGrants](#)
Subject: [External] Use Volkswagen funds to electrify NC transportation
Date: Friday, December 08, 2017 9:03:54 AM

CAUTION: External email. Do not click links or open attachments unless verified. Send all suspicious email as an attachment to report.spam@nc.gov.

Dear Division of Air Quality,

I am writing to urge DEQ to wisely invest the \$92 million in Volkswagen settlement funds in electric vehicles and infrastructure. Taking advantage of these funds to jumpstart the electrification of North Carolina's transportation sector will mean less money sent out of state for petroleum, more in-state jobs, and cleaner air.

Specifically, I recommend that DEQ allocate the maximum allowable amount (15%) of the funds for electric vehicle charging infrastructure and installations. And I encourage DEQ to prioritize electric vehicles and buses for replacement whenever possible with the other 85% of the settlement funds. Doing so will maximize the local economic impact and the reduction of air pollution.

I encourage you to not use the funding for natural gas, propane or diesel vehicles. Further dependence on fossil fuels means more pollution. Only a transition to electric vehicles and investment in EV infrastructure will put us on the road to a 100% clean transportation sector in North Carolina.

Sincerely,

Beth Brown
1812 Thomas Ave
Charlotte, NC 28205
beth_borchelt@hotmail.com
(704) 909-6216

This message was sent by KnowWho, as a service provider only, on behalf of the individual noted in the sender information.

From: B Pfaff (bpfaff@ymail.com) Sent You a Personal Message
To: [daq.NC_VWGrants](#)
Subject: [External] Use Volkswagen funds to electrify NC transportation
Date: Friday, December 08, 2017 8:23:49 AM

CAUTION: External email. Do not click links or open attachments unless verified. Send all suspicious email as an attachment to report.spam@nc.gov.

Dear Division of Air Quality,

I am writing to urge DEQ to wisely invest the \$92 million in Volkswagen settlement funds in electric vehicles and infrastructure. Taking advantage of these funds to jumpstart the electrification of North Carolina's transportation sector will mean less money sent out of state for petroleum, more in-state jobs, and cleaner air.

Specifically, I recommend that DEQ allocate the maximum allowable amount (15%) of the funds for electric vehicle charging infrastructure and installations. And I encourage DEQ to prioritize electric vehicles and buses for replacement whenever possible with the other 85% of the settlement funds. Doing so will maximize the local economic impact and the reduction of air pollution.

I encourage you to not use the funding for natural gas, propane or diesel vehicles. Further dependence on fossil fuels means more pollution. Only a transition to electric vehicles and investment in EV infrastructure will put us on the road to a 100% clean transportation sector in North Carolina.

Sincerely,

B Pfaff
226 w henderson st
Salisbury, NC 28144
bpfaff@ymail.com
(704) 763-6207

This message was sent by KnowWho, as a service provider only, on behalf of the individual noted in the sender information.

From: Acee Lindem (acee@lindem.com) Sent You a Personal Message
To: [daq.NC_VWGrants](#)
Subject: [External] Use Volkswagen funds to electrify NC transportation
Date: Friday, December 08, 2017 7:22:27 AM

CAUTION: External email. Do not click links or open attachments unless verified. Send all suspicious email as an attachment to report.spam@nc.gov.

Dear Division of Air Quality,

I am writing to urge DEQ to wisely invest the \$92 million in Volkswagen settlement funds in electric vehicles and infrastructure. Taking advantage of these funds to jumpstart the electrification of North Carolina's transportation sector will mean less money sent out of state for petroleum, more in-state jobs, and cleaner air.

Specifically, I recommend that DEQ allocate the maximum allowable amount (15%) of the funds for electric vehicle charging infrastructure and installations. And I encourage DEQ to prioritize electric vehicles and buses for replacement whenever possible with the other 85% of the settlement funds. Doing so will maximize the local economic impact and the reduction of air pollution.

I encourage you to not use the funding for natural gas, propane or diesel vehicles. Further dependence on fossil fuels means more pollution. Only a transition to electric vehicles and investment in EV infrastructure will put us on the road to a 100% clean transportation sector in North Carolina.

Sincerely,

Acee Lindem
301 Midenhall Way
Cary, NC 27513
acee@lindem.com
(919) 387-6971

This message was sent by KnowWho, as a service provider only, on behalf of the individual noted in the sender information.

From: Felicia Katsilis (eveyhammond@tutanota.com) Sent You a Personal Message
To: [daq.NC_VWGrants](#)
Subject: [External] Use Volkswagen funds to electrify NC transportation
Date: Friday, December 08, 2017 6:20:15 AM

CAUTION: External email. Do not click links or open attachments unless verified. Send all suspicious email as an attachment to report.spam@nc.gov.

Dear Division of Air Quality,

I am writing to urge DEQ to wisely invest the \$92 million in Volkswagen settlement funds in electric vehicles and infrastructure. Taking advantage of these funds to jumpstart the electrification of North Carolina's transportation sector will mean less money sent out of state for petroleum, more in-state jobs, and cleaner air.

Specifically, I recommend that DEQ allocate the maximum allowable amount (15%) of the funds for electric vehicle charging infrastructure and installations. And I encourage DEQ to prioritize electric vehicles and buses for replacement whenever possible with the other 85% of the settlement funds. Doing so will maximize the local economic impact and the reduction of air pollution.

I encourage you to not use the funding for natural gas, propane or diesel vehicles. Further dependence on fossil fuels means more pollution. Only a transition to electric vehicles and investment in EV infrastructure will put us on the road to a 100% clean transportation sector in North Carolina.

Sincerely,

Felicia Katsilis
7944 Vance Rd
Kernersville, NC 27284
eveyhammond@tutanota.com
(336) 904-9494

This message was sent by KnowWho, as a service provider only, on behalf of the individual noted in the sender information.

From: Robert Foy (rtfoy708@gmail.com) Sent You a Personal Message
To: daq.NC_VWGrants
Subject: [External] Use Volkswagen funds to electrify NC transportation
Date: Friday, December 08, 2017 5:02:32 AM

CAUTION: External email. Do not click links or open attachments unless verified. Send all suspicious email as an attachment to report.spam@nc.gov.

Dear Division of Air Quality,

I am writing to urge DEQ to wisely invest the \$92 million in Volkswagen settlement funds in electric vehicles and infrastructure. Taking advantage of these funds to jumpstart the electrification of North Carolina's transportation sector will mean less money sent out of state for petroleum, more in-state jobs, and cleaner air.

Specifically, I recommend that DEQ allocate the maximum allowable amount (15%) of the funds for electric vehicle charging infrastructure and installations. And I encourage DEQ to prioritize electric vehicles and buses for replacement whenever possible with the other 85% of the settlement funds. Doing so will maximize the local economic impact and the reduction of air pollution.

I encourage you to not use the funding for natural gas, propane or diesel vehicles. Further dependence on fossil fuels means more pollution. Only a transition to electric vehicles and investment in EV infrastructure will put us on the road to a 100% clean transportation sector in North Carolina.

Sincerely,

Robert Foy
2216 Scotts Hill Loop Road
Wilmington, NC 28411
rtfoy708@gmail.com
(910) 686-2914

This message was sent by KnowWho, as a service provider only, on behalf of the individual noted in the sender information.

From: Jason Gaylor (jasongaylor78@yahoo.com) Sent You a Personal Message
To: [daq.NC_VWGrants](#)
Subject: [External] Use Volkswagen funds to electrify NC transportation
Date: Thursday, December 07, 2017 11:49:29 PM

CAUTION: External email. Do not click links or open attachments unless verified. Send all suspicious email as an attachment to report.spam@nc.gov.

Dear Division of Air Quality,

I am writing to urge DEQ to wisely invest the \$92 million in Volkswagen settlement funds in electric vehicles and infrastructure. Taking advantage of these funds to jumpstart the electrification of North Carolina's transportation sector will mean less money sent out of state for petroleum, more in-state jobs, and cleaner air.

Specifically, I recommend that DEQ allocate the maximum allowable amount (15%) of the funds for electric vehicle charging infrastructure and installations. And I encourage DEQ to prioritize electric vehicles and buses for replacement whenever possible with the other 85% of the settlement funds. Doing so will maximize the local economic impact and the reduction of air pollution.

I encourage you to not use the funding for natural gas, propane or diesel vehicles. Further dependence on fossil fuels means more pollution. Only a transition to electric vehicles and investment in EV infrastructure will put us on the road to a 100% clean transportation sector in North Carolina.

Sincerely,

Jason Gaylor
14 Peaceful Dr
Roanoke Rapids, NC 27870
jasongaylor78@yahoo.com
(434) 577-2410

This message was sent by KnowWho, as a service provider only, on behalf of the individual noted in the sender information.

From: Melissa Bloom (missyswb@aol.com) Sent You a Personal Message
To: [daq.NC_VWGrants](#)
Subject: [External] Use Volkswagen funds to electrify NC transportation
Date: Thursday, December 07, 2017 10:28:48 PM

CAUTION: External email. Do not click links or open attachments unless verified. Send all suspicious email as an attachment to report.spam@nc.gov.

Dear Division of Air Quality,

I am writing to urge DEQ to wisely invest the \$92 million in Volkswagen settlement funds in electric vehicles and infrastructure. Taking advantage of these funds to jumpstart the electrification of North Carolina's transportation sector will mean less money sent out of state for petroleum, more in-state jobs, and cleaner air.

Specifically, I recommend that DEQ allocate the maximum allowable amount (15%) of the funds for electric vehicle charging infrastructure and installations. And I encourage DEQ to prioritize electric vehicles and buses for replacement whenever possible with the other 85% of the settlement funds. Doing so will maximize the local economic impact and the reduction of air pollution.

I encourage you to not use the funding for natural gas, propane or diesel vehicles. Further dependence on fossil fuels means more pollution. Only a transition to electric vehicles and investment in EV infrastructure will put us on the road to a 100% clean transportation sector in North Carolina.

Sincerely,

Melissa Bloom
1066 Beans Creek Rd
Bakersville, NC 28705
missyswb@aol.com
(828) 385-1657

This message was sent by KnowWho, as a service provider only, on behalf of the individual noted in the sender information.

From: Ervin Kelman (ekel0613@cs.com) Sent You a Personal Message
To: [daq.NC_VWGrants](#)
Subject: [External] Use Volkswagen funds to electrify NC transportation
Date: Thursday, December 07, 2017 9:35:16 PM

CAUTION: External email. Do not click links or open attachments unless verified. Send all suspicious email as an attachment to report.spam@nc.gov.

Dear Division of Air Quality,

I am writing to urge DEQ to wisely invest the \$92 million in Volkswagen settlement funds in electric vehicles and infrastructure. Taking advantage of these funds to jumpstart the electrification of North Carolina's transportation sector will mean less money sent out of state for petroleum, more in-state jobs, and cleaner air.

Specifically, I recommend that DEQ allocate the maximum allowable amount (15%) of the funds for electric vehicle charging infrastructure and installations. And I encourage DEQ to prioritize electric vehicles and buses for replacement whenever possible with the other 85% of the settlement funds. Doing so will maximize the local economic impact and the reduction of air pollution.

I encourage you to not use the funding for natural gas, propane or diesel vehicles. Further dependence on fossil fuels means more pollution. Only a transition to electric vehicles and investment in EV infrastructure will put us on the road to a 100% clean transportation sector in North Carolina.

Sincerely,

Ervin Kelman
7300 Haw Ridge Rd.
Summerfield, NC 27358
ekel0613@cs.com
(336) 643-6962

This message was sent by KnowWho, as a service provider only, on behalf of the individual noted in the sender information.

From: Renee Reese (reneereese0@gmail.com) Sent You a Personal Message
To: [daq.NC_VWGrants](#)
Subject: [External] Use Volkswagen funds to electrify NC transportation
Date: Thursday, December 07, 2017 9:04:52 PM

CAUTION: External email. Do not click links or open attachments unless verified. Send all suspicious email as an attachment to report.spam@nc.gov.

Dear Division of Air Quality,

I am writing to urge DEQ to wisely invest the \$92 million in Volkswagen settlement funds in electric vehicles and infrastructure. Taking advantage of these funds to jumpstart the electrification of North Carolina's transportation sector will mean less money sent out of state for petroleum, more in-state jobs, and cleaner air.

Specifically, I recommend that DEQ allocate the maximum allowable amount (15%) of the funds for electric vehicle charging infrastructure and installations. And I encourage DEQ to prioritize electric vehicles and buses for replacement whenever possible with the other 85% of the settlement funds. Doing so will maximize the local economic impact and the reduction of air pollution.

I encourage you to not use the funding for natural gas, propane or diesel vehicles. Further dependence on fossil fuels means more pollution. Only a transition to electric vehicles and investment in EV infrastructure will put us on the road to a 100% clean transportation sector in North Carolina.

Sincerely,

Renee Reese
306 Wendover Heights Circle
Charlotte, NC 28211
reneereese0@gmail.com
(704) 763-1751

This message was sent by KnowWho, as a service provider only, on behalf of the individual noted in the sender information.

From: Stephen Knowlton (stephendknowltonmd@gmail.com) Sent You a Personal Message
To: [daq.NC_VWGrants](#)
Subject: [External] Use Volkswagen funds to electrify NC transportation
Date: Thursday, December 07, 2017 8:18:53 PM

CAUTION: External email. Do not click links or open attachments unless verified. Send all suspicious email as an attachment to report.spam@nc.gov.

Dear Division of Air Quality,

I am writing to urge DEQ to wisely invest the \$92 million in Volkswagen settlement funds in electric vehicles and infrastructure. Taking advantage of these funds to jumpstart the electrification of North Carolina's transportation sector will mean less money sent out of state for petroleum, more in-state jobs, and cleaner air.

Specifically, I recommend that DEQ allocate the maximum allowable amount (15%) of the funds for electric vehicle charging infrastructure and installations. And I encourage DEQ to prioritize electric vehicles and buses for replacement whenever possible with the other 85% of the settlement funds. Doing so will maximize the local economic impact and the reduction of air pollution.

I encourage you to not use the funding for natural gas, propane or diesel vehicles. Further dependence on fossil fuels means more pollution. Only a transition to electric vehicles and investment in EV infrastructure will put us on the road to a 100% clean transportation sector in North Carolina.

Sincerely,

Stephen Knowlton
1045 Flat Rock Road
Reidsville, NC 27320
stephendknowltonmd@gmail.com
(336) 349-7114

This message was sent by KnowWho, as a service provider only, on behalf of the individual noted in the sender information.

From: Virginia Duquet (virginia_duquet@charter.net) Sent You a Personal Message
To: [daq.NC_VWGrants](#)
Subject: [External] Use Volkswagen funds to electrify NC transportation
Date: Thursday, December 07, 2017 6:35:04 PM

CAUTION: External email. Do not click links or open attachments unless verified. Send all suspicious email as an attachment to report.spam@nc.gov.

Dear Division of Air Quality,

I am writing to urge DEQ to wisely invest the \$92 million in Volkswagen settlement funds in electric vehicles and infrastructure. Taking advantage of these funds to jumpstart the electrification of North Carolina's transportation sector will mean less money sent out of state for petroleum, more in-state jobs, and cleaner air.

Specifically, I recommend that DEQ allocate the maximum allowable amount (15%) of the funds for electric vehicle charging infrastructure and installations. And I encourage DEQ to prioritize electric vehicles and buses for replacement whenever possible with the other 85% of the settlement funds. Doing so will maximize the local economic impact and the reduction of air pollution.

I encourage you to not use the funding for natural gas, propane or diesel vehicles. Further dependence on fossil fuels means more pollution. Only a transition to electric vehicles and investment in EV infrastructure will put us on the road to a 100% clean transportation sector in North Carolina.

Sincerely,

Virginia Duquet
119 Estes Court
Virginia, NC 28806
virginia_duquet@charter.net
(828) 252-2729

This message was sent by KnowWho, as a service provider only, on behalf of the individual noted in the sender information.

From: Lindsay Black (lindsaygiants@gmail.com) Sent You a Personal Message
To: [daq.NC_VWGrants](#)
Subject: [External] Use Volkswagen funds to electrify NC transportation
Date: Thursday, December 07, 2017 6:05:15 PM

CAUTION: External email. Do not click links or open attachments unless verified. Send all suspicious email as an attachment to report.spam@nc.gov.

Dear Division of Air Quality,

I am writing to urge DEQ to wisely invest the \$92 million in Volkswagen settlement funds in electric vehicles and infrastructure. Taking advantage of these funds to jumpstart the electrification of North Carolina's transportation sector will mean less money sent out of state for petroleum, more in-state jobs, and cleaner air.

Specifically, I recommend that DEQ allocate the maximum allowable amount (15%) of the funds for electric vehicle charging infrastructure and installations. And I encourage DEQ to prioritize electric vehicles and buses for replacement whenever possible with the other 85% of the settlement funds. Doing so will maximize the local economic impact and the reduction of air pollution.

I encourage you to not use the funding for natural gas, propane or diesel vehicles. Further dependence on fossil fuels means more pollution. Only a transition to electric vehicles and investment in EV infrastructure will put us on the road to a 100% clean transportation sector in North Carolina.

Sincerely,

Lindsay Black
56 Salem Ave
Asheville, NC 28804
lindsaygiants@gmail.com
(516) 815-1911

This message was sent by KnowWho, as a service provider only, on behalf of the individual noted in the sender information.

From: Beverly McIllwain (wachemom@aol.com) Sent You a Personal Message
To: [daq.NC_VWGrants](#)
Subject: [External] Use Volkswagen funds to electrify NC transportation
Date: Thursday, December 07, 2017 5:27:19 PM

CAUTION: External email. Do not click links or open attachments unless verified. Send all suspicious email as an attachment to report.spam@nc.gov.

Dear Division of Air Quality,

I am writing to urge DEQ to wisely invest the \$92 million in Volkswagen settlement funds in electric vehicles and infrastructure. Taking advantage of these funds to jumpstart the electrification of North Carolina's transportation sector will mean less money sent out of state for petroleum, more in-state jobs, and cleaner air.

Specifically, I recommend that DEQ allocate the maximum allowable amount (15%) of the funds for electric vehicle charging infrastructure and installations. And I encourage DEQ to prioritize electric vehicles and buses for replacement whenever possible with the other 85% of the settlement funds. Doing so will maximize the local economic impact and the reduction of air pollution.

I encourage you to not use the funding for natural gas, propane or diesel vehicles. Further dependence on fossil fuels means more pollution. Only a transition to electric vehicles and investment in EV infrastructure will put us on the road to a 100% clean transportation sector in North Carolina.

Sincerely,

Beverly McIllwain
5413 Breakwater Drive
Granite Falls, NC 28630
wachemom@aol.com
(828) 396-2956

This message was sent by KnowWho, as a service provider only, on behalf of the individual noted in the sender information.

From: Kari Richmond (karirichmond@charter.net) Sent You a Personal Message
To: daq.NC_VWGrants
Subject: [External] Use Volkswagen funds to electrify NC transportation
Date: Thursday, December 07, 2017 4:33:52 PM

CAUTION: External email. Do not click links or open attachments unless verified. Send all suspicious email as an attachment to report.spam@nc.gov.

Dear Division of Air Quality,

I am writing to urge DEQ to wisely invest the \$92 million in Volkswagen settlement funds in electric vehicles and infrastructure. Taking advantage of these funds to jumpstart the electrification of North Carolina's transportation sector will mean less money sent out of state for petroleum, more in-state jobs, and cleaner air.

Specifically, I recommend that DEQ allocate the maximum allowable amount (15%) of the funds for electric vehicle charging infrastructure and installations. And I encourage DEQ to prioritize electric vehicles and buses for replacement whenever possible with the other 85% of the settlement funds. Doing so will maximize the local economic impact and the reduction of air pollution.

I encourage you to not use the funding for natural gas, propane or diesel vehicles. Further dependence on fossil fuels means more pollution. Only a transition to electric vehicles and investment in EV infrastructure will put us on the road to a 100% clean transportation sector in North Carolina.

Sincerely,

Kari Richmond
11 Talmadge St
Asheville, NC 28806
karirichmond@charter.net
(828) 545-0990

This message was sent by KnowWho, as a service provider only, on behalf of the individual noted in the sender information.

From: Johnny George (txs.johnny@icloud.com) Sent You a Personal Message
To: [daq.NC_VWGrants](#)
Subject: [External] Use Volkswagen funds to electrify NC transportation
Date: Thursday, December 07, 2017 4:26:46 PM

CAUTION: External email. Do not click links or open attachments unless verified. Send all suspicious email as an attachment to report.spam@nc.gov.

Dear Division of Air Quality,

I am writing to urge DEQ to wisely invest the \$92 million in Volkswagen settlement funds in electric vehicles and infrastructure. Taking advantage of these funds to jumpstart the electrification of North Carolina's transportation sector will mean less money sent out of state for petroleum, more in-state jobs, and cleaner air.

Specifically, I recommend that DEQ allocate the maximum allowable amount (15%) of the funds for electric vehicle charging infrastructure and installations. And I encourage DEQ to prioritize electric vehicles and buses for replacement whenever possible with the other 85% of the settlement funds. Doing so will maximize the local economic impact and the reduction of air pollution.

I encourage you to not use the funding for natural gas, propane or diesel vehicles. Further dependence on fossil fuels means more pollution. Only a transition to electric vehicles and investment in EV infrastructure will put us on the road to a 100% clean transportation sector in North Carolina.

Sincerely,

Johnny George
1235 East Blvd
Charlotte, NC 28203
txs.johnny@icloud.com
(202) 524-0644

This message was sent by KnowWho, as a service provider only, on behalf of the individual noted in the sender information.

From: Debbie Kenyon (dcjkenyon@aol.com) Sent You a Personal Message
To: [daq.NC_VWGrants](#)
Subject: [External] Use Volkswagen funds to electrify NC transportation
Date: Thursday, December 07, 2017 3:13:52 PM

CAUTION: External email. Do not click links or open attachments unless verified. Send all suspicious email as an attachment to report.spam@nc.gov.

Dear Division of Air Quality,

I am writing to urge DEQ to wisely invest the \$92 million in Volkswagen settlement funds in electric vehicles and infrastructure. Taking advantage of these funds to jumpstart the electrification of North Carolina's transportation sector will mean less money sent out of state for petroleum, more in-state jobs, and cleaner air.

Specifically, I recommend that DEQ allocate the maximum allowable amount (15%) of the funds for electric vehicle charging infrastructure and installations. And I encourage DEQ to prioritize electric vehicles and buses for replacement whenever possible with the other 85% of the settlement funds. Doing so will maximize the local economic impact and the reduction of air pollution.

I encourage you to not use the funding for natural gas, propane or diesel vehicles. Further dependence on fossil fuels means more pollution. Only a transition to electric vehicles and investment in EV infrastructure will put us on the road to a 100% clean transportation sector in North Carolina.

Sincerely,

Debbie Kenyon
509 GABLEFIELD LN
APEX, NC 27502
dcjkenyon@aol.com
(919) 303-6906

This message was sent by KnowWho, as a service provider only, on behalf of the individual noted in the sender information.

From: Peter Lourekas (pixbill@aol.com) Sent You a Personal Message
To: [daq.NC_VWGrants](#)
Subject: [External] Use Volkswagen funds to electrify NC transportation
Date: Thursday, December 07, 2017 2:19:34 PM

CAUTION: External email. Do not click links or open attachments unless verified. Send all suspicious email as an attachment to report.spam@nc.gov.

Dear Division of Air Quality,

I am writing to urge DEQ to wisely invest the \$92 million in Volkswagen settlement funds in electric vehicles and infrastructure. Taking advantage of these funds to jumpstart the electrification of North Carolina's transportation sector will mean less money sent out of state for petroleum, more in-state jobs, and cleaner air.

Specifically, I recommend that DEQ allocate the maximum allowable amount (15%) of the funds for electric vehicle charging infrastructure and installations. And I encourage DEQ to prioritize electric vehicles and buses for replacement whenever possible with the other 85% of the settlement funds. Doing so will maximize the local economic impact and the reduction of air pollution.

I encourage you to not use the funding for natural gas, propane or diesel vehicles. Further dependence on fossil fuels means more pollution. Only a transition to electric vehicles and investment in EV infrastructure will put us on the road to a 100% clean transportation sector in North Carolina.

Sincerely,

Peter Lourekas
PO Box 18738
Peter, NC 28814
pixbill@aol.com
(828) 772-9320

This message was sent by KnowWho, as a service provider only, on behalf of the individual noted in the sender information.

From: Rama Darbha (rama.h.darbha@gmail.com) Sent You a Personal Message
To: [daq.NC_VWGrants](#)
Subject: [External] Use Volkswagen funds to electrify NC transportation
Date: Thursday, December 07, 2017 1:43:24 PM

CAUTION: External email. Do not click links or open attachments unless verified. Send all suspicious email as an attachment to report.spam@nc.gov.

Dear Division of Air Quality,

I am writing to urge DEQ to wisely invest the \$92 million in Volkswagen settlement funds in electric vehicles and infrastructure. Taking advantage of these funds to jumpstart the electrification of North Carolina's transportation sector will mean less money sent out of state for petroleum, more in-state jobs, and cleaner air.

Specifically, I recommend that DEQ allocate the maximum allowable amount (15%) of the funds for electric vehicle charging infrastructure and installations. And I encourage DEQ to prioritize electric vehicles and buses for replacement whenever possible with the other 85% of the settlement funds. Doing so will maximize the local economic impact and the reduction of air pollution.

I encourage you to not use the funding for natural gas, propane or diesel vehicles. Further dependence on fossil fuels means more pollution. Only a transition to electric vehicles and investment in EV infrastructure will put us on the road to a 100% clean transportation sector in North Carolina.

Sincerely,

Rama Darbha
8440 Stone Mason Dr
Raleigh, NC 27613
rama.h.darbha@gmail.com
(919) 410-7262

This message was sent by KnowWho, as a service provider only, on behalf of the individual noted in the sender information.

From: Zoe nicholie (nicholiezoe01@gmail.com) Sent You a Personal Message
To: [daq.NC_VWGrants](#)
Subject: [External] Use Volkswagen funds to electrify NC transportation
Date: Thursday, December 07, 2017 1:28:41 PM

CAUTION: External email. Do not click links or open attachments unless verified. Send all suspicious email as an attachment to report.spam@nc.gov.

Dear Division of Air Quality,

I am writing to urge DEQ to wisely invest the \$92 million in Volkswagen settlement funds in electric vehicles and infrastructure. Taking advantage of these funds to jumpstart the electrification of North Carolina's transportation sector will mean less money sent out of state for petroleum, more in-state jobs, and cleaner air.

Specifically, I recommend that DEQ allocate the maximum allowable amount (15%) of the funds for electric vehicle charging infrastructure and installations. And I encourage DEQ to prioritize electric vehicles and buses for replacement whenever possible with the other 85% of the settlement funds. Doing so will maximize the local economic impact and the reduction of air pollution.

I encourage you to not use the funding for natural gas, propane or diesel vehicles. Further dependence on fossil fuels means more pollution. Only a transition to electric vehicles and investment in EV infrastructure will put us on the road to a 100% clean transportation sector in North Carolina.

Sincerely,

Zoe nicholie
96 Knauth Rd
Asheville, NC 28805
nicholiezoe01@gmail.com
(828) 505-1284

This message was sent by KnowWho, as a service provider only, on behalf of the individual noted in the sender information.

From: Robert James (rejames42251@charter.net) Sent You a Personal Message
To: [daq.NC_VWGrants](#)
Subject: [External] Use Volkswagen funds to electrify NC transportation
Date: Thursday, December 07, 2017 12:54:40 PM

CAUTION: External email. Do not click links or open attachments unless verified. Send all suspicious email as an attachment to report.spam@nc.gov.

Dear Division of Air Quality,

I am writing to urge DEQ to wisely invest the \$92 million in Volkswagen settlement funds in electric vehicles and infrastructure. Taking advantage of these funds to jumpstart the electrification of North Carolina's transportation sector will mean less money sent out of state for petroleum, more in-state jobs, and cleaner air.

Specifically, I recommend that DEQ allocate the maximum allowable amount (15%) of the funds for electric vehicle charging infrastructure and installations. And I encourage DEQ to prioritize electric vehicles and buses for replacement whenever possible with the other 85% of the settlement funds. Doing so will maximize the local economic impact and the reduction of air pollution.

I encourage you to not use the funding for natural gas, propane or diesel vehicles. Further dependence on fossil fuels means more pollution. Only a transition to electric vehicles and investment in EV infrastructure will put us on the road to a 100% clean transportation sector in North Carolina.

Sincerely,

Robert James
2 Ayr Ct
Arden, NC 28704
rejames42251@charter.net
(865) 789-0348

This message was sent by KnowWho, as a service provider only, on behalf of the individual noted in the sender information.

From: Steve Wood (sfwood@live.unc.edu) Sent You a Personal Message
To: [daq.NC_VWGrants](#)
Subject: [External] Use Volkswagen funds to electrify NC transportation
Date: Thursday, December 07, 2017 12:45:32 PM

CAUTION: External email. Do not click links or open attachments unless verified. Send all suspicious email as an attachment to report.spam@nc.gov.

Dear Division of Air Quality,

I am writing to urge DEQ to wisely invest the \$92 million in Volkswagen settlement funds in electric vehicles and infrastructure. Taking advantage of these funds to jumpstart the electrification of North Carolina's transportation sector will mean less money sent out of state for petroleum, more in-state jobs, and cleaner air.

Specifically, I recommend that DEQ allocate the maximum allowable amount (15%) of the funds for electric vehicle charging infrastructure and installations. And I encourage DEQ to prioritize electric vehicles and buses for replacement whenever possible with the other 85% of the settlement funds. Doing so will maximize the local economic impact and the reduction of air pollution.

I encourage you to not use the funding for natural gas, propane or diesel vehicles. Further dependence on fossil fuels means more pollution. Only a transition to electric vehicles and investment in EV infrastructure will put us on the road to a 100% clean transportation sector in North Carolina.

Sincerely,

Steve Wood
211 pritchard ave
Chapel Hill, NC 27516
sfwood@live.unc.edu
(615) 818-4025

This message was sent by KnowWho, as a service provider only, on behalf of the individual noted in the sender information.

From: ERIC CONKLIN (eec.egc@gmail.com) Sent You a Personal Message
To: [daq.NC_VWGrants](#)
Subject: [External] Use Volkswagen funds to electrify NC transportation
Date: Thursday, December 07, 2017 12:44:54 PM

CAUTION: External email. Do not click links or open attachments unless verified. Send all suspicious email as an attachment to report.spam@nc.gov.

Dear Division of Air Quality,

I am writing to urge DEQ to wisely invest the \$92 million in Volkswagen settlement funds in electric vehicles and infrastructure. Taking advantage of these funds to jumpstart the electrification of North Carolina's transportation sector will mean less money sent out of state for petroleum, more in-state jobs, and cleaner air.

Specifically, I recommend that DEQ allocate the maximum allowable amount (15%) of the funds for electric vehicle charging infrastructure and installations. And I encourage DEQ to prioritize electric vehicles and buses for replacement whenever possible with the other 85% of the settlement funds. Doing so will maximize the local economic impact and the reduction of air pollution.

I encourage you to not use the funding for natural gas, propane or diesel vehicles. Further dependence on fossil fuels means more pollution. Only a transition to electric vehicles and investment in EV infrastructure will put us on the road to a 100% clean transportation sector in North Carolina.

Sincerely,

ERIC CONKLIN
7025 OLD FIELD RD
WILMINGTON, NC 28411
eec.egc@gmail.com
(910) 616-1196

This message was sent by KnowWho, as a service provider only, on behalf of the individual noted in the sender information.

From: Kirk Pappan (kirk.pappan@gmail.com) Sent You a Personal Message
To: [daq.NC_VWGrants](#)
Subject: [External] Use Volkswagen funds to electrify NC transportation
Date: Thursday, December 07, 2017 12:44:53 PM

CAUTION: External email. Do not click links or open attachments unless verified. Send all suspicious email as an attachment to report.spam@nc.gov.

Dear Division of Air Quality,

I am writing to urge DEQ to wisely invest the \$92 million in Volkswagen settlement funds in electric vehicles and infrastructure. Taking advantage of these funds to jumpstart the electrification of North Carolina's transportation sector will mean less money sent out of state for petroleum, more in-state jobs, and cleaner air.

Specifically, I recommend that DEQ allocate the maximum allowable amount (15%) of the funds for electric vehicle charging infrastructure and installations. And I encourage DEQ to prioritize electric vehicles and buses for replacement whenever possible with the other 85% of the settlement funds. Doing so will maximize the local economic impact and the reduction of air pollution.

I encourage you to not use the funding for natural gas, propane or diesel vehicles. Further dependence on fossil fuels means more pollution. Only a transition to electric vehicles and investment in EV infrastructure will put us on the road to a 100% clean transportation sector in North Carolina.

Sincerely,

Kirk Pappan
6015 Laws Farm Road
Rougemont, NC 27572
kirk.pappan@gmail.com
(919) 245-0891

This message was sent by KnowWho, as a service provider only, on behalf of the individual noted in the sender information.

From: Michele Hickman (mhickman1120@aol.com) Sent You a Personal Message
To: [daq.NC_VWGrants](#)
Subject: [External] Use Volkswagen funds to electrify NC transportation
Date: Thursday, December 07, 2017 12:26:47 PM

CAUTION: External email. Do not click links or open attachments unless verified. Send all suspicious email as an attachment to report.spam@nc.gov.

Dear Division of Air Quality,

I am writing to urge DEQ to wisely invest the \$92 million in Volkswagen settlement funds in electric vehicles and infrastructure. Taking advantage of these funds to jumpstart the electrification of North Carolina's transportation sector will mean less money sent out of state for petroleum, more in-state jobs, and cleaner air.

Specifically, I recommend that DEQ allocate the maximum allowable amount (15%) of the funds for electric vehicle charging infrastructure and installations. And I encourage DEQ to prioritize electric vehicles and buses for replacement whenever possible with the other 85% of the settlement funds. Doing so will maximize the local economic impact and the reduction of air pollution.

I encourage you to not use the funding for natural gas, propane or diesel vehicles. Further dependence on fossil fuels means more pollution. Only a transition to electric vehicles and investment in EV infrastructure will put us on the road to a 100% clean transportation sector in North Carolina.

Sincerely,

Michele Hickman
341 Lafayette Street
Wilmington, NC 28411
mhickman1120@aol.com
(910) 512-3869

This message was sent by KnowWho, as a service provider only, on behalf of the individual noted in the sender information.

From: Rosemary Sweatt (rosieb04@gmail.com) Sent You a Personal Message
To: [daq.NC_VWGrants](#)
Subject: [External] Use Volkswagen funds to electrify NC transportation
Date: Thursday, December 07, 2017 12:20:37 PM

CAUTION: External email. Do not click links or open attachments unless verified. Send all suspicious email as an attachment to report.spam@nc.gov.

Dear Division of Air Quality,

I am writing to urge DEQ to wisely invest the \$92 million in Volkswagen settlement funds in electric vehicles and infrastructure. Taking advantage of these funds to jumpstart the electrification of North Carolina's transportation sector will mean less money sent out of state for petroleum, more in-state jobs, and cleaner air.

Specifically, I recommend that DEQ allocate the maximum allowable amount (15%) of the funds for electric vehicle charging infrastructure and installations. And I encourage DEQ to prioritize electric vehicles and buses for replacement whenever possible with the other 85% of the settlement funds. Doing so will maximize the local economic impact and the reduction of air pollution.

I encourage you to not use the funding for natural gas, propane or diesel vehicles. Further dependence on fossil fuels means more pollution. Only a transition to electric vehicles and investment in EV infrastructure will put us on the road to a 100% clean transportation sector in North Carolina.

Sincerely,

Rosemary Sweatt
1025 N Maple Ave
Cookeville, TN 38501
rosieb04@gmail.com
(615) 293-5891

This message was sent by KnowWho, as a service provider only, on behalf of the individual noted in the sender information.

From: Carol Trevey (caroltrevey@charter.net) Sent You a Personal Message
To: [daq.NC_VWGrants](#)
Subject: [External] Use Volkswagen funds to electrify NC transportation
Date: Thursday, December 07, 2017 11:54:17 AM

CAUTION: External email. Do not click links or open attachments unless verified. Send all suspicious email as an attachment to report.spam@nc.gov.

Dear Division of Air Quality,

I am writing to urge DEQ to wisely invest the \$92 million in Volkswagen settlement funds in electric vehicles and infrastructure. Taking advantage of these funds to jumpstart the electrification of North Carolina's transportation sector will mean less money sent out of state for petroleum, more in-state jobs, and cleaner air.

Specifically, I recommend that DEQ allocate the maximum allowable amount (15%) of the funds for electric vehicle charging infrastructure and installations. And I encourage DEQ to prioritize electric vehicles and buses for replacement whenever possible with the other 85% of the settlement funds. Doing so will maximize the local economic impact and the reduction of air pollution.

I encourage you to not use the funding for natural gas, propane or diesel vehicles. Further dependence on fossil fuels means more pollution. Only a transition to electric vehicles and investment in EV infrastructure will put us on the road to a 100% clean transportation sector in North Carolina.

Sincerely,

Carol Trevey
135 Sherman Lakes Drive
Fuquay Varina, NC 27526
caroltrevey@charter.net
(919) 753-4463

This message was sent by KnowWho, as a service provider only, on behalf of the individual noted in the sender information.

From: Leslie Hawkins (saalem1200@att.net) Sent You a Personal Message
To: daq.NC_VWGrants
Subject: [External] Use Volkswagen funds to electrify NC transportation
Date: Thursday, December 07, 2017 11:48:18 AM

CAUTION: External email. Do not click links or open attachments unless verified. Send all suspicious email as an attachment to report.spam@nc.gov.

Dear Division of Air Quality,

I am writing to urge DEQ to wisely invest the \$92 million in Volkswagen settlement funds in electric vehicles and infrastructure. Taking advantage of these funds to jumpstart the electrification of North Carolina's transportation sector will mean less money sent out of state for petroleum, more in-state jobs, and cleaner air.

Specifically, I recommend that DEQ allocate the maximum allowable amount (15%) of the funds for electric vehicle charging infrastructure and installations. And I encourage DEQ to prioritize electric vehicles and buses for replacement whenever possible with the other 85% of the settlement funds. Doing so will maximize the local economic impact and the reduction of air pollution.

I encourage you to not use the funding for natural gas, propane or diesel vehicles. Further dependence on fossil fuels means more pollution. Only a transition to electric vehicles and investment in EV infrastructure will put us on the road to a 100% clean transportation sector in North Carolina.

Sincerely,

Leslie Hawkins
6017 Allington Ct
Winston-Salem, NC 27104
saalem1200@att.net
(510) 520-2368

This message was sent by KnowWho, as a service provider only, on behalf of the individual noted in the sender information.

From: Derek Chase (dchase6507@gmail.com) Sent You a Personal Message
To: [daq.NC_VWGrants](#)
Subject: [External] Use Volkswagen funds to electrify NC transportation
Date: Thursday, December 07, 2017 11:34:18 AM

CAUTION: External email. Do not click links or open attachments unless verified. Send all suspicious email as an attachment to report.spam@nc.gov.

Dear Division of Air Quality,

I am writing to urge DEQ to wisely invest the \$92 million in Volkswagen settlement funds in electric vehicles and infrastructure. Taking advantage of these funds to jumpstart the electrification of North Carolina's transportation sector will mean less money sent out of state for petroleum, more in-state jobs, and cleaner air.

Specifically, I recommend that DEQ allocate the maximum allowable amount (15%) of the funds for electric vehicle charging infrastructure and installations. And I encourage DEQ to prioritize electric vehicles and buses for replacement whenever possible with the other 85% of the settlement funds. Doing so will maximize the local economic impact and the reduction of air pollution.

I encourage you to not use the funding for natural gas, propane or diesel vehicles. Further dependence on fossil fuels means more pollution. Only a transition to electric vehicles and investment in EV infrastructure will put us on the road to a 100% clean transportation sector in North Carolina.

Sincerely,

Derek Chase
1910 20th Ave. Dr. NE, Apt. 111
Hickory, NC 28601
dchase6507@gmail.com
(828) 308-6150

This message was sent by KnowWho, as a service provider only, on behalf of the individual noted in the sender information.

From: wells eddleman (none@email.com) Sent You a Personal Message
To: [daq.NC_VWGrants](#)
Subject: [External] Use Volkswagen funds to electrify NC transportation
Date: Thursday, December 07, 2017 11:28:13 AM

CAUTION: External email. Do not click links or open attachments unless verified. Send all suspicious email as an attachment to report.spam@nc.gov.

Dear Division of Air Quality,

I am writing to urge DEQ to wisely invest the \$92 million in Volkswagen settlement funds in electric vehicles and infrastructure. Taking advantage of these funds to jumpstart the electrification of North Carolina's transportation sector will mean less money sent out of state for petroleum, more in-state jobs, and cleaner air.

Specifically, I recommend that DEQ allocate the maximum allowable amount (15%) of the funds for electric vehicle charging infrastructure and installations. And I encourage DEQ to prioritize electric vehicles and buses for replacement whenever possible with the other 85% of the settlement funds. Doing so will maximize the local economic impact and the reduction of air pollution.

I encourage you to not use the funding for natural gas, propane or diesel vehicles. Further dependence on fossil fuels means more pollution. Only a transition to electric vehicles and investment in EV infrastructure will put us on the road to a 100% clean transportation sector in North Carolina.

Sincerely,

wells eddleman
811 Yancey Street
Durham, NC 27701
none@email.com
(919) 688-3016

This message was sent by KnowWho, as a service provider only, on behalf of the individual noted in the sender information.

From: Sydney Copeland (sydneycopeland96@gmail.com) Sent You a Personal Message
To: [daq.NC_VWGrants](#)
Subject: [External] Use Volkswagen funds to electrify NC transportation
Date: Thursday, December 07, 2017 11:15:59 AM

CAUTION: External email. Do not click links or open attachments unless verified. Send all suspicious email as an attachment to report.spam@nc.gov.

Dear Division of Air Quality,

I am writing to urge DEQ to wisely invest the \$92 million in Volkswagen settlement funds in electric vehicles and infrastructure. Taking advantage of these funds to jumpstart the electrification of North Carolina's transportation sector will mean less money sent out of state for petroleum, more in-state jobs, and cleaner air.

Specifically, I recommend that DEQ allocate the maximum allowable amount (15%) of the funds for electric vehicle charging infrastructure and installations. And I encourage DEQ to prioritize electric vehicles and buses for replacement whenever possible with the other 85% of the settlement funds. Doing so will maximize the local economic impact and the reduction of air pollution.

I encourage you to not use the funding for natural gas, propane or diesel vehicles. Further dependence on fossil fuels means more pollution. Only a transition to electric vehicles and investment in EV infrastructure will put us on the road to a 100% clean transportation sector in North Carolina.

Sincerely,

Sydney Copeland
7030 daerwood pl
Charlotte, NC 28215
sydneycopeland96@gmail.com
(704) 241-8457

This message was sent by KnowWho, as a service provider only, on behalf of the individual noted in the sender information.

From: Lois Heintz (725efdaf@opayq.com) Sent You a Personal Message
To: [daq.NC_VWGrants](#)
Subject: [External] Use Volkswagen funds to electrify NC transportation
Date: Thursday, December 07, 2017 11:15:39 AM

CAUTION: External email. Do not click links or open attachments unless verified. Send all suspicious email as an attachment to report.spam@nc.gov.

Dear Division of Air Quality,

I am writing to urge DEQ to wisely invest the \$92 million in Volkswagen settlement funds in electric vehicles and infrastructure. Taking advantage of these funds to jumpstart the electrification of North Carolina's transportation sector will mean less money sent out of state for petroleum, more in-state jobs, and cleaner air.

Specifically, I recommend that DEQ allocate the maximum allowable amount (15%) of the funds for electric vehicle charging infrastructure and installations. And I encourage DEQ to prioritize electric vehicles and buses for replacement whenever possible with the other 85% of the settlement funds. Doing so will maximize the local economic impact and the reduction of air pollution.

I encourage you to not use the funding for natural gas, propane or diesel vehicles. Further dependence on fossil fuels means more pollution. Only a transition to electric vehicles and investment in EV infrastructure will put us on the road to a 100% clean transportation sector in North Carolina.

Sincerely,

Lois Heintz
81 Locust St
Blk Mt, NC 28711
725efdaf@opayq.com
(828) 357-5152

This message was sent by KnowWho, as a service provider only, on behalf of the individual noted in the sender information.

From: Sally Buchanan (sallyperio@bellsouth.net) Sent You a Personal Message
To: [daq.NC_VWGrants](#)
Subject: [External] Use Volkswagen funds to electrify NC transportation
Date: Thursday, December 07, 2017 11:14:39 AM

CAUTION: External email. Do not click links or open attachments unless verified. Send all suspicious email as an attachment to report.spam@nc.gov.

Dear Division of Air Quality,

I am writing to urge DEQ to wisely invest the \$92 million in Volkswagen settlement funds in electric vehicles and infrastructure. Taking advantage of these funds to jumpstart the electrification of North Carolina's transportation sector will mean less money sent out of state for petroleum, more in-state jobs, and cleaner air.

Specifically, I recommend that DEQ allocate the maximum allowable amount (15%) of the funds for electric vehicle charging infrastructure and installations. And I encourage DEQ to prioritize electric vehicles and buses for replacement whenever possible with the other 85% of the settlement funds. Doing so will maximize the local economic impact and the reduction of air pollution.

I encourage you to not use the funding for natural gas, propane or diesel vehicles. Further dependence on fossil fuels means more pollution. Only a transition to electric vehicles and investment in EV infrastructure will put us on the road to a 100% clean transportation sector in North Carolina.

Sincerely,

Sally Buchanan
904 Caswell Beach Road
Caswell Beach, NC 28465
sallyperio@bellsouth.net
(910) 269-8969

This message was sent by KnowWho, as a service provider only, on behalf of the individual noted in the sender information.

From: Eric LANIER (ericlanier@yahoo.com) Sent You a Personal Message
To: [daq.NC_VWGrants](#)
Subject: [External] Use Volkswagen funds to electrify NC transportation
Date: Thursday, December 07, 2017 10:54:35 AM

CAUTION: External email. Do not click links or open attachments unless verified. Send all suspicious email as an attachment to report.spam@nc.gov.

Dear Division of Air Quality,

I am writing to urge DEQ to wisely invest the \$92 million in Volkswagen settlement funds in electric vehicles and infrastructure. Taking advantage of these funds to jumpstart the electrification of North Carolina's transportation sector will mean less money sent out of state for petroleum, more in-state jobs, and cleaner air.

Specifically, I recommend that DEQ allocate the maximum allowable amount (15%) of the funds for electric vehicle charging infrastructure and installations. And I encourage DEQ to prioritize electric vehicles and buses for replacement whenever possible with the other 85% of the settlement funds. Doing so will maximize the local economic impact and the reduction of air pollution.

I encourage you to not use the funding for natural gas, propane or diesel vehicles. Further dependence on fossil fuels means more pollution. Only a transition to electric vehicles and investment in EV infrastructure will put us on the road to a 100% clean transportation sector in North Carolina.

Sincerely,

Eric LANIER
8812 Statesman Dr
Mint Hill, NC 28227
ericlanier@yahoo.com
(704) 545-3160

This message was sent by KnowWho, as a service provider only, on behalf of the individual noted in the sender information.

From: Jason McCammon (brewmancer@gmail.com) Sent You a Personal Message
To: [daq.NC_VWGrants](#)
Subject: [External] Use Volkswagen funds to electrify NC transportation
Date: Thursday, December 07, 2017 10:20:51 AM

CAUTION: External email. Do not click links or open attachments unless verified. Send all suspicious email as an attachment to report.spam@nc.gov.

Dear Division of Air Quality,

I am writing to urge DEQ to wisely invest the \$92 million in Volkswagen settlement funds in electric vehicles and infrastructure. Taking advantage of these funds to jumpstart the electrification of North Carolina's transportation sector will mean less money sent out of state for petroleum, more in-state jobs, and cleaner air.

Specifically, I recommend that DEQ allocate the maximum allowable amount (15%) of the funds for electric vehicle charging infrastructure and installations. And I encourage DEQ to prioritize electric vehicles and buses for replacement whenever possible with the other 85% of the settlement funds. Doing so will maximize the local economic impact and the reduction of air pollution.

I encourage you to not use the funding for natural gas, propane or diesel vehicles. Further dependence on fossil fuels means more pollution. Only a transition to electric vehicles and investment in EV infrastructure will put us on the road to a 100% clean transportation sector in North Carolina.

Sincerely,

Jason McCammon
90 Nolte Way
Saluda, NC 28773
brewmancer@gmail.com
(828) 691-8202

This message was sent by KnowWho, as a service provider only, on behalf of the individual noted in the sender information.

From: Kate Capehart (becomingfuriosa@gmail.com) Sent You a Personal Message
To: [daq.NC_VWGrants](#)
Subject: [External] Use Volkswagen funds to electrify NC transportation
Date: Thursday, December 07, 2017 10:15:14 AM

CAUTION: External email. Do not click links or open attachments unless verified. Send all suspicious email as an attachment to report.spam@nc.gov.

Dear Division of Air Quality,

I am writing to urge DEQ to wisely invest the \$92 million in Volkswagen settlement funds in electric vehicles and infrastructure. Taking advantage of these funds to jumpstart the electrification of North Carolina's transportation sector will mean less money sent out of state for petroleum, more in-state jobs, and cleaner air.

Specifically, I recommend that DEQ allocate the maximum allowable amount (15%) of the funds for electric vehicle charging infrastructure and installations. And I encourage DEQ to prioritize electric vehicles and buses for replacement whenever possible with the other 85% of the settlement funds. Doing so will maximize the local economic impact and the reduction of air pollution.

I encourage you to not use the funding for natural gas, propane or diesel vehicles. Further dependence on fossil fuels means more pollution. Only a transition to electric vehicles and investment in EV infrastructure will put us on the road to a 100% clean transportation sector in North Carolina.

Sincerely,

Kate Capehart
900 Lydias Way
Durham, NC 27713
becomingfuriosa@gmail.com
(704) 747-9994

This message was sent by KnowWho, as a service provider only, on behalf of the individual noted in the sender information.

From: JAMAL MOULINE (jmouline@zoho.com) Sent You a Personal Message
To: [daq.NC_VWGrants](#)
Subject: [External] Use Volkswagen funds to electrify NC transportation
Date: Thursday, December 07, 2017 9:56:21 AM

CAUTION: External email. Do not click links or open attachments unless verified. Send all suspicious email as an attachment to report.spam@nc.gov.

Dear Division of Air Quality,

I am writing to urge DEQ to wisely invest the \$92 million in Volkswagen settlement funds in electric vehicles and infrastructure. Taking advantage of these funds to jumpstart the electrification of North Carolina's transportation sector will mean less money sent out of state for petroleum, more in-state jobs, and cleaner air.

Specifically, I recommend that DEQ allocate the maximum allowable amount (15%) of the funds for electric vehicle charging infrastructure and installations. And I encourage DEQ to prioritize electric vehicles and buses for replacement whenever possible with the other 85% of the settlement funds. Doing so will maximize the local economic impact and the reduction of air pollution.

I encourage you to not use the funding for natural gas, propane or diesel vehicles. Further dependence on fossil fuels means more pollution. Only a transition to electric vehicles and investment in EV infrastructure will put us on the road to a 100% clean transportation sector in North Carolina.

Sincerely,

JAMAL MOULINE
40 James St
Apex, NC 27502
jmouline@zoho.com
(919) 794-3678

This message was sent by KnowWho, as a service provider only, on behalf of the individual noted in the sender information.

From: Robert Golden (robert.golden@plattsburgh.edu) Sent You a Personal Message
To: [daq.NC_VWGrants](#)
Subject: [External] Use Volkswagen funds to electrify NC transportation
Date: Thursday, December 07, 2017 9:43:09 AM

CAUTION: External email. Do not click links or open attachments unless verified. Send all suspicious email as an attachment to report.spam@nc.gov.

Dear Division of Air Quality,

I am writing to urge DEQ to wisely invest the \$92 million in Volkswagen settlement funds in electric vehicles and infrastructure. Taking advantage of these funds to jumpstart the electrification of North Carolina's transportation sector will mean less money sent out of state for petroleum, more in-state jobs, and cleaner air.

Specifically, I recommend that DEQ allocate the maximum allowable amount (15%) of the funds for electric vehicle charging infrastructure and installations. And I encourage DEQ to prioritize electric vehicles and buses for replacement whenever possible with the other 85% of the settlement funds. Doing so will maximize the local economic impact and the reduction of air pollution.

I encourage you to not use the funding for natural gas, propane or diesel vehicles. Further dependence on fossil fuels means more pollution. Only a transition to electric vehicles and investment in EV infrastructure will put us on the road to a 100% clean transportation sector in North Carolina.

Sincerely,

Robert Golden
494 Alexis Drive
NEW BERN, NC 28562
robert.golden@plattsburgh.edu
(518) 955-6242

This message was sent by KnowWho, as a service provider only, on behalf of the individual noted in the sender information.

From: Joel Marchesoni (jmarshesoni@gmail.com) Sent You a Personal Message
To: [daq.NC_VWGrants](#)
Subject: [External] Use Volkswagen funds to electrify NC transportation
Date: Thursday, December 07, 2017 9:16:06 AM

CAUTION: External email. Do not click links or open attachments unless verified. Send all suspicious email as an attachment to report.spam@nc.gov.

Dear Division of Air Quality,

I am writing to urge DEQ to wisely invest the \$92 million in Volkswagen settlement funds in electric vehicles and infrastructure. Taking advantage of these funds to jumpstart the electrification of North Carolina's transportation sector will mean less money sent out of state for petroleum, more in-state jobs, and cleaner air.

Specifically, I recommend that DEQ allocate the maximum allowable amount (15%) of the funds for electric vehicle charging infrastructure and installations. And I encourage DEQ to prioritize electric vehicles and buses for replacement whenever possible with the other 85% of the settlement funds. Doing so will maximize the local economic impact and the reduction of air pollution.

I encourage you to not use the funding for natural gas, propane or diesel vehicles. Further dependence on fossil fuels means more pollution. Only a transition to electric vehicles and investment in EV infrastructure will put us on the road to a 100% clean transportation sector in North Carolina.

Sincerely,

Joel Marchesoni
48 Running Water Circle
Sylva, NC 28779
jmarshesoni@gmail.com
(828) 507-7200

This message was sent by KnowWho, as a service provider only, on behalf of the individual noted in the sender information.

From: Katharine DeVilbiss (katharine.devilbiss@gmail.com) Sent You a Personal Message
To: [daq.NC_VWGrants](#)
Subject: [External] Use Volkswagen funds to electrify NC transportation
Date: Thursday, December 07, 2017 9:06:33 AM

CAUTION: External email. Do not click links or open attachments unless verified. Send all suspicious email as an attachment to report.spam@nc.gov.

Dear Division of Air Quality,

I am writing to urge DEQ to wisely invest the \$92 million in Volkswagen settlement funds in electric vehicles and infrastructure. Taking advantage of these funds to jumpstart the electrification of North Carolina's transportation sector will mean less money sent out of state for petroleum, more in-state jobs, and cleaner air.

Specifically, I recommend that DEQ allocate the maximum allowable amount (15%) of the funds for electric vehicle charging infrastructure and installations. And I encourage DEQ to prioritize electric vehicles and buses for replacement whenever possible with the other 85% of the settlement funds. Doing so will maximize the local economic impact and the reduction of air pollution.

I encourage you to not use the funding for natural gas, propane or diesel vehicles. Further dependence on fossil fuels means more pollution. Only a transition to electric vehicles and investment in EV infrastructure will put us on the road to a 100% clean transportation sector in North Carolina.

Sincerely,

Katharine DeVilbiss
2509 Fitzgerald Dr.
Raleigh, NC 27610
katharine.devilbiss@gmail.com
(302) 381-9063

This message was sent by KnowWho, as a service provider only, on behalf of the individual noted in the sender information.

From: Janet Hosey (nchosey@intrstar.net) Sent You a Personal Message
To: [daq.NC_VWGrants](#)
Subject: [External] Use Volkswagen funds to electrify NC transportation
Date: Thursday, December 07, 2017 8:15:22 AM

CAUTION: External email. Do not click links or open attachments unless verified. Send all suspicious email as an attachment to report.spam@nc.gov.

Dear Division of Air Quality,

I am writing to urge DEQ to wisely invest the \$92 million in Volkswagen settlement funds in electric vehicles and infrastructure. Taking advantage of these funds to jumpstart the electrification of North Carolina's transportation sector will mean less money sent out of state for petroleum, more in-state jobs, and cleaner air.

Specifically, I recommend that DEQ allocate the maximum allowable amount (15%) of the funds for electric vehicle charging infrastructure and installations. And I encourage DEQ to prioritize electric vehicles and buses for replacement whenever possible with the other 85% of the settlement funds. Doing so will maximize the local economic impact and the reduction of air pollution.

I encourage you to not use the funding for natural gas, propane or diesel vehicles. Further dependence on fossil fuels means more pollution. Only a transition to electric vehicles and investment in EV infrastructure will put us on the road to a 100% clean transportation sector in North Carolina.

Sincerely,

Janet Hosey
265 Barnhill Rd.
Ivanhoe, NC 28447
nchosey@intrstar.net
(910) 532-2228

This message was sent by KnowWho, as a service provider only, on behalf of the individual noted in the sender information.

From: Sarah Simpson (sarah.simpson@goddard.edu) Sent You a Personal Message
To: [daq.NC_VWGrants](#)
Subject: [External] Use Volkswagen funds to electrify NC transportation
Date: Thursday, December 07, 2017 8:09:41 AM

CAUTION: External email. Do not click links or open attachments unless verified. Send all suspicious email as an attachment to report.spam@nc.gov.

Dear Division of Air Quality,

I am writing to urge DEQ to wisely invest the \$92 million in Volkswagen settlement funds in electric vehicles and infrastructure. Taking advantage of these funds to jumpstart the electrification of North Carolina's transportation sector will mean less money sent out of state for petroleum, more in-state jobs, and cleaner air.

Specifically, I recommend that DEQ allocate the maximum allowable amount (15%) of the funds for electric vehicle charging infrastructure and installations. And I encourage DEQ to prioritize electric vehicles and buses for replacement whenever possible with the other 85% of the settlement funds. Doing so will maximize the local economic impact and the reduction of air pollution.

I encourage you to not use the funding for natural gas, propane or diesel vehicles. Further dependence on fossil fuels means more pollution. Only a transition to electric vehicles and investment in EV infrastructure will put us on the road to a 100% clean transportation sector in North Carolina.

Sincerely,

Sarah Simpson
241 Meadow Lane
Leicester, NC 28748
sarah.simpson@goddard.edu
(919) 805-4096

This message was sent by KnowWho, as a service provider only, on behalf of the individual noted in the sender information.

From: Mary Stone (freddyduck@gmail.com) Sent You a Personal Message
To: [daq.NC_VWGrants](#)
Subject: [External] Use Volkswagen funds to electrify NC transportation
Date: Thursday, December 07, 2017 7:58:19 AM

CAUTION: External email. Do not click links or open attachments unless verified. Send all suspicious email as an attachment to report.spam@nc.gov.

Dear Division of Air Quality,

I am writing to urge DEQ to wisely invest the \$92 million in Volkswagen settlement funds in electric vehicles and infrastructure. Taking advantage of these funds to jumpstart the electrification of North Carolina's transportation sector will mean less money sent out of state for petroleum, more in-state jobs, and cleaner air.

Specifically, I recommend that DEQ allocate the maximum allowable amount (15%) of the funds for electric vehicle charging infrastructure and installations. And I encourage DEQ to prioritize electric vehicles and buses for replacement whenever possible with the other 85% of the settlement funds. Doing so will maximize the local economic impact and the reduction of air pollution.

I encourage you to not use the funding for natural gas, propane or diesel vehicles. Further dependence on fossil fuels means more pollution. Only a transition to electric vehicles and investment in EV infrastructure will put us on the road to a 100% clean transportation sector in North Carolina.

Sincerely,

Mary Stone
500 Audubon Dr.
Mary, NC 28571
freddyduck@gmail.com
(804) 814-3918

This message was sent by KnowWho, as a service provider only, on behalf of the individual noted in the sender information.

From: Nathaniel Grubbs (dear_sherlock@hotmail.com) Sent You a Personal Message
To: [daq.NC_VWGrants](#)
Subject: [External] Use Volkswagen funds to electrify NC transportation
Date: Thursday, December 07, 2017 7:34:52 AM

CAUTION: External email. Do not click links or open attachments unless verified. Send all suspicious email as an attachment to report.spam@nc.gov.

Dear Division of Air Quality,

I am writing to urge DEQ to wisely invest the \$92 million in Volkswagen settlement funds in electric vehicles and infrastructure. Taking advantage of these funds to jumpstart the electrification of North Carolina's transportation sector will mean less money sent out of state for petroleum, more in-state jobs, and cleaner air.

Specifically, I recommend that DEQ allocate the maximum allowable amount (15%) of the funds for electric vehicle charging infrastructure and installations. And I encourage DEQ to prioritize electric vehicles and buses for replacement whenever possible with the other 85% of the settlement funds. Doing so will maximize the local economic impact and the reduction of air pollution.

I encourage you to not use the funding for natural gas, propane or diesel vehicles. Further dependence on fossil fuels means more pollution. Only a transition to electric vehicles and investment in EV infrastructure will put us on the road to a 100% clean transportation sector in North Carolina.

Sincerely,

Nathaniel Grubbs
3537 Sugar Tree Pl
Durham, NC 27713
dear_sherlock@hotmail.com
(252) 267-3074

This message was sent by KnowWho, as a service provider only, on behalf of the individual noted in the sender information.

From: Richard Martula (drdick61@gmail.com) Sent You a Personal Message
To: daq.NC_VWGrants
Subject: [External] Use Volkswagen funds to electrify NC transportation
Date: Thursday, December 07, 2017 7:12:13 AM

CAUTION: External email. Do not click links or open attachments unless verified. Send all suspicious email as an attachment to report.spam@nc.gov.

Dear Division of Air Quality,

I am writing to urge DEQ to wisely invest the \$92 million in Volkswagen settlement funds in electric vehicles and infrastructure. Taking advantage of these funds to jumpstart the electrification of North Carolina's transportation sector will mean less money sent out of state for petroleum, more in-state jobs, and cleaner air.

Specifically, I recommend that DEQ allocate the maximum allowable amount (15%) of the funds for electric vehicle charging infrastructure and installations. And I encourage DEQ to prioritize electric vehicles and buses for replacement whenever possible with the other 85% of the settlement funds. Doing so will maximize the local economic impact and the reduction of air pollution.

I encourage you to not use the funding for natural gas, propane or diesel vehicles. Further dependence on fossil fuels means more pollution. Only a transition to electric vehicles and investment in EV infrastructure will put us on the road to a 100% clean transportation sector in North Carolina.

Sincerely,

Richard Martula
39 Kirby Road
Asheville, NC 28806
drdick61@gmail.com
(828) 505-2296

This message was sent by KnowWho, as a service provider only, on behalf of the individual noted in the sender information.

From: JUDY BREault (jblikes2go@aol.com) Sent You a Personal Message
To: [daq.NC_VWGrants](#)
Subject: [External] Use Volkswagen funds to electrify NC transportation
Date: Thursday, December 07, 2017 6:46:14 AM

CAUTION: External email. Do not click links or open attachments unless verified. Send all suspicious email as an attachment to report.spam@nc.gov.

Dear Division of Air Quality,

I am writing to urge DEQ to wisely invest the \$92 million in Volkswagen settlement funds in electric vehicles and infrastructure. Taking advantage of these funds to jumpstart the electrification of North Carolina's transportation sector will mean less money sent out of state for petroleum, more in-state jobs, and cleaner air.

Specifically, I recommend that DEQ allocate the maximum allowable amount (15%) of the funds for electric vehicle charging infrastructure and installations. And I encourage DEQ to prioritize electric vehicles and buses for replacement whenever possible with the other 85% of the settlement funds. Doing so will maximize the local economic impact and the reduction of air pollution.

I encourage you to not use the funding for natural gas, propane or diesel vehicles. Further dependence on fossil fuels means more pollution. Only a transition to electric vehicles and investment in EV infrastructure will put us on the road to a 100% clean transportation sector in North Carolina.

Sincerely,

JUDY BREault
4012 La Crema Drive
Charlotte, NC 28214
jblikes2go@aol.com
(704) 293-3193

This message was sent by KnowWho, as a service provider only, on behalf of the individual noted in the sender information.

From: Sue Perry (spinash@gmail.com) Sent You a Personal Message
To: [daq.NC_VWGrants](#)
Subject: [External] Use Volkswagen funds to electrify NC transportation
Date: Thursday, December 07, 2017 6:38:18 AM

CAUTION: External email. Do not click links or open attachments unless verified. Send all suspicious email as an attachment to report.spam@nc.gov.

Dear Division of Air Quality,

I am writing to urge DEQ to wisely invest the \$92 million in Volkswagen settlement funds in electric vehicles and infrastructure. Taking advantage of these funds to jumpstart the electrification of North Carolina's transportation sector will mean less money sent out of state for petroleum, more in-state jobs, and cleaner air.

Specifically, I recommend that DEQ allocate the maximum allowable amount (15%) of the funds for electric vehicle charging infrastructure and installations. And I encourage DEQ to prioritize electric vehicles and buses for replacement whenever possible with the other 85% of the settlement funds. Doing so will maximize the local economic impact and the reduction of air pollution.

I encourage you to not use the funding for natural gas, propane or diesel vehicles. Further dependence on fossil fuels means more pollution. Only a transition to electric vehicles and investment in EV infrastructure will put us on the road to a 100% clean transportation sector in North Carolina.

Sincerely,

Sue Perry
14 Quail Hollow
Asheville, NC 28804
spinash@gmail.com
(828) 575-9424

This message was sent by KnowWho, as a service provider only, on behalf of the individual noted in the sender information.

From: John Freeze (jfreeze@triad.rr.com) Sent You a Personal Message
To: [daq.NC_VWGrants](#)
Subject: [External] Use Volkswagen funds to electrify NC transportation
Date: Thursday, December 07, 2017 1:30:33 AM

CAUTION: External email. Do not click links or open attachments unless verified. Send all suspicious email as an attachment to report.spam@nc.gov.

Dear Division of Air Quality,

I am writing to urge DEQ to wisely invest the \$92 million in Volkswagen settlement funds in electric vehicles and infrastructure. Taking advantage of these funds to jumpstart the electrification of North Carolina's transportation sector will mean less money sent out of state for petroleum, more in-state jobs, and cleaner air.

Specifically, I recommend that DEQ allocate the maximum allowable amount (15%) of the funds for electric vehicle charging infrastructure and installations. And I encourage DEQ to prioritize electric vehicles and buses for replacement whenever possible with the other 85% of the settlement funds. Doing so will maximize the local economic impact and the reduction of air pollution.

I encourage you to not use the funding for natural gas, propane or diesel vehicles. Further dependence on fossil fuels means more pollution. Only a transition to electric vehicles and investment in EV infrastructure will put us on the road to a 100% clean transportation sector in North Carolina.

Sincerely,

John Freeze
648 Chaney Road
John, NC 27205
jfreeze@triad.rr.com
(336) 629-2208

This message was sent by KnowWho, as a service provider only, on behalf of the individual noted in the sender information.

From: Joseph Louis Mazzitelli (jlmazzitelli@gmail.com) Sent You a Personal Message
To: [daq.NC_VWGrants](#)
Subject: [External] Use Volkswagen funds to electrify NC transportation
Date: Thursday, December 07, 2017 12:06:05 AM

CAUTION: External email. Do not click links or open attachments unless verified. Send all suspicious email as an attachment to report.spam@nc.gov.

Dear Division of Air Quality,

I am writing to urge DEQ to wisely invest the \$92 million in Volkswagen settlement funds in electric vehicles and infrastructure. Taking advantage of these funds to jumpstart the electrification of North Carolina's transportation sector will mean less money sent out of state for petroleum, more in-state jobs, and cleaner air.

Specifically, I recommend that DEQ allocate the maximum allowable amount (15%) of the funds for electric vehicle charging infrastructure and installations. And I encourage DEQ to prioritize electric vehicles and buses for replacement whenever possible with the other 85% of the settlement funds. Doing so will maximize the local economic impact and the reduction of air pollution.

I encourage you to not use the funding for natural gas, propane or diesel vehicles. Further dependence on fossil fuels means more pollution. Only a transition to electric vehicles and investment in EV infrastructure will put us on the road to a 100% clean transportation sector in North Carolina.

Sincerely,

Joseph Louis Mazzitelli
2213 Highstone Rd
Cary, NC 27519
jlmazzitelli@gmail.com
(919) 319-0069

This message was sent by KnowWho, as a service provider only, on behalf of the individual noted in the sender information.

From: Yuliana Alcocer (yulianaalcocer@gmail.com) Sent You a Personal Message
To: [daq.NC_VWGrants](#)
Subject: [External] Use Volkswagen funds to electrify NC transportation
Date: Wednesday, December 06, 2017 11:43:00 PM

CAUTION: External email. Do not click links or open attachments unless verified. Send all suspicious email as an attachment to report.spam@nc.gov.

Dear Division of Air Quality,

I am writing to urge DEQ to wisely invest the \$92 million in Volkswagen settlement funds in electric vehicles and infrastructure. Taking advantage of these funds to jumpstart the electrification of North Carolina's transportation sector will mean less money sent out of state for petroleum, more in-state jobs, and cleaner air.

Specifically, I recommend that DEQ allocate the maximum allowable amount (15%) of the funds for electric vehicle charging infrastructure and installations. And I encourage DEQ to prioritize electric vehicles and buses for replacement whenever possible with the other 85% of the settlement funds. Doing so will maximize the local economic impact and the reduction of air pollution.

I encourage you to not use the funding for natural gas, propane or diesel vehicles. Further dependence on fossil fuels means more pollution. Only a transition to electric vehicles and investment in EV infrastructure will put us on the road to a 100% clean transportation sector in North Carolina.

Sincerely,

Yuliana Alcocer
1001 Burch Ave
Durham, NC 27701
yulianaalcocer@gmail.com
(919) 685-2348

This message was sent by KnowWho, as a service provider only, on behalf of the individual noted in the sender information.

From: ROBERT GROSS (gredgross@gmail.com) Sent You a Personal Message
To: [daq.NC_VWGrants](#)
Subject: [External] Use Volkswagen funds to electrify NC transportation
Date: Wednesday, December 06, 2017 11:00:05 PM

CAUTION: External email. Do not click links or open attachments unless verified. Send all suspicious email as an attachment to report.spam@nc.gov.

Dear Division of Air Quality,

I am writing to urge DEQ to wisely invest the \$92 million in Volkswagen settlement funds in electric vehicles and infrastructure. Taking advantage of these funds to jumpstart the electrification of North Carolina's transportation sector will mean less money sent out of state for petroleum, more in-state jobs, and cleaner air.

Specifically, I recommend that DEQ allocate the maximum allowable amount (15%) of the funds for electric vehicle charging infrastructure and installations. And I encourage DEQ to prioritize electric vehicles and buses for replacement whenever possible with the other 85% of the settlement funds. Doing so will maximize the local economic impact and the reduction of air pollution.

I encourage you to not use the funding for natural gas, propane or diesel vehicles. Further dependence on fossil fuels means more pollution. Only a transition to electric vehicles and investment in EV infrastructure will put us on the road to a 100% clean transportation sector in North Carolina.

Sincerely,

ROBERT GROSS
160 OHLE RD
BURNSVILLE, NC 28714
gredgross@gmail.com
(828) 678-5246

This message was sent by KnowWho, as a service provider only, on behalf of the individual noted in the sender information.

From: Bette-Burr Fenley (bbfenley3@gmail.com) Sent You a Personal Message
To: [daq.NC_VWGrants](#)
Subject: [External] Use Volkswagen funds to electrify NC transportation
Date: Wednesday, December 06, 2017 10:27:52 PM

CAUTION: External email. Do not click links or open attachments unless verified. Send all suspicious email as an attachment to report.spam@nc.gov.

Dear Division of Air Quality,

I am writing to urge DEQ to wisely invest the \$92 million in Volkswagen settlement funds in electric vehicles and infrastructure. Taking advantage of these funds to jumpstart the electrification of North Carolina's transportation sector will mean less money sent out of state for petroleum, more in-state jobs, and cleaner air.

Specifically, I recommend that DEQ allocate the maximum allowable amount (15%) of the funds for electric vehicle charging infrastructure and installations. And I encourage DEQ to prioritize electric vehicles and buses for replacement whenever possible with the other 85% of the settlement funds. Doing so will maximize the local economic impact and the reduction of air pollution.

I encourage you to not use the funding for natural gas, propane or diesel vehicles. Further dependence on fossil fuels means more pollution. Only a transition to electric vehicles and investment in EV infrastructure will put us on the road to a 100% clean transportation sector in North Carolina.

Sincerely,

Bette-Burr Fenley
211 Carolina Meadows Villa
Chapel Hill, NC 27517
bbfenley3@gmail.com
(919) 537-8071

This message was sent by KnowWho, as a service provider only, on behalf of the individual noted in the sender information.

From: Jessica Setzer (jssetzer11@me.com) Sent You a Personal Message
To: [daq.NC_VWGrants](#)
Subject: [External] Use Volkswagen funds to electrify NC transportation
Date: Wednesday, December 06, 2017 9:05:37 PM

CAUTION: External email. Do not click links or open attachments unless verified. Send all suspicious email as an attachment to report.spam@nc.gov.

Dear Division of Air Quality,

I am writing to urge DEQ to wisely invest the \$92 million in Volkswagen settlement funds in electric vehicles and infrastructure. Taking advantage of these funds to jumpstart the electrification of North Carolina's transportation sector will mean less money sent out of state for petroleum, more in-state jobs, and cleaner air.

Specifically, I recommend that DEQ allocate the maximum allowable amount (15%) of the funds for electric vehicle charging infrastructure and installations. And I encourage DEQ to prioritize electric vehicles and buses for replacement whenever possible with the other 85% of the settlement funds. Doing so will maximize the local economic impact and the reduction of air pollution.

I encourage you to not use the funding for natural gas, propane or diesel vehicles. Further dependence on fossil fuels means more pollution. Only a transition to electric vehicles and investment in EV infrastructure will put us on the road to a 100% clean transportation sector in North Carolina.

Sincerely,

Jessica Setzer
569 Sharon school rd
Statesville, NC 28625
jssetzer11@me.com
(828) 331-1630

This message was sent by KnowWho, as a service provider only, on behalf of the individual noted in the sender information.

From: Julie Finn (seedmoney@embarqmail.com) Sent You a Personal Message
To: [daq.NC_VWGrants](#)
Subject: [External] Use Volkswagen funds to electrify NC transportation
Date: Wednesday, December 06, 2017 8:56:32 PM

CAUTION: External email. Do not click links or open attachments unless verified. Send all suspicious email as an attachment to report.spam@nc.gov.

Dear Division of Air Quality,

I am writing to urge DEQ to wisely invest the \$92 million in Volkswagen settlement funds in electric vehicles and infrastructure. Taking advantage of these funds to jumpstart the electrification of North Carolina's transportation sector will mean less money sent out of state for petroleum, more in-state jobs, and cleaner air.

Specifically, I recommend that DEQ allocate the maximum allowable amount (15%) of the funds for electric vehicle charging infrastructure and installations. And I encourage DEQ to prioritize electric vehicles and buses for replacement whenever possible with the other 85% of the settlement funds. Doing so will maximize the local economic impact and the reduction of air pollution.

I encourage you to not use the funding for natural gas, propane or diesel vehicles. Further dependence on fossil fuels means more pollution. Only a transition to electric vehicles and investment in EV infrastructure will put us on the road to a 100% clean transportation sector in North Carolina.

Sincerely,

Julie Finn
101 Herman's Court
Moyock, NC 27958
seedmoney@embarqmail.com
(252) 435-6986

This message was sent by KnowWho, as a service provider only, on behalf of the individual noted in the sender information.

From: Debbie Burroughs (debbieburroughs@hotmail.com) Sent You a Personal Message
To: [daq.NC_VWGrants](#)
Subject: [External] Use Volkswagen funds to electrify NC transportation
Date: Wednesday, December 06, 2017 8:22:03 PM

CAUTION: External email. Do not click links or open attachments unless verified. Send all suspicious email as an attachment to report.spam@nc.gov.

Dear Division of Air Quality,

I am writing to urge DEQ to wisely invest the \$92 million in Volkswagen settlement funds in electric vehicles and infrastructure. Taking advantage of these funds to jumpstart the electrification of North Carolina's transportation sector will mean less money sent out of state for petroleum, more in-state jobs, and cleaner air.

Specifically, I recommend that DEQ allocate the maximum allowable amount (15%) of the funds for electric vehicle charging infrastructure and installations. And I encourage DEQ to prioritize electric vehicles and buses for replacement whenever possible with the other 85% of the settlement funds. Doing so will maximize the local economic impact and the reduction of air pollution.

I encourage you to not use the funding for natural gas, propane or diesel vehicles. Further dependence on fossil fuels means more pollution. Only a transition to electric vehicles and investment in EV infrastructure will put us on the road to a 100% clean transportation sector in North Carolina.

Sincerely,

Debbie Burroughs
111 Hobbs Acre Drive
Edenton, NC 27932
debbieburroughs@hotmail.com
(252) 482-7769

This message was sent by KnowWho, as a service provider only, on behalf of the individual noted in the sender information.

From: Nicole Dunn (nldunn9@gmail.com) Sent You a Personal Message
To: [daq.NC_VWGrants](#)
Subject: [External] Use Volkswagen funds to electrify NC transportation
Date: Wednesday, December 06, 2017 8:06:29 PM

CAUTION: External email. Do not click links or open attachments unless verified. Send all suspicious email as an attachment to report.spam@nc.gov.

Dear Division of Air Quality,

I am writing to urge DEQ to wisely invest the \$92 million in Volkswagen settlement funds in electric vehicles and infrastructure. Taking advantage of these funds to jumpstart the electrification of North Carolina's transportation sector will mean less money sent out of state for petroleum, more in-state jobs, and cleaner air.

Specifically, I recommend that DEQ allocate the maximum allowable amount (15%) of the funds for electric vehicle charging infrastructure and installations. And I encourage DEQ to prioritize electric vehicles and buses for replacement whenever possible with the other 85% of the settlement funds. Doing so will maximize the local economic impact and the reduction of air pollution.

I encourage you to not use the funding for natural gas, propane or diesel vehicles. Further dependence on fossil fuels means more pollution. Only a transition to electric vehicles and investment in EV infrastructure will put us on the road to a 100% clean transportation sector in North Carolina.

Sincerely,

Nicole Dunn
931 Millspring Dr
Durham, NC 27705
nldunn9@gmail.com
(845) 216-5814

This message was sent by KnowWho, as a service provider only, on behalf of the individual noted in the sender information.

From: Roxanne Chesnes (roxanne.bamboo@gmail.com) Sent You a Personal Message
To: [daq.NC_VWGrants](#)
Subject: [External] Use Volkswagen funds to electrify NC transportation
Date: Wednesday, December 06, 2017 7:48:26 PM

CAUTION: External email. Do not click links or open attachments unless verified. Send all suspicious email as an attachment to report.spam@nc.gov.

Dear Division of Air Quality,

I am writing to urge DEQ to wisely invest the \$92 million in Volkswagen settlement funds in electric vehicles and infrastructure. Taking advantage of these funds to jumpstart the electrification of North Carolina's transportation sector will mean less money sent out of state for petroleum, more in-state jobs, and cleaner air.

Specifically, I recommend that DEQ allocate the maximum allowable amount (15%) of the funds for electric vehicle charging infrastructure and installations. And I encourage DEQ to prioritize electric vehicles and buses for replacement whenever possible with the other 85% of the settlement funds. Doing so will maximize the local economic impact and the reduction of air pollution.

I encourage you to not use the funding for natural gas, propane or diesel vehicles. Further dependence on fossil fuels means more pollution. Only a transition to electric vehicles and investment in EV infrastructure will put us on the road to a 100% clean transportation sector in North Carolina.

Sincerely,

Roxanne Chesnes
132 A Half Moon Trail
Hendersonville, NC 28792
roxanne.bamboo@gmail.com
(828) 346-0066

This message was sent by KnowWho, as a service provider only, on behalf of the individual noted in the sender information.

From: Daniel Green (daniel.h.green@gmail.com) Sent You a Personal Message
To: [daq.NC_VWGrants](#)
Subject: [External] Use Volkswagen funds to electrify NC transportation
Date: Wednesday, December 06, 2017 7:44:07 PM

CAUTION: External email. Do not click links or open attachments unless verified. Send all suspicious email as an attachment to report.spam@nc.gov.

Dear Division of Air Quality,

I am writing to urge DEQ to wisely invest the \$92 million in Volkswagen settlement funds in electric vehicles and infrastructure. Taking advantage of these funds to jumpstart the electrification of North Carolina's transportation sector will mean less money sent out of state for petroleum, more in-state jobs, and cleaner air.

Specifically, I recommend that DEQ allocate the maximum allowable amount (15%) of the funds for electric vehicle charging infrastructure and installations. And I encourage DEQ to prioritize electric vehicles and buses for replacement whenever possible with the other 85% of the settlement funds. Doing so will maximize the local economic impact and the reduction of air pollution.

I encourage you to not use the funding for natural gas, propane or diesel vehicles. Further dependence on fossil fuels means more pollution. Only a transition to electric vehicles and investment in EV infrastructure will put us on the road to a 100% clean transportation sector in North Carolina.

Sincerely,

Daniel Green
4950 Currituck Drive
Charlotte, NC 28210
daniel.h.green@gmail.com
(704) 942-8269

This message was sent by KnowWho, as a service provider only, on behalf of the individual noted in the sender information.

From: Lara Kurth (larakurth@gmail.com) Sent You a Personal Message
To: [daq.NC_VWGrants](#)
Subject: [External] Use Volkswagen funds to electrify NC transportation
Date: Wednesday, December 06, 2017 7:37:56 PM

CAUTION: External email. Do not click links or open attachments unless verified. Send all suspicious email as an attachment to report.spam@nc.gov.

Dear Division of Air Quality,

I am writing to urge DEQ to wisely invest the \$92 million in Volkswagen settlement funds in electric vehicles and infrastructure. Taking advantage of these funds to jumpstart the electrification of North Carolina's transportation sector will mean less money sent out of state for petroleum, more in-state jobs, and cleaner air.

Specifically, I recommend that DEQ allocate the maximum allowable amount (15%) of the funds for electric vehicle charging infrastructure and installations. And I encourage DEQ to prioritize electric vehicles and buses for replacement whenever possible with the other 85% of the settlement funds. Doing so will maximize the local economic impact and the reduction of air pollution.

I encourage you to not use the funding for natural gas, propane or diesel vehicles. Further dependence on fossil fuels means more pollution. Only a transition to electric vehicles and investment in EV infrastructure will put us on the road to a 100% clean transportation sector in North Carolina.

Sincerely,

Lara Kurth
207 Hermitage Rd
Greensboro, NC 27403
larakurth@gmail.com
(724) 300-1066

This message was sent by KnowWho, as a service provider only, on behalf of the individual noted in the sender information.

From: Helen Woodward (nelliepg5@gmail.com) Sent You a Personal Message
To: [daq.NC_VWGrants](#)
Subject: [External] Use Volkswagen funds to electrify NC transportation
Date: Wednesday, December 06, 2017 6:29:39 PM

CAUTION: External email. Do not click links or open attachments unless verified. Send all suspicious email as an attachment to report.spam@nc.gov.

Dear Division of Air Quality,

I am writing to urge DEQ to wisely invest the \$92 million in Volkswagen settlement funds in electric vehicles and infrastructure. Taking advantage of these funds to jumpstart the electrification of North Carolina's transportation sector will mean less money sent out of state for petroleum, more in-state jobs, and cleaner air.

Specifically, I recommend that DEQ allocate the maximum allowable amount (15%) of the funds for electric vehicle charging infrastructure and installations. And I encourage DEQ to prioritize electric vehicles and buses for replacement whenever possible with the other 85% of the settlement funds. Doing so will maximize the local economic impact and the reduction of air pollution.

I encourage you to not use the funding for natural gas, propane or diesel vehicles. Further dependence on fossil fuels means more pollution. Only a transition to electric vehicles and investment in EV infrastructure will put us on the road to a 100% clean transportation sector in North Carolina.

Sincerely,

Helen Woodward
741 Spring Run Road
Winterville, NC 28590
nelliepg5@gmail.com
(252) 439-0119

This message was sent by KnowWho, as a service provider only, on behalf of the individual noted in the sender information.

From: Cheryl McGraw (chrrlgrrll@gmail.com) Sent You a Personal Message
To: [daq.NC_VWGrants](#)
Subject: [External] Use Volkswagen funds to electrify NC transportation
Date: Wednesday, December 06, 2017 5:20:22 PM

CAUTION: External email. Do not click links or open attachments unless verified. Send all suspicious email as an attachment to report.spam@nc.gov.

Dear Division of Air Quality,

I am writing to urge DEQ to wisely invest the \$92 million in Volkswagen settlement funds in electric vehicles and infrastructure. Taking advantage of these funds to jumpstart the electrification of North Carolina's transportation sector will mean less money sent out of state for petroleum, more in-state jobs, and cleaner air.

Specifically, I recommend that DEQ allocate the maximum allowable amount (15%) of the funds for electric vehicle charging infrastructure and installations. And I encourage DEQ to prioritize electric vehicles and buses for replacement whenever possible with the other 85% of the settlement funds. Doing so will maximize the local economic impact and the reduction of air pollution.

I encourage you to not use the funding for natural gas, propane or diesel vehicles. Further dependence on fossil fuels means more pollution. Only a transition to electric vehicles and investment in EV infrastructure will put us on the road to a 100% clean transportation sector in North Carolina.

Sincerely,

Cheryl McGraw
1004 Braxton Ct.
Raleigh, NC 27606
chrrlgrrll@gmail.com
(910) 470-0217

This message was sent by KnowWho, as a service provider only, on behalf of the individual noted in the sender information.

From: Joseph Wooten (burnswooten@charter.net) Sent You a Personal Message
To: [daq.NC_VWGrants](#)
Subject: [External] Use Volkswagen funds to electrify NC transportation
Date: Wednesday, December 06, 2017 4:49:14 PM

CAUTION: External email. Do not click links or open attachments unless verified. Send all suspicious email as an attachment to report.spam@nc.gov.

Dear Division of Air Quality,

I am writing to urge DEQ to wisely invest the \$92 million in Volkswagen settlement funds in electric vehicles and infrastructure. Taking advantage of these funds to jumpstart the electrification of North Carolina's transportation sector will mean less money sent out of state for petroleum, more in-state jobs, and cleaner air.

Specifically, I recommend that DEQ allocate the maximum allowable amount (15%) of the funds for electric vehicle charging infrastructure and installations. And I encourage DEQ to prioritize electric vehicles and buses for replacement whenever possible with the other 85% of the settlement funds. Doing so will maximize the local economic impact and the reduction of air pollution.

I encourage you to not use the funding for natural gas, propane or diesel vehicles. Further dependence on fossil fuels means more pollution. Only a transition to electric vehicles and investment in EV infrastructure will put us on the road to a 100% clean transportation sector in North Carolina.

Sincerely,

Joseph Wooten
1150 35th St. Pl. NE
Conover, NC 28613
burnswooten@charter.net
(828) 256-9793

This message was sent by KnowWho, as a service provider only, on behalf of the individual noted in the sender information.

From: Thomas Huzij (tomhuzij@icloud.com) Sent You a Personal Message
To: [daq.NC_VWGrants](#)
Subject: [External] Use Volkswagen funds to electrify NC transportation
Date: Wednesday, December 06, 2017 4:49:02 PM

CAUTION: External email. Do not click links or open attachments unless verified. Send all suspicious email as an attachment to report.spam@nc.gov.

Dear Division of Air Quality,

I am writing to urge DEQ to wisely invest the \$92 million in Volkswagen settlement funds in electric vehicles and infrastructure. Taking advantage of these funds to jumpstart the electrification of North Carolina's transportation sector will mean less money sent out of state for petroleum, more in-state jobs, and cleaner air.

Specifically, I recommend that DEQ allocate the maximum allowable amount (15%) of the funds for electric vehicle charging infrastructure and installations. And I encourage DEQ to prioritize electric vehicles and buses for replacement whenever possible with the other 85% of the settlement funds. Doing so will maximize the local economic impact and the reduction of air pollution.

I encourage you to not use the funding for natural gas, propane or diesel vehicles. Further dependence on fossil fuels means more pollution. Only a transition to electric vehicles and investment in EV infrastructure will put us on the road to a 100% clean transportation sector in North Carolina.

Sincerely,

Thomas Huzij
206 N Duke St Apt 115
Durham, NC 27701
tomhuzij@icloud.com
(347) 221-3770

This message was sent by KnowWho, as a service provider only, on behalf of the individual noted in the sender information.

From: F Myers (fmyers2007@twc.com) Sent You a Personal Message
To: daq.NC_VWGrants
Subject: [External] Use Volkswagen funds to electrify NC transportation
Date: Wednesday, December 06, 2017 4:18:53 PM

CAUTION: External email. Do not click links or open attachments unless verified. Send all suspicious email as an attachment to report.spam@nc.gov.

Dear Division of Air Quality,

I am writing to urge DEQ to wisely invest the \$92 million in Volkswagen settlement funds in electric vehicles and infrastructure. Taking advantage of these funds to jumpstart the electrification of North Carolina's transportation sector will mean less money sent out of state for petroleum, more in-state jobs, and cleaner air.

Specifically, I recommend that DEQ allocate the maximum allowable amount (15%) of the funds for electric vehicle charging infrastructure and installations. And I encourage DEQ to prioritize electric vehicles and buses for replacement whenever possible with the other 85% of the settlement funds. Doing so will maximize the local economic impact and the reduction of air pollution.

I encourage you to not use the funding for natural gas, propane or diesel vehicles. Further dependence on fossil fuels means more pollution. Only a transition to electric vehicles and investment in EV infrastructure will put us on the road to a 100% clean transportation sector in North Carolina.

Sincerely,

F Myers
5871 NC Highway 65
Reidsville, NC 27320
fmyers2007@twc.com
(336) 951-2003

This message was sent by KnowWho, as a service provider only, on behalf of the individual noted in the sender information.

From: Bill Groves (okiedokey7@sbcglobal.net) Sent You a Personal Message
To: daq.NC_VWGrants
Subject: [External] Use Volkswagen funds to electrify NC transportation
Date: Wednesday, December 06, 2017 3:52:15 PM

CAUTION: External email. Do not click links or open attachments unless verified. Send all suspicious email as an attachment to report.spam@nc.gov.

Dear Division of Air Quality,

I am writing to urge DEQ to wisely invest the \$92 million in Volkswagen settlement funds in electric vehicles and infrastructure. Taking advantage of these funds to jumpstart the electrification of North Carolina's transportation sector will mean less money sent out of state for petroleum, more in-state jobs, and cleaner air.

Specifically, I recommend that DEQ allocate the maximum allowable amount (15%) of the funds for electric vehicle charging infrastructure and installations. And I encourage DEQ to prioritize electric vehicles and buses for replacement whenever possible with the other 85% of the settlement funds. Doing so will maximize the local economic impact and the reduction of air pollution.

I encourage you to not use the funding for natural gas, propane or diesel vehicles. Further dependence on fossil fuels means more pollution. Only a transition to electric vehicles and investment in EV infrastructure will put us on the road to a 100% clean transportation sector in North Carolina.

Sincerely,

Bill Groves
738 Middle Skeenah Rd.
Franklin, NC 28734
okiedokey7@sbcglobal.net
(828) 371-6803

This message was sent by KnowWho, as a service provider only, on behalf of the individual noted in the sender information.

From: Elizabeth Miller (betsy1970@hotmail.com) Sent You a Personal Message
To: [daq.NC_VWGrants](#)
Subject: [External] Use Volkswagen funds to electrify NC transportation
Date: Wednesday, December 06, 2017 3:52:14 PM

CAUTION: External email. Do not click links or open attachments unless verified. Send all suspicious email as an attachment to report.spam@nc.gov.

Dear Division of Air Quality,

I am writing to urge DEQ to wisely invest the \$92 million in Volkswagen settlement funds in electric vehicles and infrastructure. Taking advantage of these funds to jumpstart the electrification of North Carolina's transportation sector will mean less money sent out of state for petroleum, more in-state jobs, and cleaner air.

Specifically, I recommend that DEQ allocate the maximum allowable amount (15%) of the funds for electric vehicle charging infrastructure and installations. And I encourage DEQ to prioritize electric vehicles and buses for replacement whenever possible with the other 85% of the settlement funds. Doing so will maximize the local economic impact and the reduction of air pollution.

I encourage you to not use the funding for natural gas, propane or diesel vehicles. Further dependence on fossil fuels means more pollution. Only a transition to electric vehicles and investment in EV infrastructure will put us on the road to a 100% clean transportation sector in North Carolina.

Sincerely,

Elizabeth Miller
610 Sasser Street
Raleigh, NC 27604
betsy1970@hotmail.com
(781) 366-1955

This message was sent by KnowWho, as a service provider only, on behalf of the individual noted in the sender information.

From: wendy upright (wendyupright@yahoo.com) Sent You a Personal Message
To: [daq.NC_VWGrants](#)
Subject: [External] Use Volkswagen funds to electrify NC transportation
Date: Wednesday, December 06, 2017 3:24:52 PM

CAUTION: External email. Do not click links or open attachments unless verified. Send all suspicious email as an attachment to report.spam@nc.gov.

Dear Division of Air Quality,

I am writing to urge DEQ to wisely invest the \$92 million in Volkswagen settlement funds in electric vehicles and infrastructure. Taking advantage of these funds to jumpstart the electrification of North Carolina's transportation sector will mean less money sent out of state for petroleum, more in-state jobs, and cleaner air.

Specifically, I recommend that DEQ allocate the maximum allowable amount (15%) of the funds for electric vehicle charging infrastructure and installations. And I encourage DEQ to prioritize electric vehicles and buses for replacement whenever possible with the other 85% of the settlement funds. Doing so will maximize the local economic impact and the reduction of air pollution.

I encourage you to not use the funding for natural gas, propane or diesel vehicles. Further dependence on fossil fuels means more pollution. Only a transition to electric vehicles and investment in EV infrastructure will put us on the road to a 100% clean transportation sector in North Carolina.

Sincerely,

wendy upright
183 old mill rd
penrose, NC 28766
wendyupright@yahoo.com
(828) 421-4613

This message was sent by KnowWho, as a service provider only, on behalf of the individual noted in the sender information.

From: Harriette Frank (lfrank1999@aol.com) Sent You a Personal Message
To: [daq.NC_VWGrants](#)
Subject: [External] Use Volkswagen funds to electrify NC transportation
Date: Wednesday, December 06, 2017 3:18:19 PM

CAUTION: External email. Do not click links or open attachments unless verified. Send all suspicious email as an attachment to report.spam@nc.gov.

Dear Division of Air Quality,

I am writing to urge DEQ to wisely invest the \$92 million in Volkswagen settlement funds in electric vehicles and infrastructure. Taking advantage of these funds to jumpstart the electrification of North Carolina's transportation sector will mean less money sent out of state for petroleum, more in-state jobs, and cleaner air.

Specifically, I recommend that DEQ allocate the maximum allowable amount (15%) of the funds for electric vehicle charging infrastructure and installations. And I encourage DEQ to prioritize electric vehicles and buses for replacement whenever possible with the other 85% of the settlement funds. Doing so will maximize the local economic impact and the reduction of air pollution.

I encourage you to not use the funding for natural gas, propane or diesel vehicles. Further dependence on fossil fuels means more pollution. Only a transition to electric vehicles and investment in EV infrastructure will put us on the road to a 100% clean transportation sector in North Carolina.

Sincerely,

Harriette Frank
3603 Westover Road
Durham, NC 27707
lfrank1999@aol.com
(919) 489-0555

This message was sent by KnowWho, as a service provider only, on behalf of the individual noted in the sender information.

From: Tyson Klose (tysonsk@gmail.com) Sent You a Personal Message
To: [daq.NC_VWGrants](#)
Subject: [External] Use Volkswagen funds to electrify NC transportation
Date: Wednesday, December 06, 2017 3:07:14 PM

CAUTION: External email. Do not click links or open attachments unless verified. Send all suspicious email as an attachment to report.spam@nc.gov.

Dear Division of Air Quality,

I am writing to urge DEQ to wisely invest the \$92 million in Volkswagen settlement funds in electric vehicles and infrastructure. Taking advantage of these funds to jumpstart the electrification of North Carolina's transportation sector will mean less money sent out of state for petroleum, more in-state jobs, and cleaner air.

Specifically, I recommend that DEQ allocate the maximum allowable amount (15%) of the funds for electric vehicle charging infrastructure and installations. And I encourage DEQ to prioritize electric vehicles and buses for replacement whenever possible with the other 85% of the settlement funds. Doing so will maximize the local economic impact and the reduction of air pollution.

I encourage you to not use the funding for natural gas, propane or diesel vehicles. Further dependence on fossil fuels means more pollution. Only a transition to electric vehicles and investment in EV infrastructure will put us on the road to a 100% clean transportation sector in North Carolina.

Sincerely,

Tyson Klose
2713 Weaver Hill Drive
Apex, NC 27502
tysonsk@gmail.com
(919) 744-7944

This message was sent by KnowWho, as a service provider only, on behalf of the individual noted in the sender information.

From: Sandra Mazo-Nix (sammazo@yahoo.com) Sent You a Personal Message
To: [daq.NC_VWGrants](#)
Subject: [External] Use Volkswagen funds to electrify NC transportation
Date: Wednesday, December 06, 2017 2:41:16 PM

CAUTION: External email. Do not click links or open attachments unless verified. Send all suspicious email as an attachment to report.spam@nc.gov.

Dear Division of Air Quality,

I am writing to urge DEQ to wisely invest the \$92 million in Volkswagen settlement funds in electric vehicles and infrastructure. Taking advantage of these funds to jumpstart the electrification of North Carolina's transportation sector will mean less money sent out of state for petroleum, more in-state jobs, and cleaner air.

Specifically, I recommend that DEQ allocate the maximum allowable amount (15%) of the funds for electric vehicle charging infrastructure and installations. And I encourage DEQ to prioritize electric vehicles and buses for replacement whenever possible with the other 85% of the settlement funds. Doing so will maximize the local economic impact and the reduction of air pollution.

I encourage you to not use the funding for natural gas, propane or diesel vehicles. Further dependence on fossil fuels means more pollution. Only a transition to electric vehicles and investment in EV infrastructure will put us on the road to a 100% clean transportation sector in North Carolina.

Sincerely,

Sandra Mazo-Nix
1015 Magnolia Leaf Ct
Apex, NC 27502
sammazo@yahoo.com
(703) 943-8245

This message was sent by KnowWho, as a service provider only, on behalf of the individual noted in the sender information.

From: Adam Mills (adamsethmills@yahoo.com) Sent You a Personal Message
To: [daq.NC_VWGrants](#)
Subject: [External] Use Volkswagen funds to electrify NC transportation
Date: Wednesday, December 06, 2017 2:40:10 PM

CAUTION: External email. Do not click links or open attachments unless verified. Send all suspicious email as an attachment to report.spam@nc.gov.

Dear Division of Air Quality,

I am writing to urge DEQ to wisely invest the \$92 million in Volkswagen settlement funds in electric vehicles and infrastructure. Taking advantage of these funds to jumpstart the electrification of North Carolina's transportation sector will mean less money sent out of state for petroleum, more in-state jobs, and cleaner air.

Specifically, I recommend that DEQ allocate the maximum allowable amount (15%) of the funds for electric vehicle charging infrastructure and installations. And I encourage DEQ to prioritize electric vehicles and buses for replacement whenever possible with the other 85% of the settlement funds. Doing so will maximize the local economic impact and the reduction of air pollution.

I encourage you to not use the funding for natural gas, propane or diesel vehicles. Further dependence on fossil fuels means more pollution. Only a transition to electric vehicles and investment in EV infrastructure will put us on the road to a 100% clean transportation sector in North Carolina.

Sincerely,

Adam Mills
408 Depot Street
Asheville, NC 28801
adamsethmills@yahoo.com
(828) 545-9070

This message was sent by KnowWho, as a service provider only, on behalf of the individual noted in the sender information.

From: Monica Sanchez (monica.northcarolina@yahoo.com) Sent You a Personal Message
To: [daq.NC_VWGrants](#)
Subject: [External] Use Volkswagen funds to electrify NC transportation
Date: Wednesday, December 06, 2017 2:22:10 PM

CAUTION: External email. Do not click links or open attachments unless verified. Send all suspicious email as an attachment to report.spam@nc.gov.

Dear Division of Air Quality,

I am writing to urge DEQ to wisely invest the \$92 million in Volkswagen settlement funds in electric vehicles and infrastructure. Taking advantage of these funds to jumpstart the electrification of North Carolina's transportation sector will mean less money sent out of state for petroleum, more in-state jobs, and cleaner air.

Specifically, I recommend that DEQ allocate the maximum allowable amount (15%) of the funds for electric vehicle charging infrastructure and installations. And I encourage DEQ to prioritize electric vehicles and buses for replacement whenever possible with the other 85% of the settlement funds. Doing so will maximize the local economic impact and the reduction of air pollution.

I encourage you to not use the funding for natural gas, propane or diesel vehicles. Further dependence on fossil fuels means more pollution. Only a transition to electric vehicles and investment in EV infrastructure will put us on the road to a 100% clean transportation sector in North Carolina.

Sincerely,

Monica Sanchez
64 Cedar Hills Cir.
Chapel Hill, NC 27514
monica.northcarolina@yahoo.com
(919) 968-6115

This message was sent by KnowWho, as a service provider only, on behalf of the individual noted in the sender information.

From: Jefferson Holt (jeffersonholt@me.com) Sent You a Personal Message
To: [daq.NC_VWGrants](#)
Subject: [External] Use Volkswagen funds to electrify NC transportation
Date: Wednesday, December 06, 2017 2:18:51 PM

CAUTION: External email. Do not click links or open attachments unless verified. Send all suspicious email as an attachment to report.spam@nc.gov.

Dear Division of Air Quality,

I am writing to urge DEQ to wisely invest the \$92 million in Volkswagen settlement funds in electric vehicles and infrastructure. Taking advantage of these funds to jumpstart the electrification of North Carolina's transportation sector will mean less money sent out of state for petroleum, more in-state jobs, and cleaner air.

Specifically, I recommend that DEQ allocate the maximum allowable amount (15%) of the funds for electric vehicle charging infrastructure and installations. And I encourage DEQ to prioritize electric vehicles and buses for replacement whenever possible with the other 85% of the settlement funds. Doing so will maximize the local economic impact and the reduction of air pollution.

I encourage you to not use the funding for natural gas, propane or diesel vehicles. Further dependence on fossil fuels means more pollution. Only a transition to electric vehicles and investment in EV infrastructure will put us on the road to a 100% clean transportation sector in North Carolina.

Sincerely,

Jefferson Holt
PO Box 1029
Carrboro, NC 27510
jeffersonholt@me.com
(919) 928-0054

This message was sent by KnowWho, as a service provider only, on behalf of the individual noted in the sender information.

From: Kicab Castaneda-Mendez (kicabcm@yahoo.com) Sent You a Personal Message
To: [daq.NC_VWGrants](#)
Subject: [External] Use Volkswagen funds to electrify NC transportation
Date: Wednesday, December 06, 2017 2:18:50 PM

CAUTION: External email. Do not click links or open attachments unless verified. Send all suspicious email as an attachment to report.spam@nc.gov.

Dear Division of Air Quality,

I am writing to urge DEQ to wisely invest the \$92 million in Volkswagen settlement funds in electric vehicles and infrastructure. Taking advantage of these funds to jumpstart the electrification of North Carolina's transportation sector will mean less money sent out of state for petroleum, more in-state jobs, and cleaner air.

Specifically, I recommend that DEQ allocate the maximum allowable amount (15%) of the funds for electric vehicle charging infrastructure and installations. And I encourage DEQ to prioritize electric vehicles and buses for replacement whenever possible with the other 85% of the settlement funds. Doing so will maximize the local economic impact and the reduction of air pollution.

I encourage you to not use the funding for natural gas, propane or diesel vehicles. Further dependence on fossil fuels means more pollution. Only a transition to electric vehicles and investment in EV infrastructure will put us on the road to a 100% clean transportation sector in North Carolina.

Sincerely,

Kicab Castaneda-Mendez
112 Rhododendron Court
Chapel Hill, NC 27517
kicabcm@yahoo.com
(919) 967-8782

This message was sent by KnowWho, as a service provider only, on behalf of the individual noted in the sender information.

From: James Zelbacher (jzelbacher@gmail.com) Sent You a Personal Message
To: [daq.NC_VWGrants](#)
Subject: [External] Use Volkswagen funds to electrify NC transportation
Date: Wednesday, December 06, 2017 2:13:07 PM

CAUTION: External email. Do not click links or open attachments unless verified. Send all suspicious email as an attachment to report.spam@nc.gov.

Dear Division of Air Quality,

I am writing to urge DEQ to wisely invest the \$92 million in Volkswagen settlement funds in electric vehicles and infrastructure. Taking advantage of these funds to jumpstart the electrification of North Carolina's transportation sector will mean less money sent out of state for petroleum, more in-state jobs, and cleaner air.

Specifically, I recommend that DEQ allocate the maximum allowable amount (15%) of the funds for electric vehicle charging infrastructure and installations. And I encourage DEQ to prioritize electric vehicles and buses for replacement whenever possible with the other 85% of the settlement funds. Doing so will maximize the local economic impact and the reduction of air pollution.

I encourage you to not use the funding for natural gas, propane or diesel vehicles. Further dependence on fossil fuels means more pollution. Only a transition to electric vehicles and investment in EV infrastructure will put us on the road to a 100% clean transportation sector in North Carolina.

Sincerely,

James Zelbacher
371 Jim Creek Rd
Burnsville, NC 28714
jzelbacher@gmail.com
(828) 284-3138

This message was sent by KnowWho, as a service provider only, on behalf of the individual noted in the sender information.

From: Jeffrey Petrella (jeffrey.petrella@duke.edu) Sent You a Personal Message
To: [daq.NC_VWGrants](#)
Subject: [External] Use Volkswagen funds to electrify NC transportation
Date: Wednesday, December 06, 2017 2:11:36 PM

CAUTION: External email. Do not click links or open attachments unless verified. Send all suspicious email as an attachment to report.spam@nc.gov.

Dear Division of Air Quality,

I am writing to urge DEQ to wisely invest the \$92 million in Volkswagen settlement funds in electric vehicles and infrastructure. Taking advantage of these funds to jumpstart the electrification of North Carolina's transportation sector will mean less money sent out of state for petroleum, more in-state jobs, and cleaner air.

Specifically, I recommend that DEQ allocate the maximum allowable amount (15%) of the funds for electric vehicle charging infrastructure and installations. And I encourage DEQ to prioritize electric vehicles and buses for replacement whenever possible with the other 85% of the settlement funds. Doing so will maximize the local economic impact and the reduction of air pollution.

I encourage you to not use the funding for natural gas, propane or diesel vehicles. Further dependence on fossil fuels means more pollution. Only a transition to electric vehicles and investment in EV infrastructure will put us on the road to a 100% clean transportation sector in North Carolina.

Sincerely,

Jeffrey Petrella
121 Lake Hogan Farm Rd
Chapel Hill, NC 27516
jeffrey.petrella@duke.edu
(919) 929-3980

This message was sent by KnowWho, as a service provider only, on behalf of the individual noted in the sender information.

From: lisa fisk (lisalfisk@gmail.com) Sent You a Personal Message
To: [daq.NC_VWGrants](#)
Subject: [External] Use Volkswagen funds to electrify NC transportation
Date: Wednesday, December 06, 2017 2:05:19 PM

CAUTION: External email. Do not click links or open attachments unless verified. Send all suspicious email as an attachment to report.spam@nc.gov.

Dear Division of Air Quality,

I am writing to urge DEQ to wisely invest the \$92 million in Volkswagen settlement funds in electric vehicles and infrastructure. Taking advantage of these funds to jumpstart the electrification of North Carolina's transportation sector will mean less money sent out of state for petroleum, more in-state jobs, and cleaner air.

Specifically, I recommend that DEQ allocate the maximum allowable amount (15%) of the funds for electric vehicle charging infrastructure and installations. And I encourage DEQ to prioritize electric vehicles and buses for replacement whenever possible with the other 85% of the settlement funds. Doing so will maximize the local economic impact and the reduction of air pollution.

I encourage you to not use the funding for natural gas, propane or diesel vehicles. Further dependence on fossil fuels means more pollution. Only a transition to electric vehicles and investment in EV infrastructure will put us on the road to a 100% clean transportation sector in North Carolina.

Sincerely,

lisa fisk
325 Tryon St.
Burlington, NC 27217
lisalfisk@gmail.com
(336) 350-8257

This message was sent by KnowWho, as a service provider only, on behalf of the individual noted in the sender information.

From: Randy Follas (mainman_95@hotmail.com) Sent You a Personal Message
To: [daq.NC_VWGrants](#)
Subject: [External] Use Volkswagen funds to electrify NC transportation
Date: Wednesday, December 06, 2017 1:44:09 PM

CAUTION: External email. Do not click links or open attachments unless verified. Send all suspicious email as an attachment to report.spam@nc.gov.

Dear Division of Air Quality,

I am writing to urge DEQ to wisely invest the \$92 million in Volkswagen settlement funds in electric vehicles and infrastructure. Taking advantage of these funds to jumpstart the electrification of North Carolina's transportation sector will mean less money sent out of state for petroleum, more in-state jobs, and cleaner air.

Specifically, I recommend that DEQ allocate the maximum allowable amount (15%) of the funds for electric vehicle charging infrastructure and installations. And I encourage DEQ to prioritize electric vehicles and buses for replacement whenever possible with the other 85% of the settlement funds. Doing so will maximize the local economic impact and the reduction of air pollution.

I encourage you to not use the funding for natural gas, propane or diesel vehicles. Further dependence on fossil fuels means more pollution. Only a transition to electric vehicles and investment in EV infrastructure will put us on the road to a 100% clean transportation sector in North Carolina.

Sincerely,

Randy Follas
201 Carabelle Circle
Salisbury, NC 28144
mainman_95@hotmail.com
(704) 647-0847

This message was sent by KnowWho, as a service provider only, on behalf of the individual noted in the sender information.

From: Tom Mathern (tmathern1@carolina.rr.com) Sent You a Personal Message
To: [daq.NC_VWGrants](#)
Subject: [External] Use Volkswagen funds to electrify NC transportation
Date: Wednesday, December 06, 2017 1:37:08 PM

CAUTION: External email. Do not click links or open attachments unless verified. Send all suspicious email as an attachment to report.spam@nc.gov.

Dear Division of Air Quality,

I am writing to urge DEQ to wisely invest the \$92 million in Volkswagen settlement funds in electric vehicles and infrastructure. Taking advantage of these funds to jumpstart the electrification of North Carolina's transportation sector will mean less money sent out of state for petroleum, more in-state jobs, and cleaner air.

Specifically, I recommend that DEQ allocate the maximum allowable amount (15%) of the funds for electric vehicle charging infrastructure and installations. And I encourage DEQ to prioritize electric vehicles and buses for replacement whenever possible with the other 85% of the settlement funds. Doing so will maximize the local economic impact and the reduction of air pollution.

I encourage you to not use the funding for natural gas, propane or diesel vehicles. Further dependence on fossil fuels means more pollution. Only a transition to electric vehicles and investment in EV infrastructure will put us on the road to a 100% clean transportation sector in North Carolina.

Sincerely,

Tom Mathern
11617 Chestnut Hill DR
Matthews, NC 28105
tmathern1@carolina.rr.com
(704) 248-0017

This message was sent by KnowWho, as a service provider only, on behalf of the individual noted in the sender information.

From: David Fairall (dafair@aol.com) Sent You a Personal Message
To: [daq.NC_VWGrants](#)
Subject: [External] Use Volkswagen funds to electrify NC transportation
Date: Wednesday, December 06, 2017 1:19:52 PM

CAUTION: External email. Do not click links or open attachments unless verified. Send all suspicious email as an attachment to report.spam@nc.gov.

Dear Division of Air Quality,

I am writing to urge DEQ to wisely invest the \$92 million in Volkswagen settlement funds in electric vehicles and infrastructure. Taking advantage of these funds to jumpstart the electrification of North Carolina's transportation sector will mean less money sent out of state for petroleum, more in-state jobs, and cleaner air.

Specifically, I recommend that DEQ allocate the maximum allowable amount (15%) of the funds for electric vehicle charging infrastructure and installations. And I encourage DEQ to prioritize electric vehicles and buses for replacement whenever possible with the other 85% of the settlement funds. Doing so will maximize the local economic impact and the reduction of air pollution.

I encourage you to not use the funding for natural gas, propane or diesel vehicles. Further dependence on fossil fuels means more pollution. Only a transition to electric vehicles and investment in EV infrastructure will put us on the road to a 100% clean transportation sector in North Carolina.

Sincerely,

David Fairall
4828 Selwyn Drive
Winston-Salem, NC 27104
dafair@aol.com
(336) 247-6888

This message was sent by KnowWho, as a service provider only, on behalf of the individual noted in the sender information.

From: Philip Singer (phil_singer@unc.edu) Sent You a Personal Message
To: [daq.NC_VWGrants](#)
Subject: [External] Use Volkswagen funds to electrify NC transportation
Date: Wednesday, December 06, 2017 1:18:48 PM

CAUTION: External email. Do not click links or open attachments unless verified. Send all suspicious email as an attachment to report.spam@nc.gov.

Dear Division of Air Quality,

I am writing to urge DEQ to wisely invest the \$92 million in Volkswagen settlement funds in electric vehicles and infrastructure. Taking advantage of these funds to jumpstart the electrification of North Carolina's transportation sector will mean less money sent out of state for petroleum, more in-state jobs, and cleaner air.

Specifically, I recommend that DEQ allocate the maximum allowable amount (15%) of the funds for electric vehicle charging infrastructure and installations. And I encourage DEQ to prioritize electric vehicles and buses for replacement whenever possible with the other 85% of the settlement funds. Doing so will maximize the local economic impact and the reduction of air pollution.

I encourage you to not use the funding for natural gas, propane or diesel vehicles. Further dependence on fossil fuels means more pollution. Only a transition to electric vehicles and investment in EV infrastructure will put us on the road to a 100% clean transportation sector in North Carolina.

Sincerely,

Philip Singer
213 Arcadia Lane
Chapel Hill, NC 27514
phil_singer@unc.edu
(919) 608-5509

This message was sent by KnowWho, as a service provider only, on behalf of the individual noted in the sender information.

From: Sarah Haley (sarahjhaley@gmail.com) Sent You a Personal Message
To: [daq.NC_VWGrants](#)
Subject: [External] Use Volkswagen funds to electrify NC transportation
Date: Wednesday, December 06, 2017 1:06:32 PM

CAUTION: External email. Do not click links or open attachments unless verified. Send all suspicious email as an attachment to report.spam@nc.gov.

Dear Division of Air Quality,

I am writing to urge DEQ to wisely invest the \$92 million in Volkswagen settlement funds in electric vehicles and infrastructure. Taking advantage of these funds to jumpstart the electrification of North Carolina's transportation sector will mean less money sent out of state for petroleum, more in-state jobs, and cleaner air.

Specifically, I recommend that DEQ allocate the maximum allowable amount (15%) of the funds for electric vehicle charging infrastructure and installations. And I encourage DEQ to prioritize electric vehicles and buses for replacement whenever possible with the other 85% of the settlement funds. Doing so will maximize the local economic impact and the reduction of air pollution.

I encourage you to not use the funding for natural gas, propane or diesel vehicles. Further dependence on fossil fuels means more pollution. Only a transition to electric vehicles and investment in EV infrastructure will put us on the road to a 100% clean transportation sector in North Carolina.

Sincerely,

Sarah Haley
612 Clement Avenue Apt 2
Charlotte, NC 28204
sarahjhaley@gmail.com
(605) 212-7361

This message was sent by KnowWho, as a service provider only, on behalf of the individual noted in the sender information.

From: Margaret Lillard (margaret.lillard@sierraclub.org) Sent You a Personal Message
To: [daq.NC_VWGrants](#)
Subject: [External] Use Volkswagen funds to electrify NC transportation
Date: Wednesday, December 06, 2017 12:54:43 PM

CAUTION: External email. Do not click links or open attachments unless verified. Send all suspicious email as an attachment to report.spam@nc.gov.

Dear Division of Air Quality,

I am writing to urge DEQ to wisely invest the \$92 million in Volkswagen settlement funds in electric vehicles and infrastructure. Taking advantage of these funds to jumpstart the electrification of North Carolina's transportation sector will mean less money sent out of state for petroleum, more in-state jobs, and cleaner air.

Specifically, I recommend that DEQ allocate the maximum allowable amount (15%) of the funds for electric vehicle charging infrastructure and installations. And I encourage DEQ to prioritize electric vehicles and buses for replacement whenever possible with the other 85% of the settlement funds. Doing so will maximize the local economic impact and the reduction of air pollution.

I encourage you to not use the funding for natural gas, propane or diesel vehicles. Further dependence on fossil fuels means more pollution. Only a transition to electric vehicles and investment in EV infrastructure will put us on the road to a 100% clean transportation sector in North Carolina.

Sincerely,

Margaret Lillard
5800 Oatstone Pl
Raleigh, NC 27606
margaret.lillard@sierraclub.org
(919) 332-8979

This message was sent by KnowWho, as a service provider only, on behalf of the individual noted in the sender information.

From: Brandon Becker (brandonvx@gmail.com) Sent You a Personal Message
To: [daq.NC_VWGrants](#)
Subject: [External] Use Volkswagen funds to electrify NC transportation
Date: Wednesday, December 06, 2017 12:54:22 PM

CAUTION: External email. Do not click links or open attachments unless verified. Send all suspicious email as an attachment to report.spam@nc.gov.

Dear Division of Air Quality,

I am writing to urge DEQ to wisely invest the \$92 million in Volkswagen settlement funds in electric vehicles and infrastructure. Taking advantage of these funds to jumpstart the electrification of North Carolina's transportation sector will mean less money sent out of state for petroleum, more in-state jobs, and cleaner air.

Specifically, I recommend that DEQ allocate the maximum allowable amount (15%) of the funds for electric vehicle charging infrastructure and installations. And I encourage DEQ to prioritize electric vehicles and buses for replacement whenever possible with the other 85% of the settlement funds. Doing so will maximize the local economic impact and the reduction of air pollution.

I encourage you to not use the funding for natural gas, propane or diesel vehicles. Further dependence on fossil fuels means more pollution. Only a transition to electric vehicles and investment in EV infrastructure will put us on the road to a 100% clean transportation sector in North Carolina.

Sincerely,

Brandon Becker
401 Applecross Drive
Cary, NC 27511
brandonvx@gmail.com
(919) 454-4397

This message was sent by KnowWho, as a service provider only, on behalf of the individual noted in the sender information.

From: Dean Herington (dheringt@gmail.com) Sent You a Personal Message
To: [daq.NC_VWGrants](#)
Subject: [External] Use Volkswagen funds to electrify NC transportation
Date: Wednesday, December 06, 2017 12:53:03 PM

CAUTION: External email. Do not click links or open attachments unless verified. Send all suspicious email as an attachment to report.spam@nc.gov.

Dear Division of Air Quality,

I am writing to urge DEQ to wisely invest the \$92 million in Volkswagen settlement funds in electric vehicles and infrastructure. Taking advantage of these funds to jumpstart the electrification of North Carolina's transportation sector will mean less money sent out of state for petroleum, more in-state jobs, and cleaner air.

Specifically, I recommend that DEQ allocate the maximum allowable amount (15%) of the funds for electric vehicle charging infrastructure and installations. And I encourage DEQ to prioritize electric vehicles and buses for replacement whenever possible with the other 85% of the settlement funds. Doing so will maximize the local economic impact and the reduction of air pollution.

I encourage you to not use the funding for natural gas, propane or diesel vehicles. Further dependence on fossil fuels means more pollution. Only a transition to electric vehicles and investment in EV infrastructure will put us on the road to a 100% clean transportation sector in North Carolina.

Sincerely,

Dean Herington
128 W. Queen St.
Dean, NC 27278
dheringt@gmail.com
(919) 644-0126

This message was sent by KnowWho, as a service provider only, on behalf of the individual noted in the sender information.

From: Jaedra Luke (jaedraluke@gmail.com) Sent You a Personal Message
To: [daq.NC_VWGrants](#)
Subject: [External] Use Volkswagen funds to electrify NC transportation
Date: Wednesday, December 06, 2017 12:43:00 PM

CAUTION: External email. Do not click links or open attachments unless verified. Send all suspicious email as an attachment to report.spam@nc.gov.

Dear Division of Air Quality,

I am writing to urge DEQ to wisely invest the \$92 million in Volkswagen settlement funds in electric vehicles and infrastructure. Taking advantage of these funds to jumpstart the electrification of North Carolina's transportation sector will mean less money sent out of state for petroleum, more in-state jobs, and cleaner air.

Specifically, I recommend that DEQ allocate the maximum allowable amount (15%) of the funds for electric vehicle charging infrastructure and installations. And I encourage DEQ to prioritize electric vehicles and buses for replacement whenever possible with the other 85% of the settlement funds. Doing so will maximize the local economic impact and the reduction of air pollution.

I encourage you to not use the funding for natural gas, propane or diesel vehicles. Further dependence on fossil fuels means more pollution. Only a transition to electric vehicles and investment in EV infrastructure will put us on the road to a 100% clean transportation sector in North Carolina.

Sincerely,

Jaedra Luke
9395 Greenville Hwy Brevard NC 28712 United States
Brevard, NC 28712
jaedraluke@gmail.com
(310) 422-7109

This message was sent by KnowWho, as a service provider only, on behalf of the individual noted in the sender information.

From: Harvey Richmond
To: [daq.NC_VWGrants](#)
Subject: [External] RE: Questions on NC VW RFI
Date: Wednesday, December 06, 2017 12:40:57 PM

CAUTION: External email. Do not click links or open attachments unless verified. Send all suspicious email as an attachment to report.spam@nc.gov.

I am a retired senior environmental analyst who worked on national air quality standards with the U.S. EPA for over 31 years. I'm also a volunteer leader with the Capital Group of the Sierra Club. The comments I am providing are my own and do not necessarily represent the opinions of either the EPA or the Sierra Club.

I strongly urge the NC DEQ to invest the \$92 million in VW settlement funds in electric vehicles and infrastructure. The DEQ should allocate the maximum allowable amount (15%) of the funds for light duty electric vehicle charging infrastructure. The remaining funds should be used to support purchase of school and other electric buses. Focusing the use of the VW settlement funds in these two areas will result in reduced conventional air pollutants (e.g., particulates matter, nitrogen oxides, and VOC's), and will reduce emissions of methane and carbon that contribute to climate change.

I strongly encourage DEQ not to use any of these funds for natural gas, propane or diesel vehicles. Any increase in natural gas fueled vehicles contributes to additional methane emissions which pose a serious risk to our climate. We need to be moving away from fossil fuels, not adding to our climate problems.

The VW settlement provides a unique opportunity to move our state and our country forward towards a cleaner, and safer for our climate, transportation system.

Harvey M. Richmond , MSPH, MPA
106 Hebride Court
Cary, NC 27513
harvey4climateaction@gmail.com
(919) 801-2472 (mobile)

From: Irving Edelstein (iedelstein@carolina.rr.com) Sent You a Personal Message
To: [daq.NC_VWGrants](#)
Subject: [External] Use Volkswagen funds to electrify NC transportation
Date: Wednesday, December 06, 2017 12:33:53 PM

CAUTION: External email. Do not click links or open attachments unless verified. Send all suspicious email as an attachment to report.spam@nc.gov.

Dear Division of Air Quality,

I am writing to urge DEQ to wisely invest the \$92 million in Volkswagen settlement funds in electric vehicles and infrastructure. Taking advantage of these funds to jumpstart the electrification of North Carolina's transportation sector will mean less money sent out of state for petroleum, more in-state jobs, and cleaner air.

Specifically, I recommend that DEQ allocate the maximum allowable amount (15%) of the funds for electric vehicle charging infrastructure and installations. And I encourage DEQ to prioritize electric vehicles and buses for replacement whenever possible with the other 85% of the settlement funds. Doing so will maximize the local economic impact and the reduction of air pollution.

I encourage you to not use the funding for natural gas, propane or diesel vehicles. Further dependence on fossil fuels means more pollution. Only a transition to electric vehicles and investment in EV infrastructure will put us on the road to a 100% clean transportation sector in North Carolina.

Sincerely,

Irving Edelstein
9303 Lochmeade Ln
Matthews, NC 28105
iedelstein@carolina.rr.com
(704) 366-5133

This message was sent by KnowWho, as a service provider only, on behalf of the individual noted in the sender information.

From: jerry hamilton (jerrykhamilton@gmail.com) Sent You a Personal Message
To: [daq.NC_VWGrants](#)
Subject: [External] Use Volkswagen funds to electrify NC transportation
Date: Wednesday, December 06, 2017 12:28:29 PM

CAUTION: External email. Do not click links or open attachments unless verified. Send all suspicious email as an attachment to report.spam@nc.gov.

Dear Division of Air Quality,

I am writing to urge DEQ to wisely invest the \$92 million in Volkswagen settlement funds in electric vehicles and infrastructure. Taking advantage of these funds to jumpstart the electrification of North Carolina's transportation sector will mean less money sent out of state for petroleum, more in-state jobs, and cleaner air.

Specifically, I recommend that DEQ allocate the maximum allowable amount (15%) of the funds for electric vehicle charging infrastructure and installations. And I encourage DEQ to prioritize electric vehicles and buses for replacement whenever possible with the other 85% of the settlement funds. Doing so will maximize the local economic impact and the reduction of air pollution.

I encourage you to not use the funding for natural gas, propane or diesel vehicles. Further dependence on fossil fuels means more pollution. Only a transition to electric vehicles and investment in EV infrastructure will put us on the road to a 100% clean transportation sector in North Carolina.

Sincerely,

jerry hamilton
5305 Boshier Lake Dr
McLeansville, NC 27301
jerrykhamilton@gmail.com
(336) 697-9769

This message was sent by KnowWho, as a service provider only, on behalf of the individual noted in the sender information.

From: Charles Cloak (chcloak2@yahoo.com) Sent You a Personal Message
To: [daq.NC_VWGrants](#)
Subject: [External] Use Volkswagen funds to electrify NC transportation
Date: Wednesday, December 06, 2017 12:25:21 PM

CAUTION: External email. Do not click links or open attachments unless verified. Send all suspicious email as an attachment to report.spam@nc.gov.

Dear Division of Air Quality,

I am writing to urge DEQ to wisely invest the \$92 million in Volkswagen settlement funds in electric vehicles and infrastructure. Taking advantage of these funds to jumpstart the electrification of North Carolina's transportation sector will mean less money sent out of state for petroleum, more in-state jobs, and cleaner air.

Specifically, I recommend that DEQ allocate the maximum allowable amount (15%) of the funds for electric vehicle charging infrastructure and installations. And I encourage DEQ to prioritize electric vehicles and buses for replacement whenever possible with the other 85% of the settlement funds. Doing so will maximize the local economic impact and the reduction of air pollution.

I encourage you to not use the funding for natural gas, propane or diesel vehicles. Further dependence on fossil fuels means more pollution. Only a transition to electric vehicles and investment in EV infrastructure will put us on the road to a 100% clean transportation sector in North Carolina.

Sincerely,

Charles Cloak
28 Olde Eastwood Village Blvd
Asheville, NC 28803
chcloak2@yahoo.com
(828) 273-8475

This message was sent by KnowWho, as a service provider only, on behalf of the individual noted in the sender information.

From: Kenneth Rose (kenrosesc@gmail.com) Sent You a Personal Message
To: [daq.NC_VWGrants](#)
Subject: [External] Use Volkswagen funds to electrify NC transportation
Date: Wednesday, December 06, 2017 12:14:44 PM

CAUTION: External email. Do not click links or open attachments unless verified. Send all suspicious email as an attachment to report.spam@nc.gov.

Dear Division of Air Quality,

I am writing to urge DEQ to wisely invest the \$92 million in Volkswagen settlement funds in electric vehicles and infrastructure. Taking advantage of these funds to jumpstart the electrification of North Carolina's transportation sector will mean less money sent out of state for petroleum, more in-state jobs, and cleaner air.

Specifically, I recommend that DEQ allocate the maximum allowable amount (15%) of the funds for electric vehicle charging infrastructure and installations. And I encourage DEQ to prioritize electric vehicles and buses for replacement whenever possible with the other 85% of the settlement funds. Doing so will maximize the local economic impact and the reduction of air pollution.

I encourage you to not use the funding for natural gas, propane or diesel vehicles. Further dependence on fossil fuels means more pollution. Only a transition to electric vehicles and investment in EV infrastructure will put us on the road to a 100% clean transportation sector in North Carolina.

Sincerely,

Kenneth Rose
809 Carolina Ave.
Durham, NC 27705
kenrosesc@gmail.com
(919) 886-0350

This message was sent by KnowWho, as a service provider only, on behalf of the individual noted in the sender information.

From: John Bastian (jrbastian88@gmail.com) Sent You a Personal Message
To: [daq.NC_VWGrants](#)
Subject: [External] Use Volkswagen funds to electrify NC transportation
Date: Wednesday, December 06, 2017 12:12:04 PM

CAUTION: External email. Do not click links or open attachments unless verified. Send all suspicious email as an attachment to report.spam@nc.gov.

Dear Division of Air Quality,

I am writing to urge DEQ to wisely invest the \$92 million in Volkswagen settlement funds in electric vehicles and infrastructure. Taking advantage of these funds to jumpstart the electrification of North Carolina's transportation sector will mean less money sent out of state for petroleum, more in-state jobs, and cleaner air.

Specifically, I recommend that DEQ allocate the maximum allowable amount (15%) of the funds for electric vehicle charging infrastructure and installations. And I encourage DEQ to prioritize electric vehicles and buses for replacement whenever possible with the other 85% of the settlement funds. Doing so will maximize the local economic impact and the reduction of air pollution.

I encourage you to not use the funding for natural gas, propane or diesel vehicles. Further dependence on fossil fuels means more pollution. Only a transition to electric vehicles and investment in EV infrastructure will put us on the road to a 100% clean transportation sector in North Carolina.

Sincerely,

John Bastian
28 Arbor Hill Place
McLeansville, NC 27301
jrbastian88@gmail.com
(757) 630-0664

This message was sent by KnowWho, as a service provider only, on behalf of the individual noted in the sender information.

From: Amy Herman (keepcalm1951@gmail.com) Sent You a Personal Message
To: [daq.NC_VWGrants](#)
Subject: [External] Use Volkswagen funds to electrify NC transportation
Date: Wednesday, December 06, 2017 12:00:42 PM

CAUTION: External email. Do not click links or open attachments unless verified. Send all suspicious email as an attachment to report.spam@nc.gov.

Dear Division of Air Quality,

I am writing to urge DEQ to wisely invest the \$92 million in Volkswagen settlement funds in electric vehicles and infrastructure. Taking advantage of these funds to jumpstart the electrification of North Carolina's transportation sector will mean less money sent out of state for petroleum, more in-state jobs, and cleaner air.

Specifically, I recommend that DEQ allocate the maximum allowable amount (15%) of the funds for electric vehicle charging infrastructure and installations. And I encourage DEQ to prioritize electric vehicles and buses for replacement whenever possible with the other 85% of the settlement funds. Doing so will maximize the local economic impact and the reduction of air pollution.

I encourage you to not use the funding for natural gas, propane or diesel vehicles. Further dependence on fossil fuels means more pollution. Only a transition to electric vehicles and investment in EV infrastructure will put us on the road to a 100% clean transportation sector in North Carolina.

Sincerely,

Amy Herman
102 Oak Dale Lane
Morganton, NC 28655
keepcalm1951@gmail.com
(828) 334-3016

This message was sent by KnowWho, as a service provider only, on behalf of the individual noted in the sender information.

From: Nancy Rominger (nancy.rominger@gmail.com) Sent You a Personal Message
To: [daq.NC_VWGrants](#)
Subject: [External] Use Volkswagen funds to electrify NC transportation
Date: Wednesday, December 06, 2017 12:00:32 PM

CAUTION: External email. Do not click links or open attachments unless verified. Send all suspicious email as an attachment to report.spam@nc.gov.

Dear Division of Air Quality,

I am writing to urge DEQ to wisely invest the \$92 million in Volkswagen settlement funds in electric vehicles and infrastructure. Taking advantage of these funds to jumpstart the electrification of North Carolina's transportation sector will mean less money sent out of state for petroleum, more in-state jobs, and cleaner air.

Specifically, I recommend that DEQ allocate the maximum allowable amount (15%) of the funds for electric vehicle charging infrastructure and installations. And I encourage DEQ to prioritize electric vehicles and buses for replacement whenever possible with the other 85% of the settlement funds. Doing so will maximize the local economic impact and the reduction of air pollution.

I encourage you to not use the funding for natural gas, propane or diesel vehicles. Further dependence on fossil fuels means more pollution. Only a transition to electric vehicles and investment in EV infrastructure will put us on the road to a 100% clean transportation sector in North Carolina.

Sincerely,

Nancy Rominger
140 S. Oakhurst Dr.
Salisbury, NC 28147
nancy.rominger@gmail.com
(704) 640-9082

This message was sent by KnowWho, as a service provider only, on behalf of the individual noted in the sender information.

From: Patricia Ruge (pmrsnr@aol.com) Sent You a Personal Message
To: [daq.NC_VWGrants](#)
Subject: [External] Use Volkswagen funds to electrify NC transportation
Date: Wednesday, December 06, 2017 11:53:29 AM

CAUTION: External email. Do not click links or open attachments unless verified. Send all suspicious email as an attachment to report.spam@nc.gov.

Dear Division of Air Quality,

I am writing to urge DEQ to wisely invest the \$92 million in Volkswagen settlement funds in electric vehicles and infrastructure. Taking advantage of these funds to jumpstart the electrification of North Carolina's transportation sector will mean less money sent out of state for petroleum, more in-state jobs, and cleaner air.

Specifically, I recommend that DEQ allocate the maximum allowable amount (15%) of the funds for electric vehicle charging infrastructure and installations. And I encourage DEQ to prioritize electric vehicles and buses for replacement whenever possible with the other 85% of the settlement funds. Doing so will maximize the local economic impact and the reduction of air pollution.

I encourage you to not use the funding for natural gas, propane or diesel vehicles. Further dependence on fossil fuels means more pollution. Only a transition to electric vehicles and investment in EV infrastructure will put us on the road to a 100% clean transportation sector in North Carolina.

Sincerely,

Patricia Ruge
2829 Springfield Dr
Wilmington, NC 28405
pmrsnr@aol.com
(201) 467-5545

This message was sent by KnowWho, as a service provider only, on behalf of the individual noted in the sender information.

From: helen Johnson (mtnhelenrose@yahoo.com) Sent You a Personal Message
To: [daq.NC_VWGrants](#)
Subject: [External] Use Volkswagen funds to electrify NC transportation
Date: Wednesday, December 06, 2017 11:46:07 AM

CAUTION: External email. Do not click links or open attachments unless verified. Send all suspicious email as an attachment to report.spam@nc.gov.

Dear Division of Air Quality,

I am writing to urge DEQ to wisely invest the \$92 million in Volkswagen settlement funds in electric vehicles and infrastructure. Taking advantage of these funds to jumpstart the electrification of North Carolina's transportation sector will mean less money sent out of state for petroleum, more in-state jobs, and cleaner air.

Specifically, I recommend that DEQ allocate the maximum allowable amount (15%) of the funds for electric vehicle charging infrastructure and installations. And I encourage DEQ to prioritize electric vehicles and buses for replacement whenever possible with the other 85% of the settlement funds. Doing so will maximize the local economic impact and the reduction of air pollution.

I encourage you to not use the funding for natural gas, propane or diesel vehicles. Further dependence on fossil fuels means more pollution. Only a transition to electric vehicles and investment in EV infrastructure will put us on the road to a 100% clean transportation sector in North Carolina.

Sincerely,

helen Johnson
75 Mountain View Rd
Black Mountain, NC 28711
mtnhelenrose@yahoo.com
(828) 669-2562

This message was sent by KnowWho, as a service provider only, on behalf of the individual noted in the sender information.

From: Michael Marshall (mmmarsha@uncg.edu) Sent You a Personal Message
To: [daq.NC_VWGrants](#)
Subject: [External] Use Volkswagen funds to electrify NC transportation
Date: Wednesday, December 06, 2017 11:20:46 AM

CAUTION: External email. Do not click links or open attachments unless verified. Send all suspicious email as an attachment to report.spam@nc.gov.

Dear Division of Air Quality,

I am writing to urge DEQ to wisely invest the \$92 million in Volkswagen settlement funds in electric vehicles and infrastructure. Taking advantage of these funds to jumpstart the electrification of North Carolina's transportation sector will mean less money sent out of state for petroleum, more in-state jobs, and cleaner air.

Specifically, I recommend that DEQ allocate the maximum allowable amount (15%) of the funds for electric vehicle charging infrastructure and installations. And I encourage DEQ to prioritize electric vehicles and buses for replacement whenever possible with the other 85% of the settlement funds. Doing so will maximize the local economic impact and the reduction of air pollution.

I encourage you to not use the funding for natural gas, propane or diesel vehicles. Further dependence on fossil fuels means more pollution. Only a transition to electric vehicles and investment in EV infrastructure will put us on the road to a 100% clean transportation sector in North Carolina.

Sincerely,

Michael Marshall
605 Hannah McKenzie Dr
Greensboro, NC 27455
mmmarsha@uncg.edu
(336) 545-0171

This message was sent by KnowWho, as a service provider only, on behalf of the individual noted in the sender information.

From: Yeazel, Seth Matthew
To: [daq.NC_VWGrants](#)
Subject: [External] VW Emissions Settlement comment
Date: Wednesday, December 06, 2017 11:17:12 AM

CAUTION: External email. Do not click links or open attachments unless verified. Send all suspicious email as an attachment to report.spam@nc.gov.

One of the most important aspects of this program is that North Carolina electrify, rather than refurbish and replace old diesel engines with new diesel or natural gas engines.

This is not only important in that we move away from fossil fuels, but this is also incumbent upon the state and that North Carolina will receive more funding.

Putting money toward vehicle charging stations is smart, and if the state does this coordinating this spending with the other pool of money meant exclusively for charging stations will be key.

Additionally, I believe it is wise to invest in electrification of buses. Buses transport many people (esp kids for school) and are more highly concentrated in poor, minority, and EJ communities. Buses will also be an easier target because data will be more readily available than for other technologies, and this will make modeling emissions reductions easier compared to alternative investments.

One thing for DEQ to consider is where progress toward electrification is inevitable. With this in mind, focusing on electrifying port technologies, for example, may be wise. Vehicle electrification seems all but guaranteed, but this is not the case with Port Drayage machinery, for example.

Finally, it would be wise for the state to make great use of leveraging DERA matching funds. I strongly urge DEQ to engage heavily in this program.

Best,
Seth Yeazel

112C Purefoy Rd.
Chapel Hill, NC
27514
386-846-3219

From: Camelia Stewart (astewart5@ec.rr.com) Sent You a Personal Message
To: [daq.NC_VWGrants](#)
Subject: [External] Use Volkswagen funds to electrify NC transportation
Date: Wednesday, December 06, 2017 11:14:09 AM

CAUTION: External email. Do not click links or open attachments unless verified. Send all suspicious email as an attachment to report.spam@nc.gov.

Dear Division of Air Quality,

I am writing to urge DEQ to wisely invest the \$92 million in Volkswagen settlement funds in electric vehicles and infrastructure. Taking advantage of these funds to jumpstart the electrification of North Carolina's transportation sector will mean less money sent out of state for petroleum, more in-state jobs, and cleaner air.

Specifically, I recommend that DEQ allocate the maximum allowable amount (15%) of the funds for electric vehicle charging infrastructure and installations. And I encourage DEQ to prioritize electric vehicles and buses for replacement whenever possible with the other 85% of the settlement funds. Doing so will maximize the local economic impact and the reduction of air pollution.

I encourage you to not use the funding for natural gas, propane or diesel vehicles. Further dependence on fossil fuels means more pollution. Only a transition to electric vehicles and investment in EV infrastructure will put us on the road to a 100% clean transportation sector in North Carolina.

Sincerely,

Camelia Stewart
322 Loblolly St.
Emerald Isle, NC 28594
astewart5@ec.rr.com
(252) 354-5984

This message was sent by KnowWho, as a service provider only, on behalf of the individual noted in the sender information.

From: Ellen Osborne (peaceeao7@aol.com) Sent You a Personal Message
To: [daq.NC_VWGrants](#)
Subject: [External] Use Volkswagen funds to electrify NC transportation
Date: Wednesday, December 06, 2017 11:13:55 AM

CAUTION: External email. Do not click links or open attachments unless verified. Send all suspicious email as an attachment to report.spam@nc.gov.

Dear Division of Air Quality,

I am writing to urge DEQ to wisely invest the \$92 million in Volkswagen settlement funds in electric vehicles and infrastructure. Taking advantage of these funds to jumpstart the electrification of North Carolina's transportation sector will mean less money sent out of state for petroleum, more in-state jobs, and cleaner air.

Specifically, I recommend that DEQ allocate the maximum allowable amount (15%) of the funds for electric vehicle charging infrastructure and installations. And I encourage DEQ to prioritize electric vehicles and buses for replacement whenever possible with the other 85% of the settlement funds. Doing so will maximize the local economic impact and the reduction of air pollution.

I encourage you to not use the funding for natural gas, propane or diesel vehicles. Further dependence on fossil fuels means more pollution. Only a transition to electric vehicles and investment in EV infrastructure will put us on the road to a 100% clean transportation sector in North Carolina.

Sincerely,

Ellen Osborne
6731, Hunt RD
Pleasant Garden, NC 27313
peaceeao7@aol.com
(336) 317-9231

This message was sent by KnowWho, as a service provider only, on behalf of the individual noted in the sender information.

From: David Williams (dmw1nc@aol.com) Sent You a Personal Message
To: [daq.NC_VWGrants](#)
Subject: [External] Use Volkswagen funds to electrify NC transportation
Date: Wednesday, December 06, 2017 11:04:30 AM

CAUTION: External email. Do not click links or open attachments unless verified. Send all suspicious email as an attachment to report.spam@nc.gov.

Dear Division of Air Quality,

I am writing to urge DEQ to wisely invest the \$92 million in Volkswagen settlement funds in electric vehicles and infrastructure. Taking advantage of these funds to jumpstart the electrification of North Carolina's transportation sector will mean less money sent out of state for petroleum, more in-state jobs, and cleaner air.

Specifically, I recommend that DEQ allocate the maximum allowable amount (15%) of the funds for electric vehicle charging infrastructure and installations. And I encourage DEQ to prioritize electric vehicles and buses for replacement whenever possible with the other 85% of the settlement funds. Doing so will maximize the local economic impact and the reduction of air pollution.

I encourage you to not use the funding for natural gas, propane or diesel vehicles. Further dependence on fossil fuels means more pollution. Only a transition to electric vehicles and investment in EV infrastructure will put us on the road to a 100% clean transportation sector in North Carolina.

Sincerely,

David Williams
12 Willoughby Run Drive
Asheville, NC 28803
dmw1nc@aol.com
(828) 687-2835

This message was sent by KnowWho, as a service provider only, on behalf of the individual noted in the sender information.

From: Doris Hinson (dorismhinson@gmail.com) Sent You a Personal Message
To: [daq.NC_VWGrants](#)
Subject: [External] Use Volkswagen funds to electrify NC transportation
Date: Wednesday, December 06, 2017 10:56:52 AM

CAUTION: External email. Do not click links or open attachments unless verified. Send all suspicious email as an attachment to report.spam@nc.gov.

Dear Division of Air Quality,

I am writing to urge DEQ to wisely invest the \$92 million in Volkswagen settlement funds in electric vehicles and infrastructure. Taking advantage of these funds to jumpstart the electrification of North Carolina's transportation sector will mean less money sent out of state for petroleum, more in-state jobs, and cleaner air.

Specifically, I recommend that DEQ allocate the maximum allowable amount (15%) of the funds for electric vehicle charging infrastructure and installations. And I encourage DEQ to prioritize electric vehicles and buses for replacement whenever possible with the other 85% of the settlement funds. Doing so will maximize the local economic impact and the reduction of air pollution.

I encourage you to not use the funding for natural gas, propane or diesel vehicles. Further dependence on fossil fuels means more pollution. Only a transition to electric vehicles and investment in EV infrastructure will put us on the road to a 100% clean transportation sector in North Carolina.

Sincerely,

Doris Hinson
9 Fircrest Court
Durham, NC 27703
dorismhinson@gmail.com
(919) 596-7687

This message was sent by KnowWho, as a service provider only, on behalf of the individual noted in the sender information.

From: helga barden (helgameister@charter.net) Sent You a Personal Message
To: [daq.NC_VWGrants](#)
Subject: [External] Use Volkswagen funds to electrify NC transportation
Date: Wednesday, December 06, 2017 10:53:27 AM

CAUTION: External email. Do not click links or open attachments unless verified. Send all suspicious email as an attachment to report.spam@nc.gov.

Dear Division of Air Quality,

I am writing to urge DEQ to wisely invest the \$92 million in Volkswagen settlement funds in electric vehicles and infrastructure. Taking advantage of these funds to jumpstart the electrification of North Carolina's transportation sector will mean less money sent out of state for petroleum, more in-state jobs, and cleaner air.

Specifically, I recommend that DEQ allocate the maximum allowable amount (15%) of the funds for electric vehicle charging infrastructure and installations. And I encourage DEQ to prioritize electric vehicles and buses for replacement whenever possible with the other 85% of the settlement funds. Doing so will maximize the local economic impact and the reduction of air pollution.

I encourage you to not use the funding for natural gas, propane or diesel vehicles. Further dependence on fossil fuels means more pollution. Only a transition to electric vehicles and investment in EV infrastructure will put us on the road to a 100% clean transportation sector in North Carolina.

Sincerely,

helga barden
114 Old Toll Rd
Asheville, NC 28804
helgameister@charter.net
(828) 230-1807

This message was sent by KnowWho, as a service provider only, on behalf of the individual noted in the sender information.

From: Valarie Snell (valariesnell@yahoo.com) Sent You a Personal Message
To: [daq.NC_VWGrants](#)
Subject: [External] Use Volkswagen funds to electrify NC transportation
Date: Wednesday, December 06, 2017 10:53:25 AM

CAUTION: External email. Do not click links or open attachments unless verified. Send all suspicious email as an attachment to report.spam@nc.gov.

Dear Division of Air Quality,

I am writing to urge DEQ to wisely invest the \$92 million in Volkswagen settlement funds in electric vehicles and infrastructure. Taking advantage of these funds to jumpstart the electrification of North Carolina's transportation sector will mean less money sent out of state for petroleum, more in-state jobs, and cleaner air.

Specifically, I recommend that DEQ allocate the maximum allowable amount (15%) of the funds for electric vehicle charging infrastructure and installations. And I encourage DEQ to prioritize electric vehicles and buses for replacement whenever possible with the other 85% of the settlement funds. Doing so will maximize the local economic impact and the reduction of air pollution.

I encourage you to not use the funding for natural gas, propane or diesel vehicles. Further dependence on fossil fuels means more pollution. Only a transition to electric vehicles and investment in EV infrastructure will put us on the road to a 100% clean transportation sector in North Carolina.

Sincerely,

Valarie Snell
1217 Cliffwood Drive
Greensboro, NC 27406
valariesnell@yahoo.com
(336) 404-1506

This message was sent by KnowWho, as a service provider only, on behalf of the individual noted in the sender information.

From: Martin Benavides (martin.benavides1@gmail.com) Sent You a Personal Message
To: [daq.NC_VWGrants](#)
Subject: [External] Use Volkswagen funds to electrify NC transportation
Date: Wednesday, December 06, 2017 10:50:54 AM

CAUTION: External email. Do not click links or open attachments unless verified. Send all suspicious email as an attachment to report.spam@nc.gov.

Dear Division of Air Quality,

I am writing to urge DEQ to wisely invest the \$92 million in Volkswagen settlement funds in electric vehicles and infrastructure. Taking advantage of these funds to jumpstart the electrification of North Carolina's transportation sector will mean less money sent out of state for petroleum, more in-state jobs, and cleaner air.

Specifically, I recommend that DEQ allocate the maximum allowable amount (15%) of the funds for electric vehicle charging infrastructure and installations. And I encourage DEQ to prioritize electric vehicles and buses for replacement whenever possible with the other 85% of the settlement funds. Doing so will maximize the local economic impact and the reduction of air pollution.

I encourage you to not use the funding for natural gas, propane or diesel vehicles. Further dependence on fossil fuels means more pollution. Only a transition to electric vehicles and investment in EV infrastructure will put us on the road to a 100% clean transportation sector in North Carolina.

Sincerely,

Martin Benavides
2906 Evans Street
Morehead City, NC 28557
martin.benavides1@gmail.com
(252) 269-3445

This message was sent by KnowWho, as a service provider only, on behalf of the individual noted in the sender information.

From: Nancy Kondracki (nancykondracki13@gmail.com) Sent You a Personal Message
To: [daq.NC_VWGrants](#)
Subject: [External] Use Volkswagen funds to electrify NC transportation
Date: Wednesday, December 06, 2017 10:50:52 AM

CAUTION: External email. Do not click links or open attachments unless verified. Send all suspicious email as an attachment to report.spam@nc.gov.

Dear Division of Air Quality,

I am writing to urge DEQ to wisely invest the \$92 million in Volkswagen settlement funds in electric vehicles and infrastructure. Taking advantage of these funds to jumpstart the electrification of North Carolina's transportation sector will mean less money sent out of state for petroleum, more in-state jobs, and cleaner air.

Specifically, I recommend that DEQ allocate the maximum allowable amount (15%) of the funds for electric vehicle charging infrastructure and installations. And I encourage DEQ to prioritize electric vehicles and buses for replacement whenever possible with the other 85% of the settlement funds. Doing so will maximize the local economic impact and the reduction of air pollution.

I encourage you to not use the funding for natural gas, propane or diesel vehicles. Further dependence on fossil fuels means more pollution. Only a transition to electric vehicles and investment in EV infrastructure will put us on the road to a 100% clean transportation sector in North Carolina.

Sincerely,

Nancy Kondracki
5211 Flintrock Court
Greensboro, NC 27455
nancykondracki13@gmail.com
(336) 282-9558

This message was sent by KnowWho, as a service provider only, on behalf of the individual noted in the sender information.

From: Mac Hulslander (mac.hulslander@gmail.com) Sent You a Personal Message
To: [daq.NC_VWGrants](#)
Subject: [External] Use Volkswagen funds to electrify NC transportation
Date: Wednesday, December 06, 2017 10:44:43 AM

CAUTION: External email. Do not click links or open attachments unless verified. Send all suspicious email as an attachment to report.spam@nc.gov.

Dear Division of Air Quality,

I am writing to urge DEQ to wisely invest the \$92 million in Volkswagen settlement funds in electric vehicles and infrastructure. Taking advantage of these funds to jumpstart the electrification of North Carolina's transportation sector will mean less money sent out of state for petroleum, more in-state jobs, and cleaner air.

Specifically, I recommend that DEQ allocate the maximum allowable amount (15%) of the funds for electric vehicle charging infrastructure and installations. And I encourage DEQ to prioritize electric vehicles and buses for replacement whenever possible with the other 85% of the settlement funds. Doing so will maximize the local economic impact and the reduction of air pollution.

I encourage you to not use the funding for natural gas, propane or diesel vehicles. Further dependence on fossil fuels means more pollution. Only a transition to electric vehicles and investment in EV infrastructure will put us on the road to a 100% clean transportation sector in North Carolina.

Sincerely,

Mac Hulslander
2830 Barmettler St.
Raleigh, NC 27607
mac.hulslander@gmail.com
(919) 833-7203

This message was sent by KnowWho, as a service provider only, on behalf of the individual noted in the sender information.

From: Thomas Games (tmgames@yahoo.com) Sent You a Personal Message
To: [daq.NC_VWGrants](#)
Subject: [External] Use Volkswagen funds to electrify NC transportation
Date: Wednesday, December 06, 2017 10:34:19 AM

CAUTION: External email. Do not click links or open attachments unless verified. Send all suspicious email as an attachment to report.spam@nc.gov.

Dear Division of Air Quality,

I am writing to urge DEQ to wisely invest the \$92 million in Volkswagen settlement funds in electric vehicles and infrastructure. Taking advantage of these funds to jumpstart the electrification of North Carolina's transportation sector will mean less money sent out of state for petroleum, more in-state jobs, and cleaner air.

Specifically, I recommend that DEQ allocate the maximum allowable amount (15%) of the funds for electric vehicle charging infrastructure and installations. And I encourage DEQ to prioritize electric vehicles and buses for replacement whenever possible with the other 85% of the settlement funds. Doing so will maximize the local economic impact and the reduction of air pollution.

I encourage you to not use the funding for natural gas, propane or diesel vehicles. Further dependence on fossil fuels means more pollution. Only a transition to electric vehicles and investment in EV infrastructure will put us on the road to a 100% clean transportation sector in North Carolina.

Sincerely,

Thomas Games
12209 Kyle Abbey Ln.
Raleigh, NC 27613
tmgames@yahoo.com
(919) 917-7547

This message was sent by KnowWho, as a service provider only, on behalf of the individual noted in the sender information.

From: Ryan Segall (rsegall.f15@warren-wilson.edu) Sent You a Personal Message
To: [daq.NC_VWGrants](#)
Subject: [External] Use Volkswagen funds to electrify NC transportation
Date: Wednesday, December 06, 2017 10:31:58 AM

CAUTION: External email. Do not click links or open attachments unless verified. Send all suspicious email as an attachment to report.spam@nc.gov.

Dear Division of Air Quality,

I am writing to urge DEQ to wisely invest the \$92 million in Volkswagen settlement funds in electric vehicles and infrastructure. Taking advantage of these funds to jumpstart the electrification of North Carolina's transportation sector will mean less money sent out of state for petroleum, more in-state jobs, and cleaner air.

Specifically, I recommend that DEQ allocate the maximum allowable amount (15%) of the funds for electric vehicle charging infrastructure and installations. And I encourage DEQ to prioritize electric vehicles and buses for replacement whenever possible with the other 85% of the settlement funds. Doing so will maximize the local economic impact and the reduction of air pollution.

I encourage you to not use the funding for natural gas, propane or diesel vehicles. Further dependence on fossil fuels means more pollution. Only a transition to electric vehicles and investment in EV infrastructure will put us on the road to a 100% clean transportation sector in North Carolina.

Sincerely,

Ryan Segall
107 Pink Fox Cove Rd
Weaverville, NC 28787
rsegall.f15@warren-wilson.edu
(828) 645-8395

This message was sent by KnowWho, as a service provider only, on behalf of the individual noted in the sender information.

From: Ada Khoury (inthemoment007@yahoo.com) Sent You a Personal Message
To: [daq.NC_VWGrants](#)
Subject: [External] Use Volkswagen funds to electrify NC transportation
Date: Wednesday, December 06, 2017 10:24:06 AM

CAUTION: External email. Do not click links or open attachments unless verified. Send all suspicious email as an attachment to report.spam@nc.gov.

Dear Division of Air Quality,

I am writing to urge DEQ to wisely invest the \$92 million in Volkswagen settlement funds in electric vehicles and infrastructure. Taking advantage of these funds to jumpstart the electrification of North Carolina's transportation sector will mean less money sent out of state for petroleum, more in-state jobs, and cleaner air.

Specifically, I recommend that DEQ allocate the maximum allowable amount (15%) of the funds for electric vehicle charging infrastructure and installations. And I encourage DEQ to prioritize electric vehicles and buses for replacement whenever possible with the other 85% of the settlement funds. Doing so will maximize the local economic impact and the reduction of air pollution.

I encourage you to not use the funding for natural gas, propane or diesel vehicles. Further dependence on fossil fuels means more pollution. Only a transition to electric vehicles and investment in EV infrastructure will put us on the road to a 100% clean transportation sector in North Carolina.

Sincerely,

Ada Khoury
P o box 646
Weaverville, NC 28787
inthemoment007@yahoo.com
(828) 713-8051

This message was sent by KnowWho, as a service provider only, on behalf of the individual noted in the sender information.

From: Barry Auman (bauman@atmc.net) Sent You a Personal Message
To: [daq.NC_VWGrants](#)
Subject: [External] Use Volkswagen funds to electrify NC transportation
Date: Wednesday, December 06, 2017 10:15:45 AM

CAUTION: External email. Do not click links or open attachments unless verified. Send all suspicious email as an attachment to report.spam@nc.gov.

Dear Division of Air Quality,

I am writing to urge DEQ to wisely invest the \$92 million in Volkswagen settlement funds in electric vehicles and infrastructure. Taking advantage of these funds to jumpstart the electrification of North Carolina's transportation sector will mean less money sent out of state for petroleum, more in-state jobs, and cleaner air.

Specifically, I recommend that DEQ allocate the maximum allowable amount (15%) of the funds for electric vehicle charging infrastructure and installations. And I encourage DEQ to prioritize electric vehicles and buses for replacement whenever possible with the other 85% of the settlement funds. Doing so will maximize the local economic impact and the reduction of air pollution.

I encourage you to not use the funding for natural gas, propane or diesel vehicles. Further dependence on fossil fuels means more pollution. Only a transition to electric vehicles and investment in EV infrastructure will put us on the road to a 100% clean transportation sector in North Carolina.

Sincerely,

Barry Auman
543 Sunset Lakes Blvd. Sw
Sunset Beach, NC 28468
bauman@atmc.net
(910) 579-1485

This message was sent by KnowWho, as a service provider only, on behalf of the individual noted in the sender information.

From: Pat Scudiere (pbscudiere@gmail.com) Sent You a Personal Message
To: [daq.NC_VWGrants](#)
Subject: [External] Use Volkswagen funds to electrify NC transportation
Date: Wednesday, December 06, 2017 10:15:10 AM

CAUTION: External email. Do not click links or open attachments unless verified. Send all suspicious email as an attachment to report.spam@nc.gov.

Dear Division of Air Quality,

I am writing to urge DEQ to wisely invest the \$92 million in Volkswagen settlement funds in electric vehicles and infrastructure. Taking advantage of these funds to jumpstart the electrification of North Carolina's transportation sector will mean less money sent out of state for petroleum, more in-state jobs, and cleaner air.

Specifically, I recommend that DEQ allocate the maximum allowable amount (15%) of the funds for electric vehicle charging infrastructure and installations. And I encourage DEQ to prioritize electric vehicles and buses for replacement whenever possible with the other 85% of the settlement funds. Doing so will maximize the local economic impact and the reduction of air pollution.

I encourage you to not use the funding for natural gas, propane or diesel vehicles. Further dependence on fossil fuels means more pollution. Only a transition to electric vehicles and investment in EV infrastructure will put us on the road to a 100% clean transportation sector in North Carolina.

Sincerely,

Pat Scudiere
106 Berkshire St
Greensboro, NC 27403
pbscudiere@gmail.com
(336) 870-3065

This message was sent by KnowWho, as a service provider only, on behalf of the individual noted in the sender information.

From: Julia Martinelli (jdmartinelli222@yahoo.com) Sent You a Personal Message
To: [daq.NC_VWGrants](#)
Subject: [External] Use Volkswagen funds to electrify NC transportation
Date: Wednesday, December 06, 2017 10:13:03 AM

CAUTION: External email. Do not click links or open attachments unless verified. Send all suspicious email as an attachment to report.spam@nc.gov.

Dear Division of Air Quality,

I am writing to urge DEQ to wisely invest the \$92 million in Volkswagen settlement funds in electric vehicles and infrastructure. Taking advantage of these funds to jumpstart the electrification of North Carolina's transportation sector will mean less money sent out of state for petroleum, more in-state jobs, and cleaner air.

Specifically, I recommend that DEQ allocate the maximum allowable amount (15%) of the funds for electric vehicle charging infrastructure and installations. And I encourage DEQ to prioritize electric vehicles and buses for replacement whenever possible with the other 85% of the settlement funds. Doing so will maximize the local economic impact and the reduction of air pollution.

I encourage you to not use the funding for natural gas, propane or diesel vehicles. Further dependence on fossil fuels means more pollution. Only a transition to electric vehicles and investment in EV infrastructure will put us on the road to a 100% clean transportation sector in North Carolina.

Sincerely,

Julia Martinelli
8918 Landing Drive, SW
Sunset Beach, NC 28468
jdmartinelli222@yahoo.com
(910) 579-4445

This message was sent by KnowWho, as a service provider only, on behalf of the individual noted in the sender information.

From: Arthur Firth (afirth@carolina.rr.com) Sent You a Personal Message
To: [daq.NC_VWGrants](#)
Subject: [External] Use Volkswagen funds to electrify NC transportation
Date: Wednesday, December 06, 2017 10:07:49 AM

CAUTION: External email. Do not click links or open attachments unless verified. Send all suspicious email as an attachment to report.spam@nc.gov.

Dear Division of Air Quality,

I am writing to urge DEQ to wisely invest the \$92 million in Volkswagen settlement funds in electric vehicles and infrastructure. Taking advantage of these funds to jumpstart the electrification of North Carolina's transportation sector will mean less money sent out of state for petroleum, more in-state jobs, and cleaner air.

Specifically, I recommend that DEQ allocate the maximum allowable amount (15%) of the funds for electric vehicle charging infrastructure and installations. And I encourage DEQ to prioritize electric vehicles and buses for replacement whenever possible with the other 85% of the settlement funds. Doing so will maximize the local economic impact and the reduction of air pollution.

I encourage you to not use the funding for natural gas, propane or diesel vehicles. Further dependence on fossil fuels means more pollution. Only a transition to electric vehicles and investment in EV infrastructure will put us on the road to a 100% clean transportation sector in North Carolina.

Sincerely,

Arthur Firth
1011 Emerald Bay Drive
Salisbury, NC 28146
afirth@carolina.rr.com
(704) 633-3069

This message was sent by KnowWho, as a service provider only, on behalf of the individual noted in the sender information.

From: Robert Carson (rcarson31@ms.com) Sent You a Personal Message
To: [daq.NC_VWGrants](#)
Subject: [External] Use Volkswagen funds to electrify NC transportation
Date: Wednesday, December 06, 2017 10:07:35 AM

CAUTION: External email. Do not click links or open attachments unless verified. Send all suspicious email as an attachment to report.spam@nc.gov.

Dear Division of Air Quality,

I am writing to urge DEQ to wisely invest the \$92 million in Volkswagen settlement funds in electric vehicles and infrastructure. Taking advantage of these funds to jumpstart the electrification of North Carolina's transportation sector will mean less money sent out of state for petroleum, more in-state jobs, and cleaner air.

Specifically, I recommend that DEQ allocate the maximum allowable amount (15%) of the funds for electric vehicle charging infrastructure and installations. And I encourage DEQ to prioritize electric vehicles and buses for replacement whenever possible with the other 85% of the settlement funds. Doing so will maximize the local economic impact and the reduction of air pollution.

I encourage you to not use the funding for natural gas, propane or diesel vehicles. Further dependence on fossil fuels means more pollution. Only a transition to electric vehicles and investment in EV infrastructure will put us on the road to a 100% clean transportation sector in North Carolina.

Sincerely,

Robert Carson
361 Dillingham Circle
Asheville, NC 28805
rcarson31@ms.com
(828) 424-7075

This message was sent by KnowWho, as a service provider only, on behalf of the individual noted in the sender information.

From: David Galloway (dhgallow@gmail.com) Sent You a Personal Message
To: [daq.NC_VWGrants](#)
Subject: [External] Use Volkswagen funds to electrify NC transportation
Date: Wednesday, December 06, 2017 10:04:29 AM

CAUTION: External email. Do not click links or open attachments unless verified. Send all suspicious email as an attachment to report.spam@nc.gov.

Dear Division of Air Quality,

I am writing to urge DEQ to wisely invest the \$92 million in Volkswagen settlement funds in electric vehicles and infrastructure. Taking advantage of these funds to jumpstart the electrification of North Carolina's transportation sector will mean less money sent out of state for petroleum, more in-state jobs, and cleaner air.

Specifically, I recommend that DEQ allocate the maximum allowable amount (15%) of the funds for electric vehicle charging infrastructure and installations. And I encourage DEQ to prioritize electric vehicles and buses for replacement whenever possible with the other 85% of the settlement funds. Doing so will maximize the local economic impact and the reduction of air pollution.

I encourage you to not use the funding for natural gas, propane or diesel vehicles. Further dependence on fossil fuels means more pollution. Only a transition to electric vehicles and investment in EV infrastructure will put us on the road to a 100% clean transportation sector in North Carolina.

Sincerely,

David Galloway
3705 Highgate Dr, Apt G
Durham, NC 27713
dhgallow@gmail.com
(919) 495-1107

This message was sent by KnowWho, as a service provider only, on behalf of the individual noted in the sender information.

From: Anne Jarema (anne_jarema@verizon.net) Sent You a Personal Message
To: [daq.NC_VWGrants](#)
Subject: [External] Use Volkswagen funds to electrify NC transportation
Date: Wednesday, December 06, 2017 10:03:49 AM

CAUTION: External email. Do not click links or open attachments unless verified. Send all suspicious email as an attachment to report.spam@nc.gov.

Dear Division of Air Quality,

I am writing to urge DEQ to wisely invest the \$92 million in Volkswagen settlement funds in electric vehicles and infrastructure. Taking advantage of these funds to jumpstart the electrification of North Carolina's transportation sector will mean less money sent out of state for petroleum, more in-state jobs, and cleaner air.

Specifically, I recommend that DEQ allocate the maximum allowable amount (15%) of the funds for electric vehicle charging infrastructure and installations. And I encourage DEQ to prioritize electric vehicles and buses for replacement whenever possible with the other 85% of the settlement funds. Doing so will maximize the local economic impact and the reduction of air pollution.

I encourage you to not use the funding for natural gas, propane or diesel vehicles. Further dependence on fossil fuels means more pollution. Only a transition to electric vehicles and investment in EV infrastructure will put us on the road to a 100% clean transportation sector in North Carolina.

Sincerely,

Anne Jarema
8 Valle Vista Drive
Asheville, NC 28804
anne_jarema@verizon.net
(828) 505-3818

This message was sent by KnowWho, as a service provider only, on behalf of the individual noted in the sender information.

From: Jason Delborne (jdelborne@gmail.com) Sent You a Personal Message
To: [daq.NC_VWGrants](#)
Subject: [External] Use Volkswagen funds to electrify NC transportation
Date: Wednesday, December 06, 2017 9:59:19 AM

CAUTION: External email. Do not click links or open attachments unless verified. Send all suspicious email as an attachment to report.spam@nc.gov.

Dear Division of Air Quality,

I am writing to urge DEQ to wisely invest the \$92 million in Volkswagen settlement funds in electric vehicles and infrastructure. Taking advantage of these funds to jumpstart the electrification of North Carolina's transportation sector will mean less money sent out of state for petroleum, more in-state jobs, and cleaner air.

Specifically, I recommend that DEQ allocate the maximum allowable amount (15%) of the funds for electric vehicle charging infrastructure and installations. And I encourage DEQ to prioritize electric vehicles and buses for replacement whenever possible with the other 85% of the settlement funds. Doing so will maximize the local economic impact and the reduction of air pollution.

I encourage you to not use the funding for natural gas, propane or diesel vehicles. Further dependence on fossil fuels means more pollution. Only a transition to electric vehicles and investment in EV infrastructure will put us on the road to a 100% clean transportation sector in North Carolina.

Sincerely,

Jason Delborne
711 McCulloch St
Raleigh, NC 27603
jdelborne@gmail.com
(919) 980-2867

This message was sent by KnowWho, as a service provider only, on behalf of the individual noted in the sender information.

From: jutta moore (jpmoore@wcpss.net) Sent You a Personal Message
To: [daq.NC_VWGrants](#)
Subject: [External] Use Volkswagen funds to electrify NC transportation
Date: Wednesday, December 06, 2017 9:56:01 AM

CAUTION: External email. Do not click links or open attachments unless verified. Send all suspicious email as an attachment to report.spam@nc.gov.

Dear Division of Air Quality,

I am writing to urge DEQ to wisely invest the \$92 million in Volkswagen settlement funds in electric vehicles and infrastructure. Taking advantage of these funds to jumpstart the electrification of North Carolina's transportation sector will mean less money sent out of state for petroleum, more in-state jobs, and cleaner air.

Specifically, I recommend that DEQ allocate the maximum allowable amount (15%) of the funds for electric vehicle charging infrastructure and installations. And I encourage DEQ to prioritize electric vehicles and buses for replacement whenever possible with the other 85% of the settlement funds. Doing so will maximize the local economic impact and the reduction of air pollution.

I encourage you to not use the funding for natural gas, propane or diesel vehicles. Further dependence on fossil fuels means more pollution. Only a transition to electric vehicles and investment in EV infrastructure will put us on the road to a 100% clean transportation sector in North Carolina.

Sincerely,

jutta moore
2900 rannock court
raleigh, NC 27604
jpmoore@wcpss.net
(919) 850-9236

This message was sent by KnowWho, as a service provider only, on behalf of the individual noted in the sender information.

From: Mike Jarosinski (jarosinskij@bellsouth.net) Sent You a Personal Message
To: [daq.NC_VWGrants](#)
Subject: [External] Use Volkswagen funds to electrify NC transportation
Date: Wednesday, December 06, 2017 9:53:11 AM

CAUTION: External email. Do not click links or open attachments unless verified. Send all suspicious email as an attachment to report.spam@nc.gov.

Dear Division of Air Quality,

I am writing to urge DEQ to wisely invest the \$92 million in Volkswagen settlement funds in electric vehicles and infrastructure. Taking advantage of these funds to jumpstart the electrification of North Carolina's transportation sector will mean less money sent out of state for petroleum, more in-state jobs, and cleaner air.

Specifically, I recommend that DEQ allocate the maximum allowable amount (15%) of the funds for electric vehicle charging infrastructure and installations. And I encourage DEQ to prioritize electric vehicles and buses for replacement whenever possible with the other 85% of the settlement funds. Doing so will maximize the local economic impact and the reduction of air pollution.

I encourage you to not use the funding for natural gas, propane or diesel vehicles. Further dependence on fossil fuels means more pollution. Only a transition to electric vehicles and investment in EV infrastructure will put us on the road to a 100% clean transportation sector in North Carolina.

Sincerely,

Mike Jarosinski
5809 Rowsgate Ln
Wilmington, NC 28411
jarosinskij@bellsouth.net
(910) 409-7078

This message was sent by KnowWho, as a service provider only, on behalf of the individual noted in the sender information.

From: Christine Voss (christinemvoss@gmail.com) Sent You a Personal Message
To: [daq.NC_VWGrants](#)
Subject: [External] Use Volkswagen funds to electrify NC transportation
Date: Wednesday, December 06, 2017 9:51:06 AM

CAUTION: External email. Do not click links or open attachments unless verified. Send all suspicious email as an attachment to report.spam@nc.gov.

Dear Division of Air Quality,

I am writing to urge DEQ to wisely invest the \$92 million in Volkswagen settlement funds in electric vehicles and infrastructure. Taking advantage of these funds to jumpstart the electrification of North Carolina's transportation sector will mean less money sent out of state for petroleum, more in-state jobs, and cleaner air.

Specifically, I recommend that DEQ allocate the maximum allowable amount (15%) of the funds for electric vehicle charging infrastructure and installations. And I encourage DEQ to prioritize electric vehicles and buses for replacement whenever possible with the other 85% of the settlement funds. Doing so will maximize the local economic impact and the reduction of air pollution.

I encourage you to not use the funding for natural gas, propane or diesel vehicles. Further dependence on fossil fuels means more pollution. Only a transition to electric vehicles and investment in EV infrastructure will put us on the road to a 100% clean transportation sector in North Carolina.

Sincerely,

Christine Voss
106 Locust Ct
Pine Knoll Shores, NC 28512
christinemvoss@gmail.com
(252) 717-3890

This message was sent by KnowWho, as a service provider only, on behalf of the individual noted in the sender information.

From: Kristin Trangsrud (ktrangsrud@yahoo.com) Sent You a Personal Message
To: [daq.NC_VWGrants](#)
Subject: [External] Use Volkswagen funds to electrify NC transportation
Date: Wednesday, December 06, 2017 9:49:46 AM

CAUTION: External email. Do not click links or open attachments unless verified. Send all suspicious email as an attachment to report.spam@nc.gov.

Dear Division of Air Quality,

I am writing to urge DEQ to wisely invest the \$92 million in Volkswagen settlement funds in electric vehicles and infrastructure. Taking advantage of these funds to jumpstart the electrification of North Carolina's transportation sector will mean less money sent out of state for petroleum, more in-state jobs, and cleaner air.

Specifically, I recommend that DEQ allocate the maximum allowable amount (15%) of the funds for electric vehicle charging infrastructure and installations. And I encourage DEQ to prioritize electric vehicles and buses for replacement whenever possible with the other 85% of the settlement funds. Doing so will maximize the local economic impact and the reduction of air pollution.

I encourage you to not use the funding for natural gas, propane or diesel vehicles. Further dependence on fossil fuels means more pollution. Only a transition to electric vehicles and investment in EV infrastructure will put us on the road to a 100% clean transportation sector in North Carolina.

Sincerely,

Kristin Trangsrud
121 LAKE HOGAN FARM RD
CHAPEL HILL, NC 27516
ktrangsrud@yahoo.com
(919) 929-3980

This message was sent by KnowWho, as a service provider only, on behalf of the individual noted in the sender information.

From: Ron and Nancy Bryant (ronancyb@hughes.net) Sent You a Personal Message
To: [daq.NC_VWGrants](#)
Subject: [External] Use Volkswagen funds to electrify NC transportation
Date: Wednesday, December 06, 2017 9:44:36 AM

CAUTION: External email. Do not click links or open attachments unless verified. Send all suspicious email as an attachment to report.spam@nc.gov.

Dear Division of Air Quality,

I am writing to urge DEQ to wisely invest the \$92 million in Volkswagen settlement funds in electric vehicles and infrastructure. Taking advantage of these funds to jumpstart the electrification of North Carolina's transportation sector will mean less money sent out of state for petroleum, more in-state jobs, and cleaner air.

Specifically, I recommend that DEQ allocate the maximum allowable amount (15%) of the funds for electric vehicle charging infrastructure and installations. And I encourage DEQ to prioritize electric vehicles and buses for replacement whenever possible with the other 85% of the settlement funds. Doing so will maximize the local economic impact and the reduction of air pollution.

I encourage you to not use the funding for natural gas, propane or diesel vehicles. Further dependence on fossil fuels means more pollution. Only a transition to electric vehicles and investment in EV infrastructure will put us on the road to a 100% clean transportation sector in North Carolina.

Sincerely,

Ron and Nancy Bryant
5546 Old Thompson Road
Ron O., NC 28128
ronancyb@hughes.net
(704) 474-9134

This message was sent by KnowWho, as a service provider only, on behalf of the individual noted in the sender information.

From: Jason Robinson (jason@designergenes.biz) Sent You a Personal Message
To: [daq.NC_VWGrants](#)
Subject: [External] Use Volkswagen funds to electrify NC transportation
Date: Wednesday, December 06, 2017 9:42:33 AM

CAUTION: External email. Do not click links or open attachments unless verified. Send all suspicious email as an attachment to report.spam@nc.gov.

Dear Division of Air Quality,

I am writing to urge DEQ to wisely invest the \$92 million in Volkswagen settlement funds in electric vehicles and infrastructure. Taking advantage of these funds to jumpstart the electrification of North Carolina's transportation sector will mean less money sent out of state for petroleum, more in-state jobs, and cleaner air.

Specifically, I recommend that DEQ allocate the maximum allowable amount (15%) of the funds for electric vehicle charging infrastructure and installations. And I encourage DEQ to prioritize electric vehicles and buses for replacement whenever possible with the other 85% of the settlement funds. Doing so will maximize the local economic impact and the reduction of air pollution.

I encourage you to not use the funding for natural gas, propane or diesel vehicles. Further dependence on fossil fuels means more pollution. Only a transition to electric vehicles and investment in EV infrastructure will put us on the road to a 100% clean transportation sector in North Carolina.

Sincerely,

Jason Robinson
3908 Delgany Drive
Charlotte, NC 28215
jason@designergenes.biz
(704) 910-0113

This message was sent by KnowWho, as a service provider only, on behalf of the individual noted in the sender information.

From: Robert M. Wilson (rmwilson476@gmail.com) Sent You a Personal Message
To: [daq.NC_VWGrants](#)
Subject: [External] Use Volkswagen funds to electrify NC transportation
Date: Wednesday, December 06, 2017 9:41:02 AM

CAUTION: External email. Do not click links or open attachments unless verified. Send all suspicious email as an attachment to report.spam@nc.gov.

Dear Division of Air Quality,

I am writing to urge DEQ to wisely invest the \$92 million in Volkswagen settlement funds in electric vehicles and infrastructure. Taking advantage of these funds to jumpstart the electrification of North Carolina's transportation sector will mean less money sent out of state for petroleum, more in-state jobs, and cleaner air.

Specifically, I recommend that DEQ allocate the maximum allowable amount (15%) of the funds for electric vehicle charging infrastructure and installations. And I encourage DEQ to prioritize electric vehicles and buses for replacement whenever possible with the other 85% of the settlement funds. Doing so will maximize the local economic impact and the reduction of air pollution.

I encourage you to not use the funding for natural gas, propane or diesel vehicles. Further dependence on fossil fuels means more pollution. Only a transition to electric vehicles and investment in EV infrastructure will put us on the road to a 100% clean transportation sector in North Carolina.

Sincerely,

Robert M. Wilson
476 Ivy Hill Road
Marshall, NC 28753
rmwilson476@gmail.com
(828) 279-0001

This message was sent by KnowWho, as a service provider only, on behalf of the individual noted in the sender information.

From: Michele Clark (uncmicha@gmail.com) Sent You a Personal Message
To: [daq.NC_VWGrants](#)
Subject: [External] Use Volkswagen funds to electrify NC transportation
Date: Wednesday, December 06, 2017 9:40:21 AM

CAUTION: External email. Do not click links or open attachments unless verified. Send all suspicious email as an attachment to report.spam@nc.gov.

Dear Division of Air Quality,

I am writing to urge DEQ to wisely invest the \$92 million in Volkswagen settlement funds in electric vehicles and infrastructure. Taking advantage of these funds to jumpstart the electrification of North Carolina's transportation sector will mean less money sent out of state for petroleum, more in-state jobs, and cleaner air.

Specifically, I recommend that DEQ allocate the maximum allowable amount (15%) of the funds for electric vehicle charging infrastructure and installations. And I encourage DEQ to prioritize electric vehicles and buses for replacement whenever possible with the other 85% of the settlement funds. Doing so will maximize the local economic impact and the reduction of air pollution.

I encourage you to not use the funding for natural gas, propane or diesel vehicles. Further dependence on fossil fuels means more pollution. Only a transition to electric vehicles and investment in EV infrastructure will put us on the road to a 100% clean transportation sector in North Carolina.

Sincerely,

Michele Clark
109 Shadowood Dr. Apt. V
Chapel Hill, NC 27514
uncmicha@gmail.com
(919) 260-0895

This message was sent by KnowWho, as a service provider only, on behalf of the individual noted in the sender information.

From: Cody Hulme (cody.hulme@gmail.com) Sent You a Personal Message
To: [daq.NC_VWGrants](#)
Subject: [External] Use Volkswagen funds to electrify NC transportation
Date: Wednesday, December 06, 2017 9:39:33 AM

CAUTION: External email. Do not click links or open attachments unless verified. Send all suspicious email as an attachment to report.spam@nc.gov.

Dear Division of Air Quality,

I am writing to urge DEQ to wisely invest the \$92 million in Volkswagen settlement funds in electric vehicles and infrastructure. Taking advantage of these funds to jumpstart the electrification of North Carolina's transportation sector will mean less money sent out of state for petroleum, more in-state jobs, and cleaner air.

Specifically, I recommend that DEQ allocate the maximum allowable amount (15%) of the funds for electric vehicle charging infrastructure and installations. And I encourage DEQ to prioritize electric vehicles and buses for replacement whenever possible with the other 85% of the settlement funds. Doing so will maximize the local economic impact and the reduction of air pollution.

I encourage you to not use the funding for natural gas, propane or diesel vehicles. Further dependence on fossil fuels means more pollution. Only a transition to electric vehicles and investment in EV infrastructure will put us on the road to a 100% clean transportation sector in North Carolina.

Sincerely,

Cody Hulme
110 North Forest Lane
Cody, NC 28804
cody.hulme@gmail.com
(828) 777-5235

This message was sent by KnowWho, as a service provider only, on behalf of the individual noted in the sender information.

From: Frank Lorch (franklorch@yahoo.com) Sent You a Personal Message
To: [daq.NC_VWGrants](#)
Subject: [External] Use Volkswagen funds to electrify NC transportation
Date: Wednesday, December 06, 2017 9:38:25 AM

CAUTION: External email. Do not click links or open attachments unless verified. Send all suspicious email as an attachment to report.spam@nc.gov.

Dear Division of Air Quality,

I am writing to urge DEQ to wisely invest the \$92 million in Volkswagen settlement funds in electric vehicles and infrastructure. Taking advantage of these funds to jumpstart the electrification of North Carolina's transportation sector will mean less money sent out of state for petroleum, more in-state jobs, and cleaner air.

Specifically, I recommend that DEQ allocate the maximum allowable amount (15%) of the funds for electric vehicle charging infrastructure and installations. And I encourage DEQ to prioritize electric vehicles and buses for replacement whenever possible with the other 85% of the settlement funds. Doing so will maximize the local economic impact and the reduction of air pollution.

I encourage you to not use the funding for natural gas, propane or diesel vehicles. Further dependence on fossil fuels means more pollution. Only a transition to electric vehicles and investment in EV infrastructure will put us on the road to a 100% clean transportation sector in North Carolina.

Sincerely,

Frank Lorch
2885 Sanford Ave. SW #41063
Grandville, MI 49418
franklorch@yahoo.com
(704) 907-0760

This message was sent by KnowWho, as a service provider only, on behalf of the individual noted in the sender information.

From: Ulrich Alsentzer (ualsentzer@gotricounty.com) Sent You a Personal Message
To: daq.NC_VWGrants
Subject: [External] Use Volkswagen funds to electrify NC transportation
Date: Wednesday, December 06, 2017 9:35:38 AM

CAUTION: External email. Do not click links or open attachments unless verified. Send all suspicious email as an attachment to report.spam@nc.gov.

Dear Division of Air Quality,

I am writing to urge DEQ to wisely invest the \$92 million in Volkswagen settlement funds in electric vehicles and infrastructure. Taking advantage of these funds to jumpstart the electrification of North Carolina's transportation sector will mean less money sent out of state for petroleum, more in-state jobs, and cleaner air.

Specifically, I recommend that DEQ allocate the maximum allowable amount (15%) of the funds for electric vehicle charging infrastructure and installations. And I encourage DEQ to prioritize electric vehicles and buses for replacement whenever possible with the other 85% of the settlement funds. Doing so will maximize the local economic impact and the reduction of air pollution.

I encourage you to not use the funding for natural gas, propane or diesel vehicles. Further dependence on fossil fuels means more pollution. Only a transition to electric vehicles and investment in EV infrastructure will put us on the road to a 100% clean transportation sector in North Carolina.

Sincerely,

Ulrich Alsentzer
103 Cabana Rd
Ulrich, NC 27810
ualsentzer@gotricounty.com
(252) 964-4624

This message was sent by KnowWho, as a service provider only, on behalf of the individual noted in the sender information.

From: Richard Klett (richardklett@gmail.com) Sent You a Personal Message
To: [daq.NC_VWGrants](#)
Subject: [External] Use Volkswagen funds to electrify NC transportation
Date: Wednesday, December 06, 2017 9:33:08 AM

CAUTION: External email. Do not click links or open attachments unless verified. Send all suspicious email as an attachment to report.spam@nc.gov.

Dear Division of Air Quality,

I am writing to urge DEQ to wisely invest the \$92 million in Volkswagen settlement funds in electric vehicles and infrastructure. Taking advantage of these funds to jumpstart the electrification of North Carolina's transportation sector will mean less money sent out of state for petroleum, more in-state jobs, and cleaner air.

Specifically, I recommend that DEQ allocate the maximum allowable amount (15%) of the funds for electric vehicle charging infrastructure and installations. And I encourage DEQ to prioritize electric vehicles and buses for replacement whenever possible with the other 85% of the settlement funds. Doing so will maximize the local economic impact and the reduction of air pollution.

I encourage you to not use the funding for natural gas, propane or diesel vehicles. Further dependence on fossil fuels means more pollution. Only a transition to electric vehicles and investment in EV infrastructure will put us on the road to a 100% clean transportation sector in North Carolina.

Sincerely,

Richard Klett
4245 little fork cove rd
Denver, NC 28037
richardklett@gmail.com
(703) 380-1023

This message was sent by KnowWho, as a service provider only, on behalf of the individual noted in the sender information.

From: Leah DeKoskie (leahdekoskie@me.com) Sent You a Personal Message
To: [daq.NC_VWGrants](#)
Subject: [External] Use Volkswagen funds to electrify NC transportation
Date: Wednesday, December 06, 2017 9:33:07 AM

CAUTION: External email. Do not click links or open attachments unless verified. Send all suspicious email as an attachment to report.spam@nc.gov.

Dear Division of Air Quality,

I am writing to urge DEQ to wisely invest the \$92 million in Volkswagen settlement funds in electric vehicles and infrastructure. Taking advantage of these funds to jumpstart the electrification of North Carolina's transportation sector will mean less money sent out of state for petroleum, more in-state jobs, and cleaner air.

Specifically, I recommend that DEQ allocate the maximum allowable amount (15%) of the funds for electric vehicle charging infrastructure and installations. And I encourage DEQ to prioritize electric vehicles and buses for replacement whenever possible with the other 85% of the settlement funds. Doing so will maximize the local economic impact and the reduction of air pollution.

I encourage you to not use the funding for natural gas, propane or diesel vehicles. Further dependence on fossil fuels means more pollution. Only a transition to electric vehicles and investment in EV infrastructure will put us on the road to a 100% clean transportation sector in North Carolina.

Sincerely,

Leah DeKoskie
605 Culvert St
Leah, NC 27502
leahdekoskie@me.com
(678) 313-6298

This message was sent by KnowWho, as a service provider only, on behalf of the individual noted in the sender information.

From: Chris Gully (gullyc@yahoo.com) Sent You a Personal Message
To: [daq.NC_VWGrants](#)
Subject: [External] Use Volkswagen funds to electrify NC transportation
Date: Wednesday, December 06, 2017 9:33:02 AM

CAUTION: External email. Do not click links or open attachments unless verified. Send all suspicious email as an attachment to report.spam@nc.gov.

Dear Division of Air Quality,

I am writing to urge DEQ to wisely invest the \$92 million in Volkswagen settlement funds in electric vehicles and infrastructure. Taking advantage of these funds to jumpstart the electrification of North Carolina's transportation sector will mean less money sent out of state for petroleum, more in-state jobs, and cleaner air.

Specifically, I recommend that DEQ allocate the maximum allowable amount (15%) of the funds for electric vehicle charging infrastructure and installations. And I encourage DEQ to prioritize electric vehicles and buses for replacement whenever possible with the other 85% of the settlement funds. Doing so will maximize the local economic impact and the reduction of air pollution.

I encourage you to not use the funding for natural gas, propane or diesel vehicles. Further dependence on fossil fuels means more pollution. Only a transition to electric vehicles and investment in EV infrastructure will put us on the road to a 100% clean transportation sector in North Carolina.

Sincerely,

Chris Gully
103 bellshill ct
cary, NC 27513
gullyc@yahoo.com
(913) 800-1220

This message was sent by KnowWho, as a service provider only, on behalf of the individual noted in the sender information.

From: Maryanne Rackoff (maryannerackoff@yahoo.com) Sent You a Personal Message
To: [daq.NC_VWGrants](#)
Subject: [External] Use Volkswagen funds to electrify NC transportation
Date: Wednesday, December 06, 2017 9:23:12 AM

CAUTION: External email. Do not click links or open attachments unless verified. Send all suspicious email as an attachment to report.spam@nc.gov.

Dear Division of Air Quality,

I am writing to urge DEQ to wisely invest the \$92 million in Volkswagen settlement funds in electric vehicles and infrastructure. Taking advantage of these funds to jumpstart the electrification of North Carolina's transportation sector will mean less money sent out of state for petroleum, more in-state jobs, and cleaner air.

Specifically, I recommend that DEQ allocate the maximum allowable amount (15%) of the funds for electric vehicle charging infrastructure and installations. And I encourage DEQ to prioritize electric vehicles and buses for replacement whenever possible with the other 85% of the settlement funds. Doing so will maximize the local economic impact and the reduction of air pollution.

I encourage you to not use the funding for natural gas, propane or diesel vehicles. Further dependence on fossil fuels means more pollution. Only a transition to electric vehicles and investment in EV infrastructure will put us on the road to a 100% clean transportation sector in North Carolina.

Sincerely,

Maryanne Rackoff
45 Tree Top Dr
Arden, NC 28704
maryannerackoff@yahoo.com
(330) 701-5574

This message was sent by KnowWho, as a service provider only, on behalf of the individual noted in the sender information.

From: Cameron Riddle (criddle@caldwellschools.com) Sent You a Personal Message
To: [daq.NC_VWGrants](#)
Subject: [External] Use Volkswagen funds to electrify NC transportation
Date: Wednesday, December 06, 2017 9:09:57 AM

CAUTION: External email. Do not click links or open attachments unless verified. Send all suspicious email as an attachment to report.spam@nc.gov.

Dear Division of Air Quality,

I am writing to urge DEQ to wisely invest the \$92 million in Volkswagen settlement funds in electric vehicles and infrastructure. Taking advantage of these funds to jumpstart the electrification of North Carolina's transportation sector will mean less money sent out of state for petroleum, more in-state jobs, and cleaner air.

Specifically, I recommend that DEQ allocate the maximum allowable amount (15%) of the funds for electric vehicle charging infrastructure and installations. And I encourage DEQ to prioritize electric vehicles and buses for replacement whenever possible with the other 85% of the settlement funds. Doing so will maximize the local economic impact and the reduction of air pollution.

I encourage you to not use the funding for natural gas, propane or diesel vehicles. Further dependence on fossil fuels means more pollution. Only a transition to electric vehicles and investment in EV infrastructure will put us on the road to a 100% clean transportation sector in North Carolina.

Sincerely,

Cameron Riddle
1111 Brockmore Dr
Lenoir, NC 28645
criddle@caldwellschools.com
(828) 754-7411

This message was sent by KnowWho, as a service provider only, on behalf of the individual noted in the sender information.

From: Eva Duggins (eduggins@embarqmail.com) Sent You a Personal Message
To: [daq.NC_VWGrants](#)
Subject: [External] Use Volkswagen funds to electrify NC transportation
Date: Wednesday, December 06, 2017 9:09:55 AM

CAUTION: External email. Do not click links or open attachments unless verified. Send all suspicious email as an attachment to report.spam@nc.gov.

Dear Division of Air Quality,

I am writing to urge DEQ to wisely invest the \$92 million in Volkswagen settlement funds in electric vehicles and infrastructure. Taking advantage of these funds to jumpstart the electrification of North Carolina's transportation sector will mean less money sent out of state for petroleum, more in-state jobs, and cleaner air.

Specifically, I recommend that DEQ allocate the maximum allowable amount (15%) of the funds for electric vehicle charging infrastructure and installations. And I encourage DEQ to prioritize electric vehicles and buses for replacement whenever possible with the other 85% of the settlement funds. Doing so will maximize the local economic impact and the reduction of air pollution.

I encourage you to not use the funding for natural gas, propane or diesel vehicles. Further dependence on fossil fuels means more pollution. Only a transition to electric vehicles and investment in EV infrastructure will put us on the road to a 100% clean transportation sector in North Carolina.

Sincerely,

Eva Duggins
2212 NC Hwy 731 W
Mt. Gilead, NC 27306
eduggins@embarqmail.com
(910) 439-1690

This message was sent by KnowWho, as a service provider only, on behalf of the individual noted in the sender information.

From: Robert McCarthy (mca1970@aol.com) Sent You a Personal Message
To: [daq.NC_VWGrants](#)
Subject: [External] Use Volkswagen funds to electrify NC transportation
Date: Wednesday, December 06, 2017 9:09:40 AM

CAUTION: External email. Do not click links or open attachments unless verified. Send all suspicious email as an attachment to report.spam@nc.gov.

Dear Division of Air Quality,

I am writing to urge DEQ to wisely invest the \$92 million in Volkswagen settlement funds in electric vehicles and infrastructure. Taking advantage of these funds to jumpstart the electrification of North Carolina's transportation sector will mean less money sent out of state for petroleum, more in-state jobs, and cleaner air.

Specifically, I recommend that DEQ allocate the maximum allowable amount (15%) of the funds for electric vehicle charging infrastructure and installations. And I encourage DEQ to prioritize electric vehicles and buses for replacement whenever possible with the other 85% of the settlement funds. Doing so will maximize the local economic impact and the reduction of air pollution.

I encourage you to not use the funding for natural gas, propane or diesel vehicles. Further dependence on fossil fuels means more pollution. Only a transition to electric vehicles and investment in EV infrastructure will put us on the road to a 100% clean transportation sector in North Carolina.

Sincerely,

Robert McCarthy
9660 Sievers Way NW
Ash, NC 28420
mca1970@aol.com
(843) 267-2464

This message was sent by KnowWho, as a service provider only, on behalf of the individual noted in the sender information.

From: James Kelbaugh (jimlouk@att.net) Sent You a Personal Message
To: [daq.NC_VWGrants](#)
Subject: [External] Use Volkswagen funds to electrify NC transportation
Date: Wednesday, December 06, 2017 9:04:59 AM

CAUTION: External email. Do not click links or open attachments unless verified. Send all suspicious email as an attachment to report.spam@nc.gov.

Dear Division of Air Quality,

I am writing to urge DEQ to wisely invest the \$92 million in Volkswagen settlement funds in electric vehicles and infrastructure. Taking advantage of these funds to jumpstart the electrification of North Carolina's transportation sector will mean less money sent out of state for petroleum, more in-state jobs, and cleaner air.

Specifically, I recommend that DEQ allocate the maximum allowable amount (15%) of the funds for electric vehicle charging infrastructure and installations. And I encourage DEQ to prioritize electric vehicles and buses for replacement whenever possible with the other 85% of the settlement funds. Doing so will maximize the local economic impact and the reduction of air pollution.

I encourage you to not use the funding for natural gas, propane or diesel vehicles. Further dependence on fossil fuels means more pollution. Only a transition to electric vehicles and investment in EV infrastructure will put us on the road to a 100% clean transportation sector in North Carolina.

Sincerely,

James Kelbaugh
733 Plantation Estates Dr., Apt. C103
Matthews, NC 28105
jimlouk@att.net
(704) 321-5127

This message was sent by KnowWho, as a service provider only, on behalf of the individual noted in the sender information.

From: Tiffany Hartung (tiffanyhartung@gmail.com) Sent You a Personal Message
To: [daq.NC_VWGrants](#)
Subject: [External] Use Volkswagen funds to electrify NC transportation
Date: Wednesday, December 06, 2017 8:59:00 AM

CAUTION: External email. Do not click links or open attachments unless verified. Send all suspicious email as an attachment to report.spam@nc.gov.

Dear Division of Air Quality,

I am writing to urge DEQ to wisely invest the \$92 million in Volkswagen settlement funds in electric vehicles and infrastructure. Taking advantage of these funds to jumpstart the electrification of North Carolina's transportation sector will mean less money sent out of state for petroleum, more in-state jobs, and cleaner air.

Specifically, I recommend that DEQ allocate the maximum allowable amount (15%) of the funds for electric vehicle charging infrastructure and installations. And I encourage DEQ to prioritize electric vehicles and buses for replacement whenever possible with the other 85% of the settlement funds. Doing so will maximize the local economic impact and the reduction of air pollution.

I encourage you to not use the funding for natural gas, propane or diesel vehicles. Further dependence on fossil fuels means more pollution. Only a transition to electric vehicles and investment in EV infrastructure will put us on the road to a 100% clean transportation sector in North Carolina.

Sincerely,

Tiffany Hartung
5217 Stanley Rd
Durham, NC 27704
tiffanyhartung@gmail.com
(248) 933-2451

This message was sent by KnowWho, as a service provider only, on behalf of the individual noted in the sender information.

From: Kristina Heiks (kheiks@yahoo.com) Sent You a Personal Message
To: [daq.NC_VWGrants](#)
Subject: [External] Use Volkswagen funds to electrify NC transportation
Date: Wednesday, December 06, 2017 8:57:25 AM

CAUTION: External email. Do not click links or open attachments unless verified. Send all suspicious email as an attachment to report.spam@nc.gov.

Dear Division of Air Quality,

I am writing to urge DEQ to wisely invest the \$92 million in Volkswagen settlement funds in electric vehicles and infrastructure. Taking advantage of these funds to jumpstart the electrification of North Carolina's transportation sector will mean less money sent out of state for petroleum, more in-state jobs, and cleaner air.

Specifically, I recommend that DEQ allocate the maximum allowable amount (15%) of the funds for electric vehicle charging infrastructure and installations. And I encourage DEQ to prioritize electric vehicles and buses for replacement whenever possible with the other 85% of the settlement funds. Doing so will maximize the local economic impact and the reduction of air pollution.

I encourage you to not use the funding for natural gas, propane or diesel vehicles. Further dependence on fossil fuels means more pollution. Only a transition to electric vehicles and investment in EV infrastructure will put us on the road to a 100% clean transportation sector in North Carolina.

Sincerely,

Kristina Heiks
2786 NC Hwy 194 N
Boone, NC 28607
kheiks@yahoo.com
(828) 264-9230

This message was sent by KnowWho, as a service provider only, on behalf of the individual noted in the sender information.

From: Lisa Baker (lisabaker72@gmail.com) Sent You a Personal Message
To: [daq.NC_VWGrants](#)
Subject: [External] Use Volkswagen funds to electrify NC transportation
Date: Wednesday, December 06, 2017 8:57:11 AM

CAUTION: External email. Do not click links or open attachments unless verified. Send all suspicious email as an attachment to report.spam@nc.gov.

Dear Division of Air Quality,

I am writing to urge DEQ to wisely invest the \$92 million in Volkswagen settlement funds in electric vehicles and infrastructure. Taking advantage of these funds to jumpstart the electrification of North Carolina's transportation sector will mean less money sent out of state for petroleum, more in-state jobs, and cleaner air.

Specifically, I recommend that DEQ allocate the maximum allowable amount (15%) of the funds for electric vehicle charging infrastructure and installations. And I encourage DEQ to prioritize electric vehicles and buses for replacement whenever possible with the other 85% of the settlement funds. Doing so will maximize the local economic impact and the reduction of air pollution.

I encourage you to not use the funding for natural gas, propane or diesel vehicles. Further dependence on fossil fuels means more pollution. Only a transition to electric vehicles and investment in EV infrastructure will put us on the road to a 100% clean transportation sector in North Carolina.

Sincerely,

Lisa Baker
3C Hedgerose Court
Asheville, NC 28805
lisabaker72@gmail.com
(828) 707-6807

This message was sent by KnowWho, as a service provider only, on behalf of the individual noted in the sender information.

From: Jan Parkinson (jparkinson7@yahoo.com) Sent You a Personal Message
To: [daq.NC_VWGrants](#)
Subject: [External] Use Volkswagen funds to electrify NC transportation
Date: Wednesday, December 06, 2017 8:54:26 AM

CAUTION: External email. Do not click links or open attachments unless verified. Send all suspicious email as an attachment to report.spam@nc.gov.

Dear Division of Air Quality,

I am writing to urge DEQ to wisely invest the \$92 million in Volkswagen settlement funds in electric vehicles and infrastructure. Taking advantage of these funds to jumpstart the electrification of North Carolina's transportation sector will mean less money sent out of state for petroleum, more in-state jobs, and cleaner air.

Specifically, I recommend that DEQ allocate the maximum allowable amount (15%) of the funds for electric vehicle charging infrastructure and installations. And I encourage DEQ to prioritize electric vehicles and buses for replacement whenever possible with the other 85% of the settlement funds. Doing so will maximize the local economic impact and the reduction of air pollution.

I encourage you to not use the funding for natural gas, propane or diesel vehicles. Further dependence on fossil fuels means more pollution. Only a transition to electric vehicles and investment in EV infrastructure will put us on the road to a 100% clean transportation sector in North Carolina.

Sincerely,

Jan Parkinson
146 Eller Cove Road
Weaverville, NC 28787
jparkinson7@yahoo.com
(828) 412-8518

This message was sent by KnowWho, as a service provider only, on behalf of the individual noted in the sender information.

From: Gary Feimster (georgef7373@gmail.com) Sent You a Personal Message
To: [daq.NC_VWGrants](#)
Subject: [External] Use Volkswagen funds to electrify NC transportation
Date: Wednesday, December 06, 2017 8:51:36 AM

CAUTION: External email. Do not click links or open attachments unless verified. Send all suspicious email as an attachment to report.spam@nc.gov.

Dear Division of Air Quality,

I am writing to urge DEQ to wisely invest the \$92 million in Volkswagen settlement funds in electric vehicles and infrastructure. Taking advantage of these funds to jumpstart the electrification of North Carolina's transportation sector will mean less money sent out of state for petroleum, more in-state jobs, and cleaner air.

Specifically, I recommend that DEQ allocate the maximum allowable amount (15%) of the funds for electric vehicle charging infrastructure and installations. And I encourage DEQ to prioritize electric vehicles and buses for replacement whenever possible with the other 85% of the settlement funds. Doing so will maximize the local economic impact and the reduction of air pollution.

I encourage you to not use the funding for natural gas, propane or diesel vehicles. Further dependence on fossil fuels means more pollution. Only a transition to electric vehicles and investment in EV infrastructure will put us on the road to a 100% clean transportation sector in North Carolina.

Sincerely,

Gary Feimster
845 Graham Loop Rd
Mt. Ulla, NC 28125
georgef7373@gmail.com
(704) 550-1895

This message was sent by KnowWho, as a service provider only, on behalf of the individual noted in the sender information.

From: Ann Chelminski (anewchel@gmail.com) Sent You a Personal Message
To: [daq.NC_VWGrants](#)
Subject: [External] Use Volkswagen funds to electrify NC transportation
Date: Wednesday, December 06, 2017 8:51:24 AM

CAUTION: External email. Do not click links or open attachments unless verified. Send all suspicious email as an attachment to report.spam@nc.gov.

Dear Division of Air Quality,

I am writing to urge DEQ to wisely invest the \$92 million in Volkswagen settlement funds in electric vehicles and infrastructure. Taking advantage of these funds to jumpstart the electrification of North Carolina's transportation sector will mean less money sent out of state for petroleum, more in-state jobs, and cleaner air.

Specifically, I recommend that DEQ allocate the maximum allowable amount (15%) of the funds for electric vehicle charging infrastructure and installations. And I encourage DEQ to prioritize electric vehicles and buses for replacement whenever possible with the other 85% of the settlement funds. Doing so will maximize the local economic impact and the reduction of air pollution.

I encourage you to not use the funding for natural gas, propane or diesel vehicles. Further dependence on fossil fuels means more pollution. Only a transition to electric vehicles and investment in EV infrastructure will put us on the road to a 100% clean transportation sector in North Carolina.

Sincerely,

Ann Chelminski
116 Watters Road
Carrboro, NC 27510
anewchel@gmail.com
(919) 548-4836

This message was sent by KnowWho, as a service provider only, on behalf of the individual noted in the sender information.

From: Ed Turley (kagnew6770@gmail.com) Sent You a Personal Message
To: [daq.NC_VWGrants](#)
Subject: [External] Use Volkswagen funds to electrify NC transportation
Date: Wednesday, December 06, 2017 8:41:23 AM

CAUTION: External email. Do not click links or open attachments unless verified. Send all suspicious email as an attachment to report.spam@nc.gov.

Dear Division of Air Quality,

I am writing to urge DEQ to wisely invest the \$92 million in Volkswagen settlement funds in electric vehicles and infrastructure. Taking advantage of these funds to jumpstart the electrification of North Carolina's transportation sector will mean less money sent out of state for petroleum, more in-state jobs, and cleaner air.

Specifically, I recommend that DEQ allocate the maximum allowable amount (15%) of the funds for electric vehicle charging infrastructure and installations. And I encourage DEQ to prioritize electric vehicles and buses for replacement whenever possible with the other 85% of the settlement funds. Doing so will maximize the local economic impact and the reduction of air pollution.

I encourage you to not use the funding for natural gas, propane or diesel vehicles. Further dependence on fossil fuels means more pollution. Only a transition to electric vehicles and investment in EV infrastructure will put us on the road to a 100% clean transportation sector in North Carolina.

Sincerely,

Ed Turley
6 Shakespeare Cir
Black Mountain, NC 02871
kagnew6770@gmail.com
(828) 357-8476

This message was sent by KnowWho, as a service provider only, on behalf of the individual noted in the sender information.

From: Dan Burns (danburnsnc@gmail.com) Sent You a Personal Message
To: [daq.NC_VWGrants](#)
Subject: [External] Use Volkswagen funds to electrify NC transportation
Date: Wednesday, December 06, 2017 8:40:12 AM

CAUTION: External email. Do not click links or open attachments unless verified. Send all suspicious email as an attachment to report.spam@nc.gov.

Dear Division of Air Quality,

I am writing to urge DEQ to wisely invest the \$92 million in Volkswagen settlement funds in electric vehicles and infrastructure. Taking advantage of these funds to jumpstart the electrification of North Carolina's transportation sector will mean less money sent out of state for petroleum, more in-state jobs, and cleaner air.

Specifically, I recommend that DEQ allocate the maximum allowable amount (15%) of the funds for electric vehicle charging infrastructure and installations. And I encourage DEQ to prioritize electric vehicles and buses for replacement whenever possible with the other 85% of the settlement funds. Doing so will maximize the local economic impact and the reduction of air pollution.

I encourage you to not use the funding for natural gas, propane or diesel vehicles. Further dependence on fossil fuels means more pollution. Only a transition to electric vehicles and investment in EV infrastructure will put us on the road to a 100% clean transportation sector in North Carolina.

Sincerely,

Dan Burns
104 Dowington LN
Dan, NC 27519
danburnsnc@gmail.com
(919) 651-9790

This message was sent by KnowWho, as a service provider only, on behalf of the individual noted in the sender information.

From: Larissa Bowman (mtnvetpath@gmail.com) Sent You a Personal Message
To: [daq.NC_VWGrants](#)
Subject: [External] Use Volkswagen funds to electrify NC transportation
Date: Wednesday, December 06, 2017 8:38:32 AM

CAUTION: External email. Do not click links or open attachments unless verified. Send all suspicious email as an attachment to report.spam@nc.gov.

Dear Division of Air Quality,

I am writing to urge DEQ to wisely invest the \$92 million in Volkswagen settlement funds in electric vehicles and infrastructure. Taking advantage of these funds to jumpstart the electrification of North Carolina's transportation sector will mean less money sent out of state for petroleum, more in-state jobs, and cleaner air.

Specifically, I recommend that DEQ allocate the maximum allowable amount (15%) of the funds for electric vehicle charging infrastructure and installations. And I encourage DEQ to prioritize electric vehicles and buses for replacement whenever possible with the other 85% of the settlement funds. Doing so will maximize the local economic impact and the reduction of air pollution.

I encourage you to not use the funding for natural gas, propane or diesel vehicles. Further dependence on fossil fuels means more pollution. Only a transition to electric vehicles and investment in EV infrastructure will put us on the road to a 100% clean transportation sector in North Carolina.

Sincerely,

Larissa Bowman
425 Flat Top Mtn Rd
Fairview, NC 28730
mtnvetpath@gmail.com
(828) 670-8327

This message was sent by KnowWho, as a service provider only, on behalf of the individual noted in the sender information.

From: Alice Stack (a_stack@windstream.net) Sent You a Personal Message
To: daq.NC_VWGrants
Subject: [External] Use Volkswagen funds to electrify NC transportation
Date: Wednesday, December 06, 2017 8:35:16 AM

CAUTION: External email. Do not click links or open attachments unless verified. Send all suspicious email as an attachment to report.spam@nc.gov.

Dear Division of Air Quality,

I am writing to urge DEQ to wisely invest the \$92 million in Volkswagen settlement funds in electric vehicles and infrastructure. Taking advantage of these funds to jumpstart the electrification of North Carolina's transportation sector will mean less money sent out of state for petroleum, more in-state jobs, and cleaner air.

Specifically, I recommend that DEQ allocate the maximum allowable amount (15%) of the funds for electric vehicle charging infrastructure and installations. And I encourage DEQ to prioritize electric vehicles and buses for replacement whenever possible with the other 85% of the settlement funds. Doing so will maximize the local economic impact and the reduction of air pollution.

I encourage you to not use the funding for natural gas, propane or diesel vehicles. Further dependence on fossil fuels means more pollution. Only a transition to electric vehicles and investment in EV infrastructure will put us on the road to a 100% clean transportation sector in North Carolina.

Sincerely,

Alice Stack
5721 Fox Chase Drive
Winston-Salem, NC 27105
a_stack@windstream.net
(336) 842-9784

This message was sent by KnowWho, as a service provider only, on behalf of the individual noted in the sender information.

From: Paul Bartholic (paulbartholic@gmail.com) Sent You a Personal Message
To: [daq.NC_VWGrants](#)
Subject: [External] Use Volkswagen funds to electrify NC transportation
Date: Wednesday, December 06, 2017 8:34:46 AM

CAUTION: External email. Do not click links or open attachments unless verified. Send all suspicious email as an attachment to report.spam@nc.gov.

Dear Division of Air Quality,

I am writing to urge DEQ to wisely invest the \$92 million in Volkswagen settlement funds in electric vehicles and infrastructure. Taking advantage of these funds to jumpstart the electrification of North Carolina's transportation sector will mean less money sent out of state for petroleum, more in-state jobs, and cleaner air.

Specifically, I recommend that DEQ allocate the maximum allowable amount (15%) of the funds for electric vehicle charging infrastructure and installations. And I encourage DEQ to prioritize electric vehicles and buses for replacement whenever possible with the other 85% of the settlement funds. Doing so will maximize the local economic impact and the reduction of air pollution.

I encourage you to not use the funding for natural gas, propane or diesel vehicles. Further dependence on fossil fuels means more pollution. Only a transition to electric vehicles and investment in EV infrastructure will put us on the road to a 100% clean transportation sector in North Carolina.

Sincerely,

Paul Bartholic
83 Westwood Place
Asheville, NC 28806
paulbartholic@gmail.com
(828) 320-1234

This message was sent by KnowWho, as a service provider only, on behalf of the individual noted in the sender information.

From: Tanya Manning (aschman13@gmail.com) Sent You a Personal Message
To: daq.NC_VWGrants
Subject: [External] Use Volkswagen funds to electrify NC transportation
Date: Wednesday, December 06, 2017 8:30:17 AM

CAUTION: External email. Do not click links or open attachments unless verified. Send all suspicious email as an attachment to report.spam@nc.gov.

Dear Division of Air Quality,

I am writing to urge DEQ to wisely invest the \$92 million in Volkswagen settlement funds in electric vehicles and infrastructure. Taking advantage of these funds to jumpstart the electrification of North Carolina's transportation sector will mean less money sent out of state for petroleum, more in-state jobs, and cleaner air.

Specifically, I recommend that DEQ allocate the maximum allowable amount (15%) of the funds for electric vehicle charging infrastructure and installations. And I encourage DEQ to prioritize electric vehicles and buses for replacement whenever possible with the other 85% of the settlement funds. Doing so will maximize the local economic impact and the reduction of air pollution.

I encourage you to not use the funding for natural gas, propane or diesel vehicles. Further dependence on fossil fuels means more pollution. Only a transition to electric vehicles and investment in EV infrastructure will put us on the road to a 100% clean transportation sector in North Carolina.

Sincerely,

Tanya Manning
PO Box 632
Brevard, NC 28712
aschman13@gmail.com
(352) 543-6573

This message was sent by KnowWho, as a service provider only, on behalf of the individual noted in the sender information.

From: Donna Durfee (dddurfee@msn.com) Sent You a Personal Message
To: [daq.NC_VWGrants](#)
Subject: [External] Use Volkswagen funds to electrify NC transportation
Date: Wednesday, December 06, 2017 8:27:56 AM

CAUTION: External email. Do not click links or open attachments unless verified. Send all suspicious email as an attachment to report.spam@nc.gov.

Dear Division of Air Quality,

I am writing to urge DEQ to wisely invest the \$92 million in Volkswagen settlement funds in electric vehicles and infrastructure. Taking advantage of these funds to jumpstart the electrification of North Carolina's transportation sector will mean less money sent out of state for petroleum, more in-state jobs, and cleaner air.

Specifically, I recommend that DEQ allocate the maximum allowable amount (15%) of the funds for electric vehicle charging infrastructure and installations. And I encourage DEQ to prioritize electric vehicles and buses for replacement whenever possible with the other 85% of the settlement funds. Doing so will maximize the local economic impact and the reduction of air pollution.

I encourage you to not use the funding for natural gas, propane or diesel vehicles. Further dependence on fossil fuels means more pollution. Only a transition to electric vehicles and investment in EV infrastructure will put us on the road to a 100% clean transportation sector in North Carolina.

Sincerely,

Donna Durfee
2100 Collingdale Place
Charlotte, NC 28210
dddurfee@msn.com
(704) 553-7321

This message was sent by KnowWho, as a service provider only, on behalf of the individual noted in the sender information.

From: Chelsea Barnes (chelsearuth@gmail.com) Sent You a Personal Message
To: [daq.NC_VWGrants](#)
Subject: [External] Use Volkswagen funds to electrify NC transportation
Date: Wednesday, December 06, 2017 8:27:54 AM

CAUTION: External email. Do not click links or open attachments unless verified. Send all suspicious email as an attachment to report.spam@nc.gov.

Dear Division of Air Quality,

I am writing to urge DEQ to wisely invest the \$92 million in Volkswagen settlement funds in electric vehicles and infrastructure. Taking advantage of these funds to jumpstart the electrification of North Carolina's transportation sector will mean less money sent out of state for petroleum, more in-state jobs, and cleaner air.

Specifically, I recommend that DEQ allocate the maximum allowable amount (15%) of the funds for electric vehicle charging infrastructure and installations. And I encourage DEQ to prioritize electric vehicles and buses for replacement whenever possible with the other 85% of the settlement funds. Doing so will maximize the local economic impact and the reduction of air pollution.

I encourage you to not use the funding for natural gas, propane or diesel vehicles. Further dependence on fossil fuels means more pollution. Only a transition to electric vehicles and investment in EV infrastructure will put us on the road to a 100% clean transportation sector in North Carolina.

Sincerely,

Chelsea Barnes
2505 Tryon Pines Drive
Raleigh, NC 27603
chelsearuth@gmail.com
(614) 205-6424

This message was sent by KnowWho, as a service provider only, on behalf of the individual noted in the sender information.

From: Jane Laping (janelaping@sbcglobal.net) Sent You a Personal Message
To: [daq.NC_VWGrants](#)
Subject: [External] Use Volkswagen funds to electrify NC transportation
Date: Wednesday, December 06, 2017 8:26:33 AM

CAUTION: External email. Do not click links or open attachments unless verified. Send all suspicious email as an attachment to report.spam@nc.gov.

Dear Division of Air Quality,

I am writing to urge DEQ to wisely invest the \$92 million in Volkswagen settlement funds in electric vehicles and infrastructure. Taking advantage of these funds to jumpstart the electrification of North Carolina's transportation sector will mean less money sent out of state for petroleum, more in-state jobs, and cleaner air.

Specifically, I recommend that DEQ allocate the maximum allowable amount (15%) of the funds for electric vehicle charging infrastructure and installations. And I encourage DEQ to prioritize electric vehicles and buses for replacement whenever possible with the other 85% of the settlement funds. Doing so will maximize the local economic impact and the reduction of air pollution.

I encourage you to not use the funding for natural gas, propane or diesel vehicles. Further dependence on fossil fuels means more pollution. Only a transition to electric vehicles and investment in EV infrastructure will put us on the road to a 100% clean transportation sector in North Carolina.

Sincerely,

Jane Laping
14 Concord Place
Asheville, NC 28803
janelaping@sbcglobal.net
(828) 277-7342

This message was sent by KnowWho, as a service provider only, on behalf of the individual noted in the sender information.

From: Ann Prince (irisgentian@gmail.com) Sent You a Personal Message
To: [daq.NC_VWGrants](#)
Subject: [External] Use Volkswagen funds to electrify NC transportation
Date: Wednesday, December 06, 2017 8:21:34 AM

CAUTION: External email. Do not click links or open attachments unless verified. Send all suspicious email as an attachment to report.spam@nc.gov.

Dear Division of Air Quality,

I am writing to urge DEQ to wisely invest the \$92 million in Volkswagen settlement funds in electric vehicles and infrastructure. Taking advantage of these funds to jumpstart the electrification of North Carolina's transportation sector will mean less money sent out of state for petroleum, more in-state jobs, and cleaner air.

Specifically, I recommend that DEQ allocate the maximum allowable amount (15%) of the funds for electric vehicle charging infrastructure and installations. And I encourage DEQ to prioritize electric vehicles and buses for replacement whenever possible with the other 85% of the settlement funds. Doing so will maximize the local economic impact and the reduction of air pollution.

I encourage you to not use the funding for natural gas, propane or diesel vehicles. Further dependence on fossil fuels means more pollution. Only a transition to electric vehicles and investment in EV infrastructure will put us on the road to a 100% clean transportation sector in North Carolina.

Sincerely,

Ann Prince
9808 Leslie Drive
Chapel Hill, NC 27516
irisgentian@gmail.com
(919) 929-4207

This message was sent by KnowWho, as a service provider only, on behalf of the individual noted in the sender information.

From: Ryland Bowman (ryland.g.bowman@gmail.com) Sent You a Personal Message
To: [daq.NC_VWGrants](#)
Subject: [External] Use Volkswagen funds to electrify NC transportation
Date: Wednesday, December 06, 2017 8:19:57 AM

CAUTION: External email. Do not click links or open attachments unless verified. Send all suspicious email as an attachment to report.spam@nc.gov.

Dear Division of Air Quality,

I am writing to urge DEQ to wisely invest the \$92 million in Volkswagen settlement funds in electric vehicles and infrastructure. Taking advantage of these funds to jumpstart the electrification of North Carolina's transportation sector will mean less money sent out of state for petroleum, more in-state jobs, and cleaner air.

Specifically, I recommend that DEQ allocate the maximum allowable amount (15%) of the funds for electric vehicle charging infrastructure and installations. And I encourage DEQ to prioritize electric vehicles and buses for replacement whenever possible with the other 85% of the settlement funds. Doing so will maximize the local economic impact and the reduction of air pollution.

I encourage you to not use the funding for natural gas, propane or diesel vehicles. Further dependence on fossil fuels means more pollution. Only a transition to electric vehicles and investment in EV infrastructure will put us on the road to a 100% clean transportation sector in North Carolina.

Sincerely,

Ryland Bowman
1310 Hill St.
Durham, NC 27707
ryland.g.bowman@gmail.com
(336) 549-8021

This message was sent by KnowWho, as a service provider only, on behalf of the individual noted in the sender information.

From: Melvin Hoot (hootlois@yahoo.com) Sent You a Personal Message
To: [daq.NC_VWGrants](#)
Subject: [External] Use Volkswagen funds to electrify NC transportation
Date: Wednesday, December 06, 2017 8:18:40 AM

CAUTION: External email. Do not click links or open attachments unless verified. Send all suspicious email as an attachment to report.spam@nc.gov.

Dear Division of Air Quality,

I am writing to urge DEQ to wisely invest the \$92 million in Volkswagen settlement funds in electric vehicles and infrastructure. Taking advantage of these funds to jumpstart the electrification of North Carolina's transportation sector will mean less money sent out of state for petroleum, more in-state jobs, and cleaner air.

Specifically, I recommend that DEQ allocate the maximum allowable amount (15%) of the funds for electric vehicle charging infrastructure and installations. And I encourage DEQ to prioritize electric vehicles and buses for replacement whenever possible with the other 85% of the settlement funds. Doing so will maximize the local economic impact and the reduction of air pollution.

I encourage you to not use the funding for natural gas, propane or diesel vehicles. Further dependence on fossil fuels means more pollution. Only a transition to electric vehicles and investment in EV infrastructure will put us on the road to a 100% clean transportation sector in North Carolina.

Sincerely,

Melvin Hoot
405 Alderson
Washington, NC 27889
hootlois@yahoo.com
(252) 975-5951

This message was sent by KnowWho, as a service provider only, on behalf of the individual noted in the sender information.

From: Diane Willis (dmwillis55@gmail.com) Sent You a Personal Message
To: [daq.NC_VWGrants](#)
Subject: [External] Use Volkswagen funds to electrify NC transportation
Date: Wednesday, December 06, 2017 8:09:37 AM

CAUTION: External email. Do not click links or open attachments unless verified. Send all suspicious email as an attachment to report.spam@nc.gov.

Dear Division of Air Quality,

I am writing to urge DEQ to wisely invest the \$92 million in Volkswagen settlement funds in electric vehicles and infrastructure. Taking advantage of these funds to jumpstart the electrification of North Carolina's transportation sector will mean less money sent out of state for petroleum, more in-state jobs, and cleaner air.

Specifically, I recommend that DEQ allocate the maximum allowable amount (15%) of the funds for electric vehicle charging infrastructure and installations. And I encourage DEQ to prioritize electric vehicles and buses for replacement whenever possible with the other 85% of the settlement funds. Doing so will maximize the local economic impact and the reduction of air pollution.

I encourage you to not use the funding for natural gas, propane or diesel vehicles. Further dependence on fossil fuels means more pollution. Only a transition to electric vehicles and investment in EV infrastructure will put us on the road to a 100% clean transportation sector in North Carolina.

Sincerely,

Diane Willis
11732, Silverado Lane
Charlotte, NC 28277
dmwillis55@gmail.com
(704) 553-0690

This message was sent by KnowWho, as a service provider only, on behalf of the individual noted in the sender information.

From: Bob Pendergrass (bob.pendergrass@rowancountync.gov) Sent You a Personal Message
To: [daq.NC_VWGrants](#)
Subject: [External] Use Volkswagen funds to electrify NC transportation
Date: Wednesday, December 06, 2017 7:59:52 AM

CAUTION: External email. Do not click links or open attachments unless verified. Send all suspicious email as an attachment to report.spam@nc.gov.

Dear Division of Air Quality,

I am writing to urge DEQ to wisely invest the \$92 million in Volkswagen settlement funds in electric vehicles and infrastructure. Taking advantage of these funds to jumpstart the electrification of North Carolina's transportation sector will mean less money sent out of state for petroleum, more in-state jobs, and cleaner air.

Specifically, I recommend that DEQ allocate the maximum allowable amount (15%) of the funds for electric vehicle charging infrastructure and installations. And I encourage DEQ to prioritize electric vehicles and buses for replacement whenever possible with the other 85% of the settlement funds. Doing so will maximize the local economic impact and the reduction of air pollution.

I encourage you to not use the funding for natural gas, propane or diesel vehicles. Further dependence on fossil fuels means more pollution. Only a transition to electric vehicles and investment in EV infrastructure will put us on the road to a 100% clean transportation sector in North Carolina.

Sincerely,

Bob Pendergrass
1100 Rowan Mills Rd
Salisbury, NC 28147
bob.pendergrass@rowancountync.gov
(704) 326-2641

This message was sent by KnowWho, as a service provider only, on behalf of the individual noted in the sender information.

From: Cliff Lowery (lowerycc@aol.com) Sent You a Personal Message
To: [daq.NC_VWGrants](#)
Subject: [External] Use Volkswagen funds to electrify NC transportation
Date: Wednesday, December 06, 2017 7:52:46 AM

CAUTION: External email. Do not click links or open attachments unless verified. Send all suspicious email as an attachment to report.spam@nc.gov.

Dear Division of Air Quality,

I am writing to urge DEQ to wisely invest the \$92 million in Volkswagen settlement funds in electric vehicles and infrastructure. Taking advantage of these funds to jumpstart the electrification of North Carolina's transportation sector will mean less money sent out of state for petroleum, more in-state jobs, and cleaner air.

Specifically, I recommend that DEQ allocate the maximum allowable amount (15%) of the funds for electric vehicle charging infrastructure and installations. And I encourage DEQ to prioritize electric vehicles and buses for replacement whenever possible with the other 85% of the settlement funds. Doing so will maximize the local economic impact and the reduction of air pollution.

I encourage you to not use the funding for natural gas, propane or diesel vehicles. Further dependence on fossil fuels means more pollution. Only a transition to electric vehicles and investment in EV infrastructure will put us on the road to a 100% clean transportation sector in North Carolina.

Sincerely,

Cliff Lowery
615 Whitsett Avenue
Gibsonville, NC 27249
lowerycc@aol.com
(336) 210-6923

This message was sent by KnowWho, as a service provider only, on behalf of the individual noted in the sender information.

From: Russell Fowler (rfowler30@yahoo.com) Sent You a Personal Message
To: [daq.NC_VWGrants](#)
Subject: [External] Use Volkswagen funds to electrify NC transportation
Date: Wednesday, December 06, 2017 7:51:43 AM

CAUTION: External email. Do not click links or open attachments unless verified. Send all suspicious email as an attachment to report.spam@nc.gov.

Dear Division of Air Quality,

I am writing to urge DEQ to wisely invest the \$92 million in Volkswagen settlement funds in electric vehicles and infrastructure. Taking advantage of these funds to jumpstart the electrification of North Carolina's transportation sector will mean less money sent out of state for petroleum, more in-state jobs, and cleaner air.

Specifically, I recommend that DEQ allocate the maximum allowable amount (15%) of the funds for electric vehicle charging infrastructure and installations. And I encourage DEQ to prioritize electric vehicles and buses for replacement whenever possible with the other 85% of the settlement funds. Doing so will maximize the local economic impact and the reduction of air pollution.

I encourage you to not use the funding for natural gas, propane or diesel vehicles. Further dependence on fossil fuels means more pollution. Only a transition to electric vehicles and investment in EV infrastructure will put us on the road to a 100% clean transportation sector in North Carolina.

Sincerely,

Russell Fowler
520 Harvest Place
Swansboro, NC 28584
rfowler30@yahoo.com
(910) 326-7413

This message was sent by KnowWho, as a service provider only, on behalf of the individual noted in the sender information.

From: Hedi Perotto (hedi.perotto@gmail.com) Sent You a Personal Message
To: [daq.NC_VWGrants](#)
Subject: [External] Use Volkswagen funds to electrify NC transportation
Date: Wednesday, December 06, 2017 7:50:36 AM

CAUTION: External email. Do not click links or open attachments unless verified. Send all suspicious email as an attachment to report.spam@nc.gov.

Dear Division of Air Quality,

I am writing to urge DEQ to wisely invest the \$92 million in Volkswagen settlement funds in electric vehicles and infrastructure. Taking advantage of these funds to jumpstart the electrification of North Carolina's transportation sector will mean less money sent out of state for petroleum, more in-state jobs, and cleaner air.

Specifically, I recommend that DEQ allocate the maximum allowable amount (15%) of the funds for electric vehicle charging infrastructure and installations. And I encourage DEQ to prioritize electric vehicles and buses for replacement whenever possible with the other 85% of the settlement funds. Doing so will maximize the local economic impact and the reduction of air pollution.

I encourage you to not use the funding for natural gas, propane or diesel vehicles. Further dependence on fossil fuels means more pollution. Only a transition to electric vehicles and investment in EV infrastructure will put us on the road to a 100% clean transportation sector in North Carolina.

Sincerely,

Hedi Perotto
2105 East Lake Shore Drive
Wilmington, NC 28401
hedi.perotto@gmail.com
(910) 859-8383

This message was sent by KnowWho, as a service provider only, on behalf of the individual noted in the sender information.

From: Andrew Race (rewdyrace@gmail.com) Sent You a Personal Message
To: daq.NC_VWGrants
Subject: [External] Use Volkswagen funds to electrify NC transportation
Date: Wednesday, December 06, 2017 7:45:26 AM

CAUTION: External email. Do not click links or open attachments unless verified. Send all suspicious email as an attachment to report.spam@nc.gov.

Dear Division of Air Quality,

I am writing to urge DEQ to wisely invest the \$92 million in Volkswagen settlement funds in electric vehicles and infrastructure. Taking advantage of these funds to jumpstart the electrification of North Carolina's transportation sector will mean less money sent out of state for petroleum, more in-state jobs, and cleaner air.

Specifically, I recommend that DEQ allocate the maximum allowable amount (15%) of the funds for electric vehicle charging infrastructure and installations. And I encourage DEQ to prioritize electric vehicles and buses for replacement whenever possible with the other 85% of the settlement funds. Doing so will maximize the local economic impact and the reduction of air pollution.

I encourage you to not use the funding for natural gas, propane or diesel vehicles. Further dependence on fossil fuels means more pollution. Only a transition to electric vehicles and investment in EV infrastructure will put us on the road to a 100% clean transportation sector in North Carolina.

Sincerely,

Andrew Race
5260 Wilson Hill Ct
Winston Salem, NC 27104
rewdyrace@gmail.com
(773) 342-1141

This message was sent by KnowWho, as a service provider only, on behalf of the individual noted in the sender information.

From: Patricia Queen (patqueen2003@gmail.com) Sent You a Personal Message
To: [daq.NC_VWGrants](#)
Subject: [External] Use Volkswagen funds to electrify NC transportation
Date: Wednesday, December 06, 2017 7:45:00 AM

CAUTION: External email. Do not click links or open attachments unless verified. Send all suspicious email as an attachment to report.spam@nc.gov.

Dear Division of Air Quality,

I am writing to urge DEQ to wisely invest the \$92 million in Volkswagen settlement funds in electric vehicles and infrastructure. Taking advantage of these funds to jumpstart the electrification of North Carolina's transportation sector will mean less money sent out of state for petroleum, more in-state jobs, and cleaner air.

Specifically, I recommend that DEQ allocate the maximum allowable amount (15%) of the funds for electric vehicle charging infrastructure and installations. And I encourage DEQ to prioritize electric vehicles and buses for replacement whenever possible with the other 85% of the settlement funds. Doing so will maximize the local economic impact and the reduction of air pollution.

I encourage you to not use the funding for natural gas, propane or diesel vehicles. Further dependence on fossil fuels means more pollution. Only a transition to electric vehicles and investment in EV infrastructure will put us on the road to a 100% clean transportation sector in North Carolina.

Sincerely,

Patricia Queen
848 West Stallings St
Clayton, NC 27520
patqueen2003@gmail.com
(919) 413-1333

This message was sent by KnowWho, as a service provider only, on behalf of the individual noted in the sender information.

From: Christy McFadden (autygila@gmail.com) Sent You a Personal Message
To: [daq.NC_VWGrants](#)
Subject: [External] Use Volkswagen funds to electrify NC transportation
Date: Wednesday, December 06, 2017 7:41:06 AM

CAUTION: External email. Do not click links or open attachments unless verified. Send all suspicious email as an attachment to report.spam@nc.gov.

Dear Division of Air Quality,

I am writing to urge DEQ to wisely invest the \$92 million in Volkswagen settlement funds in electric vehicles and infrastructure. Taking advantage of these funds to jumpstart the electrification of North Carolina's transportation sector will mean less money sent out of state for petroleum, more in-state jobs, and cleaner air.

Specifically, I recommend that DEQ allocate the maximum allowable amount (15%) of the funds for electric vehicle charging infrastructure and installations. And I encourage DEQ to prioritize electric vehicles and buses for replacement whenever possible with the other 85% of the settlement funds. Doing so will maximize the local economic impact and the reduction of air pollution.

I encourage you to not use the funding for natural gas, propane or diesel vehicles. Further dependence on fossil fuels means more pollution. Only a transition to electric vehicles and investment in EV infrastructure will put us on the road to a 100% clean transportation sector in North Carolina.

Sincerely,

Christy McFadden
21 Alex Drive
Asheville, NC 28805
autygila@gmail.com
(828) 215-7634

This message was sent by KnowWho, as a service provider only, on behalf of the individual noted in the sender information.

From: John Dunning (johnjdunning@gmail.com) Sent You a Personal Message
To: [daq.NC_VWGrants](#)
Subject: [External] Use Volkswagen funds to electrify NC transportation
Date: Wednesday, December 06, 2017 7:38:22 AM

CAUTION: External email. Do not click links or open attachments unless verified. Send all suspicious email as an attachment to report.spam@nc.gov.

Dear Division of Air Quality,

I am writing to urge DEQ to wisely invest the \$92 million in Volkswagen settlement funds in electric vehicles and infrastructure. Taking advantage of these funds to jumpstart the electrification of North Carolina's transportation sector will mean less money sent out of state for petroleum, more in-state jobs, and cleaner air.

Specifically, I recommend that DEQ allocate the maximum allowable amount (15%) of the funds for electric vehicle charging infrastructure and installations. And I encourage DEQ to prioritize electric vehicles and buses for replacement whenever possible with the other 85% of the settlement funds. Doing so will maximize the local economic impact and the reduction of air pollution.

I encourage you to not use the funding for natural gas, propane or diesel vehicles. Further dependence on fossil fuels means more pollution. Only a transition to electric vehicles and investment in EV infrastructure will put us on the road to a 100% clean transportation sector in North Carolina.

Sincerely,

John Dunning
950 Spring Forest Road, Apt 2H
Greenville, NC 27834
johnjdunning@gmail.com
(814) 330-3704

This message was sent by KnowWho, as a service provider only, on behalf of the individual noted in the sender information.

From: Jade Dell (jade.dell45@gmail.com) Sent You a Personal Message
To: [daq.NC_VWGrants](#)
Subject: [External] Use Volkswagen funds to electrify NC transportation
Date: Wednesday, December 06, 2017 7:17:11 AM

CAUTION: External email. Do not click links or open attachments unless verified. Send all suspicious email as an attachment to report.spam@nc.gov.

Dear Division of Air Quality,

I am writing to urge DEQ to wisely invest the \$92 million in Volkswagen settlement funds in electric vehicles and infrastructure. Taking advantage of these funds to jumpstart the electrification of North Carolina's transportation sector will mean less money sent out of state for petroleum, more in-state jobs, and cleaner air.

Specifically, I recommend that DEQ allocate the maximum allowable amount (15%) of the funds for electric vehicle charging infrastructure and installations. And I encourage DEQ to prioritize electric vehicles and buses for replacement whenever possible with the other 85% of the settlement funds. Doing so will maximize the local economic impact and the reduction of air pollution.

I encourage you to not use the funding for natural gas, propane or diesel vehicles. Further dependence on fossil fuels means more pollution. Only a transition to electric vehicles and investment in EV infrastructure will put us on the road to a 100% clean transportation sector in North Carolina.

Sincerely,

Jade Dell
927 West Morgan Street, Apt. 159
Raleigh, NC 27603
jade.dell45@gmail.com
(773) 750-0125

This message was sent by KnowWho, as a service provider only, on behalf of the individual noted in the sender information.

From: Virgil Carmichael (virgilcarmichael@gmail.com) Sent You a Personal Message
To: [daq.NC_VWGrants](#)
Subject: [External] Use Volkswagen funds to electrify NC transportation
Date: Wednesday, December 06, 2017 7:15:32 AM

CAUTION: External email. Do not click links or open attachments unless verified. Send all suspicious email as an attachment to report.spam@nc.gov.

Dear Division of Air Quality,

I am writing to urge DEQ to wisely invest the \$92 million in Volkswagen settlement funds in electric vehicles and infrastructure. Taking advantage of these funds to jumpstart the electrification of North Carolina's transportation sector will mean less money sent out of state for petroleum, more in-state jobs, and cleaner air.

Specifically, I recommend that DEQ allocate the maximum allowable amount (15%) of the funds for electric vehicle charging infrastructure and installations. And I encourage DEQ to prioritize electric vehicles and buses for replacement whenever possible with the other 85% of the settlement funds. Doing so will maximize the local economic impact and the reduction of air pollution.

I encourage you to not use the funding for natural gas, propane or diesel vehicles. Further dependence on fossil fuels means more pollution. Only a transition to electric vehicles and investment in EV infrastructure will put us on the road to a 100% clean transportation sector in North Carolina.

Sincerely,

Virgil Carmichael
4403 Angelus Circle
Asheville, NC 28805
virgilcarmichael@gmail.com
(828) 242-7709

This message was sent by KnowWho, as a service provider only, on behalf of the individual noted in the sender information.

From: Robert Becquet (r.becquet@windstream.net) Sent You a Personal Message
To: daq.NC_VWGrants
Subject: [External] Use Volkswagen funds to electrify NC transportation
Date: Wednesday, December 06, 2017 7:14:31 AM

CAUTION: External email. Do not click links or open attachments unless verified. Send all suspicious email as an attachment to report.spam@nc.gov.

Dear Division of Air Quality,

I am writing to urge DEQ to wisely invest the \$92 million in Volkswagen settlement funds in electric vehicles and infrastructure. Taking advantage of these funds to jumpstart the electrification of North Carolina's transportation sector will mean less money sent out of state for petroleum, more in-state jobs, and cleaner air.

Specifically, I recommend that DEQ allocate the maximum allowable amount (15%) of the funds for electric vehicle charging infrastructure and installations. And I encourage DEQ to prioritize electric vehicles and buses for replacement whenever possible with the other 85% of the settlement funds. Doing so will maximize the local economic impact and the reduction of air pollution.

I encourage you to not use the funding for natural gas, propane or diesel vehicles. Further dependence on fossil fuels means more pollution. Only a transition to electric vehicles and investment in EV infrastructure will put us on the road to a 100% clean transportation sector in North Carolina.

Sincerely,

Robert Becquet
12599 NC 27 W
Broadway, NC 27505
r.becquet@windstream.net
(919) 499-2344

This message was sent by KnowWho, as a service provider only, on behalf of the individual noted in the sender information.

From: Vivian Ratliff (vivrd@hotmail.com) Sent You a Personal Message
To: [daq.NC_VWGrants](#)
Subject: [External] Use Volkswagen funds to electrify NC transportation
Date: Wednesday, December 06, 2017 7:08:57 AM

CAUTION: External email. Do not click links or open attachments unless verified. Send all suspicious email as an attachment to report.spam@nc.gov.

Dear Division of Air Quality,

I am writing to urge DEQ to wisely invest the \$92 million in Volkswagen settlement funds in electric vehicles and infrastructure. Taking advantage of these funds to jumpstart the electrification of North Carolina's transportation sector will mean less money sent out of state for petroleum, more in-state jobs, and cleaner air.

Specifically, I recommend that DEQ allocate the maximum allowable amount (15%) of the funds for electric vehicle charging infrastructure and installations. And I encourage DEQ to prioritize electric vehicles and buses for replacement whenever possible with the other 85% of the settlement funds. Doing so will maximize the local economic impact and the reduction of air pollution.

I encourage you to not use the funding for natural gas, propane or diesel vehicles. Further dependence on fossil fuels means more pollution. Only a transition to electric vehicles and investment in EV infrastructure will put us on the road to a 100% clean transportation sector in North Carolina.

Sincerely,

Vivian Ratliff
30 Briarwood Circle
Pinehurst, NC 28374
vivrd@hotmail.com
(910) 638-8336

This message was sent by KnowWho, as a service provider only, on behalf of the individual noted in the sender information.

From: Darlene Hamilton (darlene.hamilton@siemems.com) Sent You a Personal Message
To: [daq.NC_VWGrants](#)
Subject: [External] Use Volkswagen funds to electrify NC transportation
Date: Wednesday, December 06, 2017 7:08:36 AM

CAUTION: External email. Do not click links or open attachments unless verified. Send all suspicious email as an attachment to report.spam@nc.gov.

Dear Division of Air Quality,

I am writing to urge DEQ to wisely invest the \$92 million in Volkswagen settlement funds in electric vehicles and infrastructure. Taking advantage of these funds to jumpstart the electrification of North Carolina's transportation sector will mean less money sent out of state for petroleum, more in-state jobs, and cleaner air.

Specifically, I recommend that DEQ allocate the maximum allowable amount (15%) of the funds for electric vehicle charging infrastructure and installations. And I encourage DEQ to prioritize electric vehicles and buses for replacement whenever possible with the other 85% of the settlement funds. Doing so will maximize the local economic impact and the reduction of air pollution.

I encourage you to not use the funding for natural gas, propane or diesel vehicles. Further dependence on fossil fuels means more pollution. Only a transition to electric vehicles and investment in EV infrastructure will put us on the road to a 100% clean transportation sector in North Carolina.

Sincerely,

Darlene Hamilton
1605 Beacon Valley Dr
Raleigh, NC 27604
darlene.hamilton@siemems.com
(919) 463-1942

This message was sent by KnowWho, as a service provider only, on behalf of the individual noted in the sender information.

From: Amanda Bahr (silliana2007@gmail.com) Sent You a Personal Message
To: [daq.NC_VWGrants](#)
Subject: [External] Use Volkswagen funds to electrify NC transportation
Date: Wednesday, December 06, 2017 7:06:49 AM

CAUTION: External email. Do not click links or open attachments unless verified. Send all suspicious email as an attachment to report.spam@nc.gov.

Dear Division of Air Quality,

I am writing to urge DEQ to wisely invest the \$92 million in Volkswagen settlement funds in electric vehicles and infrastructure. Taking advantage of these funds to jumpstart the electrification of North Carolina's transportation sector will mean less money sent out of state for petroleum, more in-state jobs, and cleaner air.

Specifically, I recommend that DEQ allocate the maximum allowable amount (15%) of the funds for electric vehicle charging infrastructure and installations. And I encourage DEQ to prioritize electric vehicles and buses for replacement whenever possible with the other 85% of the settlement funds. Doing so will maximize the local economic impact and the reduction of air pollution.

I encourage you to not use the funding for natural gas, propane or diesel vehicles. Further dependence on fossil fuels means more pollution. Only a transition to electric vehicles and investment in EV infrastructure will put us on the road to a 100% clean transportation sector in North Carolina.

Sincerely,

Amanda Bahr
P o box 254
Carolina Beach, NC 28428
silliana2007@gmail.com
(910) 431-8152

This message was sent by KnowWho, as a service provider only, on behalf of the individual noted in the sender information.

From: Mary Tuma (nat13421@gmail.com) Sent You a Personal Message
To: [daq.NC_VWGrants](#)
Subject: [External] Use Volkswagen funds to electrify NC transportation
Date: Wednesday, December 06, 2017 7:05:31 AM

CAUTION: External email. Do not click links or open attachments unless verified. Send all suspicious email as an attachment to report.spam@nc.gov.

Dear Division of Air Quality,

I am writing to urge DEQ to wisely invest the \$92 million in Volkswagen settlement funds in electric vehicles and infrastructure. Taking advantage of these funds to jumpstart the electrification of North Carolina's transportation sector will mean less money sent out of state for petroleum, more in-state jobs, and cleaner air.

Specifically, I recommend that DEQ allocate the maximum allowable amount (15%) of the funds for electric vehicle charging infrastructure and installations. And I encourage DEQ to prioritize electric vehicles and buses for replacement whenever possible with the other 85% of the settlement funds. Doing so will maximize the local economic impact and the reduction of air pollution.

I encourage you to not use the funding for natural gas, propane or diesel vehicles. Further dependence on fossil fuels means more pollution. Only a transition to electric vehicles and investment in EV infrastructure will put us on the road to a 100% clean transportation sector in North Carolina.

Sincerely,

Mary Tuma
4020 Larkspur Lane
Charlotte, NC 28205
nat13421@gmail.com
(980) 333-7545

This message was sent by KnowWho, as a service provider only, on behalf of the individual noted in the sender information.

From: Paul Kiely (teacherkiely@gmail.com) Sent You a Personal Message
To: [daq.NC_VWGrants](#)
Subject: [External] Use Volkswagen funds to electrify NC transportation
Date: Wednesday, December 06, 2017 6:58:02 AM

CAUTION: External email. Do not click links or open attachments unless verified. Send all suspicious email as an attachment to report.spam@nc.gov.

Dear Division of Air Quality,

I am writing to urge DEQ to wisely invest the \$92 million in Volkswagen settlement funds in electric vehicles and infrastructure. Taking advantage of these funds to jumpstart the electrification of North Carolina's transportation sector will mean less money sent out of state for petroleum, more in-state jobs, and cleaner air.

Specifically, I recommend that DEQ allocate the maximum allowable amount (15%) of the funds for electric vehicle charging infrastructure and installations. And I encourage DEQ to prioritize electric vehicles and buses for replacement whenever possible with the other 85% of the settlement funds. Doing so will maximize the local economic impact and the reduction of air pollution.

I encourage you to not use the funding for natural gas, propane or diesel vehicles. Further dependence on fossil fuels means more pollution. Only a transition to electric vehicles and investment in EV infrastructure will put us on the road to a 100% clean transportation sector in North Carolina.

Sincerely,

Paul Kiely
1023 Laurel Valley Drive
New Bern, NC 28562
teacherkiely@gmail.com
(603) 528-3602

This message was sent by KnowWho, as a service provider only, on behalf of the individual noted in the sender information.

From: Stephanie Adams (sadams9008@att.net) Sent You a Personal Message
To: [daq.NC_VWGrants](#)
Subject: [External] Use Volkswagen funds to electrify NC transportation
Date: Wednesday, December 06, 2017 6:58:00 AM

CAUTION: External email. Do not click links or open attachments unless verified. Send all suspicious email as an attachment to report.spam@nc.gov.

Dear Division of Air Quality,

I am writing to urge DEQ to wisely invest the \$92 million in Volkswagen settlement funds in electric vehicles and infrastructure. Taking advantage of these funds to jumpstart the electrification of North Carolina's transportation sector will mean less money sent out of state for petroleum, more in-state jobs, and cleaner air.

Specifically, I recommend that DEQ allocate the maximum allowable amount (15%) of the funds for electric vehicle charging infrastructure and installations. And I encourage DEQ to prioritize electric vehicles and buses for replacement whenever possible with the other 85% of the settlement funds. Doing so will maximize the local economic impact and the reduction of air pollution.

I encourage you to not use the funding for natural gas, propane or diesel vehicles. Further dependence on fossil fuels means more pollution. Only a transition to electric vehicles and investment in EV infrastructure will put us on the road to a 100% clean transportation sector in North Carolina.

Sincerely,

Stephanie Adams
3430 Prince George Ave., None
Castle Hayne, NC 28429
sadams9008@att.net
(910) 675-2054

This message was sent by KnowWho, as a service provider only, on behalf of the individual noted in the sender information.

From: Kim Fuelling (kimfuelling@gmail.com) Sent You a Personal Message
To: [daq.NC_VWGrants](#)
Subject: [External] Use Volkswagen funds to electrify NC transportation
Date: Wednesday, December 06, 2017 6:52:58 AM

CAUTION: External email. Do not click links or open attachments unless verified. Send all suspicious email as an attachment to report.spam@nc.gov.

Dear Division of Air Quality,

I am writing to urge DEQ to wisely invest the \$92 million in Volkswagen settlement funds in electric vehicles and infrastructure. Taking advantage of these funds to jumpstart the electrification of North Carolina's transportation sector will mean less money sent out of state for petroleum, more in-state jobs, and cleaner air.

Specifically, I recommend that DEQ allocate the maximum allowable amount (15%) of the funds for electric vehicle charging infrastructure and installations. And I encourage DEQ to prioritize electric vehicles and buses for replacement whenever possible with the other 85% of the settlement funds. Doing so will maximize the local economic impact and the reduction of air pollution.

I encourage you to not use the funding for natural gas, propane or diesel vehicles. Further dependence on fossil fuels means more pollution. Only a transition to electric vehicles and investment in EV infrastructure will put us on the road to a 100% clean transportation sector in North Carolina.

Sincerely,

Kim Fuelling
285 Grover Norris Rd
Zionville, NC 28698
kimfuelling@gmail.com
(828) 297-1972

This message was sent by KnowWho, as a service provider only, on behalf of the individual noted in the sender information.

From: Lidia Lucaciu (llucaciu12@gmail.com) Sent You a Personal Message
To: [daq.NC_VWGrants](#)
Subject: [External] Use Volkswagen funds to electrify NC transportation
Date: Wednesday, December 06, 2017 6:49:49 AM

CAUTION: External email. Do not click links or open attachments unless verified. Send all suspicious email as an attachment to report.spam@nc.gov.

Dear Division of Air Quality,

I am writing to urge DEQ to wisely invest the \$92 million in Volkswagen settlement funds in electric vehicles and infrastructure. Taking advantage of these funds to jumpstart the electrification of North Carolina's transportation sector will mean less money sent out of state for petroleum, more in-state jobs, and cleaner air.

Specifically, I recommend that DEQ allocate the maximum allowable amount (15%) of the funds for electric vehicle charging infrastructure and installations. And I encourage DEQ to prioritize electric vehicles and buses for replacement whenever possible with the other 85% of the settlement funds. Doing so will maximize the local economic impact and the reduction of air pollution.

I encourage you to not use the funding for natural gas, propane or diesel vehicles. Further dependence on fossil fuels means more pollution. Only a transition to electric vehicles and investment in EV infrastructure will put us on the road to a 100% clean transportation sector in North Carolina.

Sincerely,

Lidia Lucaciu
2446 27th Avenue Circle NE
Hickory, NC 28601
llucaciu12@gmail.com
(828) 256-7903

This message was sent by KnowWho, as a service provider only, on behalf of the individual noted in the sender information.

From: Laura Ghantous (lghantous@mac.com) Sent You a Personal Message
To: [daq.NC_VWGrants](#)
Subject: [External] Use Volkswagen funds to electrify NC transportation
Date: Wednesday, December 06, 2017 6:49:49 AM

CAUTION: External email. Do not click links or open attachments unless verified. Send all suspicious email as an attachment to report.spam@nc.gov.

Dear Division of Air Quality,

I am writing to urge DEQ to wisely invest the \$92 million in Volkswagen settlement funds in electric vehicles and infrastructure. Taking advantage of these funds to jumpstart the electrification of North Carolina's transportation sector will mean less money sent out of state for petroleum, more in-state jobs, and cleaner air.

Specifically, I recommend that DEQ allocate the maximum allowable amount (15%) of the funds for electric vehicle charging infrastructure and installations. And I encourage DEQ to prioritize electric vehicles and buses for replacement whenever possible with the other 85% of the settlement funds. Doing so will maximize the local economic impact and the reduction of air pollution.

I encourage you to not use the funding for natural gas, propane or diesel vehicles. Further dependence on fossil fuels means more pollution. Only a transition to electric vehicles and investment in EV infrastructure will put us on the road to a 100% clean transportation sector in North Carolina.

Sincerely,

Laura Ghantous
822 Cotton Place
Laura, NC 27601
lghantous@mac.com
(919) 862-0878

This message was sent by KnowWho, as a service provider only, on behalf of the individual noted in the sender information.

From: Denise Brown (denisebrown@hotmail.com) Sent You a Personal Message
To: [daq.NC_VWGrants](#)
Subject: [External] Use Volkswagen funds to electrify NC transportation
Date: Wednesday, December 06, 2017 6:46:58 AM

CAUTION: External email. Do not click links or open attachments unless verified. Send all suspicious email as an attachment to report.spam@nc.gov.

Dear Division of Air Quality,

I am writing to urge DEQ to wisely invest the \$92 million in Volkswagen settlement funds in electric vehicles and infrastructure. Taking advantage of these funds to jumpstart the electrification of North Carolina's transportation sector will mean less money sent out of state for petroleum, more in-state jobs, and cleaner air.

Specifically, I recommend that DEQ allocate the maximum allowable amount (15%) of the funds for electric vehicle charging infrastructure and installations. And I encourage DEQ to prioritize electric vehicles and buses for replacement whenever possible with the other 85% of the settlement funds. Doing so will maximize the local economic impact and the reduction of air pollution.

I encourage you to not use the funding for natural gas, propane or diesel vehicles. Further dependence on fossil fuels means more pollution. Only a transition to electric vehicles and investment in EV infrastructure will put us on the road to a 100% clean transportation sector in North Carolina.

Sincerely,

Denise Brown
432 N Brady St
Denise, NC 27316
denisebrown@hotmail.com
(336) 302-4507

This message was sent by KnowWho, as a service provider only, on behalf of the individual noted in the sender information.

From: patricia english (penglish@wilkes.net) Sent You a Personal Message
To: [daq.NC_VWGrants](#)
Subject: [External] Use Volkswagen funds to electrify NC transportation
Date: Wednesday, December 06, 2017 6:42:17 AM

CAUTION: External email. Do not click links or open attachments unless verified. Send all suspicious email as an attachment to report.spam@nc.gov.

Dear Division of Air Quality,

I am writing to urge DEQ to wisely invest the \$92 million in Volkswagen settlement funds in electric vehicles and infrastructure. Taking advantage of these funds to jumpstart the electrification of North Carolina's transportation sector will mean less money sent out of state for petroleum, more in-state jobs, and cleaner air.

Specifically, I recommend that DEQ allocate the maximum allowable amount (15%) of the funds for electric vehicle charging infrastructure and installations. And I encourage DEQ to prioritize electric vehicles and buses for replacement whenever possible with the other 85% of the settlement funds. Doing so will maximize the local economic impact and the reduction of air pollution.

I encourage you to not use the funding for natural gas, propane or diesel vehicles. Further dependence on fossil fuels means more pollution. Only a transition to electric vehicles and investment in EV infrastructure will put us on the road to a 100% clean transportation sector in North Carolina.

Sincerely,

patricia english
313 deer creek lane
wilkesboro, NC 28697
penglish@wilkes.net
(336) 428-5339

This message was sent by KnowWho, as a service provider only, on behalf of the individual noted in the sender information.

From: alexandria williams (aswillia13@yahoo.com) Sent You a Personal Message
To: [daq.NC_VWGrants](#)
Subject: [External] Use Volkswagen funds to electrify NC transportation
Date: Wednesday, December 06, 2017 6:35:39 AM

CAUTION: External email. Do not click links or open attachments unless verified. Send all suspicious email as an attachment to report.spam@nc.gov.

Dear Division of Air Quality,

I am writing to urge DEQ to wisely invest the \$92 million in Volkswagen settlement funds in electric vehicles and infrastructure. Taking advantage of these funds to jumpstart the electrification of North Carolina's transportation sector will mean less money sent out of state for petroleum, more in-state jobs, and cleaner air.

Specifically, I recommend that DEQ allocate the maximum allowable amount (15%) of the funds for electric vehicle charging infrastructure and installations. And I encourage DEQ to prioritize electric vehicles and buses for replacement whenever possible with the other 85% of the settlement funds. Doing so will maximize the local economic impact and the reduction of air pollution.

I encourage you to not use the funding for natural gas, propane or diesel vehicles. Further dependence on fossil fuels means more pollution. Only a transition to electric vehicles and investment in EV infrastructure will put us on the road to a 100% clean transportation sector in North Carolina.

Sincerely,

alexandria williams
287 Catalina Dr
Mooreville, NC 28117
aswillia13@yahoo.com
(704) 662-2117

This message was sent by KnowWho, as a service provider only, on behalf of the individual noted in the sender information.

From: vivian barro (viviancb1@hotmail.com) Sent You a Personal Message
To: [daq.NC_VWGrants](#)
Subject: [External] Use Volkswagen funds to electrify NC transportation
Date: Wednesday, December 06, 2017 6:19:18 AM

CAUTION: External email. Do not click links or open attachments unless verified. Send all suspicious email as an attachment to report.spam@nc.gov.

Dear Division of Air Quality,

I am writing to urge DEQ to wisely invest the \$92 million in Volkswagen settlement funds in electric vehicles and infrastructure. Taking advantage of these funds to jumpstart the electrification of North Carolina's transportation sector will mean less money sent out of state for petroleum, more in-state jobs, and cleaner air.

Specifically, I recommend that DEQ allocate the maximum allowable amount (15%) of the funds for electric vehicle charging infrastructure and installations. And I encourage DEQ to prioritize electric vehicles and buses for replacement whenever possible with the other 85% of the settlement funds. Doing so will maximize the local economic impact and the reduction of air pollution.

I encourage you to not use the funding for natural gas, propane or diesel vehicles. Further dependence on fossil fuels means more pollution. Only a transition to electric vehicles and investment in EV infrastructure will put us on the road to a 100% clean transportation sector in North Carolina.

Sincerely,

vivian barro
603 w harvie ave
Gastonia, NC 28052
viviancb1@hotmail.com
(305) 962-7646

This message was sent by KnowWho, as a service provider only, on behalf of the individual noted in the sender information.

From: Jennifer Warrillow (jenwarrillow@yahoo.com) Sent You a Personal Message
To: [daq.NC_VWGrants](#)
Subject: [External] Use Volkswagen funds to electrify NC transportation
Date: Wednesday, December 06, 2017 5:52:42 AM

CAUTION: External email. Do not click links or open attachments unless verified. Send all suspicious email as an attachment to report.spam@nc.gov.

Dear Division of Air Quality,

I am writing to urge DEQ to wisely invest the \$92 million in Volkswagen settlement funds in electric vehicles and infrastructure. Taking advantage of these funds to jumpstart the electrification of North Carolina's transportation sector will mean less money sent out of state for petroleum, more in-state jobs, and cleaner air.

Specifically, I recommend that DEQ allocate the maximum allowable amount (15%) of the funds for electric vehicle charging infrastructure and installations. And I encourage DEQ to prioritize electric vehicles and buses for replacement whenever possible with the other 85% of the settlement funds. Doing so will maximize the local economic impact and the reduction of air pollution.

I encourage you to not use the funding for natural gas, propane or diesel vehicles. Further dependence on fossil fuels means more pollution. Only a transition to electric vehicles and investment in EV infrastructure will put us on the road to a 100% clean transportation sector in North Carolina.

Sincerely,

Jennifer Warrillow
5703 Three Oaks Dr
Raleigh, NC 27612
jenwarrillow@yahoo.com
(919) 324-8776

This message was sent by KnowWho, as a service provider only, on behalf of the individual noted in the sender information.

From: Chip LORD (cjlord1@gmail.com) Sent You a Personal Message
To: [daq.NC_VWGrants](#)
Subject: [External] Use Volkswagen funds to electrify NC transportation
Date: Wednesday, December 06, 2017 5:44:48 AM

CAUTION: External email. Do not click links or open attachments unless verified. Send all suspicious email as an attachment to report.spam@nc.gov.

Dear Division of Air Quality,

I am writing to urge DEQ to wisely invest the \$92 million in Volkswagen settlement funds in electric vehicles and infrastructure. Taking advantage of these funds to jumpstart the electrification of North Carolina's transportation sector will mean less money sent out of state for petroleum, more in-state jobs, and cleaner air.

Specifically, I recommend that DEQ allocate the maximum allowable amount (15%) of the funds for electric vehicle charging infrastructure and installations. And I encourage DEQ to prioritize electric vehicles and buses for replacement whenever possible with the other 85% of the settlement funds. Doing so will maximize the local economic impact and the reduction of air pollution.

I encourage you to not use the funding for natural gas, propane or diesel vehicles. Further dependence on fossil fuels means more pollution. Only a transition to electric vehicles and investment in EV infrastructure will put us on the road to a 100% clean transportation sector in North Carolina.

Sincerely,

Chip LORD
10137 Caldwell Forest Drive
Charlotte, NC 28213
cjlord1@gmail.com
(704) 971-7971

This message was sent by KnowWho, as a service provider only, on behalf of the individual noted in the sender information.

From: Walt Nelsen (grandpamike13@yahoo.com) Sent You a Personal Message
To: [daq.NC_VWGrants](#)
Subject: [External] Use Volkswagen funds to electrify NC transportation
Date: Wednesday, December 06, 2017 5:35:39 AM

CAUTION: External email. Do not click links or open attachments unless verified. Send all suspicious email as an attachment to report.spam@nc.gov.

Dear Division of Air Quality,

I am writing to urge DEQ to wisely invest the \$92 million in Volkswagen settlement funds in electric vehicles and infrastructure. Taking advantage of these funds to jumpstart the electrification of North Carolina's transportation sector will mean less money sent out of state for petroleum, more in-state jobs, and cleaner air.

Specifically, I recommend that DEQ allocate the maximum allowable amount (15%) of the funds for electric vehicle charging infrastructure and installations. And I encourage DEQ to prioritize electric vehicles and buses for replacement whenever possible with the other 85% of the settlement funds. Doing so will maximize the local economic impact and the reduction of air pollution.

I encourage you to not use the funding for natural gas, propane or diesel vehicles. Further dependence on fossil fuels means more pollution. Only a transition to electric vehicles and investment in EV infrastructure will put us on the road to a 100% clean transportation sector in North Carolina.

Sincerely,

Walt Nelsen
6375 soco
Maggie, NC 28751
grandpamike13@yahoo.com
(828) 926-6180

This message was sent by KnowWho, as a service provider only, on behalf of the individual noted in the sender information.

From: Aidan McDonald (mcdonaldwc@appstate.edu) Sent You a Personal Message
To: [daq.NC_VWGrants](#)
Subject: [External] Use Volkswagen funds to electrify NC transportation
Date: Wednesday, December 06, 2017 5:30:34 AM

CAUTION: External email. Do not click links or open attachments unless verified. Send all suspicious email as an attachment to report.spam@nc.gov.

Dear Division of Air Quality,

I am writing to urge DEQ to wisely invest the \$92 million in Volkswagen settlement funds in electric vehicles and infrastructure. Taking advantage of these funds to jumpstart the electrification of North Carolina's transportation sector will mean less money sent out of state for petroleum, more in-state jobs, and cleaner air.

Specifically, I recommend that DEQ allocate the maximum allowable amount (15%) of the funds for electric vehicle charging infrastructure and installations. And I encourage DEQ to prioritize electric vehicles and buses for replacement whenever possible with the other 85% of the settlement funds. Doing so will maximize the local economic impact and the reduction of air pollution.

I encourage you to not use the funding for natural gas, propane or diesel vehicles. Further dependence on fossil fuels means more pollution. Only a transition to electric vehicles and investment in EV infrastructure will put us on the road to a 100% clean transportation sector in North Carolina.

Sincerely,

Aidan McDonald
532 phillips branch rd
Vilas, NC 28692
mcdonaldwc@appstate.edu
(794) 214-0563

This message was sent by KnowWho, as a service provider only, on behalf of the individual noted in the sender information.

From: Laurael Robichaud (laurael.robichaud@gmail.com) Sent You a Personal Message
To: [daq.NC_VWGrants](#)
Subject: [External] Use Volkswagen funds to electrify NC transportation
Date: Wednesday, December 06, 2017 5:22:29 AM

CAUTION: External email. Do not click links or open attachments unless verified. Send all suspicious email as an attachment to report.spam@nc.gov.

Dear Division of Air Quality,

I am writing to urge DEQ to wisely invest the \$92 million in Volkswagen settlement funds in electric vehicles and infrastructure. Taking advantage of these funds to jumpstart the electrification of North Carolina's transportation sector will mean less money sent out of state for petroleum, more in-state jobs, and cleaner air.

Specifically, I recommend that DEQ allocate the maximum allowable amount (15%) of the funds for electric vehicle charging infrastructure and installations. And I encourage DEQ to prioritize electric vehicles and buses for replacement whenever possible with the other 85% of the settlement funds. Doing so will maximize the local economic impact and the reduction of air pollution.

I encourage you to not use the funding for natural gas, propane or diesel vehicles. Further dependence on fossil fuels means more pollution. Only a transition to electric vehicles and investment in EV infrastructure will put us on the road to a 100% clean transportation sector in North Carolina.

Sincerely,

Laurael Robichaud
5416 Eno River Drive
Durham, NC 27704
laurael.robichaud@gmail.com
(919) 382-0408

This message was sent by KnowWho, as a service provider only, on behalf of the individual noted in the sender information.

From: Karen Mallam (karenmallam@yahoo.com) Sent You a Personal Message
To: [daq.NC_VWGrants](#)
Subject: [External] Use Volkswagen funds to electrify NC transportation
Date: Wednesday, December 06, 2017 5:16:48 AM

CAUTION: External email. Do not click links or open attachments unless verified. Send all suspicious email as an attachment to report.spam@nc.gov.

Dear Division of Air Quality,

I am writing to urge DEQ to wisely invest the \$92 million in Volkswagen settlement funds in electric vehicles and infrastructure. Taking advantage of these funds to jumpstart the electrification of North Carolina's transportation sector will mean less money sent out of state for petroleum, more in-state jobs, and cleaner air.

Specifically, I recommend that DEQ allocate the maximum allowable amount (15%) of the funds for electric vehicle charging infrastructure and installations. And I encourage DEQ to prioritize electric vehicles and buses for replacement whenever possible with the other 85% of the settlement funds. Doing so will maximize the local economic impact and the reduction of air pollution.

I encourage you to not use the funding for natural gas, propane or diesel vehicles. Further dependence on fossil fuels means more pollution. Only a transition to electric vehicles and investment in EV infrastructure will put us on the road to a 100% clean transportation sector in North Carolina.

Sincerely,

Karen Mallam
810 Buckner Springs Road
Siler City, NC 27344
karenmallam@yahoo.com
(919) 742-9953

This message was sent by KnowWho, as a service provider only, on behalf of the individual noted in the sender information.

From: Elizabeth Hay (ehay2@me.com) Sent You a Personal Message
To: [daq.NC_VWGrants](#)
Subject: [External] Use Volkswagen funds to electrify NC transportation
Date: Wednesday, December 06, 2017 5:05:57 AM

CAUTION: External email. Do not click links or open attachments unless verified. Send all suspicious email as an attachment to report.spam@nc.gov.

Dear Division of Air Quality,

I am writing to urge DEQ to wisely invest the \$92 million in Volkswagen settlement funds in electric vehicles and infrastructure. Taking advantage of these funds to jumpstart the electrification of North Carolina's transportation sector will mean less money sent out of state for petroleum, more in-state jobs, and cleaner air.

Specifically, I recommend that DEQ allocate the maximum allowable amount (15%) of the funds for electric vehicle charging infrastructure and installations. And I encourage DEQ to prioritize electric vehicles and buses for replacement whenever possible with the other 85% of the settlement funds. Doing so will maximize the local economic impact and the reduction of air pollution.

I encourage you to not use the funding for natural gas, propane or diesel vehicles. Further dependence on fossil fuels means more pollution. Only a transition to electric vehicles and investment in EV infrastructure will put us on the road to a 100% clean transportation sector in North Carolina.

Sincerely,

Elizabeth Hay
690 Junaluska Road
Andrews, NC 28901
ehay2@me.com
(828) 321-3496

This message was sent by KnowWho, as a service provider only, on behalf of the individual noted in the sender information.

From: Gene Hanson (gene.p.hanson@gmail.com) Sent You a Personal Message
To: [daq.NC_VWGrants](#)
Subject: [External] Use Volkswagen funds to electrify NC transportation
Date: Wednesday, December 06, 2017 4:28:01 AM

CAUTION: External email. Do not click links or open attachments unless verified. Send all suspicious email as an attachment to report.spam@nc.gov.

Dear Division of Air Quality,

I am writing to urge DEQ to wisely invest the \$92 million in Volkswagen settlement funds in electric vehicles and infrastructure. Taking advantage of these funds to jumpstart the electrification of North Carolina's transportation sector will mean less money sent out of state for petroleum, more in-state jobs, and cleaner air.

Specifically, I recommend that DEQ allocate the maximum allowable amount (15%) of the funds for electric vehicle charging infrastructure and installations. And I encourage DEQ to prioritize electric vehicles and buses for replacement whenever possible with the other 85% of the settlement funds. Doing so will maximize the local economic impact and the reduction of air pollution.

I encourage you to not use the funding for natural gas, propane or diesel vehicles. Further dependence on fossil fuels means more pollution. Only a transition to electric vehicles and investment in EV infrastructure will put us on the road to a 100% clean transportation sector in North Carolina.

Sincerely,

Gene Hanson
1905 Rolling Road
Chapel Hill, NC 27514
gene.p.hanson@gmail.com
(908) 240-2678

This message was sent by KnowWho, as a service provider only, on behalf of the individual noted in the sender information.

From: Marti Jenkins (martijenkins@me.com) Sent You a Personal Message
To: [daq.NC_VWGrants](#)
Subject: [External] Use Volkswagen funds to electrify NC transportation
Date: Wednesday, December 06, 2017 3:31:27 AM

CAUTION: External email. Do not click links or open attachments unless verified. Send all suspicious email as an attachment to report.spam@nc.gov.

Dear Division of Air Quality,

I am writing to urge DEQ to wisely invest the \$92 million in Volkswagen settlement funds in electric vehicles and infrastructure. Taking advantage of these funds to jumpstart the electrification of North Carolina's transportation sector will mean less money sent out of state for petroleum, more in-state jobs, and cleaner air.

Specifically, I recommend that DEQ allocate the maximum allowable amount (15%) of the funds for electric vehicle charging infrastructure and installations. And I encourage DEQ to prioritize electric vehicles and buses for replacement whenever possible with the other 85% of the settlement funds. Doing so will maximize the local economic impact and the reduction of air pollution.

I encourage you to not use the funding for natural gas, propane or diesel vehicles. Further dependence on fossil fuels means more pollution. Only a transition to electric vehicles and investment in EV infrastructure will put us on the road to a 100% clean transportation sector in North Carolina.

Sincerely,

Marti Jenkins
4810 Marlborough Way
Durham, NC 27713
martijenkins@me.com
(919) 699-4868

This message was sent by KnowWho, as a service provider only, on behalf of the individual noted in the sender information.

From: Robert Larick (creativesource007@msn.com) Sent You a Personal Message
To: [daq.NC_VWGrants](#)
Subject: [External] Use Volkswagen funds to electrify NC transportation
Date: Wednesday, December 06, 2017 2:33:37 AM

CAUTION: External email. Do not click links or open attachments unless verified. Send all suspicious email as an attachment to report.spam@nc.gov.

Dear Division of Air Quality,

I am writing to urge DEQ to wisely invest the \$92 million in Volkswagen settlement funds in electric vehicles and infrastructure. Taking advantage of these funds to jumpstart the electrification of North Carolina's transportation sector will mean less money sent out of state for petroleum, more in-state jobs, and cleaner air.

Specifically, I recommend that DEQ allocate the maximum allowable amount (15%) of the funds for electric vehicle charging infrastructure and installations. And I encourage DEQ to prioritize electric vehicles and buses for replacement whenever possible with the other 85% of the settlement funds. Doing so will maximize the local economic impact and the reduction of air pollution.

I encourage you to not use the funding for natural gas, propane or diesel vehicles. Further dependence on fossil fuels means more pollution. Only a transition to electric vehicles and investment in EV infrastructure will put us on the road to a 100% clean transportation sector in North Carolina.

Sincerely,

Robert Larick
5440 Allison La.
Charlotte, NC 28277
creativesource007@msn.com
(704) 321-1450

This message was sent by KnowWho, as a service provider only, on behalf of the individual noted in the sender information.

From: Lynne C. (catslc@aol.com) Sent You a Personal Message
To: [daq.NC_VWGrants](#)
Subject: [External] Use Volkswagen funds to electrify NC transportation
Date: Wednesday, December 06, 2017 2:01:53 AM

CAUTION: External email. Do not click links or open attachments unless verified. Send all suspicious email as an attachment to report.spam@nc.gov.

Dear Division of Air Quality,

I am writing to urge DEQ to wisely invest the \$92 million in Volkswagen settlement funds in electric vehicles and infrastructure. Taking advantage of these funds to jumpstart the electrification of North Carolina's transportation sector will mean less money sent out of state for petroleum, more in-state jobs, and cleaner air.

Specifically, I recommend that DEQ allocate the maximum allowable amount (15%) of the funds for electric vehicle charging infrastructure and installations. And I encourage DEQ to prioritize electric vehicles and buses for replacement whenever possible with the other 85% of the settlement funds. Doing so will maximize the local economic impact and the reduction of air pollution.

I encourage you to not use the funding for natural gas, propane or diesel vehicles. Further dependence on fossil fuels means more pollution. Only a transition to electric vehicles and investment in EV infrastructure will put us on the road to a 100% clean transportation sector in North Carolina.

Sincerely,

Lynne C.
5012 Lipscomb Dr.
Garner, NC 27529
catslc@aol.com
(919) 553-8612

This message was sent by KnowWho, as a service provider only, on behalf of the individual noted in the sender information.

From: Dana Morin (danamorin1971@gmail.com) Sent You a Personal Message
To: [daq.NC_VWGrants](#)
Subject: [External] Use Volkswagen funds to electrify NC transportation
Date: Wednesday, December 06, 2017 1:40:08 AM

CAUTION: External email. Do not click links or open attachments unless verified. Send all suspicious email as an attachment to report.spam@nc.gov.

Dear Division of Air Quality,

I am writing to urge DEQ to wisely invest the \$92 million in Volkswagen settlement funds in electric vehicles and infrastructure. Taking advantage of these funds to jumpstart the electrification of North Carolina's transportation sector will mean less money sent out of state for petroleum, more in-state jobs, and cleaner air.

Specifically, I recommend that DEQ allocate the maximum allowable amount (15%) of the funds for electric vehicle charging infrastructure and installations. And I encourage DEQ to prioritize electric vehicles and buses for replacement whenever possible with the other 85% of the settlement funds. Doing so will maximize the local economic impact and the reduction of air pollution.

I encourage you to not use the funding for natural gas, propane or diesel vehicles. Further dependence on fossil fuels means more pollution. Only a transition to electric vehicles and investment in EV infrastructure will put us on the road to a 100% clean transportation sector in North Carolina.

Sincerely,

Dana Morin
4123 Cascade St,
Terrell, NC 28682
danamorin1971@gmail.com
(239) 910-2519

This message was sent by KnowWho, as a service provider only, on behalf of the individual noted in the sender information.

From: WELDINE DOSSETT (weldine@gmail.com) Sent You a Personal Message
To: [daq.NC_VWGrants](#)
Subject: [External] Use Volkswagen funds to electrify NC transportation
Date: Wednesday, December 06, 2017 1:33:46 AM

CAUTION: External email. Do not click links or open attachments unless verified. Send all suspicious email as an attachment to report.spam@nc.gov.

Dear Division of Air Quality,

I am writing to urge DEQ to wisely invest the \$92 million in Volkswagen settlement funds in electric vehicles and infrastructure. Taking advantage of these funds to jumpstart the electrification of North Carolina's transportation sector will mean less money sent out of state for petroleum, more in-state jobs, and cleaner air.

Specifically, I recommend that DEQ allocate the maximum allowable amount (15%) of the funds for electric vehicle charging infrastructure and installations. And I encourage DEQ to prioritize electric vehicles and buses for replacement whenever possible with the other 85% of the settlement funds. Doing so will maximize the local economic impact and the reduction of air pollution.

I encourage you to not use the funding for natural gas, propane or diesel vehicles. Further dependence on fossil fuels means more pollution. Only a transition to electric vehicles and investment in EV infrastructure will put us on the road to a 100% clean transportation sector in North Carolina.

Sincerely,

WELDINE DOSSETT
415 ABERDEEN TERRACE
GREENSBORO, NC 27403
weldine@gmail.com
(336) 500-3846

This message was sent by KnowWho, as a service provider only, on behalf of the individual noted in the sender information.

From: Judith Foster (jafoster46@icloud.com) Sent You a Personal Message
To: [daq.NC_VWGrants](#)
Subject: [External] Use Volkswagen funds to electrify NC transportation
Date: Wednesday, December 06, 2017 1:25:44 AM

CAUTION: External email. Do not click links or open attachments unless verified. Send all suspicious email as an attachment to report.spam@nc.gov.

Dear Division of Air Quality,

I am writing to urge DEQ to wisely invest the \$92 million in Volkswagen settlement funds in electric vehicles and infrastructure. Taking advantage of these funds to jumpstart the electrification of North Carolina's transportation sector will mean less money sent out of state for petroleum, more in-state jobs, and cleaner air.

Specifically, I recommend that DEQ allocate the maximum allowable amount (15%) of the funds for electric vehicle charging infrastructure and installations. And I encourage DEQ to prioritize electric vehicles and buses for replacement whenever possible with the other 85% of the settlement funds. Doing so will maximize the local economic impact and the reduction of air pollution.

I encourage you to not use the funding for natural gas, propane or diesel vehicles. Further dependence on fossil fuels means more pollution. Only a transition to electric vehicles and investment in EV infrastructure will put us on the road to a 100% clean transportation sector in North Carolina.

Sincerely,

Judith Foster
5409 Amberhill Drive
Greensboro, NC 27455
jafoster46@icloud.com
(336) 288-6442

This message was sent by KnowWho, as a service provider only, on behalf of the individual noted in the sender information.

From: Harrison Curtis (bud.curtis@gmail.com) Sent You a Personal Message
To: [daq.NC_VWGrants](#)
Subject: [External] Use Volkswagen funds to electrify NC transportation
Date: Wednesday, December 06, 2017 1:10:59 AM

CAUTION: External email. Do not click links or open attachments unless verified. Send all suspicious email as an attachment to report.spam@nc.gov.

Dear Division of Air Quality,

I am writing to urge DEQ to wisely invest the \$92 million in Volkswagen settlement funds in electric vehicles and infrastructure. Taking advantage of these funds to jumpstart the electrification of North Carolina's transportation sector will mean less money sent out of state for petroleum, more in-state jobs, and cleaner air.

Specifically, I recommend that DEQ allocate the maximum allowable amount (15%) of the funds for electric vehicle charging infrastructure and installations. And I encourage DEQ to prioritize electric vehicles and buses for replacement whenever possible with the other 85% of the settlement funds. Doing so will maximize the local economic impact and the reduction of air pollution.

I encourage you to not use the funding for natural gas, propane or diesel vehicles. Further dependence on fossil fuels means more pollution. Only a transition to electric vehicles and investment in EV infrastructure will put us on the road to a 100% clean transportation sector in North Carolina.

Sincerely,

Harrison Curtis
702 Tarragon Ct.
New Bern, NC 28562
bud.curtis@gmail.com
(252) 288-6528

This message was sent by KnowWho, as a service provider only, on behalf of the individual noted in the sender information.

From: Al Meadowcroft (teriandal@aol.com) Sent You a Personal Message
To: [daq.NC_VWGrants](#)
Subject: [External] Use Volkswagen funds to electrify NC transportation
Date: Wednesday, December 06, 2017 12:50:20 AM

CAUTION: External email. Do not click links or open attachments unless verified. Send all suspicious email as an attachment to report.spam@nc.gov.

Dear Division of Air Quality,

I am writing to urge DEQ to wisely invest the \$92 million in Volkswagen settlement funds in electric vehicles and infrastructure. Taking advantage of these funds to jumpstart the electrification of North Carolina's transportation sector will mean less money sent out of state for petroleum, more in-state jobs, and cleaner air.

Specifically, I recommend that DEQ allocate the maximum allowable amount (15%) of the funds for electric vehicle charging infrastructure and installations. And I encourage DEQ to prioritize electric vehicles and buses for replacement whenever possible with the other 85% of the settlement funds. Doing so will maximize the local economic impact and the reduction of air pollution.

I encourage you to not use the funding for natural gas, propane or diesel vehicles. Further dependence on fossil fuels means more pollution. Only a transition to electric vehicles and investment in EV infrastructure will put us on the road to a 100% clean transportation sector in North Carolina.

Sincerely,

Al Meadowcroft
518 Plymouth Dr.
Wilmington, NC 28405
teriandal@aol.com
(910) 431-9691

This message was sent by KnowWho, as a service provider only, on behalf of the individual noted in the sender information.

From: martin feinstein (martin_feinstein@unc.edu) Sent You a Personal Message
To: [daq.NC_VWGrants](#)
Subject: [External] Use Volkswagen funds to electrify NC transportation
Date: Wednesday, December 06, 2017 12:25:50 AM

CAUTION: External email. Do not click links or open attachments unless verified. Send all suspicious email as an attachment to report.spam@nc.gov.

Dear Division of Air Quality,

I am writing to urge DEQ to wisely invest the \$92 million in Volkswagen settlement funds in electric vehicles and infrastructure. Taking advantage of these funds to jumpstart the electrification of North Carolina's transportation sector will mean less money sent out of state for petroleum, more in-state jobs, and cleaner air.

Specifically, I recommend that DEQ allocate the maximum allowable amount (15%) of the funds for electric vehicle charging infrastructure and installations. And I encourage DEQ to prioritize electric vehicles and buses for replacement whenever possible with the other 85% of the settlement funds. Doing so will maximize the local economic impact and the reduction of air pollution.

I encourage you to not use the funding for natural gas, propane or diesel vehicles. Further dependence on fossil fuels means more pollution. Only a transition to electric vehicles and investment in EV infrastructure will put us on the road to a 100% clean transportation sector in North Carolina.

Sincerely,

martin feinstein
400 coolidge street
chapel hill, NC 27516
martin_feinstein@unc.edu
(919) 933-3089

This message was sent by KnowWho, as a service provider only, on behalf of the individual noted in the sender information.

From: Destinee Means (ddm0706@gmail.com) Sent You a Personal Message
To: [daq.NC_VWGrants](#)
Subject: [External] Use Volkswagen funds to electrify NC transportation
Date: Wednesday, December 06, 2017 12:11:38 AM

CAUTION: External email. Do not click links or open attachments unless verified. Send all suspicious email as an attachment to report.spam@nc.gov.

Dear Division of Air Quality,

I am writing to urge DEQ to wisely invest the \$92 million in Volkswagen settlement funds in electric vehicles and infrastructure. Taking advantage of these funds to jumpstart the electrification of North Carolina's transportation sector will mean less money sent out of state for petroleum, more in-state jobs, and cleaner air.

Specifically, I recommend that DEQ allocate the maximum allowable amount (15%) of the funds for electric vehicle charging infrastructure and installations. And I encourage DEQ to prioritize electric vehicles and buses for replacement whenever possible with the other 85% of the settlement funds. Doing so will maximize the local economic impact and the reduction of air pollution.

I encourage you to not use the funding for natural gas, propane or diesel vehicles. Further dependence on fossil fuels means more pollution. Only a transition to electric vehicles and investment in EV infrastructure will put us on the road to a 100% clean transportation sector in North Carolina.

Sincerely,

Destinee Means
510 N Wilmington St #509
Destinee, NC 27604
ddm0706@gmail.com
(252) 259-5668

This message was sent by KnowWho, as a service provider only, on behalf of the individual noted in the sender information.

From: Eleanor Bly Underdown (ebunderdown@att.net) Sent You a Personal Message
To: [daq.NC_VWGrants](#)
Subject: [External] Use Volkswagen funds to electrify NC transportation
Date: Tuesday, December 05, 2017 11:37:18 PM

CAUTION: External email. Do not click links or open attachments unless verified. Send all suspicious email as an attachment to report.spam@nc.gov.

Dear Division of Air Quality,

I am writing to urge DEQ to wisely invest the \$92 million in Volkswagen settlement funds in electric vehicles and infrastructure. Taking advantage of these funds to jumpstart the electrification of North Carolina's transportation sector will mean less money sent out of state for petroleum, more in-state jobs, and cleaner air.

Specifically, I recommend that DEQ allocate the maximum allowable amount (15%) of the funds for electric vehicle charging infrastructure and installations. And I encourage DEQ to prioritize electric vehicles and buses for replacement whenever possible with the other 85% of the settlement funds. Doing so will maximize the local economic impact and the reduction of air pollution.

I encourage you to not use the funding for natural gas, propane or diesel vehicles. Further dependence on fossil fuels means more pollution. Only a transition to electric vehicles and investment in EV infrastructure will put us on the road to a 100% clean transportation sector in North Carolina.

Sincerely,

Eleanor Bly Underdown
1015K Cedar Hills Ct SE
Lenoir, NC 28645
ebunderdown@att.net
(828) 757-7912

This message was sent by KnowWho, as a service provider only, on behalf of the individual noted in the sender information.

From: Donna Newman (dnewman27606@yahoo.com) Sent You a Personal Message
To: [daq.NC_VWGrants](#)
Subject: [External] Use Volkswagen funds to electrify NC transportation
Date: Tuesday, December 05, 2017 11:27:49 PM

CAUTION: External email. Do not click links or open attachments unless verified. Send all suspicious email as an attachment to report.spam@nc.gov.

Dear Division of Air Quality,

I am writing to urge DEQ to wisely invest the \$92 million in Volkswagen settlement funds in electric vehicles and infrastructure. Taking advantage of these funds to jumpstart the electrification of North Carolina's transportation sector will mean less money sent out of state for petroleum, more in-state jobs, and cleaner air.

Specifically, I recommend that DEQ allocate the maximum allowable amount (15%) of the funds for electric vehicle charging infrastructure and installations. And I encourage DEQ to prioritize electric vehicles and buses for replacement whenever possible with the other 85% of the settlement funds. Doing so will maximize the local economic impact and the reduction of air pollution.

I encourage you to not use the funding for natural gas, propane or diesel vehicles. Further dependence on fossil fuels means more pollution. Only a transition to electric vehicles and investment in EV infrastructure will put us on the road to a 100% clean transportation sector in North Carolina.

Sincerely,

Donna Newman
710-D Powell Drive
Donna, NC 27606
dnewman27606@yahoo.com
(919) 222-2222

This message was sent by KnowWho, as a service provider only, on behalf of the individual noted in the sender information.

From: Fred Martin (famiv@yahoo.com) Sent You a Personal Message
To: [daq.NC_VWGrants](#)
Subject: [External] Use Volkswagen funds to electrify NC transportation
Date: Tuesday, December 05, 2017 11:19:47 PM

CAUTION: External email. Do not click links or open attachments unless verified. Send all suspicious email as an attachment to report.spam@nc.gov.

Dear Division of Air Quality,

I am writing to urge DEQ to wisely invest the \$92 million in Volkswagen settlement funds in electric vehicles and infrastructure. Taking advantage of these funds to jumpstart the electrification of North Carolina's transportation sector will mean less money sent out of state for petroleum, more in-state jobs, and cleaner air.

Specifically, I recommend that DEQ allocate the maximum allowable amount (15%) of the funds for electric vehicle charging infrastructure and installations. And I encourage DEQ to prioritize electric vehicles and buses for replacement whenever possible with the other 85% of the settlement funds. Doing so will maximize the local economic impact and the reduction of air pollution.

I encourage you to not use the funding for natural gas, propane or diesel vehicles. Further dependence on fossil fuels means more pollution. Only a transition to electric vehicles and investment in EV infrastructure will put us on the road to a 100% clean transportation sector in North Carolina.

Sincerely,

Fred Martin
3215 Ravencliff Dr.
Charlotte, NC 28226
famiv@yahoo.com
(704) 752-0182

This message was sent by KnowWho, as a service provider only, on behalf of the individual noted in the sender information.

From: Pam Burns (pamburns68@gmail.com) Sent You a Personal Message
To: [daq.NC_VWGrants](#)
Subject: [External] Use Volkswagen funds to electrify NC transportation
Date: Tuesday, December 05, 2017 11:15:58 PM

CAUTION: External email. Do not click links or open attachments unless verified. Send all suspicious email as an attachment to report.spam@nc.gov.

Dear Division of Air Quality,

I am writing to urge DEQ to wisely invest the \$92 million in Volkswagen settlement funds in electric vehicles and infrastructure. Taking advantage of these funds to jumpstart the electrification of North Carolina's transportation sector will mean less money sent out of state for petroleum, more in-state jobs, and cleaner air.

Specifically, I recommend that DEQ allocate the maximum allowable amount (15%) of the funds for electric vehicle charging infrastructure and installations. And I encourage DEQ to prioritize electric vehicles and buses for replacement whenever possible with the other 85% of the settlement funds. Doing so will maximize the local economic impact and the reduction of air pollution.

I encourage you to not use the funding for natural gas, propane or diesel vehicles. Further dependence on fossil fuels means more pollution. Only a transition to electric vehicles and investment in EV infrastructure will put us on the road to a 100% clean transportation sector in North Carolina.

Sincerely,

Pam Burns
104 Dowington Lane
Cary, NC 27519
pamburns68@gmail.com
(919) 651-9790

This message was sent by KnowWho, as a service provider only, on behalf of the individual noted in the sender information.

From: Barbara Harvey (barharvey@aol.com) Sent You a Personal Message
To: [daq.NC_VWGrants](#)
Subject: [External] Use Volkswagen funds to electrify NC transportation
Date: Tuesday, December 05, 2017 11:07:54 PM

CAUTION: External email. Do not click links or open attachments unless verified. Send all suspicious email as an attachment to report.spam@nc.gov.

Dear Division of Air Quality,

I am writing to urge DEQ to wisely invest the \$92 million in Volkswagen settlement funds in electric vehicles and infrastructure. Taking advantage of these funds to jumpstart the electrification of North Carolina's transportation sector will mean less money sent out of state for petroleum, more in-state jobs, and cleaner air.

Specifically, I recommend that DEQ allocate the maximum allowable amount (15%) of the funds for electric vehicle charging infrastructure and installations. And I encourage DEQ to prioritize electric vehicles and buses for replacement whenever possible with the other 85% of the settlement funds. Doing so will maximize the local economic impact and the reduction of air pollution.

I encourage you to not use the funding for natural gas, propane or diesel vehicles. Further dependence on fossil fuels means more pollution. Only a transition to electric vehicles and investment in EV infrastructure will put us on the road to a 100% clean transportation sector in North Carolina.

Sincerely,

Barbara Harvey
102 Ayr Court,
Cary, NC 27511
barharvey@aol.com
(919) 388-7618

This message was sent by KnowWho, as a service provider only, on behalf of the individual noted in the sender information.

From: Taylor Engle (englet@uni.edu) Sent You a Personal Message
To: [daq.NC_VWGrants](#)
Subject: [External] Use Volkswagen funds to electrify NC transportation
Date: Tuesday, December 05, 2017 11:00:53 PM

CAUTION: External email. Do not click links or open attachments unless verified. Send all suspicious email as an attachment to report.spam@nc.gov.

Dear Division of Air Quality,

I am writing to urge DEQ to wisely invest the \$92 million in Volkswagen settlement funds in electric vehicles and infrastructure. Taking advantage of these funds to jumpstart the electrification of North Carolina's transportation sector will mean less money sent out of state for petroleum, more in-state jobs, and cleaner air.

Specifically, I recommend that DEQ allocate the maximum allowable amount (15%) of the funds for electric vehicle charging infrastructure and installations. And I encourage DEQ to prioritize electric vehicles and buses for replacement whenever possible with the other 85% of the settlement funds. Doing so will maximize the local economic impact and the reduction of air pollution.

I encourage you to not use the funding for natural gas, propane or diesel vehicles. Further dependence on fossil fuels means more pollution. Only a transition to electric vehicles and investment in EV infrastructure will put us on the road to a 100% clean transportation sector in North Carolina.

Sincerely,

Taylor Engle
5855 Old Oak Ridge Rd
Greensboro, NC 27410
englet@uni.edu
(563) 271-7382

This message was sent by KnowWho, as a service provider only, on behalf of the individual noted in the sender information.

From: Courtney Distelrath (courtneywilson453@gmail.com) Sent You a Personal Message
To: [daq.NC_VWGrants](#)
Subject: [External] Use Volkswagen funds to electrify NC transportation
Date: Tuesday, December 05, 2017 10:52:14 PM

CAUTION: External email. Do not click links or open attachments unless verified. Send all suspicious email as an attachment to report.spam@nc.gov.

Dear Division of Air Quality,

I am writing to urge DEQ to wisely invest the \$92 million in Volkswagen settlement funds in electric vehicles and infrastructure. Taking advantage of these funds to jumpstart the electrification of North Carolina's transportation sector will mean less money sent out of state for petroleum, more in-state jobs, and cleaner air.

Specifically, I recommend that DEQ allocate the maximum allowable amount (15%) of the funds for electric vehicle charging infrastructure and installations. And I encourage DEQ to prioritize electric vehicles and buses for replacement whenever possible with the other 85% of the settlement funds. Doing so will maximize the local economic impact and the reduction of air pollution.

I encourage you to not use the funding for natural gas, propane or diesel vehicles. Further dependence on fossil fuels means more pollution. Only a transition to electric vehicles and investment in EV infrastructure will put us on the road to a 100% clean transportation sector in North Carolina.

Sincerely,

Courtney Distelrath
32 Avellino Road
Courtney, NC 28307
courtneywilson453@gmail.com
(910) 705-7733

This message was sent by KnowWho, as a service provider only, on behalf of the individual noted in the sender information.

From: Agnes Crews (aggiereads@gmail.com) Sent You a Personal Message
To: [daq.NC_VWGrants](#)
Subject: [External] Use Volkswagen funds to electrify NC transportation
Date: Tuesday, December 05, 2017 10:41:26 PM

CAUTION: External email. Do not click links or open attachments unless verified. Send all suspicious email as an attachment to report.spam@nc.gov.

Dear Division of Air Quality,

I am writing to urge DEQ to wisely invest the \$92 million in Volkswagen settlement funds in electric vehicles and infrastructure. Taking advantage of these funds to jumpstart the electrification of North Carolina's transportation sector will mean less money sent out of state for petroleum, more in-state jobs, and cleaner air.

Specifically, I recommend that DEQ allocate the maximum allowable amount (15%) of the funds for electric vehicle charging infrastructure and installations. And I encourage DEQ to prioritize electric vehicles and buses for replacement whenever possible with the other 85% of the settlement funds. Doing so will maximize the local economic impact and the reduction of air pollution.

I encourage you to not use the funding for natural gas, propane or diesel vehicles. Further dependence on fossil fuels means more pollution. Only a transition to electric vehicles and investment in EV infrastructure will put us on the road to a 100% clean transportation sector in North Carolina.

Sincerely,

Agnes Crews
421 Ray Rd
Chapel Hill, NC 27516
aggiereads@gmail.com
(919) 933-0502

This message was sent by KnowWho, as a service provider only, on behalf of the individual noted in the sender information.

From: Jake Armour (jarmour@uncc.edu) Sent You a Personal Message
To: [daq.NC_VWGrants](#)
Subject: [External] Use Volkswagen funds to electrify NC transportation
Date: Tuesday, December 05, 2017 10:39:24 PM

CAUTION: External email. Do not click links or open attachments unless verified. Send all suspicious email as an attachment to report.spam@nc.gov.

Dear Division of Air Quality,

I am writing to urge DEQ to wisely invest the \$92 million in Volkswagen settlement funds in electric vehicles and infrastructure. Taking advantage of these funds to jumpstart the electrification of North Carolina's transportation sector will mean less money sent out of state for petroleum, more in-state jobs, and cleaner air.

Specifically, I recommend that DEQ allocate the maximum allowable amount (15%) of the funds for electric vehicle charging infrastructure and installations. And I encourage DEQ to prioritize electric vehicles and buses for replacement whenever possible with the other 85% of the settlement funds. Doing so will maximize the local economic impact and the reduction of air pollution.

I encourage you to not use the funding for natural gas, propane or diesel vehicles. Further dependence on fossil fuels means more pollution. Only a transition to electric vehicles and investment in EV infrastructure will put us on the road to a 100% clean transportation sector in North Carolina.

Sincerely,

Jake Armour
12601 Moore's Chapel Rd
Charlotte, NC 28214
jarmour@uncc.edu
(704) 393-7096

This message was sent by KnowWho, as a service provider only, on behalf of the individual noted in the sender information.

From: Brian Peltier (bepeltier@bellsouth.net) Sent You a Personal Message
To: [daq.NC_VWGrants](#)
Subject: [External] Use Volkswagen funds to electrify NC transportation
Date: Tuesday, December 05, 2017 10:27:38 PM

CAUTION: External email. Do not click links or open attachments unless verified. Send all suspicious email as an attachment to report.spam@nc.gov.

Dear Division of Air Quality,

I am writing to urge DEQ to wisely invest the \$92 million in Volkswagen settlement funds in electric vehicles and infrastructure. Taking advantage of these funds to jumpstart the electrification of North Carolina's transportation sector will mean less money sent out of state for petroleum, more in-state jobs, and cleaner air.

Specifically, I recommend that DEQ allocate the maximum allowable amount (15%) of the funds for electric vehicle charging infrastructure and installations. And I encourage DEQ to prioritize electric vehicles and buses for replacement whenever possible with the other 85% of the settlement funds. Doing so will maximize the local economic impact and the reduction of air pollution.

I encourage you to not use the funding for natural gas, propane or diesel vehicles. Further dependence on fossil fuels means more pollution. Only a transition to electric vehicles and investment in EV infrastructure will put us on the road to a 100% clean transportation sector in North Carolina.

Sincerely,

Brian Peltier
74 ebens Cove
Barnardsville, NC 28709
bepeltier@bellsouth.net
(828) 367-3770

This message was sent by KnowWho, as a service provider only, on behalf of the individual noted in the sender information.

From: Sherrell Cuthbertson (azell2001@gmail.com) Sent You a Personal Message
To: [daq.NC_VWGrants](#)
Subject: [External] Use Volkswagen funds to electrify NC transportation
Date: Tuesday, December 05, 2017 10:24:54 PM

CAUTION: External email. Do not click links or open attachments unless verified. Send all suspicious email as an attachment to report.spam@nc.gov.

Dear Division of Air Quality,

I am writing to urge DEQ to wisely invest the \$92 million in Volkswagen settlement funds in electric vehicles and infrastructure. Taking advantage of these funds to jumpstart the electrification of North Carolina's transportation sector will mean less money sent out of state for petroleum, more in-state jobs, and cleaner air.

Specifically, I recommend that DEQ allocate the maximum allowable amount (15%) of the funds for electric vehicle charging infrastructure and installations. And I encourage DEQ to prioritize electric vehicles and buses for replacement whenever possible with the other 85% of the settlement funds. Doing so will maximize the local economic impact and the reduction of air pollution.

I encourage you to not use the funding for natural gas, propane or diesel vehicles. Further dependence on fossil fuels means more pollution. Only a transition to electric vehicles and investment in EV infrastructure will put us on the road to a 100% clean transportation sector in North Carolina.

Sincerely,

Sherrell Cuthbertson
15 Future Dr, Apt 3-G
Asheville, NC 28803
azell2001@gmail.com
(828) 989-6654

This message was sent by KnowWho, as a service provider only, on behalf of the individual noted in the sender information.

From: joseph magura (magura@fac.unc.edu) Sent You a Personal Message
To: [daq.NC_VWGrants](#)
Subject: [External] Use Volkswagen funds to electrify NC transportation
Date: Tuesday, December 05, 2017 10:24:09 PM

CAUTION: External email. Do not click links or open attachments unless verified. Send all suspicious email as an attachment to report.spam@nc.gov.

Dear Division of Air Quality,

I am writing to urge DEQ to wisely invest the \$92 million in Volkswagen settlement funds in electric vehicles and infrastructure. Taking advantage of these funds to jumpstart the electrification of North Carolina's transportation sector will mean less money sent out of state for petroleum, more in-state jobs, and cleaner air.

Specifically, I recommend that DEQ allocate the maximum allowable amount (15%) of the funds for electric vehicle charging infrastructure and installations. And I encourage DEQ to prioritize electric vehicles and buses for replacement whenever possible with the other 85% of the settlement funds. Doing so will maximize the local economic impact and the reduction of air pollution.

I encourage you to not use the funding for natural gas, propane or diesel vehicles. Further dependence on fossil fuels means more pollution. Only a transition to electric vehicles and investment in EV infrastructure will put us on the road to a 100% clean transportation sector in North Carolina.

Sincerely,

joseph magura
5817 Henner Place
Durham, NC 27713
magura@fac.unc.edu
(919) 904-0075

This message was sent by KnowWho, as a service provider only, on behalf of the individual noted in the sender information.

From: Rosa Orr (orrr7329@gmail.com) Sent You a Personal Message
To: [daq.NC_VWGrants](#)
Subject: [External] Use Volkswagen funds to electrify NC transportation
Date: Tuesday, December 05, 2017 10:12:48 PM

CAUTION: External email. Do not click links or open attachments unless verified. Send all suspicious email as an attachment to report.spam@nc.gov.

Dear Division of Air Quality,

I am writing to urge DEQ to wisely invest the \$92 million in Volkswagen settlement funds in electric vehicles and infrastructure. Taking advantage of these funds to jumpstart the electrification of North Carolina's transportation sector will mean less money sent out of state for petroleum, more in-state jobs, and cleaner air.

Specifically, I recommend that DEQ allocate the maximum allowable amount (15%) of the funds for electric vehicle charging infrastructure and installations. And I encourage DEQ to prioritize electric vehicles and buses for replacement whenever possible with the other 85% of the settlement funds. Doing so will maximize the local economic impact and the reduction of air pollution.

I encourage you to not use the funding for natural gas, propane or diesel vehicles. Further dependence on fossil fuels means more pollution. Only a transition to electric vehicles and investment in EV infrastructure will put us on the road to a 100% clean transportation sector in North Carolina.

Sincerely,

Rosa Orr
25 Wayward Path
Candler, NC 28715
orrr7329@gmail.com
(828) 665-4422

This message was sent by KnowWho, as a service provider only, on behalf of the individual noted in the sender information.

From: Anne Lanzi (agl2201@gmail.com) Sent You a Personal Message
To: daq.NC_VWGrants
Subject: [External] Use Volkswagen funds to electrify NC transportation
Date: Tuesday, December 05, 2017 10:11:08 PM

CAUTION: External email. Do not click links or open attachments unless verified. Send all suspicious email as an attachment to report.spam@nc.gov.

Dear Division of Air Quality,

I am writing to urge DEQ to wisely invest the \$92 million in Volkswagen settlement funds in electric vehicles and infrastructure. Taking advantage of these funds to jumpstart the electrification of North Carolina's transportation sector will mean less money sent out of state for petroleum, more in-state jobs, and cleaner air.

Specifically, I recommend that DEQ allocate the maximum allowable amount (15%) of the funds for electric vehicle charging infrastructure and installations. And I encourage DEQ to prioritize electric vehicles and buses for replacement whenever possible with the other 85% of the settlement funds. Doing so will maximize the local economic impact and the reduction of air pollution.

I encourage you to not use the funding for natural gas, propane or diesel vehicles. Further dependence on fossil fuels means more pollution. Only a transition to electric vehicles and investment in EV infrastructure will put us on the road to a 100% clean transportation sector in North Carolina.

Sincerely,

Anne Lanzi
155 Michigan Ave
Asheville, NC 28806
agl2201@gmail.com
(828) 337-5155

This message was sent by KnowWho, as a service provider only, on behalf of the individual noted in the sender information.

From: Susan Pope (susanmpope@aol.com) Sent You a Personal Message
To: [daq.NC_VWGrants](#)
Subject: [External] Use Volkswagen funds to electrify NC transportation
Date: Tuesday, December 05, 2017 10:06:37 PM

CAUTION: External email. Do not click links or open attachments unless verified. Send all suspicious email as an attachment to report.spam@nc.gov.

Dear Division of Air Quality,

I am writing to urge DEQ to wisely invest the \$92 million in Volkswagen settlement funds in electric vehicles and infrastructure. Taking advantage of these funds to jumpstart the electrification of North Carolina's transportation sector will mean less money sent out of state for petroleum, more in-state jobs, and cleaner air.

Specifically, I recommend that DEQ allocate the maximum allowable amount (15%) of the funds for electric vehicle charging infrastructure and installations. And I encourage DEQ to prioritize electric vehicles and buses for replacement whenever possible with the other 85% of the settlement funds. Doing so will maximize the local economic impact and the reduction of air pollution.

I encourage you to not use the funding for natural gas, propane or diesel vehicles. Further dependence on fossil fuels means more pollution. Only a transition to electric vehicles and investment in EV infrastructure will put us on the road to a 100% clean transportation sector in North Carolina.

Sincerely,

Susan Pope
5001 Putter Lane
Susan, NC 27949
susanmpope@aol.com
(252) 255-2893

This message was sent by KnowWho, as a service provider only, on behalf of the individual noted in the sender information.

From: Sara Donatich (sara.donatich@gmail.com) Sent You a Personal Message
To: [daq.NC_VWGrants](#)
Subject: [External] Use Volkswagen funds to electrify NC transportation
Date: Tuesday, December 05, 2017 10:04:34 PM

CAUTION: External email. Do not click links or open attachments unless verified. Send all suspicious email as an attachment to report.spam@nc.gov.

Dear Division of Air Quality,

I am writing to urge DEQ to wisely invest the \$92 million in Volkswagen settlement funds in electric vehicles and infrastructure. Taking advantage of these funds to jumpstart the electrification of North Carolina's transportation sector will mean less money sent out of state for petroleum, more in-state jobs, and cleaner air.

Specifically, I recommend that DEQ allocate the maximum allowable amount (15%) of the funds for electric vehicle charging infrastructure and installations. And I encourage DEQ to prioritize electric vehicles and buses for replacement whenever possible with the other 85% of the settlement funds. Doing so will maximize the local economic impact and the reduction of air pollution.

I encourage you to not use the funding for natural gas, propane or diesel vehicles. Further dependence on fossil fuels means more pollution. Only a transition to electric vehicles and investment in EV infrastructure will put us on the road to a 100% clean transportation sector in North Carolina.

Sincerely,

Sara Donatich
3013 Dorner Circle Apt c
Raleigh, NC 27606
sara.donatich@gmail.com
(631) 848-8580

This message was sent by KnowWho, as a service provider only, on behalf of the individual noted in the sender information.

From: lyda karrh (lydakarrh@me.com) Sent You a Personal Message
To: [daq.NC_VWGrants](#)
Subject: [External] Use Volkswagen funds to electrify NC transportation
Date: Tuesday, December 05, 2017 10:04:03 PM

CAUTION: External email. Do not click links or open attachments unless verified. Send all suspicious email as an attachment to report.spam@nc.gov.

Dear Division of Air Quality,

I am writing to urge DEQ to wisely invest the \$92 million in Volkswagen settlement funds in electric vehicles and infrastructure. Taking advantage of these funds to jumpstart the electrification of North Carolina's transportation sector will mean less money sent out of state for petroleum, more in-state jobs, and cleaner air.

Specifically, I recommend that DEQ allocate the maximum allowable amount (15%) of the funds for electric vehicle charging infrastructure and installations. And I encourage DEQ to prioritize electric vehicles and buses for replacement whenever possible with the other 85% of the settlement funds. Doing so will maximize the local economic impact and the reduction of air pollution.

I encourage you to not use the funding for natural gas, propane or diesel vehicles. Further dependence on fossil fuels means more pollution. Only a transition to electric vehicles and investment in EV infrastructure will put us on the road to a 100% clean transportation sector in North Carolina.

Sincerely,

lyda karrh
109 hamburg mountain road
weaverville, NC 28787
lydakarrh@me.com
(828) 484-4597

This message was sent by KnowWho, as a service provider only, on behalf of the individual noted in the sender information.

From: J. L. Wakefield (jwakefield1@triad.rr.com) Sent You a Personal Message
To: daq.NC_VWGrants
Subject: [External] Use Volkswagen funds to electrify NC transportation
Date: Tuesday, December 05, 2017 10:02:48 PM

CAUTION: External email. Do not click links or open attachments unless verified. Send all suspicious email as an attachment to report.spam@nc.gov.

Dear Division of Air Quality,

I am writing to urge DEQ to wisely invest the \$92 million in Volkswagen settlement funds in electric vehicles and infrastructure. Taking advantage of these funds to jumpstart the electrification of North Carolina's transportation sector will mean less money sent out of state for petroleum, more in-state jobs, and cleaner air.

Specifically, I recommend that DEQ allocate the maximum allowable amount (15%) of the funds for electric vehicle charging infrastructure and installations. And I encourage DEQ to prioritize electric vehicles and buses for replacement whenever possible with the other 85% of the settlement funds. Doing so will maximize the local economic impact and the reduction of air pollution.

I encourage you to not use the funding for natural gas, propane or diesel vehicles. Further dependence on fossil fuels means more pollution. Only a transition to electric vehicles and investment in EV infrastructure will put us on the road to a 100% clean transportation sector in North Carolina.

Sincerely,

J. L. Wakefield
252 Oakwood Ct
Winston-Salem, NC 27103
jwakefield1@triad.rr.com
(336) 722-0587

This message was sent by KnowWho, as a service provider only, on behalf of the individual noted in the sender information.

From: Alice Payne (al2payne@yahoo.com) Sent You a Personal Message
To: [daq.NC_VWGrants](#)
Subject: [External] Use Volkswagen funds to electrify NC transportation
Date: Tuesday, December 05, 2017 10:00:17 PM

CAUTION: External email. Do not click links or open attachments unless verified. Send all suspicious email as an attachment to report.spam@nc.gov.

Dear Division of Air Quality,

I am writing to urge DEQ to wisely invest the \$92 million in Volkswagen settlement funds in electric vehicles and infrastructure. Taking advantage of these funds to jumpstart the electrification of North Carolina's transportation sector will mean less money sent out of state for petroleum, more in-state jobs, and cleaner air.

Specifically, I recommend that DEQ allocate the maximum allowable amount (15%) of the funds for electric vehicle charging infrastructure and installations. And I encourage DEQ to prioritize electric vehicles and buses for replacement whenever possible with the other 85% of the settlement funds. Doing so will maximize the local economic impact and the reduction of air pollution.

I encourage you to not use the funding for natural gas, propane or diesel vehicles. Further dependence on fossil fuels means more pollution. Only a transition to electric vehicles and investment in EV infrastructure will put us on the road to a 100% clean transportation sector in North Carolina.

Sincerely,

Alice Payne
1645 US Hwy 258 N
Kinston, NC 28504
al2payne@yahoo.com
(919) 920-0513

This message was sent by KnowWho, as a service provider only, on behalf of the individual noted in the sender information.

From: renee Skudra (renees52@aol.com) Sent You a Personal Message
To: [daq.NC_VWGrants](#)
Subject: [External] Use Volkswagen funds to electrify NC transportation
Date: Tuesday, December 05, 2017 9:57:31 PM

CAUTION: External email. Do not click links or open attachments unless verified. Send all suspicious email as an attachment to report.spam@nc.gov.

Dear Division of Air Quality,

I am writing to urge DEQ to wisely invest the \$92 million in Volkswagen settlement funds in electric vehicles and infrastructure. Taking advantage of these funds to jumpstart the electrification of North Carolina's transportation sector will mean less money sent out of state for petroleum, more in-state jobs, and cleaner air.

Specifically, I recommend that DEQ allocate the maximum allowable amount (15%) of the funds for electric vehicle charging infrastructure and installations. And I encourage DEQ to prioritize electric vehicles and buses for replacement whenever possible with the other 85% of the settlement funds. Doing so will maximize the local economic impact and the reduction of air pollution.

I encourage you to not use the funding for natural gas, propane or diesel vehicles. Further dependence on fossil fuels means more pollution. Only a transition to electric vehicles and investment in EV infrastructure will put us on the road to a 100% clean transportation sector in North Carolina.

Sincerely,

renee Skudra
3806 Manor Drive
Greensboro, NC 27403
renees52@aol.com
(510) 277-7157

This message was sent by KnowWho, as a service provider only, on behalf of the individual noted in the sender information.

From: William Cline (wscline1@gmail.com) Sent You a Personal Message
To: [daq.NC_VWGrants](#)
Subject: [External] Use Volkswagen funds to electrify NC transportation
Date: Tuesday, December 05, 2017 9:50:41 PM

CAUTION: External email. Do not click links or open attachments unless verified. Send all suspicious email as an attachment to report.spam@nc.gov.

Dear Division of Air Quality,

I am writing to urge DEQ to wisely invest the \$92 million in Volkswagen settlement funds in electric vehicles and infrastructure. Taking advantage of these funds to jumpstart the electrification of North Carolina's transportation sector will mean less money sent out of state for petroleum, more in-state jobs, and cleaner air.

Specifically, I recommend that DEQ allocate the maximum allowable amount (15%) of the funds for electric vehicle charging infrastructure and installations. And I encourage DEQ to prioritize electric vehicles and buses for replacement whenever possible with the other 85% of the settlement funds. Doing so will maximize the local economic impact and the reduction of air pollution.

I encourage you to not use the funding for natural gas, propane or diesel vehicles. Further dependence on fossil fuels means more pollution. Only a transition to electric vehicles and investment in EV infrastructure will put us on the road to a 100% clean transportation sector in North Carolina.

Sincerely,

William Cline
2924 Oberlin Rd
Raleigh, NC 27608
wscline1@gmail.com
(919) 452-0832

This message was sent by KnowWho, as a service provider only, on behalf of the individual noted in the sender information.

From: STEVEN MCCRAW (smmccraw@gmail.com) Sent You a Personal Message
To: [daq.NC_VWGrants](#)
Subject: [External] Use Volkswagen funds to electrify NC transportation
Date: Tuesday, December 05, 2017 9:49:59 PM

CAUTION: External email. Do not click links or open attachments unless verified. Send all suspicious email as an attachment to report.spam@nc.gov.

Dear Division of Air Quality,

I am writing to urge DEQ to wisely invest the \$92 million in Volkswagen settlement funds in electric vehicles and infrastructure. Taking advantage of these funds to jumpstart the electrification of North Carolina's transportation sector will mean less money sent out of state for petroleum, more in-state jobs, and cleaner air.

Specifically, I recommend that DEQ allocate the maximum allowable amount (15%) of the funds for electric vehicle charging infrastructure and installations. And I encourage DEQ to prioritize electric vehicles and buses for replacement whenever possible with the other 85% of the settlement funds. Doing so will maximize the local economic impact and the reduction of air pollution.

I encourage you to not use the funding for natural gas, propane or diesel vehicles. Further dependence on fossil fuels means more pollution. Only a transition to electric vehicles and investment in EV infrastructure will put us on the road to a 100% clean transportation sector in North Carolina.

Sincerely,

STEVEN MCCRAW
4 Mitchell Ave
STEVEN, NC 28806
smmccraw@gmail.com
(919) 264-7970

This message was sent by KnowWho, as a service provider only, on behalf of the individual noted in the sender information.

From: Dan Clere (danielclere@gmail.com) Sent You a Personal Message
To: [daq.NC_VWGrants](#)
Subject: [External] Use Volkswagen funds to electrify NC transportation
Date: Tuesday, December 05, 2017 9:49:16 PM

CAUTION: External email. Do not click links or open attachments unless verified. Send all suspicious email as an attachment to report.spam@nc.gov.

Dear Division of Air Quality,

I am writing to urge DEQ to wisely invest the \$92 million in Volkswagen settlement funds in electric vehicles and infrastructure. Taking advantage of these funds to jumpstart the electrification of North Carolina's transportation sector will mean less money sent out of state for petroleum, more in-state jobs, and cleaner air.

Specifically, I recommend that DEQ allocate the maximum allowable amount (15%) of the funds for electric vehicle charging infrastructure and installations. And I encourage DEQ to prioritize electric vehicles and buses for replacement whenever possible with the other 85% of the settlement funds. Doing so will maximize the local economic impact and the reduction of air pollution.

I encourage you to not use the funding for natural gas, propane or diesel vehicles. Further dependence on fossil fuels means more pollution. Only a transition to electric vehicles and investment in EV infrastructure will put us on the road to a 100% clean transportation sector in North Carolina.

Sincerely,

Dan Clere
232 Bent Creek Ranch Rd.
Asheville, NC 28806
danielclere@gmail.com
(828) 712-5424

This message was sent by KnowWho, as a service provider only, on behalf of the individual noted in the sender information.

From: Bill Dinsdale (bcdskd@atmc.net) Sent You a Personal Message
To: [daq.NC_VWGrants](#)
Subject: [External] Use Volkswagen funds to electrify NC transportation
Date: Tuesday, December 05, 2017 9:49:16 PM

CAUTION: External email. Do not click links or open attachments unless verified. Send all suspicious email as an attachment to report.spam@nc.gov.

Dear Division of Air Quality,

I am writing to urge DEQ to wisely invest the \$92 million in Volkswagen settlement funds in electric vehicles and infrastructure. Taking advantage of these funds to jumpstart the electrification of North Carolina's transportation sector will mean less money sent out of state for petroleum, more in-state jobs, and cleaner air.

Specifically, I recommend that DEQ allocate the maximum allowable amount (15%) of the funds for electric vehicle charging infrastructure and installations. And I encourage DEQ to prioritize electric vehicles and buses for replacement whenever possible with the other 85% of the settlement funds. Doing so will maximize the local economic impact and the reduction of air pollution.

I encourage you to not use the funding for natural gas, propane or diesel vehicles. Further dependence on fossil fuels means more pollution. Only a transition to electric vehicles and investment in EV infrastructure will put us on the road to a 100% clean transportation sector in North Carolina.

Sincerely,

Bill Dinsdale
2960 Irwin DR SE
Southport, NC 28461
bcdskd@atmc.net
(910) 253-4064

This message was sent by KnowWho, as a service provider only, on behalf of the individual noted in the sender information.

From: Anna Geyer (annageyer@gmail.com) Sent You a Personal Message
To: [daq.NC_VWGrants](#)
Subject: [External] Use Volkswagen funds to electrify NC transportation
Date: Tuesday, December 05, 2017 9:39:55 PM

CAUTION: External email. Do not click links or open attachments unless verified. Send all suspicious email as an attachment to report.spam@nc.gov.

Dear Division of Air Quality,

I am writing to urge DEQ to wisely invest the \$92 million in Volkswagen settlement funds in electric vehicles and infrastructure. Taking advantage of these funds to jumpstart the electrification of North Carolina's transportation sector will mean less money sent out of state for petroleum, more in-state jobs, and cleaner air.

Specifically, I recommend that DEQ allocate the maximum allowable amount (15%) of the funds for electric vehicle charging infrastructure and installations. And I encourage DEQ to prioritize electric vehicles and buses for replacement whenever possible with the other 85% of the settlement funds. Doing so will maximize the local economic impact and the reduction of air pollution.

I encourage you to not use the funding for natural gas, propane or diesel vehicles. Further dependence on fossil fuels means more pollution. Only a transition to electric vehicles and investment in EV infrastructure will put us on the road to a 100% clean transportation sector in North Carolina.

Sincerely,

Anna Geyer
4506 Ryan Street
Durham, NC 27704
annageyer@gmail.com
(919) 450-7268

This message was sent by KnowWho, as a service provider only, on behalf of the individual noted in the sender information.

From: Dan Faris (danffaris@aol.com) Sent You a Personal Message
To: [daq.NC_VWGrants](#)
Subject: [External] Use Volkswagen funds to electrify NC transportation
Date: Tuesday, December 05, 2017 9:35:08 PM

CAUTION: External email. Do not click links or open attachments unless verified. Send all suspicious email as an attachment to report.spam@nc.gov.

Dear Division of Air Quality,

I am writing to urge DEQ to wisely invest the \$92 million in Volkswagen settlement funds in electric vehicles and infrastructure. Taking advantage of these funds to jumpstart the electrification of North Carolina's transportation sector will mean less money sent out of state for petroleum, more in-state jobs, and cleaner air.

Specifically, I recommend that DEQ allocate the maximum allowable amount (15%) of the funds for electric vehicle charging infrastructure and installations. And I encourage DEQ to prioritize electric vehicles and buses for replacement whenever possible with the other 85% of the settlement funds. Doing so will maximize the local economic impact and the reduction of air pollution.

I encourage you to not use the funding for natural gas, propane or diesel vehicles. Further dependence on fossil fuels means more pollution. Only a transition to electric vehicles and investment in EV infrastructure will put us on the road to a 100% clean transportation sector in North Carolina.

Sincerely,

Dan Faris
6000 Rose Valley Dr.
Charlotte, NC 28210
danffaris@aol.com
(704) 553-2334

This message was sent by KnowWho, as a service provider only, on behalf of the individual noted in the sender information.

From: G.W. Cheney (gwcheney@ymail.com) Sent You a Personal Message
To: [daq.NC_VWGrants](#)
Subject: [External] Use Volkswagen funds to electrify NC transportation
Date: Tuesday, December 05, 2017 9:30:24 PM

CAUTION: External email. Do not click links or open attachments unless verified. Send all suspicious email as an attachment to report.spam@nc.gov.

Dear Division of Air Quality,

I am writing to urge DEQ to wisely invest the \$92 million in Volkswagen settlement funds in electric vehicles and infrastructure. Taking advantage of these funds to jumpstart the electrification of North Carolina's transportation sector will mean less money sent out of state for petroleum, more in-state jobs, and cleaner air.

Specifically, I recommend that DEQ allocate the maximum allowable amount (15%) of the funds for electric vehicle charging infrastructure and installations. And I encourage DEQ to prioritize electric vehicles and buses for replacement whenever possible with the other 85% of the settlement funds. Doing so will maximize the local economic impact and the reduction of air pollution.

I encourage you to not use the funding for natural gas, propane or diesel vehicles. Further dependence on fossil fuels means more pollution. Only a transition to electric vehicles and investment in EV infrastructure will put us on the road to a 100% clean transportation sector in North Carolina.

Sincerely,

G.W. Cheney
315 Hickory Lane
G.W., NC 28607
gwcheney@ymail.com
(828) 773-4120

This message was sent by KnowWho, as a service provider only, on behalf of the individual noted in the sender information.

From: Jen East (swxe@hotmail.com) Sent You a Personal Message
To: [daq.NC_VWGrants](#)
Subject: [External] Use Volkswagen funds to electrify NC transportation
Date: Tuesday, December 05, 2017 9:30:01 PM

CAUTION: External email. Do not click links or open attachments unless verified. Send all suspicious email as an attachment to report.spam@nc.gov.

Dear Division of Air Quality,

I am writing to urge DEQ to wisely invest the \$92 million in Volkswagen settlement funds in electric vehicles and infrastructure. Taking advantage of these funds to jumpstart the electrification of North Carolina's transportation sector will mean less money sent out of state for petroleum, more in-state jobs, and cleaner air.

Specifically, I recommend that DEQ allocate the maximum allowable amount (15%) of the funds for electric vehicle charging infrastructure and installations. And I encourage DEQ to prioritize electric vehicles and buses for replacement whenever possible with the other 85% of the settlement funds. Doing so will maximize the local economic impact and the reduction of air pollution.

I encourage you to not use the funding for natural gas, propane or diesel vehicles. Further dependence on fossil fuels means more pollution. Only a transition to electric vehicles and investment in EV infrastructure will put us on the road to a 100% clean transportation sector in North Carolina.

Sincerely,

Jen East
1805 US 70 W
Marion, NC 28752
swxe@hotmail.com
(828) 527-1096

This message was sent by KnowWho, as a service provider only, on behalf of the individual noted in the sender information.

From: Johnny Mayall (peglegpete@gmail.com) Sent You a Personal Message
To: [daq.NC_VWGrants](#)
Subject: [External] Use Volkswagen funds to electrify NC transportation
Date: Tuesday, December 05, 2017 9:26:24 PM

CAUTION: External email. Do not click links or open attachments unless verified. Send all suspicious email as an attachment to report.spam@nc.gov.

Dear Division of Air Quality,

I am writing to urge DEQ to wisely invest the \$92 million in Volkswagen settlement funds in electric vehicles and infrastructure. Taking advantage of these funds to jumpstart the electrification of North Carolina's transportation sector will mean less money sent out of state for petroleum, more in-state jobs, and cleaner air.

Specifically, I recommend that DEQ allocate the maximum allowable amount (15%) of the funds for electric vehicle charging infrastructure and installations. And I encourage DEQ to prioritize electric vehicles and buses for replacement whenever possible with the other 85% of the settlement funds. Doing so will maximize the local economic impact and the reduction of air pollution.

I encourage you to not use the funding for natural gas, propane or diesel vehicles. Further dependence on fossil fuels means more pollution. Only a transition to electric vehicles and investment in EV infrastructure will put us on the road to a 100% clean transportation sector in North Carolina.

Sincerely,

Johnny Mayall
86A Willow Way
Chapel Hill, NC 27516
peglegpete@gmail.com
(919) 391-9097

This message was sent by KnowWho, as a service provider only, on behalf of the individual noted in the sender information.

From: Richard George (regeorge58@yahoo.com) Sent You a Personal Message
To: [daq.NC_VWGrants](#)
Subject: [External] Use Volkswagen funds to electrify NC transportation
Date: Tuesday, December 05, 2017 9:23:43 PM

CAUTION: External email. Do not click links or open attachments unless verified. Send all suspicious email as an attachment to report.spam@nc.gov.

Dear Division of Air Quality,

I am writing to urge DEQ to wisely invest the \$92 million in Volkswagen settlement funds in electric vehicles and infrastructure. Taking advantage of these funds to jumpstart the electrification of North Carolina's transportation sector will mean less money sent out of state for petroleum, more in-state jobs, and cleaner air.

Specifically, I recommend that DEQ allocate the maximum allowable amount (15%) of the funds for electric vehicle charging infrastructure and installations. And I encourage DEQ to prioritize electric vehicles and buses for replacement whenever possible with the other 85% of the settlement funds. Doing so will maximize the local economic impact and the reduction of air pollution.

I encourage you to not use the funding for natural gas, propane or diesel vehicles. Further dependence on fossil fuels means more pollution. Only a transition to electric vehicles and investment in EV infrastructure will put us on the road to a 100% clean transportation sector in North Carolina.

Sincerely,

Richard George
5849 Greenway Vista Lane
Richard, NC 28216
regeorge58@yahoo.com
(980) 938-0952

This message was sent by KnowWho, as a service provider only, on behalf of the individual noted in the sender information.

From: Ruth Noble (ruth@nobleruth.com) Sent You a Personal Message
To: daq.NC_VWGrants
Subject: [External] Use Volkswagen funds to electrify NC transportation
Date: Tuesday, December 05, 2017 9:18:49 PM

CAUTION: External email. Do not click links or open attachments unless verified. Send all suspicious email as an attachment to report.spam@nc.gov.

Dear Division of Air Quality,

I am writing to urge DEQ to wisely invest the \$92 million in Volkswagen settlement funds in electric vehicles and infrastructure. Taking advantage of these funds to jumpstart the electrification of North Carolina's transportation sector will mean less money sent out of state for petroleum, more in-state jobs, and cleaner air.

Specifically, I recommend that DEQ allocate the maximum allowable amount (15%) of the funds for electric vehicle charging infrastructure and installations. And I encourage DEQ to prioritize electric vehicles and buses for replacement whenever possible with the other 85% of the settlement funds. Doing so will maximize the local economic impact and the reduction of air pollution.

I encourage you to not use the funding for natural gas, propane or diesel vehicles. Further dependence on fossil fuels means more pollution. Only a transition to electric vehicles and investment in EV infrastructure will put us on the road to a 100% clean transportation sector in North Carolina.

Sincerely,

Ruth Noble
26 Rylee Ridge
Asheville, NC 28805
ruth@nobleruth.com
(828) 299-9326

This message was sent by KnowWho, as a service provider only, on behalf of the individual noted in the sender information.

From: Gary Lavinder (lavindergary@gmail.com) Sent You a Personal Message
To: [daq.NC_VWGrants](#)
Subject: [External] Use Volkswagen funds to electrify NC transportation
Date: Tuesday, December 05, 2017 9:17:32 PM

CAUTION: External email. Do not click links or open attachments unless verified. Send all suspicious email as an attachment to report.spam@nc.gov.

Dear Division of Air Quality,

I am writing to urge DEQ to wisely invest the \$92 million in Volkswagen settlement funds in electric vehicles and infrastructure. Taking advantage of these funds to jumpstart the electrification of North Carolina's transportation sector will mean less money sent out of state for petroleum, more in-state jobs, and cleaner air.

Specifically, I recommend that DEQ allocate the maximum allowable amount (15%) of the funds for electric vehicle charging infrastructure and installations. And I encourage DEQ to prioritize electric vehicles and buses for replacement whenever possible with the other 85% of the settlement funds. Doing so will maximize the local economic impact and the reduction of air pollution.

I encourage you to not use the funding for natural gas, propane or diesel vehicles. Further dependence on fossil fuels means more pollution. Only a transition to electric vehicles and investment in EV infrastructure will put us on the road to a 100% clean transportation sector in North Carolina.

Sincerely,

Gary Lavinder
348 South Greenbriar Road
Statesville,, NC 28625
lavindergary@gmail.com
(704) 872-3492

This message was sent by KnowWho, as a service provider only, on behalf of the individual noted in the sender information.

From: thomas castle (tomtom440@yahoo.com) Sent You a Personal Message
To: [daq.NC_VWGrants](#)
Subject: [External] Use Volkswagen funds to electrify NC transportation
Date: Tuesday, December 05, 2017 9:06:29 PM

CAUTION: External email. Do not click links or open attachments unless verified. Send all suspicious email as an attachment to report.spam@nc.gov.

Dear Division of Air Quality,

I am writing to urge DEQ to wisely invest the \$92 million in Volkswagen settlement funds in electric vehicles and infrastructure. Taking advantage of these funds to jumpstart the electrification of North Carolina's transportation sector will mean less money sent out of state for petroleum, more in-state jobs, and cleaner air.

Specifically, I recommend that DEQ allocate the maximum allowable amount (15%) of the funds for electric vehicle charging infrastructure and installations. And I encourage DEQ to prioritize electric vehicles and buses for replacement whenever possible with the other 85% of the settlement funds. Doing so will maximize the local economic impact and the reduction of air pollution.

I encourage you to not use the funding for natural gas, propane or diesel vehicles. Further dependence on fossil fuels means more pollution. Only a transition to electric vehicles and investment in EV infrastructure will put us on the road to a 100% clean transportation sector in North Carolina.

Sincerely,

thomas castle
4297 abernathy circle
valdese, NC 28690
tomtom440@yahoo.com
(717) 623-5174

This message was sent by KnowWho, as a service provider only, on behalf of the individual noted in the sender information.

From: Deron Tse (dtse.breakbreadtogether@gmail.com) Sent You a Personal Message
To: [daq.NC_VWGrants](#)
Subject: [External] Use Volkswagen funds to electrify NC transportation
Date: Tuesday, December 05, 2017 9:04:43 PM

CAUTION: External email. Do not click links or open attachments unless verified. Send all suspicious email as an attachment to report.spam@nc.gov.

Dear Division of Air Quality,

I am writing to urge DEQ to wisely invest the \$92 million in Volkswagen settlement funds in electric vehicles and infrastructure. Taking advantage of these funds to jumpstart the electrification of North Carolina's transportation sector will mean less money sent out of state for petroleum, more in-state jobs, and cleaner air.

Specifically, I recommend that DEQ allocate the maximum allowable amount (15%) of the funds for electric vehicle charging infrastructure and installations. And I encourage DEQ to prioritize electric vehicles and buses for replacement whenever possible with the other 85% of the settlement funds. Doing so will maximize the local economic impact and the reduction of air pollution.

I encourage you to not use the funding for natural gas, propane or diesel vehicles. Further dependence on fossil fuels means more pollution. Only a transition to electric vehicles and investment in EV infrastructure will put us on the road to a 100% clean transportation sector in North Carolina.

Sincerely,

Deron Tse
6201 Daybrook Cir
Raleigh, NC 27606
dtse.breakbreadtogether@gmail.com
(919) 322-8301

This message was sent by KnowWho, as a service provider only, on behalf of the individual noted in the sender information.

From: ursula beaudry (ursiebear55@gmail.com) Sent You a Personal Message
To: [daq.NC_VWGrants](#)
Subject: [External] Use Volkswagen funds to electrify NC transportation
Date: Tuesday, December 05, 2017 9:04:36 PM

CAUTION: External email. Do not click links or open attachments unless verified. Send all suspicious email as an attachment to report.spam@nc.gov.

Dear Division of Air Quality,

I am writing to urge DEQ to wisely invest the \$92 million in Volkswagen settlement funds in electric vehicles and infrastructure. Taking advantage of these funds to jumpstart the electrification of North Carolina's transportation sector will mean less money sent out of state for petroleum, more in-state jobs, and cleaner air.

Specifically, I recommend that DEQ allocate the maximum allowable amount (15%) of the funds for electric vehicle charging infrastructure and installations. And I encourage DEQ to prioritize electric vehicles and buses for replacement whenever possible with the other 85% of the settlement funds. Doing so will maximize the local economic impact and the reduction of air pollution.

I encourage you to not use the funding for natural gas, propane or diesel vehicles. Further dependence on fossil fuels means more pollution. Only a transition to electric vehicles and investment in EV infrastructure will put us on the road to a 100% clean transportation sector in North Carolina.

Sincerely,

ursula beaudry
4297 abernathy circle
valdese, NC 28690
ursiebear55@gmail.com
(828) 874-0714

This message was sent by KnowWho, as a service provider only, on behalf of the individual noted in the sender information.

From: Linda Bloom (suellen.bloom@gmail.com) Sent You a Personal Message
To: [daq.NC_VWGrants](#)
Subject: [External] Use Volkswagen funds to electrify NC transportation
Date: Tuesday, December 05, 2017 9:00:32 PM

CAUTION: External email. Do not click links or open attachments unless verified. Send all suspicious email as an attachment to report.spam@nc.gov.

Dear Division of Air Quality,

I am writing to urge DEQ to wisely invest the \$92 million in Volkswagen settlement funds in electric vehicles and infrastructure. Taking advantage of these funds to jumpstart the electrification of North Carolina's transportation sector will mean less money sent out of state for petroleum, more in-state jobs, and cleaner air.

Specifically, I recommend that DEQ allocate the maximum allowable amount (15%) of the funds for electric vehicle charging infrastructure and installations. And I encourage DEQ to prioritize electric vehicles and buses for replacement whenever possible with the other 85% of the settlement funds. Doing so will maximize the local economic impact and the reduction of air pollution.

I encourage you to not use the funding for natural gas, propane or diesel vehicles. Further dependence on fossil fuels means more pollution. Only a transition to electric vehicles and investment in EV infrastructure will put us on the road to a 100% clean transportation sector in North Carolina.

Sincerely,

Linda Bloom
527 yeopim rd edenton NC 27932-9412 United States
edenton, NC 27932
suellen.bloom@gmail.com
(242) 333-0626

This message was sent by KnowWho, as a service provider only, on behalf of the individual noted in the sender information.

From: Susan Broadhead (s_broadhead@hotmail.com) Sent You a Personal Message
To: [daq.NC_VWGrants](#)
Subject: [External] Use Volkswagen funds to electrify NC transportation
Date: Tuesday, December 05, 2017 8:57:38 PM

CAUTION: External email. Do not click links or open attachments unless verified. Send all suspicious email as an attachment to report.spam@nc.gov.

Dear Division of Air Quality,

I am writing to urge DEQ to wisely invest the \$92 million in Volkswagen settlement funds in electric vehicles and infrastructure. Taking advantage of these funds to jumpstart the electrification of North Carolina's transportation sector will mean less money sent out of state for petroleum, more in-state jobs, and cleaner air.

Specifically, I recommend that DEQ allocate the maximum allowable amount (15%) of the funds for electric vehicle charging infrastructure and installations. And I encourage DEQ to prioritize electric vehicles and buses for replacement whenever possible with the other 85% of the settlement funds. Doing so will maximize the local economic impact and the reduction of air pollution.

I encourage you to not use the funding for natural gas, propane or diesel vehicles. Further dependence on fossil fuels means more pollution. Only a transition to electric vehicles and investment in EV infrastructure will put us on the road to a 100% clean transportation sector in North Carolina.

Sincerely,

Susan Broadhead
48 Full Circle Trail
Black Mountain, NC 28711
s_broadhead@hotmail.com
(828) 669-1785

This message was sent by KnowWho, as a service provider only, on behalf of the individual noted in the sender information.

From: William Snyder (whs@nc.rr.com) Sent You a Personal Message
To: [daq.NC_VWGrants](#)
Subject: [External] Use Volkswagen funds to electrify NC transportation
Date: Tuesday, December 05, 2017 8:57:02 PM

CAUTION: External email. Do not click links or open attachments unless verified. Send all suspicious email as an attachment to report.spam@nc.gov.

Dear Division of Air Quality,

I am writing to urge DEQ to wisely invest the \$92 million in Volkswagen settlement funds in electric vehicles and infrastructure. Taking advantage of these funds to jumpstart the electrification of North Carolina's transportation sector will mean less money sent out of state for petroleum, more in-state jobs, and cleaner air.

Specifically, I recommend that DEQ allocate the maximum allowable amount (15%) of the funds for electric vehicle charging infrastructure and installations. And I encourage DEQ to prioritize electric vehicles and buses for replacement whenever possible with the other 85% of the settlement funds. Doing so will maximize the local economic impact and the reduction of air pollution.

I encourage you to not use the funding for natural gas, propane or diesel vehicles. Further dependence on fossil fuels means more pollution. Only a transition to electric vehicles and investment in EV infrastructure will put us on the road to a 100% clean transportation sector in North Carolina.

Sincerely,

William Snyder
7312 Grist Mill Road
Raleigh, NC 27615
whs@nc.rr.com
(919) 848-0899

This message was sent by KnowWho, as a service provider only, on behalf of the individual noted in the sender information.

From: Lorraine Cocomero (loricocomero@gmail.com) Sent You a Personal Message
To: [daq.NC_VWGrants](#)
Subject: [External] Use Volkswagen funds to electrify NC transportation
Date: Tuesday, December 05, 2017 8:56:45 PM

CAUTION: External email. Do not click links or open attachments unless verified. Send all suspicious email as an attachment to report.spam@nc.gov.

Dear Division of Air Quality,

I am writing to urge DEQ to wisely invest the \$92 million in Volkswagen settlement funds in electric vehicles and infrastructure. Taking advantage of these funds to jumpstart the electrification of North Carolina's transportation sector will mean less money sent out of state for petroleum, more in-state jobs, and cleaner air.

Specifically, I recommend that DEQ allocate the maximum allowable amount (15%) of the funds for electric vehicle charging infrastructure and installations. And I encourage DEQ to prioritize electric vehicles and buses for replacement whenever possible with the other 85% of the settlement funds. Doing so will maximize the local economic impact and the reduction of air pollution.

I encourage you to not use the funding for natural gas, propane or diesel vehicles. Further dependence on fossil fuels means more pollution. Only a transition to electric vehicles and investment in EV infrastructure will put us on the road to a 100% clean transportation sector in North Carolina.

Sincerely,

Lorraine Cocomero
P O Box 1177
Carrboro, NC 27510
loricocomero@gmail.com
(919) 960-9591

This message was sent by KnowWho, as a service provider only, on behalf of the individual noted in the sender information.

From: Gianna Krstic (giannaloveslife@gmail.com) Sent You a Personal Message
To: [daq.NC_VWGrants](#)
Subject: [External] Use Volkswagen funds to electrify NC transportation
Date: Tuesday, December 05, 2017 8:56:45 PM

CAUTION: External email. Do not click links or open attachments unless verified. Send all suspicious email as an attachment to report.spam@nc.gov.

Dear Division of Air Quality,

I am writing to urge DEQ to wisely invest the \$92 million in Volkswagen settlement funds in electric vehicles and infrastructure. Taking advantage of these funds to jumpstart the electrification of North Carolina's transportation sector will mean less money sent out of state for petroleum, more in-state jobs, and cleaner air.

Specifically, I recommend that DEQ allocate the maximum allowable amount (15%) of the funds for electric vehicle charging infrastructure and installations. And I encourage DEQ to prioritize electric vehicles and buses for replacement whenever possible with the other 85% of the settlement funds. Doing so will maximize the local economic impact and the reduction of air pollution.

I encourage you to not use the funding for natural gas, propane or diesel vehicles. Further dependence on fossil fuels means more pollution. Only a transition to electric vehicles and investment in EV infrastructure will put us on the road to a 100% clean transportation sector in North Carolina.

Sincerely,

Gianna Krstic
1117 Minnie Dr
Raleigh, NC 27603
giannaloveslife@gmail.com
(305) 799-2381

This message was sent by KnowWho, as a service provider only, on behalf of the individual noted in the sender information.

From: Sean McGlynn (seandmcglynn@gmail.com) Sent You a Personal Message
To: [daq.NC_VWGrants](#)
Subject: [External] Use Volkswagen funds to electrify NC transportation
Date: Tuesday, December 05, 2017 8:56:17 PM

CAUTION: External email. Do not click links or open attachments unless verified. Send all suspicious email as an attachment to report.spam@nc.gov.

Dear Division of Air Quality,

I am writing to urge DEQ to wisely invest the \$92 million in Volkswagen settlement funds in electric vehicles and infrastructure. Taking advantage of these funds to jumpstart the electrification of North Carolina's transportation sector will mean less money sent out of state for petroleum, more in-state jobs, and cleaner air.

Specifically, I recommend that DEQ allocate the maximum allowable amount (15%) of the funds for electric vehicle charging infrastructure and installations. And I encourage DEQ to prioritize electric vehicles and buses for replacement whenever possible with the other 85% of the settlement funds. Doing so will maximize the local economic impact and the reduction of air pollution.

I encourage you to not use the funding for natural gas, propane or diesel vehicles. Further dependence on fossil fuels means more pollution. Only a transition to electric vehicles and investment in EV infrastructure will put us on the road to a 100% clean transportation sector in North Carolina.

Sincerely,

Sean McGlynn
1330 W 1st St Apt C
Winston Salem, NC 27101
seandmcglynn@gmail.com
(336) 995-5392

This message was sent by KnowWho, as a service provider only, on behalf of the individual noted in the sender information.

From: Peter Schubert (schubyps@gmail.com) Sent You a Personal Message
To: [daq.NC_VWGrants](#)
Subject: [External] Use Volkswagen funds to electrify NC transportation
Date: Tuesday, December 05, 2017 8:56:16 PM

CAUTION: External email. Do not click links or open attachments unless verified. Send all suspicious email as an attachment to report.spam@nc.gov.

Dear Division of Air Quality,

I am writing to urge DEQ to wisely invest the \$92 million in Volkswagen settlement funds in electric vehicles and infrastructure. Taking advantage of these funds to jumpstart the electrification of North Carolina's transportation sector will mean less money sent out of state for petroleum, more in-state jobs, and cleaner air.

Specifically, I recommend that DEQ allocate the maximum allowable amount (15%) of the funds for electric vehicle charging infrastructure and installations. And I encourage DEQ to prioritize electric vehicles and buses for replacement whenever possible with the other 85% of the settlement funds. Doing so will maximize the local economic impact and the reduction of air pollution.

I encourage you to not use the funding for natural gas, propane or diesel vehicles. Further dependence on fossil fuels means more pollution. Only a transition to electric vehicles and investment in EV infrastructure will put us on the road to a 100% clean transportation sector in North Carolina.

Sincerely,

Peter Schubert
927 Bluestone Rd
Durham, NC 27713
schubyps@gmail.com
(919) 544-4923

This message was sent by KnowWho, as a service provider only, on behalf of the individual noted in the sender information.

From: Gianna Krstic (giannaloveslife@gmail.com) Sent You a Personal Message
To: [daq.NC_VWGrants](#)
Subject: [External] Use Volkswagen funds to electrify NC transportation
Date: Tuesday, December 05, 2017 8:55:37 PM

CAUTION: External email. Do not click links or open attachments unless verified. Send all suspicious email as an attachment to report.spam@nc.gov.

Dear Division of Air Quality,

I am writing to urge DEQ to wisely invest the \$92 million in Volkswagen settlement funds in electric vehicles and infrastructure. Taking advantage of these funds to jumpstart the electrification of North Carolina's transportation sector will mean less money sent out of state for petroleum, more in-state jobs, and cleaner air.

Specifically, I recommend that DEQ allocate the maximum allowable amount (15%) of the funds for electric vehicle charging infrastructure and installations. And I encourage DEQ to prioritize electric vehicles and buses for replacement whenever possible with the other 85% of the settlement funds. Doing so will maximize the local economic impact and the reduction of air pollution.

I encourage you to not use the funding for natural gas, propane or diesel vehicles. Further dependence on fossil fuels means more pollution. Only a transition to electric vehicles and investment in EV infrastructure will put us on the road to a 100% clean transportation sector in North Carolina.

Sincerely,

Gianna Krstic
188 Ocean Drive
Gianna, FL 33070
giannaloveslife@gmail.com
(305) 799-2381

This message was sent by KnowWho, as a service provider only, on behalf of the individual noted in the sender information.

From: Jarred Worley (pureunfiltered@yahoo.com) Sent You a Personal Message
To: [daq.NC_VWGrants](#)
Subject: [External] Use Volkswagen funds to electrify NC transportation
Date: Tuesday, December 05, 2017 8:54:17 PM

CAUTION: External email. Do not click links or open attachments unless verified. Send all suspicious email as an attachment to report.spam@nc.gov.

Dear Division of Air Quality,

I am writing to urge DEQ to wisely invest the \$92 million in Volkswagen settlement funds in electric vehicles and infrastructure. Taking advantage of these funds to jumpstart the electrification of North Carolina's transportation sector will mean less money sent out of state for petroleum, more in-state jobs, and cleaner air.

Specifically, I recommend that DEQ allocate the maximum allowable amount (15%) of the funds for electric vehicle charging infrastructure and installations. And I encourage DEQ to prioritize electric vehicles and buses for replacement whenever possible with the other 85% of the settlement funds. Doing so will maximize the local economic impact and the reduction of air pollution.

I encourage you to not use the funding for natural gas, propane or diesel vehicles. Further dependence on fossil fuels means more pollution. Only a transition to electric vehicles and investment in EV infrastructure will put us on the road to a 100% clean transportation sector in North Carolina.

Sincerely,

Jarred Worley
72 Ivy Overlook Drive
Marshall, NC 28753
pureunfiltered@yahoo.com
(828) 380-1041

This message was sent by KnowWho, as a service provider only, on behalf of the individual noted in the sender information.

From: Kinsey Nelson (browneyedkins@gmail.com) Sent You a Personal Message
To: [daq.NC_VWGrants](#)
Subject: [External] Use Volkswagen funds to electrify NC transportation
Date: Tuesday, December 05, 2017 8:51:47 PM

CAUTION: External email. Do not click links or open attachments unless verified. Send all suspicious email as an attachment to report.spam@nc.gov.

Dear Division of Air Quality,

I am writing to urge DEQ to wisely invest the \$92 million in Volkswagen settlement funds in electric vehicles and infrastructure. Taking advantage of these funds to jumpstart the electrification of North Carolina's transportation sector will mean less money sent out of state for petroleum, more in-state jobs, and cleaner air.

Specifically, I recommend that DEQ allocate the maximum allowable amount (15%) of the funds for electric vehicle charging infrastructure and installations. And I encourage DEQ to prioritize electric vehicles and buses for replacement whenever possible with the other 85% of the settlement funds. Doing so will maximize the local economic impact and the reduction of air pollution.

I encourage you to not use the funding for natural gas, propane or diesel vehicles. Further dependence on fossil fuels means more pollution. Only a transition to electric vehicles and investment in EV infrastructure will put us on the road to a 100% clean transportation sector in North Carolina.

Sincerely,

Kinsey Nelson
314 Tern Ct
Kill Devil Hills, NC 27948
browneyedkins@gmail.com
(252) 256-2923

This message was sent by KnowWho, as a service provider only, on behalf of the individual noted in the sender information.

From: Cashin Hunt (cashinhunt@gmail.com) Sent You a Personal Message
To: [daq.NC_VWGrants](#)
Subject: [External] Use Volkswagen funds to electrify NC transportation
Date: Tuesday, December 05, 2017 8:49:11 PM

CAUTION: External email. Do not click links or open attachments unless verified. Send all suspicious email as an attachment to report.spam@nc.gov.

Dear Division of Air Quality,

I am writing to urge DEQ to wisely invest the \$92 million in Volkswagen settlement funds in electric vehicles and infrastructure. Taking advantage of these funds to jumpstart the electrification of North Carolina's transportation sector will mean less money sent out of state for petroleum, more in-state jobs, and cleaner air.

Specifically, I recommend that DEQ allocate the maximum allowable amount (15%) of the funds for electric vehicle charging infrastructure and installations. And I encourage DEQ to prioritize electric vehicles and buses for replacement whenever possible with the other 85% of the settlement funds. Doing so will maximize the local economic impact and the reduction of air pollution.

I encourage you to not use the funding for natural gas, propane or diesel vehicles. Further dependence on fossil fuels means more pollution. Only a transition to electric vehicles and investment in EV infrastructure will put us on the road to a 100% clean transportation sector in North Carolina.

Sincerely,

Cashin Hunt
2333 Rosewood Ave
Winston Salem, NC 27103
cashinhunt@gmail.com
(336) 354-8548

This message was sent by KnowWho, as a service provider only, on behalf of the individual noted in the sender information.

From: Mary Lindsey (rossiel41@gmail.com) Sent You a Personal Message
To: [daq.NC_VWGrants](#)
Subject: [External] Use Volkswagen funds to electrify NC transportation
Date: Tuesday, December 05, 2017 8:47:39 PM

CAUTION: External email. Do not click links or open attachments unless verified. Send all suspicious email as an attachment to report.spam@nc.gov.

Dear Division of Air Quality,

I am writing to urge DEQ to wisely invest the \$92 million in Volkswagen settlement funds in electric vehicles and infrastructure. Taking advantage of these funds to jumpstart the electrification of North Carolina's transportation sector will mean less money sent out of state for petroleum, more in-state jobs, and cleaner air.

Specifically, I recommend that DEQ allocate the maximum allowable amount (15%) of the funds for electric vehicle charging infrastructure and installations. And I encourage DEQ to prioritize electric vehicles and buses for replacement whenever possible with the other 85% of the settlement funds. Doing so will maximize the local economic impact and the reduction of air pollution.

I encourage you to not use the funding for natural gas, propane or diesel vehicles. Further dependence on fossil fuels means more pollution. Only a transition to electric vehicles and investment in EV infrastructure will put us on the road to a 100% clean transportation sector in North Carolina.

Sincerely,

Mary Lindsey
3000 Galloway Ridge E209
Pittsboro, NC 27312
rossiel41@gmail.com
(919) 542-3281

This message was sent by KnowWho, as a service provider only, on behalf of the individual noted in the sender information.

From: Dana Lucas (dalucas@gmail.com) Sent You a Personal Message
To: [daq.NC_VWGrants](#)
Subject: [External] Use Volkswagen funds to electrify NC transportation
Date: Tuesday, December 05, 2017 8:41:54 PM

CAUTION: External email. Do not click links or open attachments unless verified. Send all suspicious email as an attachment to report.spam@nc.gov.

Dear Division of Air Quality,

I am writing to urge DEQ to wisely invest the \$92 million in Volkswagen settlement funds in electric vehicles and infrastructure. Taking advantage of these funds to jumpstart the electrification of North Carolina's transportation sector will mean less money sent out of state for petroleum, more in-state jobs, and cleaner air.

Specifically, I recommend that DEQ allocate the maximum allowable amount (15%) of the funds for electric vehicle charging infrastructure and installations. And I encourage DEQ to prioritize electric vehicles and buses for replacement whenever possible with the other 85% of the settlement funds. Doing so will maximize the local economic impact and the reduction of air pollution.

I encourage you to not use the funding for natural gas, propane or diesel vehicles. Further dependence on fossil fuels means more pollution. Only a transition to electric vehicles and investment in EV infrastructure will put us on the road to a 100% clean transportation sector in North Carolina.

Sincerely,

Dana Lucas
11920 Joleen Ct., Apt. 315
Huntersville, NC 28078
dalucas@gmail.com
(704) 293-3328

This message was sent by KnowWho, as a service provider only, on behalf of the individual noted in the sender information.

From: Jann Boggs (jaspalding@juno.com) Sent You a Personal Message
To: [daq.NC_VWGrants](#)
Subject: [External] Use Volkswagen funds to electrify NC transportation
Date: Tuesday, December 05, 2017 8:40:59 PM

CAUTION: External email. Do not click links or open attachments unless verified. Send all suspicious email as an attachment to report.spam@nc.gov.

Dear Division of Air Quality,

I am writing to urge DEQ to wisely invest the \$92 million in Volkswagen settlement funds in electric vehicles and infrastructure. Taking advantage of these funds to jumpstart the electrification of North Carolina's transportation sector will mean less money sent out of state for petroleum, more in-state jobs, and cleaner air.

Specifically, I recommend that DEQ allocate the maximum allowable amount (15%) of the funds for electric vehicle charging infrastructure and installations. And I encourage DEQ to prioritize electric vehicles and buses for replacement whenever possible with the other 85% of the settlement funds. Doing so will maximize the local economic impact and the reduction of air pollution.

I encourage you to not use the funding for natural gas, propane or diesel vehicles. Further dependence on fossil fuels means more pollution. Only a transition to electric vehicles and investment in EV infrastructure will put us on the road to a 100% clean transportation sector in North Carolina.

Sincerely,

Jann Boggs
PO Box 1942
Sparta, NC 28675
jaspalding@juno.com
(727) 641-4925

This message was sent by KnowWho, as a service provider only, on behalf of the individual noted in the sender information.

From: Claudia Kaplan (kaplans@nc.rr.com) Sent You a Personal Message
To: [daq.NC_VWGrants](#)
Subject: [External] Use Volkswagen funds to electrify NC transportation
Date: Tuesday, December 05, 2017 8:39:56 PM

CAUTION: External email. Do not click links or open attachments unless verified. Send all suspicious email as an attachment to report.spam@nc.gov.

Dear Division of Air Quality,

I am writing to urge DEQ to wisely invest the \$92 million in Volkswagen settlement funds in electric vehicles and infrastructure. Taking advantage of these funds to jumpstart the electrification of North Carolina's transportation sector will mean less money sent out of state for petroleum, more in-state jobs, and cleaner air.

Specifically, I recommend that DEQ allocate the maximum allowable amount (15%) of the funds for electric vehicle charging infrastructure and installations. And I encourage DEQ to prioritize electric vehicles and buses for replacement whenever possible with the other 85% of the settlement funds. Doing so will maximize the local economic impact and the reduction of air pollution.

I encourage you to not use the funding for natural gas, propane or diesel vehicles. Further dependence on fossil fuels means more pollution. Only a transition to electric vehicles and investment in EV infrastructure will put us on the road to a 100% clean transportation sector in North Carolina.

Sincerely,

Claudia Kaplan
4911 Victoria Dr.
Durham, NC 27713
kaplans@nc.rr.com
(919) 932-9635

This message was sent by KnowWho, as a service provider only, on behalf of the individual noted in the sender information.

From: Michelle Yates (myates67@gmail.com) Sent You a Personal Message
To: [daq.NC_VWGrants](#)
Subject: [External] Use Volkswagen funds to electrify NC transportation
Date: Tuesday, December 05, 2017 8:36:23 PM

CAUTION: External email. Do not click links or open attachments unless verified. Send all suspicious email as an attachment to report.spam@nc.gov.

Dear Division of Air Quality,

I am writing to urge DEQ to wisely invest the \$92 million in Volkswagen settlement funds in electric vehicles and infrastructure. Taking advantage of these funds to jumpstart the electrification of North Carolina's transportation sector will mean less money sent out of state for petroleum, more in-state jobs, and cleaner air.

Specifically, I recommend that DEQ allocate the maximum allowable amount (15%) of the funds for electric vehicle charging infrastructure and installations. And I encourage DEQ to prioritize electric vehicles and buses for replacement whenever possible with the other 85% of the settlement funds. Doing so will maximize the local economic impact and the reduction of air pollution.

I encourage you to not use the funding for natural gas, propane or diesel vehicles. Further dependence on fossil fuels means more pollution. Only a transition to electric vehicles and investment in EV infrastructure will put us on the road to a 100% clean transportation sector in North Carolina.

Sincerely,

Michelle Yates
206 E Jules Verne Way
Cary, NC 27511
myates67@gmail.com
(919) 616-2791

This message was sent by KnowWho, as a service provider only, on behalf of the individual noted in the sender information.

From: Jacob Yow (yow-j@hotmail.com) Sent You a Personal Message
To: [daq.NC_VWGrants](#)
Subject: [External] Use Volkswagen funds to electrify NC transportation
Date: Tuesday, December 05, 2017 8:36:21 PM

CAUTION: External email. Do not click links or open attachments unless verified. Send all suspicious email as an attachment to report.spam@nc.gov.

Dear Division of Air Quality,

I am writing to urge DEQ to wisely invest the \$92 million in Volkswagen settlement funds in electric vehicles and infrastructure. Taking advantage of these funds to jumpstart the electrification of North Carolina's transportation sector will mean less money sent out of state for petroleum, more in-state jobs, and cleaner air.

Specifically, I recommend that DEQ allocate the maximum allowable amount (15%) of the funds for electric vehicle charging infrastructure and installations. And I encourage DEQ to prioritize electric vehicles and buses for replacement whenever possible with the other 85% of the settlement funds. Doing so will maximize the local economic impact and the reduction of air pollution.

I encourage you to not use the funding for natural gas, propane or diesel vehicles. Further dependence on fossil fuels means more pollution. Only a transition to electric vehicles and investment in EV infrastructure will put us on the road to a 100% clean transportation sector in North Carolina.

Sincerely,

Jacob Yow
2300 East 4th St
Greenville, NC 27858
yow-j@hotmail.com
(336) 974-1014

This message was sent by KnowWho, as a service provider only, on behalf of the individual noted in the sender information.

From: Mary Pagano (mzp396@aol.com) Sent You a Personal Message
To: [daq.NC_VWGrants](#)
Subject: [External] Use Volkswagen funds to electrify NC transportation
Date: Tuesday, December 05, 2017 8:34:43 PM

CAUTION: External email. Do not click links or open attachments unless verified. Send all suspicious email as an attachment to report.spam@nc.gov.

Dear Division of Air Quality,

I am writing to urge DEQ to wisely invest the \$92 million in Volkswagen settlement funds in electric vehicles and infrastructure. Taking advantage of these funds to jumpstart the electrification of North Carolina's transportation sector will mean less money sent out of state for petroleum, more in-state jobs, and cleaner air.

Specifically, I recommend that DEQ allocate the maximum allowable amount (15%) of the funds for electric vehicle charging infrastructure and installations. And I encourage DEQ to prioritize electric vehicles and buses for replacement whenever possible with the other 85% of the settlement funds. Doing so will maximize the local economic impact and the reduction of air pollution.

I encourage you to not use the funding for natural gas, propane or diesel vehicles. Further dependence on fossil fuels means more pollution. Only a transition to electric vehicles and investment in EV infrastructure will put us on the road to a 100% clean transportation sector in North Carolina.

Sincerely,

Mary Pagano
981 7 Lks N
West End, NC 27376
mzp396@aol.com
(910) 400-5318

This message was sent by KnowWho, as a service provider only, on behalf of the individual noted in the sender information.

From: Janine Lafferty (jayla284@hotmail.com) Sent You a Personal Message
To: [daq.NC_VWGrants](#)
Subject: [External] Use Volkswagen funds to electrify NC transportation
Date: Tuesday, December 05, 2017 8:33:46 PM

CAUTION: External email. Do not click links or open attachments unless verified. Send all suspicious email as an attachment to report.spam@nc.gov.

Dear Division of Air Quality,

I am writing to urge DEQ to wisely invest the \$92 million in Volkswagen settlement funds in electric vehicles and infrastructure. Taking advantage of these funds to jumpstart the electrification of North Carolina's transportation sector will mean less money sent out of state for petroleum, more in-state jobs, and cleaner air.

Specifically, I recommend that DEQ allocate the maximum allowable amount (15%) of the funds for electric vehicle charging infrastructure and installations. And I encourage DEQ to prioritize electric vehicles and buses for replacement whenever possible with the other 85% of the settlement funds. Doing so will maximize the local economic impact and the reduction of air pollution.

I encourage you to not use the funding for natural gas, propane or diesel vehicles. Further dependence on fossil fuels means more pollution. Only a transition to electric vehicles and investment in EV infrastructure will put us on the road to a 100% clean transportation sector in North Carolina.

Sincerely,

Janine Lafferty
6614 Glenlivet Court
Charlotte, NC 28278
jayla284@hotmail.com
(704) 588-7708

This message was sent by KnowWho, as a service provider only, on behalf of the individual noted in the sender information.

From: Gordon Barber (resonus@gmail.com) Sent You a Personal Message
To: [daq.NC_VWGrants](#)
Subject: [External] Use Volkswagen funds to electrify NC transportation
Date: Tuesday, December 05, 2017 8:33:11 PM

CAUTION: External email. Do not click links or open attachments unless verified. Send all suspicious email as an attachment to report.spam@nc.gov.

Dear Division of Air Quality,

I am writing to urge DEQ to wisely invest the \$92 million in Volkswagen settlement funds in electric vehicles and infrastructure. Taking advantage of these funds to jumpstart the electrification of North Carolina's transportation sector will mean less money sent out of state for petroleum, more in-state jobs, and cleaner air.

Specifically, I recommend that DEQ allocate the maximum allowable amount (15%) of the funds for electric vehicle charging infrastructure and installations. And I encourage DEQ to prioritize electric vehicles and buses for replacement whenever possible with the other 85% of the settlement funds. Doing so will maximize the local economic impact and the reduction of air pollution.

I encourage you to not use the funding for natural gas, propane or diesel vehicles. Further dependence on fossil fuels means more pollution. Only a transition to electric vehicles and investment in EV infrastructure will put us on the road to a 100% clean transportation sector in North Carolina.

Sincerely,

Gordon Barber
300 Long Shoals Rd, Apt 4E
Arden, NC 28704
resonus@gmail.com
(704) 453-1028

This message was sent by KnowWho, as a service provider only, on behalf of the individual noted in the sender information.

From: John Stratton (johnstratton55@gmail.com) Sent You a Personal Message
To: [daq.NC_VWGrants](#)
Subject: [External] Use Volkswagen funds to electrify NC transportation
Date: Tuesday, December 05, 2017 8:32:36 PM

CAUTION: External email. Do not click links or open attachments unless verified. Send all suspicious email as an attachment to report.spam@nc.gov.

Dear Division of Air Quality,

I am writing to urge DEQ to wisely invest the \$92 million in Volkswagen settlement funds in electric vehicles and infrastructure. Taking advantage of these funds to jumpstart the electrification of North Carolina's transportation sector will mean less money sent out of state for petroleum, more in-state jobs, and cleaner air.

Specifically, I recommend that DEQ allocate the maximum allowable amount (15%) of the funds for electric vehicle charging infrastructure and installations. And I encourage DEQ to prioritize electric vehicles and buses for replacement whenever possible with the other 85% of the settlement funds. Doing so will maximize the local economic impact and the reduction of air pollution.

I encourage you to not use the funding for natural gas, propane or diesel vehicles. Further dependence on fossil fuels means more pollution. Only a transition to electric vehicles and investment in EV infrastructure will put us on the road to a 100% clean transportation sector in North Carolina.

Sincerely,

John Stratton
2005 BRENTWOOD DR
ROCKY MOUNT, NC 27804
johnstratton55@gmail.com
(252) 972-3508

This message was sent by KnowWho, as a service provider only, on behalf of the individual noted in the sender information.

From: Suzanne J Dickson (szpressroom@yahoo.com) Sent You a Personal Message
To: [daq.NC_VWGrants](#)
Subject: [External] Use Volkswagen funds to electrify NC transportation
Date: Tuesday, December 05, 2017 8:32:36 PM

CAUTION: External email. Do not click links or open attachments unless verified. Send all suspicious email as an attachment to report.spam@nc.gov.

Dear Division of Air Quality,

I am writing to urge DEQ to wisely invest the \$92 million in Volkswagen settlement funds in electric vehicles and infrastructure. Taking advantage of these funds to jumpstart the electrification of North Carolina's transportation sector will mean less money sent out of state for petroleum, more in-state jobs, and cleaner air.

Specifically, I recommend that DEQ allocate the maximum allowable amount (15%) of the funds for electric vehicle charging infrastructure and installations. And I encourage DEQ to prioritize electric vehicles and buses for replacement whenever possible with the other 85% of the settlement funds. Doing so will maximize the local economic impact and the reduction of air pollution.

I encourage you to not use the funding for natural gas, propane or diesel vehicles. Further dependence on fossil fuels means more pollution. Only a transition to electric vehicles and investment in EV infrastructure will put us on the road to a 100% clean transportation sector in North Carolina.

Sincerely,

Suzanne J Dickson
P.O.Box 1081
Sneads Ferry, NC 28460
szpressroom@yahoo.com
(603) 702-2001

This message was sent by KnowWho, as a service provider only, on behalf of the individual noted in the sender information.

From: Kathleen McQuaid (kemcquaid@outlook.com) Sent You a Personal Message
To: [daq.NC_VWGrants](#)
Subject: [External] Use Volkswagen funds to electrify NC transportation
Date: Tuesday, December 05, 2017 8:30:48 PM

CAUTION: External email. Do not click links or open attachments unless verified. Send all suspicious email as an attachment to report.spam@nc.gov.

Dear Division of Air Quality,

I am writing to urge DEQ to wisely invest the \$92 million in Volkswagen settlement funds in electric vehicles and infrastructure. Taking advantage of these funds to jumpstart the electrification of North Carolina's transportation sector will mean less money sent out of state for petroleum, more in-state jobs, and cleaner air.

Specifically, I recommend that DEQ allocate the maximum allowable amount (15%) of the funds for electric vehicle charging infrastructure and installations. And I encourage DEQ to prioritize electric vehicles and buses for replacement whenever possible with the other 85% of the settlement funds. Doing so will maximize the local economic impact and the reduction of air pollution.

I encourage you to not use the funding for natural gas, propane or diesel vehicles. Further dependence on fossil fuels means more pollution. Only a transition to electric vehicles and investment in EV infrastructure will put us on the road to a 100% clean transportation sector in North Carolina.

Sincerely,

Kathleen McQuaid
PO Box 6027
Raleigh, NC 27628
kemcquaid@outlook.com
(919) 829-0249

This message was sent by KnowWho, as a service provider only, on behalf of the individual noted in the sender information.

From: Allison Kaika (kaika@bc.edu) Sent You a Personal Message
To: [daq.NC_VWGrants](#)
Subject: [External] Use Volkswagen funds to electrify NC transportation
Date: Tuesday, December 05, 2017 8:30:46 PM

CAUTION: External email. Do not click links or open attachments unless verified. Send all suspicious email as an attachment to report.spam@nc.gov.

Dear Division of Air Quality,

I am writing to urge DEQ to wisely invest the \$92 million in Volkswagen settlement funds in electric vehicles and infrastructure. Taking advantage of these funds to jumpstart the electrification of North Carolina's transportation sector will mean less money sent out of state for petroleum, more in-state jobs, and cleaner air.

Specifically, I recommend that DEQ allocate the maximum allowable amount (15%) of the funds for electric vehicle charging infrastructure and installations. And I encourage DEQ to prioritize electric vehicles and buses for replacement whenever possible with the other 85% of the settlement funds. Doing so will maximize the local economic impact and the reduction of air pollution.

I encourage you to not use the funding for natural gas, propane or diesel vehicles. Further dependence on fossil fuels means more pollution. Only a transition to electric vehicles and investment in EV infrastructure will put us on the road to a 100% clean transportation sector in North Carolina.

Sincerely,

Allison Kaika
523 Briar Patch Terrace
Waxhaw, NC 28173
kaika@bc.edu
(704) 516-4086

This message was sent by KnowWho, as a service provider only, on behalf of the individual noted in the sender information.

From: Donnie Davis (barbanddon@etinternet.net) Sent You a Personal Message
To: [daq.NC_VWGrants](#)
Subject: [External] Use Volkswagen funds to electrify NC transportation
Date: Tuesday, December 05, 2017 8:29:42 PM

CAUTION: External email. Do not click links or open attachments unless verified. Send all suspicious email as an attachment to report.spam@nc.gov.

Dear Division of Air Quality,

I am writing to urge DEQ to wisely invest the \$92 million in Volkswagen settlement funds in electric vehicles and infrastructure. Taking advantage of these funds to jumpstart the electrification of North Carolina's transportation sector will mean less money sent out of state for petroleum, more in-state jobs, and cleaner air.

Specifically, I recommend that DEQ allocate the maximum allowable amount (15%) of the funds for electric vehicle charging infrastructure and installations. And I encourage DEQ to prioritize electric vehicles and buses for replacement whenever possible with the other 85% of the settlement funds. Doing so will maximize the local economic impact and the reduction of air pollution.

I encourage you to not use the funding for natural gas, propane or diesel vehicles. Further dependence on fossil fuels means more pollution. Only a transition to electric vehicles and investment in EV infrastructure will put us on the road to a 100% clean transportation sector in North Carolina.

Sincerely,

Donnie Davis
239 Bowers Lane
Ellerbe, NC 28338
barbanddon@etinternet.net
(910) 652-2707

This message was sent by KnowWho, as a service provider only, on behalf of the individual noted in the sender information.

From: Phillip Davis (phillipdavis100@yahoo.com) Sent You a Personal Message
To: [daq.NC_VWGrants](#)
Subject: [External] Use Volkswagen funds to electrify NC transportation
Date: Tuesday, December 05, 2017 8:29:13 PM

CAUTION: External email. Do not click links or open attachments unless verified. Send all suspicious email as an attachment to report.spam@nc.gov.

Dear Division of Air Quality,

I am writing to urge DEQ to wisely invest the \$92 million in Volkswagen settlement funds in electric vehicles and infrastructure. Taking advantage of these funds to jumpstart the electrification of North Carolina's transportation sector will mean less money sent out of state for petroleum, more in-state jobs, and cleaner air.

Specifically, I recommend that DEQ allocate the maximum allowable amount (15%) of the funds for electric vehicle charging infrastructure and installations. And I encourage DEQ to prioritize electric vehicles and buses for replacement whenever possible with the other 85% of the settlement funds. Doing so will maximize the local economic impact and the reduction of air pollution.

I encourage you to not use the funding for natural gas, propane or diesel vehicles. Further dependence on fossil fuels means more pollution. Only a transition to electric vehicles and investment in EV infrastructure will put us on the road to a 100% clean transportation sector in North Carolina.

Sincerely,

Phillip Davis
239 Bowers Lane
Ellerbe, NC 28338
phillipdavis100@yahoo.com
(910) 995-3560

This message was sent by KnowWho, as a service provider only, on behalf of the individual noted in the sender information.

From: William Moore (srwhmoore@comporium.net) Sent You a Personal Message
To: [daq.NC_VWGrants](#)
Subject: [External] Use Volkswagen funds to electrify NC transportation
Date: Tuesday, December 05, 2017 8:28:37 PM

CAUTION: External email. Do not click links or open attachments unless verified. Send all suspicious email as an attachment to report.spam@nc.gov.

Dear Division of Air Quality,

I am writing to urge DEQ to wisely invest the \$92 million in Volkswagen settlement funds in electric vehicles and infrastructure. Taking advantage of these funds to jumpstart the electrification of North Carolina's transportation sector will mean less money sent out of state for petroleum, more in-state jobs, and cleaner air.

Specifically, I recommend that DEQ allocate the maximum allowable amount (15%) of the funds for electric vehicle charging infrastructure and installations. And I encourage DEQ to prioritize electric vehicles and buses for replacement whenever possible with the other 85% of the settlement funds. Doing so will maximize the local economic impact and the reduction of air pollution.

I encourage you to not use the funding for natural gas, propane or diesel vehicles. Further dependence on fossil fuels means more pollution. Only a transition to electric vehicles and investment in EV infrastructure will put us on the road to a 100% clean transportation sector in North Carolina.

Sincerely,

William Moore
100 N College Row Apt 245
William, NC 28712
srwhmoore@comporium.net
(828) 877-6621

This message was sent by KnowWho, as a service provider only, on behalf of the individual noted in the sender information.

From: James Sakolosky (jsakolosky@gmail.com) Sent You a Personal Message
To: [daq.NC_VWGrants](#)
Subject: [External] Use Volkswagen funds to electrify NC transportation
Date: Tuesday, December 05, 2017 8:25:59 PM

CAUTION: External email. Do not click links or open attachments unless verified. Send all suspicious email as an attachment to report.spam@nc.gov.

Dear Division of Air Quality,

I am writing to urge DEQ to wisely invest the \$92 million in Volkswagen settlement funds in electric vehicles and infrastructure. Taking advantage of these funds to jumpstart the electrification of North Carolina's transportation sector will mean less money sent out of state for petroleum, more in-state jobs, and cleaner air.

Specifically, I recommend that DEQ allocate the maximum allowable amount (15%) of the funds for electric vehicle charging infrastructure and installations. And I encourage DEQ to prioritize electric vehicles and buses for replacement whenever possible with the other 85% of the settlement funds. Doing so will maximize the local economic impact and the reduction of air pollution.

I encourage you to not use the funding for natural gas, propane or diesel vehicles. Further dependence on fossil fuels means more pollution. Only a transition to electric vehicles and investment in EV infrastructure will put us on the road to a 100% clean transportation sector in North Carolina.

Sincerely,

James Sakolosky
113 Nixonton Loop
Elizabeth jCity, NC 27909
jsakolosky@gmail.com
(252) 264-1318

This message was sent by KnowWho, as a service provider only, on behalf of the individual noted in the sender information.

From: Andrew Sweatt (andrew_sweatt@my.uri.edu) Sent You a Personal Message
To: [daq.NC_VWGrants](#)
Subject: [External] Use Volkswagen funds to electrify NC transportation
Date: Tuesday, December 05, 2017 8:25:59 PM

CAUTION: External email. Do not click links or open attachments unless verified. Send all suspicious email as an attachment to report.spam@nc.gov.

Dear Division of Air Quality,

I am writing to urge DEQ to wisely invest the \$92 million in Volkswagen settlement funds in electric vehicles and infrastructure. Taking advantage of these funds to jumpstart the electrification of North Carolina's transportation sector will mean less money sent out of state for petroleum, more in-state jobs, and cleaner air.

Specifically, I recommend that DEQ allocate the maximum allowable amount (15%) of the funds for electric vehicle charging infrastructure and installations. And I encourage DEQ to prioritize electric vehicles and buses for replacement whenever possible with the other 85% of the settlement funds. Doing so will maximize the local economic impact and the reduction of air pollution.

I encourage you to not use the funding for natural gas, propane or diesel vehicles. Further dependence on fossil fuels means more pollution. Only a transition to electric vehicles and investment in EV infrastructure will put us on the road to a 100% clean transportation sector in North Carolina.

Sincerely,

Andrew Sweatt
850 Watson Avenue
Winston-Salem, NC 27103
andrew_sweatt@my.uri.edu
(336) 486-0501

This message was sent by KnowWho, as a service provider only, on behalf of the individual noted in the sender information.

From: Dean Holmes (dnholmes34@yahoo.com) Sent You a Personal Message
To: [daq.NC_VWGrants](#)
Subject: [External] Use Volkswagen funds to electrify NC transportation
Date: Tuesday, December 05, 2017 8:25:24 PM

CAUTION: External email. Do not click links or open attachments unless verified. Send all suspicious email as an attachment to report.spam@nc.gov.

Dear Division of Air Quality,

I am writing to urge DEQ to wisely invest the \$92 million in Volkswagen settlement funds in electric vehicles and infrastructure. Taking advantage of these funds to jumpstart the electrification of North Carolina's transportation sector will mean less money sent out of state for petroleum, more in-state jobs, and cleaner air.

Specifically, I recommend that DEQ allocate the maximum allowable amount (15%) of the funds for electric vehicle charging infrastructure and installations. And I encourage DEQ to prioritize electric vehicles and buses for replacement whenever possible with the other 85% of the settlement funds. Doing so will maximize the local economic impact and the reduction of air pollution.

I encourage you to not use the funding for natural gas, propane or diesel vehicles. Further dependence on fossil fuels means more pollution. Only a transition to electric vehicles and investment in EV infrastructure will put us on the road to a 100% clean transportation sector in North Carolina.

Sincerely,

Dean Holmes
188 Gurganus Road
Maple Hill, NC 28454
dnholmes34@yahoo.com
(910) 459-2568

This message was sent by KnowWho, as a service provider only, on behalf of the individual noted in the sender information.

From: Megan Kelly Deyncourt (megan.kelly87@gmail.com) Sent You a Personal Message
To: [daq.NC_VWGrants](#)
Subject: [External] Use Volkswagen funds to electrify NC transportation
Date: Tuesday, December 05, 2017 8:22:36 PM

CAUTION: External email. Do not click links or open attachments unless verified. Send all suspicious email as an attachment to report.spam@nc.gov.

Dear Division of Air Quality,

I am writing to urge DEQ to wisely invest the \$92 million in Volkswagen settlement funds in electric vehicles and infrastructure. Taking advantage of these funds to jumpstart the electrification of North Carolina's transportation sector will mean less money sent out of state for petroleum, more in-state jobs, and cleaner air.

Specifically, I recommend that DEQ allocate the maximum allowable amount (15%) of the funds for electric vehicle charging infrastructure and installations. And I encourage DEQ to prioritize electric vehicles and buses for replacement whenever possible with the other 85% of the settlement funds. Doing so will maximize the local economic impact and the reduction of air pollution.

I encourage you to not use the funding for natural gas, propane or diesel vehicles. Further dependence on fossil fuels means more pollution. Only a transition to electric vehicles and investment in EV infrastructure will put us on the road to a 100% clean transportation sector in North Carolina.

Sincerely,

Megan Kelly Deyncourt
608 Jumping Frog Lane
Knightdale, NC 27545
megan.kelly87@gmail.com
(757) 739-1136

This message was sent by KnowWho, as a service provider only, on behalf of the individual noted in the sender information.

From: Rosemary Carton (rccarton50@gmail.com) Sent You a Personal Message
To: [daq.NC_VWGrants](#)
Subject: [External] Use Volkswagen funds to electrify NC transportation
Date: Tuesday, December 05, 2017 8:19:43 PM

CAUTION: External email. Do not click links or open attachments unless verified. Send all suspicious email as an attachment to report.spam@nc.gov.

Dear Division of Air Quality,

I am writing to urge DEQ to wisely invest the \$92 million in Volkswagen settlement funds in electric vehicles and infrastructure. Taking advantage of these funds to jumpstart the electrification of North Carolina's transportation sector will mean less money sent out of state for petroleum, more in-state jobs, and cleaner air.

Specifically, I recommend that DEQ allocate the maximum allowable amount (15%) of the funds for electric vehicle charging infrastructure and installations. And I encourage DEQ to prioritize electric vehicles and buses for replacement whenever possible with the other 85% of the settlement funds. Doing so will maximize the local economic impact and the reduction of air pollution.

I encourage you to not use the funding for natural gas, propane or diesel vehicles. Further dependence on fossil fuels means more pollution. Only a transition to electric vehicles and investment in EV infrastructure will put us on the road to a 100% clean transportation sector in North Carolina.

Sincerely,

Rosemary Carton
4004 Traditions Court
St James, NC 28461
rccarton50@gmail.com
(240) 388-5353

This message was sent by KnowWho, as a service provider only, on behalf of the individual noted in the sender information.

From: ROBERT McGahey (rmcgahey@main.nc.us) Sent You a Personal Message
To: [daq.NC_VWGrants](#)
Subject: [External] Use Volkswagen funds to electrify NC transportation
Date: Tuesday, December 05, 2017 8:19:41 PM

CAUTION: External email. Do not click links or open attachments unless verified. Send all suspicious email as an attachment to report.spam@nc.gov.

Dear Division of Air Quality,

I am writing to urge DEQ to wisely invest the \$92 million in Volkswagen settlement funds in electric vehicles and infrastructure. Taking advantage of these funds to jumpstart the electrification of North Carolina's transportation sector will mean less money sent out of state for petroleum, more in-state jobs, and cleaner air.

Specifically, I recommend that DEQ allocate the maximum allowable amount (15%) of the funds for electric vehicle charging infrastructure and installations. And I encourage DEQ to prioritize electric vehicles and buses for replacement whenever possible with the other 85% of the settlement funds. Doing so will maximize the local economic impact and the reduction of air pollution.

I encourage you to not use the funding for natural gas, propane or diesel vehicles. Further dependence on fossil fuels means more pollution. Only a transition to electric vehicles and investment in EV infrastructure will put us on the road to a 100% clean transportation sector in North Carolina.

Sincerely,

ROBERT McGahey
300 Dharma Way
Burnsville, NC 28714
rmcgahey@main.nc.us
(828) 675-5535

This message was sent by KnowWho, as a service provider only, on behalf of the individual noted in the sender information.

From: David Judd (djudd24@gmail.com) Sent You a Personal Message
To: [daq.NC_VWGrants](#)
Subject: [External] Use Volkswagen funds to electrify NC transportation
Date: Tuesday, December 05, 2017 8:17:43 PM

CAUTION: External email. Do not click links or open attachments unless verified. Send all suspicious email as an attachment to report.spam@nc.gov.

Dear Division of Air Quality,

I am writing to urge DEQ to wisely invest the \$92 million in Volkswagen settlement funds in electric vehicles and infrastructure. Taking advantage of these funds to jumpstart the electrification of North Carolina's transportation sector will mean less money sent out of state for petroleum, more in-state jobs, and cleaner air.

Specifically, I recommend that DEQ allocate the maximum allowable amount (15%) of the funds for electric vehicle charging infrastructure and installations. And I encourage DEQ to prioritize electric vehicles and buses for replacement whenever possible with the other 85% of the settlement funds. Doing so will maximize the local economic impact and the reduction of air pollution.

I encourage you to not use the funding for natural gas, propane or diesel vehicles. Further dependence on fossil fuels means more pollution. Only a transition to electric vehicles and investment in EV infrastructure will put us on the road to a 100% clean transportation sector in North Carolina.

Sincerely,

David Judd
294 Glenn Bridge Road
Arden, NC 28704
djudd24@gmail.com
(828) 280-2011

This message was sent by KnowWho, as a service provider only, on behalf of the individual noted in the sender information.

From: Nan Martin (nanpmartin@yahoo.com) Sent You a Personal Message
To: [daq.NC_VWGrants](#)
Subject: [External] Use Volkswagen funds to electrify NC transportation
Date: Tuesday, December 05, 2017 8:17:05 PM

CAUTION: External email. Do not click links or open attachments unless verified. Send all suspicious email as an attachment to report.spam@nc.gov.

Dear Division of Air Quality,

I am writing to urge DEQ to wisely invest the \$92 million in Volkswagen settlement funds in electric vehicles and infrastructure. Taking advantage of these funds to jumpstart the electrification of North Carolina's transportation sector will mean less money sent out of state for petroleum, more in-state jobs, and cleaner air.

Specifically, I recommend that DEQ allocate the maximum allowable amount (15%) of the funds for electric vehicle charging infrastructure and installations. And I encourage DEQ to prioritize electric vehicles and buses for replacement whenever possible with the other 85% of the settlement funds. Doing so will maximize the local economic impact and the reduction of air pollution.

I encourage you to not use the funding for natural gas, propane or diesel vehicles. Further dependence on fossil fuels means more pollution. Only a transition to electric vehicles and investment in EV infrastructure will put us on the road to a 100% clean transportation sector in North Carolina.

Sincerely,

Nan Martin
`1110 Pebble Creek Crossing
Durham, NC 27713
nanpmartin@yahoo.com
(919) 467-5338

This message was sent by KnowWho, as a service provider only, on behalf of the individual noted in the sender information.

From: Tim Zerr (taosword47@hotmail.com) Sent You a Personal Message
To: [daq.NC_VWGrants](#)
Subject: [External] Use Volkswagen funds to electrify NC transportation
Date: Tuesday, December 05, 2017 8:16:30 PM

CAUTION: External email. Do not click links or open attachments unless verified. Send all suspicious email as an attachment to report.spam@nc.gov.

Dear Division of Air Quality,

I am writing to urge DEQ to wisely invest the \$92 million in Volkswagen settlement funds in electric vehicles and infrastructure. Taking advantage of these funds to jumpstart the electrification of North Carolina's transportation sector will mean less money sent out of state for petroleum, more in-state jobs, and cleaner air.

Specifically, I recommend that DEQ allocate the maximum allowable amount (15%) of the funds for electric vehicle charging infrastructure and installations. And I encourage DEQ to prioritize electric vehicles and buses for replacement whenever possible with the other 85% of the settlement funds. Doing so will maximize the local economic impact and the reduction of air pollution.

I encourage you to not use the funding for natural gas, propane or diesel vehicles. Further dependence on fossil fuels means more pollution. Only a transition to electric vehicles and investment in EV infrastructure will put us on the road to a 100% clean transportation sector in North Carolina.

Sincerely,

Tim Zerr
3237 Bragg Drive, 28
Wilmington, NC 28409
taosword47@hotmail.com
(910) 399-2716

This message was sent by KnowWho, as a service provider only, on behalf of the individual noted in the sender information.

From: Jeremy Marzuola (jlmazuola@gmail.com) Sent You a Personal Message
To: [daq.NC_VWGrants](#)
Subject: [External] Use Volkswagen funds to electrify NC transportation
Date: Tuesday, December 05, 2017 8:14:18 PM

CAUTION: External email. Do not click links or open attachments unless verified. Send all suspicious email as an attachment to report.spam@nc.gov.

Dear Division of Air Quality,

I am writing to urge DEQ to wisely invest the \$92 million in Volkswagen settlement funds in electric vehicles and infrastructure. Taking advantage of these funds to jumpstart the electrification of North Carolina's transportation sector will mean less money sent out of state for petroleum, more in-state jobs, and cleaner air.

Specifically, I recommend that DEQ allocate the maximum allowable amount (15%) of the funds for electric vehicle charging infrastructure and installations. And I encourage DEQ to prioritize electric vehicles and buses for replacement whenever possible with the other 85% of the settlement funds. Doing so will maximize the local economic impact and the reduction of air pollution.

I encourage you to not use the funding for natural gas, propane or diesel vehicles. Further dependence on fossil fuels means more pollution. Only a transition to electric vehicles and investment in EV infrastructure will put us on the road to a 100% clean transportation sector in North Carolina.

Sincerely,

Jeremy Marzuola
705 W Main St
Carrboro, NC 27510
jlmazuola@gmail.com
(510) 435-9685

This message was sent by KnowWho, as a service provider only, on behalf of the individual noted in the sender information.

From: Doug Wingeier (dcwing@main.nc.us) Sent You a Personal Message
To: [daq.NC_VWGrants](#)
Subject: [External] Use Volkswagen funds to electrify NC transportation
Date: Tuesday, December 05, 2017 8:10:00 PM

CAUTION: External email. Do not click links or open attachments unless verified. Send all suspicious email as an attachment to report.spam@nc.gov.

Dear Division of Air Quality,

I am writing to urge DEQ to wisely invest the \$92 million in Volkswagen settlement funds in electric vehicles and infrastructure. Taking advantage of these funds to jumpstart the electrification of North Carolina's transportation sector will mean less money sent out of state for petroleum, more in-state jobs, and cleaner air.

Specifically, I recommend that DEQ allocate the maximum allowable amount (15%) of the funds for electric vehicle charging infrastructure and installations. And I encourage DEQ to prioritize electric vehicles and buses for replacement whenever possible with the other 85% of the settlement funds. Doing so will maximize the local economic impact and the reduction of air pollution.

I encourage you to not use the funding for natural gas, propane or diesel vehicles. Further dependence on fossil fuels means more pollution. Only a transition to electric vehicles and investment in EV infrastructure will put us on the road to a 100% clean transportation sector in North Carolina.

Sincerely,

Doug Wingeier
266 Merrimon Ave.
Asheville, NC 28801
dcwing@main.nc.us
(828) 246-4885

This message was sent by KnowWho, as a service provider only, on behalf of the individual noted in the sender information.

From: George Phillips (nctrack@gmail.com) Sent You a Personal Message
To: daq.NC_VWGrants
Subject: [External] Use Volkswagen funds to electrify NC transportation
Date: Tuesday, December 05, 2017 8:09:03 PM

CAUTION: External email. Do not click links or open attachments unless verified. Send all suspicious email as an attachment to report.spam@nc.gov.

Dear Division of Air Quality,

I am writing to urge DEQ to wisely invest the \$92 million in Volkswagen settlement funds in electric vehicles and infrastructure. Taking advantage of these funds to jumpstart the electrification of North Carolina's transportation sector will mean less money sent out of state for petroleum, more in-state jobs, and cleaner air.

Specifically, I recommend that DEQ allocate the maximum allowable amount (15%) of the funds for electric vehicle charging infrastructure and installations. And I encourage DEQ to prioritize electric vehicles and buses for replacement whenever possible with the other 85% of the settlement funds. Doing so will maximize the local economic impact and the reduction of air pollution.

I encourage you to not use the funding for natural gas, propane or diesel vehicles. Further dependence on fossil fuels means more pollution. Only a transition to electric vehicles and investment in EV infrastructure will put us on the road to a 100% clean transportation sector in North Carolina.

Sincerely,

George Phillips
1140 Carousel Ln
Hendersonville, NC 28792
nctrack@gmail.com
(999) 999-9999

This message was sent by KnowWho, as a service provider only, on behalf of the individual noted in the sender information.

From: carole Henry (vandykee@rtelco.net) Sent You a Personal Message
To: [daq.NC_VWGrants](#)
Subject: [External] Use Volkswagen funds to electrify NC transportation
Date: Tuesday, December 05, 2017 8:08:09 PM

CAUTION: External email. Do not click links or open attachments unless verified. Send all suspicious email as an attachment to report.spam@nc.gov.

Dear Division of Air Quality,

I am writing to urge DEQ to wisely invest the \$92 million in Volkswagen settlement funds in electric vehicles and infrastructure. Taking advantage of these funds to jumpstart the electrification of North Carolina's transportation sector will mean less money sent out of state for petroleum, more in-state jobs, and cleaner air.

Specifically, I recommend that DEQ allocate the maximum allowable amount (15%) of the funds for electric vehicle charging infrastructure and installations. And I encourage DEQ to prioritize electric vehicles and buses for replacement whenever possible with the other 85% of the settlement funds. Doing so will maximize the local economic impact and the reduction of air pollution.

I encourage you to not use the funding for natural gas, propane or diesel vehicles. Further dependence on fossil fuels means more pollution. Only a transition to electric vehicles and investment in EV infrastructure will put us on the road to a 100% clean transportation sector in North Carolina.

Sincerely,

carole Henry
Bx 86
Bonlee, NC 27213
vandykee@rtelco.net
(919) 663-5838

This message was sent by KnowWho, as a service provider only, on behalf of the individual noted in the sender information.

From: wes weaver (weaverwm@bellsouth.net) Sent You a Personal Message
To: [daq.NC_VWGrants](#)
Subject: [External] Use Volkswagen funds to electrify NC transportation
Date: Tuesday, December 05, 2017 8:08:08 PM

CAUTION: External email. Do not click links or open attachments unless verified. Send all suspicious email as an attachment to report.spam@nc.gov.

Dear Division of Air Quality,

I am writing to urge DEQ to wisely invest the \$92 million in Volkswagen settlement funds in electric vehicles and infrastructure. Taking advantage of these funds to jumpstart the electrification of North Carolina's transportation sector will mean less money sent out of state for petroleum, more in-state jobs, and cleaner air.

Specifically, I recommend that DEQ allocate the maximum allowable amount (15%) of the funds for electric vehicle charging infrastructure and installations. And I encourage DEQ to prioritize electric vehicles and buses for replacement whenever possible with the other 85% of the settlement funds. Doing so will maximize the local economic impact and the reduction of air pollution.

I encourage you to not use the funding for natural gas, propane or diesel vehicles. Further dependence on fossil fuels means more pollution. Only a transition to electric vehicles and investment in EV infrastructure will put us on the road to a 100% clean transportation sector in North Carolina.

Sincerely,

wes weaver
342 dogwood knoll
boone, NC 28607
weaverwm@bellsouth.net
(828) 264-9316

This message was sent by KnowWho, as a service provider only, on behalf of the individual noted in the sender information.

From: John Wiles (jwiles3rd@gmail.com) Sent You a Personal Message
To: [daq.NC_VWGrants](#)
Subject: [External] Use Volkswagen funds to electrify NC transportation
Date: Tuesday, December 05, 2017 8:07:55 PM

CAUTION: External email. Do not click links or open attachments unless verified. Send all suspicious email as an attachment to report.spam@nc.gov.

Dear Division of Air Quality,

I am writing to urge DEQ to wisely invest the \$92 million in Volkswagen settlement funds in electric vehicles and infrastructure. Taking advantage of these funds to jumpstart the electrification of North Carolina's transportation sector will mean less money sent out of state for petroleum, more in-state jobs, and cleaner air.

Specifically, I recommend that DEQ allocate the maximum allowable amount (15%) of the funds for electric vehicle charging infrastructure and installations. And I encourage DEQ to prioritize electric vehicles and buses for replacement whenever possible with the other 85% of the settlement funds. Doing so will maximize the local economic impact and the reduction of air pollution.

I encourage you to not use the funding for natural gas, propane or diesel vehicles. Further dependence on fossil fuels means more pollution. Only a transition to electric vehicles and investment in EV infrastructure will put us on the road to a 100% clean transportation sector in North Carolina.

Sincerely,

John Wiles
5205 Langford Ter
Durham, NC 27713
jwiles3rd@gmail.com
(901) 301-8894

This message was sent by KnowWho, as a service provider only, on behalf of the individual noted in the sender information.

From: Sreenath Sharma (sreenathsharma2@gmail.com) Sent You a Personal Message
To: [daq.NC_VWGrants](#)
Subject: [External] Use Volkswagen funds to electrify NC transportation
Date: Tuesday, December 05, 2017 8:05:30 PM

CAUTION: External email. Do not click links or open attachments unless verified. Send all suspicious email as an attachment to report.spam@nc.gov.

Dear Division of Air Quality,

I am writing to urge DEQ to wisely invest the \$92 million in Volkswagen settlement funds in electric vehicles and infrastructure. Taking advantage of these funds to jumpstart the electrification of North Carolina's transportation sector will mean less money sent out of state for petroleum, more in-state jobs, and cleaner air.

Specifically, I recommend that DEQ allocate the maximum allowable amount (15%) of the funds for electric vehicle charging infrastructure and installations. And I encourage DEQ to prioritize electric vehicles and buses for replacement whenever possible with the other 85% of the settlement funds. Doing so will maximize the local economic impact and the reduction of air pollution.

I encourage you to not use the funding for natural gas, propane or diesel vehicles. Further dependence on fossil fuels means more pollution. Only a transition to electric vehicles and investment in EV infrastructure will put us on the road to a 100% clean transportation sector in North Carolina.

Sincerely,

Sreenath Sharma
1918 Bearkling Place
Chapel Hill, NC 27517
sreenathsharma2@gmail.com
(919) 259-1769

This message was sent by KnowWho, as a service provider only, on behalf of the individual noted in the sender information.

From: Cindy McMorris (cindymcmorris@att.net) Sent You a Personal Message
To: [daq.NC_VWGrants](#)
Subject: [External] Use Volkswagen funds to electrify NC transportation
Date: Tuesday, December 05, 2017 8:01:39 PM

CAUTION: External email. Do not click links or open attachments unless verified. Send all suspicious email as an attachment to report.spam@nc.gov.

Dear Division of Air Quality,

I am writing to urge DEQ to wisely invest the \$92 million in Volkswagen settlement funds in electric vehicles and infrastructure. Taking advantage of these funds to jumpstart the electrification of North Carolina's transportation sector will mean less money sent out of state for petroleum, more in-state jobs, and cleaner air.

Specifically, I recommend that DEQ allocate the maximum allowable amount (15%) of the funds for electric vehicle charging infrastructure and installations. And I encourage DEQ to prioritize electric vehicles and buses for replacement whenever possible with the other 85% of the settlement funds. Doing so will maximize the local economic impact and the reduction of air pollution.

I encourage you to not use the funding for natural gas, propane or diesel vehicles. Further dependence on fossil fuels means more pollution. Only a transition to electric vehicles and investment in EV infrastructure will put us on the road to a 100% clean transportation sector in North Carolina.

Sincerely,

Cindy McMorris
8916 Langwood Dr #104
Raleigh, NC 27613
cindymcmorris@att.net
(513) 578-3125

This message was sent by KnowWho, as a service provider only, on behalf of the individual noted in the sender information.

From: Margaret Silvers (marsilvers@gmail.com) Sent You a Personal Message
To: [daq.NC_VWGrants](#)
Subject: [External] Use Volkswagen funds to electrify NC transportation
Date: Tuesday, December 05, 2017 7:57:41 PM

CAUTION: External email. Do not click links or open attachments unless verified. Send all suspicious email as an attachment to report.spam@nc.gov.

Dear Division of Air Quality,

I am writing to urge DEQ to wisely invest the \$92 million in Volkswagen settlement funds in electric vehicles and infrastructure. Taking advantage of these funds to jumpstart the electrification of North Carolina's transportation sector will mean less money sent out of state for petroleum, more in-state jobs, and cleaner air.

Specifically, I recommend that DEQ allocate the maximum allowable amount (15%) of the funds for electric vehicle charging infrastructure and installations. And I encourage DEQ to prioritize electric vehicles and buses for replacement whenever possible with the other 85% of the settlement funds. Doing so will maximize the local economic impact and the reduction of air pollution.

I encourage you to not use the funding for natural gas, propane or diesel vehicles. Further dependence on fossil fuels means more pollution. Only a transition to electric vehicles and investment in EV infrastructure will put us on the road to a 100% clean transportation sector in North Carolina.

Sincerely,

Margaret Silvers
947 Hwy 9 South
Mill Spring, NC 28756
marsilvers@gmail.com
(828) 894-9365

This message was sent by KnowWho, as a service provider only, on behalf of the individual noted in the sender information.

From: John Mickey (jcmickey@hotmail.com) Sent You a Personal Message
To: [daq.NC_VWGrants](#)
Subject: [External] Use Volkswagen funds to electrify NC transportation
Date: Tuesday, December 05, 2017 7:57:11 PM

CAUTION: External email. Do not click links or open attachments unless verified. Send all suspicious email as an attachment to report.spam@nc.gov.

Dear Division of Air Quality,

I am writing to urge DEQ to wisely invest the \$92 million in Volkswagen settlement funds in electric vehicles and infrastructure. Taking advantage of these funds to jumpstart the electrification of North Carolina's transportation sector will mean less money sent out of state for petroleum, more in-state jobs, and cleaner air.

Specifically, I recommend that DEQ allocate the maximum allowable amount (15%) of the funds for electric vehicle charging infrastructure and installations. And I encourage DEQ to prioritize electric vehicles and buses for replacement whenever possible with the other 85% of the settlement funds. Doing so will maximize the local economic impact and the reduction of air pollution.

I encourage you to not use the funding for natural gas, propane or diesel vehicles. Further dependence on fossil fuels means more pollution. Only a transition to electric vehicles and investment in EV infrastructure will put us on the road to a 100% clean transportation sector in North Carolina.

Sincerely,

John Mickey
3540 Round Oak Rd.
Charlotte, NC 28210
jcmickey@hotmail.com
(704) 759-4850

This message was sent by KnowWho, as a service provider only, on behalf of the individual noted in the sender information.

From: Lee Rouse (tlrouse@gmail.com) Sent You a Personal Message
To: [daq.NC_VWGrants](#)
Subject: [External] Use Volkswagen funds to electrify NC transportation
Date: Tuesday, December 05, 2017 7:55:59 PM

CAUTION: External email. Do not click links or open attachments unless verified. Send all suspicious email as an attachment to report.spam@nc.gov.

Dear Division of Air Quality,

I am writing to urge DEQ to wisely invest the \$92 million in Volkswagen settlement funds in electric vehicles and infrastructure. Taking advantage of these funds to jumpstart the electrification of North Carolina's transportation sector will mean less money sent out of state for petroleum, more in-state jobs, and cleaner air.

Specifically, I recommend that DEQ allocate the maximum allowable amount (15%) of the funds for electric vehicle charging infrastructure and installations. And I encourage DEQ to prioritize electric vehicles and buses for replacement whenever possible with the other 85% of the settlement funds. Doing so will maximize the local economic impact and the reduction of air pollution.

I encourage you to not use the funding for natural gas, propane or diesel vehicles. Further dependence on fossil fuels means more pollution. Only a transition to electric vehicles and investment in EV infrastructure will put us on the road to a 100% clean transportation sector in North Carolina.

Sincerely,

Lee Rouse
5111 Meadowbrook Drive
Trent Woods, NC 28562
tlrouse@gmail.com
(252) 349-0199

This message was sent by KnowWho, as a service provider only, on behalf of the individual noted in the sender information.

From: Nathan Sabo (gdhog79@yahoo.com) Sent You a Personal Message
To: [daq.NC_VWGrants](#)
Subject: [External] Use Volkswagen funds to electrify NC transportation
Date: Tuesday, December 05, 2017 7:55:46 PM

CAUTION: External email. Do not click links or open attachments unless verified. Send all suspicious email as an attachment to report.spam@nc.gov.

Dear Division of Air Quality,

I am writing to urge DEQ to wisely invest the \$92 million in Volkswagen settlement funds in electric vehicles and infrastructure. Taking advantage of these funds to jumpstart the electrification of North Carolina's transportation sector will mean less money sent out of state for petroleum, more in-state jobs, and cleaner air.

Specifically, I recommend that DEQ allocate the maximum allowable amount (15%) of the funds for electric vehicle charging infrastructure and installations. And I encourage DEQ to prioritize electric vehicles and buses for replacement whenever possible with the other 85% of the settlement funds. Doing so will maximize the local economic impact and the reduction of air pollution.

I encourage you to not use the funding for natural gas, propane or diesel vehicles. Further dependence on fossil fuels means more pollution. Only a transition to electric vehicles and investment in EV infrastructure will put us on the road to a 100% clean transportation sector in North Carolina.

Sincerely,

Nathan Sabo
46 Pinehurst Rd
Asheville, NC 28808
gdhog79@yahoo.com
(828) 301-8228

This message was sent by KnowWho, as a service provider only, on behalf of the individual noted in the sender information.

From: Steve Roberts (poetsroberts@yahoo.com) Sent You a Personal Message
To: [daq.NC_VWGrants](#)
Subject: [External] Use Volkswagen funds to electrify NC transportation
Date: Tuesday, December 05, 2017 7:54:00 PM

CAUTION: External email. Do not click links or open attachments unless verified. Send all suspicious email as an attachment to report.spam@nc.gov.

Dear Division of Air Quality,

I am writing to urge DEQ to wisely invest the \$92 million in Volkswagen settlement funds in electric vehicles and infrastructure. Taking advantage of these funds to jumpstart the electrification of North Carolina's transportation sector will mean less money sent out of state for petroleum, more in-state jobs, and cleaner air.

Specifically, I recommend that DEQ allocate the maximum allowable amount (15%) of the funds for electric vehicle charging infrastructure and installations. And I encourage DEQ to prioritize electric vehicles and buses for replacement whenever possible with the other 85% of the settlement funds. Doing so will maximize the local economic impact and the reduction of air pollution.

I encourage you to not use the funding for natural gas, propane or diesel vehicles. Further dependence on fossil fuels means more pollution. Only a transition to electric vehicles and investment in EV infrastructure will put us on the road to a 100% clean transportation sector in North Carolina.

Sincerely,

Steve Roberts
202 s 3rd st apt 10
Wilmington, NC 28401
poetsroberts@yahoo.com
(910) 619-3675

This message was sent by KnowWho, as a service provider only, on behalf of the individual noted in the sender information.

From: August PRESCHLE (exploor@triad.rr.com) Sent You a Personal Message
To: [daq.NC_VWGrants](#)
Subject: [External] Use Volkswagen funds to electrify NC transportation
Date: Tuesday, December 05, 2017 7:53:46 PM

CAUTION: External email. Do not click links or open attachments unless verified. Send all suspicious email as an attachment to report.spam@nc.gov.

Dear Division of Air Quality,

I am writing to urge DEQ to wisely invest the \$92 million in Volkswagen settlement funds in electric vehicles and infrastructure. Taking advantage of these funds to jumpstart the electrification of North Carolina's transportation sector will mean less money sent out of state for petroleum, more in-state jobs, and cleaner air.

Specifically, I recommend that DEQ allocate the maximum allowable amount (15%) of the funds for electric vehicle charging infrastructure and installations. And I encourage DEQ to prioritize electric vehicles and buses for replacement whenever possible with the other 85% of the settlement funds. Doing so will maximize the local economic impact and the reduction of air pollution.

I encourage you to not use the funding for natural gas, propane or diesel vehicles. Further dependence on fossil fuels means more pollution. Only a transition to electric vehicles and investment in EV infrastructure will put us on the road to a 100% clean transportation sector in North Carolina.

Sincerely,

August PRESCHLE
1023 Feldspar Lane
Lewisville, NC 27023
exploor@triad.rr.com
(336) 201-2026

This message was sent by KnowWho, as a service provider only, on behalf of the individual noted in the sender information.

From: Jan Ross (janross999@gmail.com) Sent You a Personal Message
To: [daq.NC_VWGrants](#)
Subject: [External] Use Volkswagen funds to electrify NC transportation
Date: Tuesday, December 05, 2017 7:53:24 PM

CAUTION: External email. Do not click links or open attachments unless verified. Send all suspicious email as an attachment to report.spam@nc.gov.

Dear Division of Air Quality,

I am writing to urge DEQ to wisely invest the \$92 million in Volkswagen settlement funds in electric vehicles and infrastructure. Taking advantage of these funds to jumpstart the electrification of North Carolina's transportation sector will mean less money sent out of state for petroleum, more in-state jobs, and cleaner air.

Specifically, I recommend that DEQ allocate the maximum allowable amount (15%) of the funds for electric vehicle charging infrastructure and installations. And I encourage DEQ to prioritize electric vehicles and buses for replacement whenever possible with the other 85% of the settlement funds. Doing so will maximize the local economic impact and the reduction of air pollution.

I encourage you to not use the funding for natural gas, propane or diesel vehicles. Further dependence on fossil fuels means more pollution. Only a transition to electric vehicles and investment in EV infrastructure will put us on the road to a 100% clean transportation sector in North Carolina.

Sincerely,

Jan Ross
251 Jim's Branch
Jan, NC 28778
janross999@gmail.com
(828) 575-6298

This message was sent by KnowWho, as a service provider only, on behalf of the individual noted in the sender information.

From: Christine Drea (cdrea@duke.edu) Sent You a Personal Message
To: [daq.NC_VWGrants](#)
Subject: [External] Use Volkswagen funds to electrify NC transportation
Date: Tuesday, December 05, 2017 7:52:59 PM

CAUTION: External email. Do not click links or open attachments unless verified. Send all suspicious email as an attachment to report.spam@nc.gov.

Dear Division of Air Quality,

I am writing to urge DEQ to wisely invest the \$92 million in Volkswagen settlement funds in electric vehicles and infrastructure. Taking advantage of these funds to jumpstart the electrification of North Carolina's transportation sector will mean less money sent out of state for petroleum, more in-state jobs, and cleaner air.

Specifically, I recommend that DEQ allocate the maximum allowable amount (15%) of the funds for electric vehicle charging infrastructure and installations. And I encourage DEQ to prioritize electric vehicles and buses for replacement whenever possible with the other 85% of the settlement funds. Doing so will maximize the local economic impact and the reduction of air pollution.

I encourage you to not use the funding for natural gas, propane or diesel vehicles. Further dependence on fossil fuels means more pollution. Only a transition to electric vehicles and investment in EV infrastructure will put us on the road to a 100% clean transportation sector in North Carolina.

Sincerely,

Christine Drea
1709 Rosedale Ave
Durham, NC 27707
cdrea@duke.edu
(919) 401-5901

This message was sent by KnowWho, as a service provider only, on behalf of the individual noted in the sender information.

From: Manuel Medeiros (mannymed34@gmail.com) Sent You a Personal Message
To: [daq.NC_VWGrants](#)
Subject: [External] Use Volkswagen funds to electrify NC transportation
Date: Tuesday, December 05, 2017 7:45:12 PM

CAUTION: External email. Do not click links or open attachments unless verified. Send all suspicious email as an attachment to report.spam@nc.gov.

Dear Division of Air Quality,

I am writing to urge DEQ to wisely invest the \$92 million in Volkswagen settlement funds in electric vehicles and infrastructure. Taking advantage of these funds to jumpstart the electrification of North Carolina's transportation sector will mean less money sent out of state for petroleum, more in-state jobs, and cleaner air.

Specifically, I recommend that DEQ allocate the maximum allowable amount (15%) of the funds for electric vehicle charging infrastructure and installations. And I encourage DEQ to prioritize electric vehicles and buses for replacement whenever possible with the other 85% of the settlement funds. Doing so will maximize the local economic impact and the reduction of air pollution.

I encourage you to not use the funding for natural gas, propane or diesel vehicles. Further dependence on fossil fuels means more pollution. Only a transition to electric vehicles and investment in EV infrastructure will put us on the road to a 100% clean transportation sector in North Carolina.

Sincerely,

Manuel Medeiros
106 Dunraven Ct
Matthews, NC 28104
mannymed34@gmail.com
(828) 707-1447

This message was sent by KnowWho, as a service provider only, on behalf of the individual noted in the sender information.

From: shannon simpson (thirteenmoons13@yahoo.com) Sent You a Personal Message
To: [daq.NC_VWGrants](#)
Subject: [External] Use Volkswagen funds to electrify NC transportation
Date: Tuesday, December 05, 2017 7:44:39 PM

CAUTION: External email. Do not click links or open attachments unless verified. Send all suspicious email as an attachment to report.spam@nc.gov.

Dear Division of Air Quality,

I am writing to urge DEQ to wisely invest the \$92 million in Volkswagen settlement funds in electric vehicles and infrastructure. Taking advantage of these funds to jumpstart the electrification of North Carolina's transportation sector will mean less money sent out of state for petroleum, more in-state jobs, and cleaner air.

Specifically, I recommend that DEQ allocate the maximum allowable amount (15%) of the funds for electric vehicle charging infrastructure and installations. And I encourage DEQ to prioritize electric vehicles and buses for replacement whenever possible with the other 85% of the settlement funds. Doing so will maximize the local economic impact and the reduction of air pollution.

I encourage you to not use the funding for natural gas, propane or diesel vehicles. Further dependence on fossil fuels means more pollution. Only a transition to electric vehicles and investment in EV infrastructure will put us on the road to a 100% clean transportation sector in North Carolina.

Sincerely,

shannon simpson
87 maple drive
asheville, NC 28805
thirteenmoons13@yahoo.com
(304) 573-5613

This message was sent by KnowWho, as a service provider only, on behalf of the individual noted in the sender information.

From: Maria Kelly (mariadelcarmenkelly@gmail.com) Sent You a Personal Message
To: [daq.NC_VWGrants](#)
Subject: [External] Use Volkswagen funds to electrify NC transportation
Date: Tuesday, December 05, 2017 7:42:05 PM

CAUTION: External email. Do not click links or open attachments unless verified. Send all suspicious email as an attachment to report.spam@nc.gov.

Dear Division of Air Quality,

I am writing to urge DEQ to wisely invest the \$92 million in Volkswagen settlement funds in electric vehicles and infrastructure. Taking advantage of these funds to jumpstart the electrification of North Carolina's transportation sector will mean less money sent out of state for petroleum, more in-state jobs, and cleaner air.

Specifically, I recommend that DEQ allocate the maximum allowable amount (15%) of the funds for electric vehicle charging infrastructure and installations. And I encourage DEQ to prioritize electric vehicles and buses for replacement whenever possible with the other 85% of the settlement funds. Doing so will maximize the local economic impact and the reduction of air pollution.

I encourage you to not use the funding for natural gas, propane or diesel vehicles. Further dependence on fossil fuels means more pollution. Only a transition to electric vehicles and investment in EV infrastructure will put us on the road to a 100% clean transportation sector in North Carolina.

Sincerely,

Maria Kelly
2416 Alpine Road
Durham, NC 27707
mariadelcarmenkelly@gmail.com
(919) 259-2724

This message was sent by KnowWho, as a service provider only, on behalf of the individual noted in the sender information.

From: Bruce Morgen (editor@juno.com) Sent You a Personal Message
To: daq.NC_VWGrants
Subject: [External] Use Volkswagen funds to electrify NC transportation
Date: Tuesday, December 05, 2017 7:35:12 PM

CAUTION: External email. Do not click links or open attachments unless verified. Send all suspicious email as an attachment to report.spam@nc.gov.

Dear Division of Air Quality,

I am writing to urge DEQ to wisely invest the \$92 million in Volkswagen settlement funds in electric vehicles and infrastructure. Taking advantage of these funds to jumpstart the electrification of North Carolina's transportation sector will mean less money sent out of state for petroleum, more in-state jobs, and cleaner air.

Specifically, I recommend that DEQ allocate the maximum allowable amount (15%) of the funds for electric vehicle charging infrastructure and installations. And I encourage DEQ to prioritize electric vehicles and buses for replacement whenever possible with the other 85% of the settlement funds. Doing so will maximize the local economic impact and the reduction of air pollution.

I encourage you to not use the funding for natural gas, propane or diesel vehicles. Further dependence on fossil fuels means more pollution. Only a transition to electric vehicles and investment in EV infrastructure will put us on the road to a 100% clean transportation sector in North Carolina.

Sincerely,

Bruce Morgen
300 Long Shoals Road Apartment 4F
Arden, NC 28704
editor@juno.com
(828) 318-8616

This message was sent by KnowWho, as a service provider only, on behalf of the individual noted in the sender information.

From: Robert BURGER (joeburger42@gmail.com) Sent You a Personal Message
To: [daq.NC_VWGrants](#)
Subject: [External] Use Volkswagen funds to electrify NC transportation
Date: Tuesday, December 05, 2017 7:35:00 PM

CAUTION: External email. Do not click links or open attachments unless verified. Send all suspicious email as an attachment to report.spam@nc.gov.

Dear Division of Air Quality,

I am writing to urge DEQ to wisely invest the \$92 million in Volkswagen settlement funds in electric vehicles and infrastructure. Taking advantage of these funds to jumpstart the electrification of North Carolina's transportation sector will mean less money sent out of state for petroleum, more in-state jobs, and cleaner air.

Specifically, I recommend that DEQ allocate the maximum allowable amount (15%) of the funds for electric vehicle charging infrastructure and installations. And I encourage DEQ to prioritize electric vehicles and buses for replacement whenever possible with the other 85% of the settlement funds. Doing so will maximize the local economic impact and the reduction of air pollution.

I encourage you to not use the funding for natural gas, propane or diesel vehicles. Further dependence on fossil fuels means more pollution. Only a transition to electric vehicles and investment in EV infrastructure will put us on the road to a 100% clean transportation sector in North Carolina.

Sincerely,

Robert BURGER
1942 Norwood St SW
JOE, NC 28469
joeburger42@gmail.com
(910) 575-4451

This message was sent by KnowWho, as a service provider only, on behalf of the individual noted in the sender information.

From: Richard Pigossi (rpigossi@mac.com) Sent You a Personal Message
To: [daq.NC_VWGrants](#)
Subject: [External] Use Volkswagen funds to electrify NC transportation
Date: Tuesday, December 05, 2017 7:35:00 PM

CAUTION: External email. Do not click links or open attachments unless verified. Send all suspicious email as an attachment to report.spam@nc.gov.

Dear Division of Air Quality,

I am writing to urge DEQ to wisely invest the \$92 million in Volkswagen settlement funds in electric vehicles and infrastructure. Taking advantage of these funds to jumpstart the electrification of North Carolina's transportation sector will mean less money sent out of state for petroleum, more in-state jobs, and cleaner air.

Specifically, I recommend that DEQ allocate the maximum allowable amount (15%) of the funds for electric vehicle charging infrastructure and installations. And I encourage DEQ to prioritize electric vehicles and buses for replacement whenever possible with the other 85% of the settlement funds. Doing so will maximize the local economic impact and the reduction of air pollution.

I encourage you to not use the funding for natural gas, propane or diesel vehicles. Further dependence on fossil fuels means more pollution. Only a transition to electric vehicles and investment in EV infrastructure will put us on the road to a 100% clean transportation sector in North Carolina.

Sincerely,

Richard Pigossi
14 Cedarcliff Road
Richard, NC 28803
rpigossi@mac.com
(828) 398-0493

This message was sent by KnowWho, as a service provider only, on behalf of the individual noted in the sender information.

From: Kyle Cory (kylecory@gmail.com) Sent You a Personal Message
To: [daq.NC_VWGrants](#)
Subject: [External] Use Volkswagen funds to electrify NC transportation
Date: Tuesday, December 05, 2017 7:26:14 PM

CAUTION: External email. Do not click links or open attachments unless verified. Send all suspicious email as an attachment to report.spam@nc.gov.

Dear Division of Air Quality,

I am writing to urge DEQ to wisely invest the \$92 million in Volkswagen settlement funds in electric vehicles and infrastructure. Taking advantage of these funds to jumpstart the electrification of North Carolina's transportation sector will mean less money sent out of state for petroleum, more in-state jobs, and cleaner air.

Specifically, I recommend that DEQ allocate the maximum allowable amount (15%) of the funds for electric vehicle charging infrastructure and installations. And I encourage DEQ to prioritize electric vehicles and buses for replacement whenever possible with the other 85% of the settlement funds. Doing so will maximize the local economic impact and the reduction of air pollution.

I encourage you to not use the funding for natural gas, propane or diesel vehicles. Further dependence on fossil fuels means more pollution. Only a transition to electric vehicles and investment in EV infrastructure will put us on the road to a 100% clean transportation sector in North Carolina.

Sincerely,

Kyle Cory
1001 Ruby St
Kyle, NC 27704
kylecory@gmail.com
(919) 360-6649

This message was sent by KnowWho, as a service provider only, on behalf of the individual noted in the sender information.

From: James Walsh (jaywalsh@thistle-cottage.com) Sent You a Personal Message
To: [daq.NC_VWGrants](#)
Subject: [External] Use Volkswagen funds to electrify NC transportation
Date: Tuesday, December 05, 2017 7:22:45 PM

CAUTION: External email. Do not click links or open attachments unless verified. Send all suspicious email as an attachment to report.spam@nc.gov.

Dear Division of Air Quality,

I am writing to urge DEQ to wisely invest the \$92 million in Volkswagen settlement funds in electric vehicles and infrastructure. Taking advantage of these funds to jumpstart the electrification of North Carolina's transportation sector will mean less money sent out of state for petroleum, more in-state jobs, and cleaner air.

Specifically, I recommend that DEQ allocate the maximum allowable amount (15%) of the funds for electric vehicle charging infrastructure and installations. And I encourage DEQ to prioritize electric vehicles and buses for replacement whenever possible with the other 85% of the settlement funds. Doing so will maximize the local economic impact and the reduction of air pollution.

I encourage you to not use the funding for natural gas, propane or diesel vehicles. Further dependence on fossil fuels means more pollution. Only a transition to electric vehicles and investment in EV infrastructure will put us on the road to a 100% clean transportation sector in North Carolina.

Sincerely,

James Walsh
P. O. Box 246, None
Morganton, NC 28680
jaywalsh@thistle-cottage.com
(828) 390-6024

This message was sent by KnowWho, as a service provider only, on behalf of the individual noted in the sender information.

From: Bob Cherry (bcherry001@gmail.com) Sent You a Personal Message
To: [daq.NC_VWGrants](#)
Subject: [External] Use Volkswagen funds to electrify NC transportation
Date: Tuesday, December 05, 2017 7:22:08 PM

CAUTION: External email. Do not click links or open attachments unless verified. Send all suspicious email as an attachment to report.spam@nc.gov.

Dear Division of Air Quality,

I am writing to urge DEQ to wisely invest the \$92 million in Volkswagen settlement funds in electric vehicles and infrastructure. Taking advantage of these funds to jumpstart the electrification of North Carolina's transportation sector will mean less money sent out of state for petroleum, more in-state jobs, and cleaner air.

Specifically, I recommend that DEQ allocate the maximum allowable amount (15%) of the funds for electric vehicle charging infrastructure and installations. And I encourage DEQ to prioritize electric vehicles and buses for replacement whenever possible with the other 85% of the settlement funds. Doing so will maximize the local economic impact and the reduction of air pollution.

I encourage you to not use the funding for natural gas, propane or diesel vehicles. Further dependence on fossil fuels means more pollution. Only a transition to electric vehicles and investment in EV infrastructure will put us on the road to a 100% clean transportation sector in North Carolina.

Sincerely,

Bob Cherry
301 Perkins St.
Boone, NC 28607
bcherry001@gmail.com
(800) 555-1234

This message was sent by KnowWho, as a service provider only, on behalf of the individual noted in the sender information.

From: Robert Kitteringham (bob.kitteringham@me.com) Sent You a Personal Message
To: [daq.NC_VWGrants](#)
Subject: [External] Use Volkswagen funds to electrify NC transportation
Date: Tuesday, December 05, 2017 7:20:35 PM

CAUTION: External email. Do not click links or open attachments unless verified. Send all suspicious email as an attachment to report.spam@nc.gov.

Dear Division of Air Quality,

I am writing to urge DEQ to wisely invest the \$92 million in Volkswagen settlement funds in electric vehicles and infrastructure. Taking advantage of these funds to jumpstart the electrification of North Carolina's transportation sector will mean less money sent out of state for petroleum, more in-state jobs, and cleaner air.

Specifically, I recommend that DEQ allocate the maximum allowable amount (15%) of the funds for electric vehicle charging infrastructure and installations. And I encourage DEQ to prioritize electric vehicles and buses for replacement whenever possible with the other 85% of the settlement funds. Doing so will maximize the local economic impact and the reduction of air pollution.

I encourage you to not use the funding for natural gas, propane or diesel vehicles. Further dependence on fossil fuels means more pollution. Only a transition to electric vehicles and investment in EV infrastructure will put us on the road to a 100% clean transportation sector in North Carolina.

Sincerely,

Robert Kitteringham
1120 Real Quiet Lane
Robert, NC 28173
bob.kitteringham@me.com
(704) 243-0952

This message was sent by KnowWho, as a service provider only, on behalf of the individual noted in the sender information.

From: Edie Simpson (mailedie@aol.com) Sent You a Personal Message
To: [daq.NC_VWGrants](#)
Subject: [External] Use Volkswagen funds to electrify NC transportation
Date: Tuesday, December 05, 2017 7:20:14 PM

CAUTION: External email. Do not click links or open attachments unless verified. Send all suspicious email as an attachment to report.spam@nc.gov.

Dear Division of Air Quality,

I am writing to urge DEQ to wisely invest the \$92 million in Volkswagen settlement funds in electric vehicles and infrastructure. Taking advantage of these funds to jumpstart the electrification of North Carolina's transportation sector will mean less money sent out of state for petroleum, more in-state jobs, and cleaner air.

Specifically, I recommend that DEQ allocate the maximum allowable amount (15%) of the funds for electric vehicle charging infrastructure and installations. And I encourage DEQ to prioritize electric vehicles and buses for replacement whenever possible with the other 85% of the settlement funds. Doing so will maximize the local economic impact and the reduction of air pollution.

I encourage you to not use the funding for natural gas, propane or diesel vehicles. Further dependence on fossil fuels means more pollution. Only a transition to electric vehicles and investment in EV infrastructure will put us on the road to a 100% clean transportation sector in North Carolina.

Sincerely,

Edie Simpson
15 Springdale Rd
Asheville, NC 28805
mailedie@aol.com
(828) 505-3393

This message was sent by KnowWho, as a service provider only, on behalf of the individual noted in the sender information.

From: Christie Cantrell (cantrellchristie@yahoo.com) Sent You a Personal Message
To: [daq.NC_VWGrants](#)
Subject: [External] Use Volkswagen funds to electrify NC transportation
Date: Tuesday, December 05, 2017 7:20:13 PM

CAUTION: External email. Do not click links or open attachments unless verified. Send all suspicious email as an attachment to report.spam@nc.gov.

Dear Division of Air Quality,

I am writing to urge DEQ to wisely invest the \$92 million in Volkswagen settlement funds in electric vehicles and infrastructure. Taking advantage of these funds to jumpstart the electrification of North Carolina's transportation sector will mean less money sent out of state for petroleum, more in-state jobs, and cleaner air.

Specifically, I recommend that DEQ allocate the maximum allowable amount (15%) of the funds for electric vehicle charging infrastructure and installations. And I encourage DEQ to prioritize electric vehicles and buses for replacement whenever possible with the other 85% of the settlement funds. Doing so will maximize the local economic impact and the reduction of air pollution.

I encourage you to not use the funding for natural gas, propane or diesel vehicles. Further dependence on fossil fuels means more pollution. Only a transition to electric vehicles and investment in EV infrastructure will put us on the road to a 100% clean transportation sector in North Carolina.

Sincerely,

Christie Cantrell
2515 Crescent forest Drive
Christie, NC 27610
cantrellchristie@yahoo.com
(919) 436-9630

This message was sent by KnowWho, as a service provider only, on behalf of the individual noted in the sender information.

From: Ellen Fallon (ellenmfallon@gmail.com) Sent You a Personal Message
To: [daq.NC_VWGrants](#)
Subject: [External] Use Volkswagen funds to electrify NC transportation
Date: Tuesday, December 05, 2017 7:19:42 PM

CAUTION: External email. Do not click links or open attachments unless verified. Send all suspicious email as an attachment to report.spam@nc.gov.

Dear Division of Air Quality,

I am writing to urge DEQ to wisely invest the \$92 million in Volkswagen settlement funds in electric vehicles and infrastructure. Taking advantage of these funds to jumpstart the electrification of North Carolina's transportation sector will mean less money sent out of state for petroleum, more in-state jobs, and cleaner air.

Specifically, I recommend that DEQ allocate the maximum allowable amount (15%) of the funds for electric vehicle charging infrastructure and installations. And I encourage DEQ to prioritize electric vehicles and buses for replacement whenever possible with the other 85% of the settlement funds. Doing so will maximize the local economic impact and the reduction of air pollution.

I encourage you to not use the funding for natural gas, propane or diesel vehicles. Further dependence on fossil fuels means more pollution. Only a transition to electric vehicles and investment in EV infrastructure will put us on the road to a 100% clean transportation sector in North Carolina.

Sincerely,

Ellen Fallon
PO Box 1123,,
Carrboro, NC 27510
ellenmfallon@gmail.com
(919) 928-9517

This message was sent by KnowWho, as a service provider only, on behalf of the individual noted in the sender information.

From: William Garrard (pastorgarrard@hotmail.com) Sent You a Personal Message
To: [daq.NC_VWGrants](#)
Subject: [External] Use Volkswagen funds to electrify NC transportation
Date: Tuesday, December 05, 2017 7:18:47 PM

CAUTION: External email. Do not click links or open attachments unless verified. Send all suspicious email as an attachment to report.spam@nc.gov.

Dear Division of Air Quality,

I am writing to urge DEQ to wisely invest the \$92 million in Volkswagen settlement funds in electric vehicles and infrastructure. Taking advantage of these funds to jumpstart the electrification of North Carolina's transportation sector will mean less money sent out of state for petroleum, more in-state jobs, and cleaner air.

Specifically, I recommend that DEQ allocate the maximum allowable amount (15%) of the funds for electric vehicle charging infrastructure and installations. And I encourage DEQ to prioritize electric vehicles and buses for replacement whenever possible with the other 85% of the settlement funds. Doing so will maximize the local economic impact and the reduction of air pollution.

I encourage you to not use the funding for natural gas, propane or diesel vehicles. Further dependence on fossil fuels means more pollution. Only a transition to electric vehicles and investment in EV infrastructure will put us on the road to a 100% clean transportation sector in North Carolina.

Sincerely,

William Garrard
472 22nd Avenue NE
Hickory, NC 28601
pastorgarrard@hotmail.com
(828) 962-7566

This message was sent by KnowWho, as a service provider only, on behalf of the individual noted in the sender information.

From: Shirley Ware-Gully (swaregully@yahoo.com) Sent You a Personal Message
To: [daq.NC_VWGrants](#)
Subject: [External] Use Volkswagen funds to electrify NC transportation
Date: Tuesday, December 05, 2017 7:16:35 PM

CAUTION: External email. Do not click links or open attachments unless verified. Send all suspicious email as an attachment to report.spam@nc.gov.

Dear Division of Air Quality,

I am writing to urge DEQ to wisely invest the \$92 million in Volkswagen settlement funds in electric vehicles and infrastructure. Taking advantage of these funds to jumpstart the electrification of North Carolina's transportation sector will mean less money sent out of state for petroleum, more in-state jobs, and cleaner air.

Specifically, I recommend that DEQ allocate the maximum allowable amount (15%) of the funds for electric vehicle charging infrastructure and installations. And I encourage DEQ to prioritize electric vehicles and buses for replacement whenever possible with the other 85% of the settlement funds. Doing so will maximize the local economic impact and the reduction of air pollution.

I encourage you to not use the funding for natural gas, propane or diesel vehicles. Further dependence on fossil fuels means more pollution. Only a transition to electric vehicles and investment in EV infrastructure will put us on the road to a 100% clean transportation sector in North Carolina.

Sincerely,

Shirley Ware-Gully
103 Bellshill Ct, Shirl
Cary, NC 27513
swaregully@yahoo.com
(913) 800-1219

This message was sent by KnowWho, as a service provider only, on behalf of the individual noted in the sender information.

From: Cindy Moore (vegansprout58@gmail.com) Sent You a Personal Message
To: [daq.NC_VWGrants](#)
Subject: [External] Use Volkswagen funds to electrify NC transportation
Date: Tuesday, December 05, 2017 7:15:13 PM

CAUTION: External email. Do not click links or open attachments unless verified. Send all suspicious email as an attachment to report.spam@nc.gov.

Dear Division of Air Quality,

I am writing to urge DEQ to wisely invest the \$92 million in Volkswagen settlement funds in electric vehicles and infrastructure. Taking advantage of these funds to jumpstart the electrification of North Carolina's transportation sector will mean less money sent out of state for petroleum, more in-state jobs, and cleaner air.

Specifically, I recommend that DEQ allocate the maximum allowable amount (15%) of the funds for electric vehicle charging infrastructure and installations. And I encourage DEQ to prioritize electric vehicles and buses for replacement whenever possible with the other 85% of the settlement funds. Doing so will maximize the local economic impact and the reduction of air pollution.

I encourage you to not use the funding for natural gas, propane or diesel vehicles. Further dependence on fossil fuels means more pollution. Only a transition to electric vehicles and investment in EV infrastructure will put us on the road to a 100% clean transportation sector in North Carolina.

Sincerely,

Cindy Moore
2113 holly drive
Wilmington, NC 28401
vegansprout58@gmail.com
(910) 352-6754

This message was sent by KnowWho, as a service provider only, on behalf of the individual noted in the sender information.

From: Deborah Bryant (deborahbryanthandwoven@gmail.com) Sent You a Personal Message
To: daq.NC_VWGrants
Subject: [External] Use Volkswagen funds to electrify NC transportation
Date: Tuesday, December 05, 2017 7:13:46 PM

CAUTION: External email. Do not click links or open attachments unless verified. Send all suspicious email as an attachment to report.spam@nc.gov.

Dear Division of Air Quality,

I am writing to urge DEQ to wisely invest the \$92 million in Volkswagen settlement funds in electric vehicles and infrastructure. Taking advantage of these funds to jumpstart the electrification of North Carolina's transportation sector will mean less money sent out of state for petroleum, more in-state jobs, and cleaner air.

Specifically, I recommend that DEQ allocate the maximum allowable amount (15%) of the funds for electric vehicle charging infrastructure and installations. And I encourage DEQ to prioritize electric vehicles and buses for replacement whenever possible with the other 85% of the settlement funds. Doing so will maximize the local economic impact and the reduction of air pollution.

I encourage you to not use the funding for natural gas, propane or diesel vehicles. Further dependence on fossil fuels means more pollution. Only a transition to electric vehicles and investment in EV infrastructure will put us on the road to a 100% clean transportation sector in North Carolina.

Sincerely,

Deborah Bryant
PO Box 1296
Cashiers, NC 28717
deborahbryanthandwoven@gmail.com
(828) 507-6235

This message was sent by KnowWho, as a service provider only, on behalf of the individual noted in the sender information.

From: Ann Wood (ann.wood@rocketmail.com) Sent You a Personal Message
To: [daq.NC_VWGrants](#)
Subject: [External] Use Volkswagen funds to electrify NC transportation
Date: Tuesday, December 05, 2017 7:13:14 PM

CAUTION: External email. Do not click links or open attachments unless verified. Send all suspicious email as an attachment to report.spam@nc.gov.

Dear Division of Air Quality,

I am writing to urge DEQ to wisely invest the \$92 million in Volkswagen settlement funds in electric vehicles and infrastructure. Taking advantage of these funds to jumpstart the electrification of North Carolina's transportation sector will mean less money sent out of state for petroleum, more in-state jobs, and cleaner air.

Specifically, I recommend that DEQ allocate the maximum allowable amount (15%) of the funds for electric vehicle charging infrastructure and installations. And I encourage DEQ to prioritize electric vehicles and buses for replacement whenever possible with the other 85% of the settlement funds. Doing so will maximize the local economic impact and the reduction of air pollution.

I encourage you to not use the funding for natural gas, propane or diesel vehicles. Further dependence on fossil fuels means more pollution. Only a transition to electric vehicles and investment in EV infrastructure will put us on the road to a 100% clean transportation sector in North Carolina.

Sincerely,

Ann Wood
4405 roller ct
Raleigh, NC 27604
ann.wood@rocketmail.com
(919) 669-9094

This message was sent by KnowWho, as a service provider only, on behalf of the individual noted in the sender information.

From: Daniel Sherfey (ddsherfey@gmail.com) Sent You a Personal Message
To: [daq.NC_VWGrants](#)
Subject: [External] Use Volkswagen funds to electrify NC transportation
Date: Tuesday, December 05, 2017 7:12:40 PM

CAUTION: External email. Do not click links or open attachments unless verified. Send all suspicious email as an attachment to report.spam@nc.gov.

Dear Division of Air Quality,

I am writing to urge DEQ to wisely invest the \$92 million in Volkswagen settlement funds in electric vehicles and infrastructure. Taking advantage of these funds to jumpstart the electrification of North Carolina's transportation sector will mean less money sent out of state for petroleum, more in-state jobs, and cleaner air.

Specifically, I recommend that DEQ allocate the maximum allowable amount (15%) of the funds for electric vehicle charging infrastructure and installations. And I encourage DEQ to prioritize electric vehicles and buses for replacement whenever possible with the other 85% of the settlement funds. Doing so will maximize the local economic impact and the reduction of air pollution.

I encourage you to not use the funding for natural gas, propane or diesel vehicles. Further dependence on fossil fuels means more pollution. Only a transition to electric vehicles and investment in EV infrastructure will put us on the road to a 100% clean transportation sector in North Carolina.

Sincerely,

Daniel Sherfey
2215B Brookville Dr
Greenville, NC 27834
ddsherfey@gmail.com
(914) 393-4938

This message was sent by KnowWho, as a service provider only, on behalf of the individual noted in the sender information.

From: Heide Coppotelli (goodshepherd@comporium.net) Sent You a Personal Message
To: [daq.NC_VWGrants](#)
Subject: [External] Use Volkswagen funds to electrify NC transportation
Date: Tuesday, December 05, 2017 7:12:39 PM

CAUTION: External email. Do not click links or open attachments unless verified. Send all suspicious email as an attachment to report.spam@nc.gov.

Dear Division of Air Quality,

I am writing to urge DEQ to wisely invest the \$92 million in Volkswagen settlement funds in electric vehicles and infrastructure. Taking advantage of these funds to jumpstart the electrification of North Carolina's transportation sector will mean less money sent out of state for petroleum, more in-state jobs, and cleaner air.

Specifically, I recommend that DEQ allocate the maximum allowable amount (15%) of the funds for electric vehicle charging infrastructure and installations. And I encourage DEQ to prioritize electric vehicles and buses for replacement whenever possible with the other 85% of the settlement funds. Doing so will maximize the local economic impact and the reduction of air pollution.

I encourage you to not use the funding for natural gas, propane or diesel vehicles. Further dependence on fossil fuels means more pollution. Only a transition to electric vehicles and investment in EV infrastructure will put us on the road to a 100% clean transportation sector in North Carolina.

Sincerely,

Heide Coppotelli
383 Seldon Emerson Road
Cedar Mountain, NC 28718
goodshepherd@comporium.net
(828) 884-4673

This message was sent by KnowWho, as a service provider only, on behalf of the individual noted in the sender information.

From: andrew/bonnie tangalos (tangalos@me.com) Sent You a Personal Message
To: [daq.NC_VWGrants](#)
Subject: [External] Use Volkswagen funds to electrify NC transportation
Date: Tuesday, December 05, 2017 7:12:34 PM

CAUTION: External email. Do not click links or open attachments unless verified. Send all suspicious email as an attachment to report.spam@nc.gov.

Dear Division of Air Quality,

I am writing to urge DEQ to wisely invest the \$92 million in Volkswagen settlement funds in electric vehicles and infrastructure. Taking advantage of these funds to jumpstart the electrification of North Carolina's transportation sector will mean less money sent out of state for petroleum, more in-state jobs, and cleaner air.

Specifically, I recommend that DEQ allocate the maximum allowable amount (15%) of the funds for electric vehicle charging infrastructure and installations. And I encourage DEQ to prioritize electric vehicles and buses for replacement whenever possible with the other 85% of the settlement funds. Doing so will maximize the local economic impact and the reduction of air pollution.

I encourage you to not use the funding for natural gas, propane or diesel vehicles. Further dependence on fossil fuels means more pollution. Only a transition to electric vehicles and investment in EV infrastructure will put us on the road to a 100% clean transportation sector in North Carolina.

Sincerely,

andrew/bonnie tangalos
812 cherokee road
charlotte, NC 28207
tangalos@me.com
(802) 999-4430

This message was sent by KnowWho, as a service provider only, on behalf of the individual noted in the sender information.

From: Ami Bowen (ami@bowenimagery.com) Sent You a Personal Message
To: daq.NC_VWGrants
Subject: [External] Use Volkswagen funds to electrify NC transportation
Date: Tuesday, December 05, 2017 7:09:45 PM

CAUTION: External email. Do not click links or open attachments unless verified. Send all suspicious email as an attachment to report.spam@nc.gov.

Dear Division of Air Quality,

I am writing to urge DEQ to wisely invest the \$92 million in Volkswagen settlement funds in electric vehicles and infrastructure. Taking advantage of these funds to jumpstart the electrification of North Carolina's transportation sector will mean less money sent out of state for petroleum, more in-state jobs, and cleaner air.

Specifically, I recommend that DEQ allocate the maximum allowable amount (15%) of the funds for electric vehicle charging infrastructure and installations. And I encourage DEQ to prioritize electric vehicles and buses for replacement whenever possible with the other 85% of the settlement funds. Doing so will maximize the local economic impact and the reduction of air pollution.

I encourage you to not use the funding for natural gas, propane or diesel vehicles. Further dependence on fossil fuels means more pollution. Only a transition to electric vehicles and investment in EV infrastructure will put us on the road to a 100% clean transportation sector in North Carolina.

Sincerely,

Ami Bowen
95 cartwright drive
Waynesville, NC 28786
ami@bowenimagery.com
(727) 480-4162

This message was sent by KnowWho, as a service provider only, on behalf of the individual noted in the sender information.

From: Art Smoker (ansmoker@gmail.com) Sent You a Personal Message
To: [daq.NC_VWGrants](#)
Subject: [External] Use Volkswagen funds to electrify NC transportation
Date: Tuesday, December 05, 2017 7:09:25 PM

CAUTION: External email. Do not click links or open attachments unless verified. Send all suspicious email as an attachment to report.spam@nc.gov.

Dear Division of Air Quality,

I am writing to urge DEQ to wisely invest the \$92 million in Volkswagen settlement funds in electric vehicles and infrastructure. Taking advantage of these funds to jumpstart the electrification of North Carolina's transportation sector will mean less money sent out of state for petroleum, more in-state jobs, and cleaner air.

Specifically, I recommend that DEQ allocate the maximum allowable amount (15%) of the funds for electric vehicle charging infrastructure and installations. And I encourage DEQ to prioritize electric vehicles and buses for replacement whenever possible with the other 85% of the settlement funds. Doing so will maximize the local economic impact and the reduction of air pollution.

I encourage you to not use the funding for natural gas, propane or diesel vehicles. Further dependence on fossil fuels means more pollution. Only a transition to electric vehicles and investment in EV infrastructure will put us on the road to a 100% clean transportation sector in North Carolina.

Sincerely,

Art Smoker
284 Arrowood Corner Rd.
Mars Hill, NC 28754
ansmoker@gmail.com
(828) 680-9695

This message was sent by KnowWho, as a service provider only, on behalf of the individual noted in the sender information.

From: Christy Jenkins (bamboo_marbles@hotmail.com) Sent You a Personal Message
To: [daq.NC_VWGrants](#)
Subject: [External] Use Volkswagen funds to electrify NC transportation
Date: Tuesday, December 05, 2017 7:09:01 PM

CAUTION: External email. Do not click links or open attachments unless verified. Send all suspicious email as an attachment to report.spam@nc.gov.

Dear Division of Air Quality,

I am writing to urge DEQ to wisely invest the \$92 million in Volkswagen settlement funds in electric vehicles and infrastructure. Taking advantage of these funds to jumpstart the electrification of North Carolina's transportation sector will mean less money sent out of state for petroleum, more in-state jobs, and cleaner air.

Specifically, I recommend that DEQ allocate the maximum allowable amount (15%) of the funds for electric vehicle charging infrastructure and installations. And I encourage DEQ to prioritize electric vehicles and buses for replacement whenever possible with the other 85% of the settlement funds. Doing so will maximize the local economic impact and the reduction of air pollution.

I encourage you to not use the funding for natural gas, propane or diesel vehicles. Further dependence on fossil fuels means more pollution. Only a transition to electric vehicles and investment in EV infrastructure will put us on the road to a 100% clean transportation sector in North Carolina.

Sincerely,

Christy Jenkins
239 riverwood drive
Hertford, NC 27944
bamboo_marbles@hotmail.com
(252) 339-2032

This message was sent by KnowWho, as a service provider only, on behalf of the individual noted in the sender information.

From: Judy Smith (jsnorkel23@gmail.com) Sent You a Personal Message
To: [daq.NC_VWGrants](#)
Subject: [External] Use Volkswagen funds to electrify NC transportation
Date: Tuesday, December 05, 2017 7:09:00 PM

CAUTION: External email. Do not click links or open attachments unless verified. Send all suspicious email as an attachment to report.spam@nc.gov.

Dear Division of Air Quality,

I am writing to urge DEQ to wisely invest the \$92 million in Volkswagen settlement funds in electric vehicles and infrastructure. Taking advantage of these funds to jumpstart the electrification of North Carolina's transportation sector will mean less money sent out of state for petroleum, more in-state jobs, and cleaner air.

Specifically, I recommend that DEQ allocate the maximum allowable amount (15%) of the funds for electric vehicle charging infrastructure and installations. And I encourage DEQ to prioritize electric vehicles and buses for replacement whenever possible with the other 85% of the settlement funds. Doing so will maximize the local economic impact and the reduction of air pollution.

I encourage you to not use the funding for natural gas, propane or diesel vehicles. Further dependence on fossil fuels means more pollution. Only a transition to electric vehicles and investment in EV infrastructure will put us on the road to a 100% clean transportation sector in North Carolina.

Sincerely,

Judy Smith
2558 Empie Dr.
Leland, NC 28451
jsnorkel23@gmail.com
(910) 228-5056

This message was sent by KnowWho, as a service provider only, on behalf of the individual noted in the sender information.

From: Gloria Shen (gloshen@yahoo.com) Sent You a Personal Message
To: [daq.NC_VWGrants](#)
Subject: [External] Use Volkswagen funds to electrify NC transportation
Date: Tuesday, December 05, 2017 7:08:47 PM

CAUTION: External email. Do not click links or open attachments unless verified. Send all suspicious email as an attachment to report.spam@nc.gov.

Dear Division of Air Quality,

I am writing to urge DEQ to wisely invest the \$92 million in Volkswagen settlement funds in electric vehicles and infrastructure. Taking advantage of these funds to jumpstart the electrification of North Carolina's transportation sector will mean less money sent out of state for petroleum, more in-state jobs, and cleaner air.

Specifically, I recommend that DEQ allocate the maximum allowable amount (15%) of the funds for electric vehicle charging infrastructure and installations. And I encourage DEQ to prioritize electric vehicles and buses for replacement whenever possible with the other 85% of the settlement funds. Doing so will maximize the local economic impact and the reduction of air pollution.

I encourage you to not use the funding for natural gas, propane or diesel vehicles. Further dependence on fossil fuels means more pollution. Only a transition to electric vehicles and investment in EV infrastructure will put us on the road to a 100% clean transportation sector in North Carolina.

Sincerely,

Gloria Shen
40 Rocking Porch Lane
Asheville, NC 28805
gloshen@yahoo.com
(828) 775-6413

This message was sent by KnowWho, as a service provider only, on behalf of the individual noted in the sender information.

From: Barbara Gabriel (barbara2cecilia@gmail.com) Sent You a Personal Message
To: [daq.NC_VWGrants](#)
Subject: [External] Use Volkswagen funds to electrify NC transportation
Date: Tuesday, December 05, 2017 7:06:54 PM

CAUTION: External email. Do not click links or open attachments unless verified. Send all suspicious email as an attachment to report.spam@nc.gov.

Dear Division of Air Quality,

I am writing to urge DEQ to wisely invest the \$92 million in Volkswagen settlement funds in electric vehicles and infrastructure. Taking advantage of these funds to jumpstart the electrification of North Carolina's transportation sector will mean less money sent out of state for petroleum, more in-state jobs, and cleaner air.

Specifically, I recommend that DEQ allocate the maximum allowable amount (15%) of the funds for electric vehicle charging infrastructure and installations. And I encourage DEQ to prioritize electric vehicles and buses for replacement whenever possible with the other 85% of the settlement funds. Doing so will maximize the local economic impact and the reduction of air pollution.

I encourage you to not use the funding for natural gas, propane or diesel vehicles. Further dependence on fossil fuels means more pollution. Only a transition to electric vehicles and investment in EV infrastructure will put us on the road to a 100% clean transportation sector in North Carolina.

Sincerely,

Barbara Gabriel
1300 Blackwood Mtn Rd
Chapel Hill, NC 27516
barbara2cecilia@gmail.com
(919) 270-7735

This message was sent by KnowWho, as a service provider only, on behalf of the individual noted in the sender information.

From: Renee Baker (reneembaker@yahoo.com) Sent You a Personal Message
To: [daq.NC_VWGrants](#)
Subject: [External] Use Volkswagen funds to electrify NC transportation
Date: Tuesday, December 05, 2017 7:04:29 PM

CAUTION: External email. Do not click links or open attachments unless verified. Send all suspicious email as an attachment to report.spam@nc.gov.

Dear Division of Air Quality,

I am writing to urge DEQ to wisely invest the \$92 million in Volkswagen settlement funds in electric vehicles and infrastructure. Taking advantage of these funds to jumpstart the electrification of North Carolina's transportation sector will mean less money sent out of state for petroleum, more in-state jobs, and cleaner air.

Specifically, I recommend that DEQ allocate the maximum allowable amount (15%) of the funds for electric vehicle charging infrastructure and installations. And I encourage DEQ to prioritize electric vehicles and buses for replacement whenever possible with the other 85% of the settlement funds. Doing so will maximize the local economic impact and the reduction of air pollution.

I encourage you to not use the funding for natural gas, propane or diesel vehicles. Further dependence on fossil fuels means more pollution. Only a transition to electric vehicles and investment in EV infrastructure will put us on the road to a 100% clean transportation sector in North Carolina.

Sincerely,

Renee Baker
10836 Wilmore Dr.
Renee, NC 27614
reneembaker@yahoo.com
(919) 656-9931

This message was sent by KnowWho, as a service provider only, on behalf of the individual noted in the sender information.

From: Lori Bright (britespirit1@yahoo.com) Sent You a Personal Message
To: [daq.NC_VWGrants](#)
Subject: [External] Use Volkswagen funds to electrify NC transportation
Date: Tuesday, December 05, 2017 7:02:39 PM

CAUTION: External email. Do not click links or open attachments unless verified. Send all suspicious email as an attachment to report.spam@nc.gov.

Dear Division of Air Quality,

I am writing to urge DEQ to wisely invest the \$92 million in Volkswagen settlement funds in electric vehicles and infrastructure. Taking advantage of these funds to jumpstart the electrification of North Carolina's transportation sector will mean less money sent out of state for petroleum, more in-state jobs, and cleaner air.

Specifically, I recommend that DEQ allocate the maximum allowable amount (15%) of the funds for electric vehicle charging infrastructure and installations. And I encourage DEQ to prioritize electric vehicles and buses for replacement whenever possible with the other 85% of the settlement funds. Doing so will maximize the local economic impact and the reduction of air pollution.

I encourage you to not use the funding for natural gas, propane or diesel vehicles. Further dependence on fossil fuels means more pollution. Only a transition to electric vehicles and investment in EV infrastructure will put us on the road to a 100% clean transportation sector in North Carolina.

Sincerely,

Lori Bright
75 Hickory Tree Rd
Asheville, NC 28805
britespirit1@yahoo.com
(828) 699-7924

This message was sent by KnowWho, as a service provider only, on behalf of the individual noted in the sender information.

From: Anthony Wilks (adwilks57@gmail.com) Sent You a Personal Message
To: [daq.NC_VWGrants](#)
Subject: [External] Use Volkswagen funds to electrify NC transportation
Date: Tuesday, December 05, 2017 7:01:56 PM

CAUTION: External email. Do not click links or open attachments unless verified. Send all suspicious email as an attachment to report.spam@nc.gov.

Dear Division of Air Quality,

I am writing to urge DEQ to wisely invest the \$92 million in Volkswagen settlement funds in electric vehicles and infrastructure. Taking advantage of these funds to jumpstart the electrification of North Carolina's transportation sector will mean less money sent out of state for petroleum, more in-state jobs, and cleaner air.

Specifically, I recommend that DEQ allocate the maximum allowable amount (15%) of the funds for electric vehicle charging infrastructure and installations. And I encourage DEQ to prioritize electric vehicles and buses for replacement whenever possible with the other 85% of the settlement funds. Doing so will maximize the local economic impact and the reduction of air pollution.

I encourage you to not use the funding for natural gas, propane or diesel vehicles. Further dependence on fossil fuels means more pollution. Only a transition to electric vehicles and investment in EV infrastructure will put us on the road to a 100% clean transportation sector in North Carolina.

Sincerely,

Anthony Wilks
1024 Fern Avenue
Charlotte, NC 28208
adwilks57@gmail.com
(704) 200-6986

This message was sent by KnowWho, as a service provider only, on behalf of the individual noted in the sender information.

From: Julie Frey (jrbfrey@gmail.com) Sent You a Personal Message
To: [daq.NC_VWGrants](#)
Subject: [External] Use Volkswagen funds to electrify NC transportation
Date: Tuesday, December 05, 2017 7:01:44 PM

CAUTION: External email. Do not click links or open attachments unless verified. Send all suspicious email as an attachment to report.spam@nc.gov.

Dear Division of Air Quality,

I am writing to urge DEQ to wisely invest the \$92 million in Volkswagen settlement funds in electric vehicles and infrastructure. Taking advantage of these funds to jumpstart the electrification of North Carolina's transportation sector will mean less money sent out of state for petroleum, more in-state jobs, and cleaner air.

Specifically, I recommend that DEQ allocate the maximum allowable amount (15%) of the funds for electric vehicle charging infrastructure and installations. And I encourage DEQ to prioritize electric vehicles and buses for replacement whenever possible with the other 85% of the settlement funds. Doing so will maximize the local economic impact and the reduction of air pollution.

I encourage you to not use the funding for natural gas, propane or diesel vehicles. Further dependence on fossil fuels means more pollution. Only a transition to electric vehicles and investment in EV infrastructure will put us on the road to a 100% clean transportation sector in North Carolina.

Sincerely,

Julie Frey
103 Pine Lake Dr
Monroe, NC 28110
jrbfrey@gmail.com
(704) 776-9364

This message was sent by KnowWho, as a service provider only, on behalf of the individual noted in the sender information.

From: Deborah Milkowski (debmilkocal@twc.com) Sent You a Personal Message
To: [daq.NC_VWGrants](#)
Subject: [External] Use Volkswagen funds to electrify NC transportation
Date: Tuesday, December 05, 2017 7:00:00 PM

CAUTION: External email. Do not click links or open attachments unless verified. Send all suspicious email as an attachment to report.spam@nc.gov.

Dear Division of Air Quality,

I am writing to urge DEQ to wisely invest the \$92 million in Volkswagen settlement funds in electric vehicles and infrastructure. Taking advantage of these funds to jumpstart the electrification of North Carolina's transportation sector will mean less money sent out of state for petroleum, more in-state jobs, and cleaner air.

Specifically, I recommend that DEQ allocate the maximum allowable amount (15%) of the funds for electric vehicle charging infrastructure and installations. And I encourage DEQ to prioritize electric vehicles and buses for replacement whenever possible with the other 85% of the settlement funds. Doing so will maximize the local economic impact and the reduction of air pollution.

I encourage you to not use the funding for natural gas, propane or diesel vehicles. Further dependence on fossil fuels means more pollution. Only a transition to electric vehicles and investment in EV infrastructure will put us on the road to a 100% clean transportation sector in North Carolina.

Sincerely,

Deborah Milkowski
2119 Bay Colony Lane
Wilmington, NC 28405
debmilkocal@twc.com
(252) 571-4330

This message was sent by KnowWho, as a service provider only, on behalf of the individual noted in the sender information.

From: Patricia Lumans (plumans@gmail.com) Sent You a Personal Message
To: [daq.NC_VWGrants](#)
Subject: [External] Use Volkswagen funds to electrify NC transportation
Date: Tuesday, December 05, 2017 6:56:41 PM

CAUTION: External email. Do not click links or open attachments unless verified. Send all suspicious email as an attachment to report.spam@nc.gov.

Dear Division of Air Quality,

I am writing to urge DEQ to wisely invest the \$92 million in Volkswagen settlement funds in electric vehicles and infrastructure. Taking advantage of these funds to jumpstart the electrification of North Carolina's transportation sector will mean less money sent out of state for petroleum, more in-state jobs, and cleaner air.

Specifically, I recommend that DEQ allocate the maximum allowable amount (15%) of the funds for electric vehicle charging infrastructure and installations. And I encourage DEQ to prioritize electric vehicles and buses for replacement whenever possible with the other 85% of the settlement funds. Doing so will maximize the local economic impact and the reduction of air pollution.

I encourage you to not use the funding for natural gas, propane or diesel vehicles. Further dependence on fossil fuels means more pollution. Only a transition to electric vehicles and investment in EV infrastructure will put us on the road to a 100% clean transportation sector in North Carolina.

Sincerely,

Patricia Lumans
107 N. Wake St
Hillsborough, NC 27278
plumans@gmail.com
(803) 979-2100

This message was sent by KnowWho, as a service provider only, on behalf of the individual noted in the sender information.

From: Akila Mosier (soulhunter379@gmail.com) Sent You a Personal Message
To: [daq.NC_VWGrants](#)
Subject: [External] Use Volkswagen funds to electrify NC transportation
Date: Tuesday, December 05, 2017 6:54:03 PM

CAUTION: External email. Do not click links or open attachments unless verified. Send all suspicious email as an attachment to report.spam@nc.gov.

Dear Division of Air Quality,

I am writing to urge DEQ to wisely invest the \$92 million in Volkswagen settlement funds in electric vehicles and infrastructure. Taking advantage of these funds to jumpstart the electrification of North Carolina's transportation sector will mean less money sent out of state for petroleum, more in-state jobs, and cleaner air.

Specifically, I recommend that DEQ allocate the maximum allowable amount (15%) of the funds for electric vehicle charging infrastructure and installations. And I encourage DEQ to prioritize electric vehicles and buses for replacement whenever possible with the other 85% of the settlement funds. Doing so will maximize the local economic impact and the reduction of air pollution.

I encourage you to not use the funding for natural gas, propane or diesel vehicles. Further dependence on fossil fuels means more pollution. Only a transition to electric vehicles and investment in EV infrastructure will put us on the road to a 100% clean transportation sector in North Carolina.

Sincerely,

Akila Mosier
365 Huffmantown Road
Richlands, NC 28574
soulhunter379@gmail.com
(910) 545-7842

This message was sent by KnowWho, as a service provider only, on behalf of the individual noted in the sender information.

From: JAMES HENRY (seamus.p.henry@gmail.com) Sent You a Personal Message
To: [daq.NC_VWGrants](#)
Subject: [External] Use Volkswagen funds to electrify NC transportation
Date: Tuesday, December 05, 2017 6:52:53 PM

CAUTION: External email. Do not click links or open attachments unless verified. Send all suspicious email as an attachment to report.spam@nc.gov.

Dear Division of Air Quality,

I am writing to urge DEQ to wisely invest the \$92 million in Volkswagen settlement funds in electric vehicles and infrastructure. Taking advantage of these funds to jumpstart the electrification of North Carolina's transportation sector will mean less money sent out of state for petroleum, more in-state jobs, and cleaner air.

Specifically, I recommend that DEQ allocate the maximum allowable amount (15%) of the funds for electric vehicle charging infrastructure and installations. And I encourage DEQ to prioritize electric vehicles and buses for replacement whenever possible with the other 85% of the settlement funds. Doing so will maximize the local economic impact and the reduction of air pollution.

I encourage you to not use the funding for natural gas, propane or diesel vehicles. Further dependence on fossil fuels means more pollution. Only a transition to electric vehicles and investment in EV infrastructure will put us on the road to a 100% clean transportation sector in North Carolina.

Sincerely,

JAMES HENRY
631 ANGELICA CIRCLE
CARY, NC 27518
seamus.p.henry@gmail.com
(919) 378-9335

This message was sent by KnowWho, as a service provider only, on behalf of the individual noted in the sender information.

From: Mary Combs (macombs42@yahoo.com) Sent You a Personal Message
To: [daq.NC_VWGrants](#)
Subject: [External] Use Volkswagen funds to electrify NC transportation
Date: Tuesday, December 05, 2017 6:52:18 PM

CAUTION: External email. Do not click links or open attachments unless verified. Send all suspicious email as an attachment to report.spam@nc.gov.

Dear Division of Air Quality,

I am writing to urge DEQ to wisely invest the \$92 million in Volkswagen settlement funds in electric vehicles and infrastructure. Taking advantage of these funds to jumpstart the electrification of North Carolina's transportation sector will mean less money sent out of state for petroleum, more in-state jobs, and cleaner air.

Specifically, I recommend that DEQ allocate the maximum allowable amount (15%) of the funds for electric vehicle charging infrastructure and installations. And I encourage DEQ to prioritize electric vehicles and buses for replacement whenever possible with the other 85% of the settlement funds. Doing so will maximize the local economic impact and the reduction of air pollution.

I encourage you to not use the funding for natural gas, propane or diesel vehicles. Further dependence on fossil fuels means more pollution. Only a transition to electric vehicles and investment in EV infrastructure will put us on the road to a 100% clean transportation sector in North Carolina.

Sincerely,

Mary Combs
1602 Airport Rd
Marion, NC 28752
macombs42@yahoo.com
(828) 559-0110

This message was sent by KnowWho, as a service provider only, on behalf of the individual noted in the sender information.

From: kat nakayama (tkmn@aol.com) Sent You a Personal Message
To: [daq.NC_VWGrants](#)
Subject: [External] Use Volkswagen funds to electrify NC transportation
Date: Tuesday, December 05, 2017 6:50:40 PM

CAUTION: External email. Do not click links or open attachments unless verified. Send all suspicious email as an attachment to report.spam@nc.gov.

Dear Division of Air Quality,

I am writing to urge DEQ to wisely invest the \$92 million in Volkswagen settlement funds in electric vehicles and infrastructure. Taking advantage of these funds to jumpstart the electrification of North Carolina's transportation sector will mean less money sent out of state for petroleum, more in-state jobs, and cleaner air.

Specifically, I recommend that DEQ allocate the maximum allowable amount (15%) of the funds for electric vehicle charging infrastructure and installations. And I encourage DEQ to prioritize electric vehicles and buses for replacement whenever possible with the other 85% of the settlement funds. Doing so will maximize the local economic impact and the reduction of air pollution.

I encourage you to not use the funding for natural gas, propane or diesel vehicles. Further dependence on fossil fuels means more pollution. Only a transition to electric vehicles and investment in EV infrastructure will put us on the road to a 100% clean transportation sector in North Carolina.

Sincerely,

kat nakayama
2612 quaker landing rd
greensboro, NC 27455
tkmn@aol.com
(336) 540-1610

This message was sent by KnowWho, as a service provider only, on behalf of the individual noted in the sender information.

From: Matthew Rubino (matt_rubino@ncsu.edu) Sent You a Personal Message
To: [daq.NC_VWGrants](#)
Subject: [External] Use Volkswagen funds to electrify NC transportation
Date: Tuesday, December 05, 2017 6:50:39 PM

CAUTION: External email. Do not click links or open attachments unless verified. Send all suspicious email as an attachment to report.spam@nc.gov.

Dear Division of Air Quality,

I am writing to urge DEQ to wisely invest the \$92 million in Volkswagen settlement funds in electric vehicles and infrastructure. Taking advantage of these funds to jumpstart the electrification of North Carolina's transportation sector will mean less money sent out of state for petroleum, more in-state jobs, and cleaner air.

Specifically, I recommend that DEQ allocate the maximum allowable amount (15%) of the funds for electric vehicle charging infrastructure and installations. And I encourage DEQ to prioritize electric vehicles and buses for replacement whenever possible with the other 85% of the settlement funds. Doing so will maximize the local economic impact and the reduction of air pollution.

I encourage you to not use the funding for natural gas, propane or diesel vehicles. Further dependence on fossil fuels means more pollution. Only a transition to electric vehicles and investment in EV infrastructure will put us on the road to a 100% clean transportation sector in North Carolina.

Sincerely,

Matthew Rubino
218 D. Clark Labs NCSU Dept. of Applied Ecology
Raleigh, NC 27695
matt_rubino@ncsu.edu
(919) 513-7280

This message was sent by KnowWho, as a service provider only, on behalf of the individual noted in the sender information.

From: David Lussier (papaskwidd@gmail.com) Sent You a Personal Message
To: [daq.NC_VWGrants](#)
Subject: [External] Use Volkswagen funds to electrify NC transportation
Date: Tuesday, December 05, 2017 6:50:38 PM

CAUTION: External email. Do not click links or open attachments unless verified. Send all suspicious email as an attachment to report.spam@nc.gov.

Dear Division of Air Quality,

I am writing to urge DEQ to wisely invest the \$92 million in Volkswagen settlement funds in electric vehicles and infrastructure. Taking advantage of these funds to jumpstart the electrification of North Carolina's transportation sector will mean less money sent out of state for petroleum, more in-state jobs, and cleaner air.

Specifically, I recommend that DEQ allocate the maximum allowable amount (15%) of the funds for electric vehicle charging infrastructure and installations. And I encourage DEQ to prioritize electric vehicles and buses for replacement whenever possible with the other 85% of the settlement funds. Doing so will maximize the local economic impact and the reduction of air pollution.

I encourage you to not use the funding for natural gas, propane or diesel vehicles. Further dependence on fossil fuels means more pollution. Only a transition to electric vehicles and investment in EV infrastructure will put us on the road to a 100% clean transportation sector in North Carolina.

Sincerely,

David Lussier
707 Churchill Downs Drive
Aberdeen, NC 28315
papaskwidd@gmail.com
(336) 803-9326

This message was sent by KnowWho, as a service provider only, on behalf of the individual noted in the sender information.

From: Cathy Holt (cathyholt@gmail.com) Sent You a Personal Message
To: [daq.NC_VWGrants](#)
Subject: [External] Use Volkswagen funds to electrify NC transportation
Date: Tuesday, December 05, 2017 6:45:11 PM

CAUTION: External email. Do not click links or open attachments unless verified. Send all suspicious email as an attachment to report.spam@nc.gov.

Dear Division of Air Quality,

I am writing to urge DEQ to wisely invest the \$92 million in Volkswagen settlement funds in electric vehicles and infrastructure. Taking advantage of these funds to jumpstart the electrification of North Carolina's transportation sector will mean less money sent out of state for petroleum, more in-state jobs, and cleaner air.

Specifically, I recommend that DEQ allocate the maximum allowable amount (15%) of the funds for electric vehicle charging infrastructure and installations. And I encourage DEQ to prioritize electric vehicles and buses for replacement whenever possible with the other 85% of the settlement funds. Doing so will maximize the local economic impact and the reduction of air pollution.

I encourage you to not use the funding for natural gas, propane or diesel vehicles. Further dependence on fossil fuels means more pollution. Only a transition to electric vehicles and investment in EV infrastructure will put us on the road to a 100% clean transportation sector in North Carolina.

Sincerely,

Cathy Holt
386 Kenilworth Rd.
Cathy, NC 28805
cathyholt@gmail.com
(828) 545-9681

This message was sent by KnowWho, as a service provider only, on behalf of the individual noted in the sender information.

From: Brian Reed (btreed91@gmail.com) Sent You a Personal Message
To: [daq.NC_VWGrants](#)
Subject: [External] Use Volkswagen funds to electrify NC transportation
Date: Tuesday, December 05, 2017 6:41:25 PM

CAUTION: External email. Do not click links or open attachments unless verified. Send all suspicious email as an attachment to report.spam@nc.gov.

Dear Division of Air Quality,

I am writing to urge DEQ to wisely invest the \$92 million in Volkswagen settlement funds in electric vehicles and infrastructure. Taking advantage of these funds to jumpstart the electrification of North Carolina's transportation sector will mean less money sent out of state for petroleum, more in-state jobs, and cleaner air.

Specifically, I recommend that DEQ allocate the maximum allowable amount (15%) of the funds for electric vehicle charging infrastructure and installations. And I encourage DEQ to prioritize electric vehicles and buses for replacement whenever possible with the other 85% of the settlement funds. Doing so will maximize the local economic impact and the reduction of air pollution.

I encourage you to not use the funding for natural gas, propane or diesel vehicles. Further dependence on fossil fuels means more pollution. Only a transition to electric vehicles and investment in EV infrastructure will put us on the road to a 100% clean transportation sector in North Carolina.

Sincerely,

Brian Reed
2025 Lakebay Rd
Vass, NC 28394
btreed91@gmail.com
(404) 661-2241

This message was sent by KnowWho, as a service provider only, on behalf of the individual noted in the sender information.

From: Laura Smith (laurapancoast78@gmail.com) Sent You a Personal Message
To: [daq.NC_VWGrants](#)
Subject: [External] Use Volkswagen funds to electrify NC transportation
Date: Tuesday, December 05, 2017 6:41:12 PM

CAUTION: External email. Do not click links or open attachments unless verified. Send all suspicious email as an attachment to report.spam@nc.gov.

Dear Division of Air Quality,

I am writing to urge DEQ to wisely invest the \$92 million in Volkswagen settlement funds in electric vehicles and infrastructure. Taking advantage of these funds to jumpstart the electrification of North Carolina's transportation sector will mean less money sent out of state for petroleum, more in-state jobs, and cleaner air.

Specifically, I recommend that DEQ allocate the maximum allowable amount (15%) of the funds for electric vehicle charging infrastructure and installations. And I encourage DEQ to prioritize electric vehicles and buses for replacement whenever possible with the other 85% of the settlement funds. Doing so will maximize the local economic impact and the reduction of air pollution.

I encourage you to not use the funding for natural gas, propane or diesel vehicles. Further dependence on fossil fuels means more pollution. Only a transition to electric vehicles and investment in EV infrastructure will put us on the road to a 100% clean transportation sector in North Carolina.

Sincerely,

Laura Smith
2196 Woodview Drive
Raleigh, NC 27604
laurapancoast78@gmail.com
(919) 821-0396

This message was sent by KnowWho, as a service provider only, on behalf of the individual noted in the sender information.

From: danna mcintock (danna.mcintock@gmail.com) Sent You a Personal Message
To: [daq.NC_VWGrants](#)
Subject: [External] Use Volkswagen funds to electrify NC transportation
Date: Tuesday, December 05, 2017 6:35:56 PM

CAUTION: External email. Do not click links or open attachments unless verified. Send all suspicious email as an attachment to report.spam@nc.gov.

Dear Division of Air Quality,

I am writing to urge DEQ to wisely invest the \$92 million in Volkswagen settlement funds in electric vehicles and infrastructure. Taking advantage of these funds to jumpstart the electrification of North Carolina's transportation sector will mean less money sent out of state for petroleum, more in-state jobs, and cleaner air.

Specifically, I recommend that DEQ allocate the maximum allowable amount (15%) of the funds for electric vehicle charging infrastructure and installations. And I encourage DEQ to prioritize electric vehicles and buses for replacement whenever possible with the other 85% of the settlement funds. Doing so will maximize the local economic impact and the reduction of air pollution.

I encourage you to not use the funding for natural gas, propane or diesel vehicles. Further dependence on fossil fuels means more pollution. Only a transition to electric vehicles and investment in EV infrastructure will put us on the road to a 100% clean transportation sector in North Carolina.

Sincerely,

danna mcintock
920 tumbling fork rd
waynesville, NC 28785
danna.mcintock@gmail.com
(904) 388-3188

This message was sent by KnowWho, as a service provider only, on behalf of the individual noted in the sender information.

From: Georgia Sizemore (gah2obaby@gmail.com) Sent You a Personal Message
To: [daq.NC_VWGrants](#)
Subject: [External] Use Volkswagen funds to electrify NC transportation
Date: Tuesday, December 05, 2017 6:35:55 PM

CAUTION: External email. Do not click links or open attachments unless verified. Send all suspicious email as an attachment to report.spam@nc.gov.

Dear Division of Air Quality,

I am writing to urge DEQ to wisely invest the \$92 million in Volkswagen settlement funds in electric vehicles and infrastructure. Taking advantage of these funds to jumpstart the electrification of North Carolina's transportation sector will mean less money sent out of state for petroleum, more in-state jobs, and cleaner air.

Specifically, I recommend that DEQ allocate the maximum allowable amount (15%) of the funds for electric vehicle charging infrastructure and installations. And I encourage DEQ to prioritize electric vehicles and buses for replacement whenever possible with the other 85% of the settlement funds. Doing so will maximize the local economic impact and the reduction of air pollution.

I encourage you to not use the funding for natural gas, propane or diesel vehicles. Further dependence on fossil fuels means more pollution. Only a transition to electric vehicles and investment in EV infrastructure will put us on the road to a 100% clean transportation sector in North Carolina.

Sincerely,

Georgia Sizemore
PO Box 304
Rutherfordton, NC 28139
gah2obaby@gmail.com
(828) 216-2983

This message was sent by KnowWho, as a service provider only, on behalf of the individual noted in the sender information.

From: Joan Learner (jmlearner@yahoo.com) Sent You a Personal Message
To: [daq.NC_VWGrants](#)
Subject: [External] Use Volkswagen funds to electrify NC transportation
Date: Tuesday, December 05, 2017 6:29:14 PM

CAUTION: External email. Do not click links or open attachments unless verified. Send all suspicious email as an attachment to report.spam@nc.gov.

Dear Division of Air Quality,

I am writing to urge DEQ to wisely invest the \$92 million in Volkswagen settlement funds in electric vehicles and infrastructure. Taking advantage of these funds to jumpstart the electrification of North Carolina's transportation sector will mean less money sent out of state for petroleum, more in-state jobs, and cleaner air.

Specifically, I recommend that DEQ allocate the maximum allowable amount (15%) of the funds for electric vehicle charging infrastructure and installations. And I encourage DEQ to prioritize electric vehicles and buses for replacement whenever possible with the other 85% of the settlement funds. Doing so will maximize the local economic impact and the reduction of air pollution.

I encourage you to not use the funding for natural gas, propane or diesel vehicles. Further dependence on fossil fuels means more pollution. Only a transition to electric vehicles and investment in EV infrastructure will put us on the road to a 100% clean transportation sector in North Carolina.

Sincerely,

Joan Learner
10820 Galand Court
Raleigh, NC 27614
jmlearner@yahoo.com
(919) 870-0733

This message was sent by KnowWho, as a service provider only, on behalf of the individual noted in the sender information.

From: Stephen Wise (csaw@jhu.edu) Sent You a Personal Message
To: [daq.NC_VWGrants](#)
Subject: [External] Use Volkswagen funds to electrify NC transportation
Date: Tuesday, December 05, 2017 6:28:31 PM

CAUTION: External email. Do not click links or open attachments unless verified. Send all suspicious email as an attachment to report.spam@nc.gov.

Dear Division of Air Quality,

I am writing to urge DEQ to wisely invest the \$92 million in Volkswagen settlement funds in electric vehicles and infrastructure. Taking advantage of these funds to jumpstart the electrification of North Carolina's transportation sector will mean less money sent out of state for petroleum, more in-state jobs, and cleaner air.

Specifically, I recommend that DEQ allocate the maximum allowable amount (15%) of the funds for electric vehicle charging infrastructure and installations. And I encourage DEQ to prioritize electric vehicles and buses for replacement whenever possible with the other 85% of the settlement funds. Doing so will maximize the local economic impact and the reduction of air pollution.

I encourage you to not use the funding for natural gas, propane or diesel vehicles. Further dependence on fossil fuels means more pollution. Only a transition to electric vehicles and investment in EV infrastructure will put us on the road to a 100% clean transportation sector in North Carolina.

Sincerely,

Stephen Wise
1337 E Morehead St Apt 204
Charlotte, NC 28204
csaw@jhu.edu
(704) 332-3976

This message was sent by KnowWho, as a service provider only, on behalf of the individual noted in the sender information.

From: Christopher Browder (kcfoxie@gmail.com) Sent You a Personal Message
To: [daq.NC_VWGrants](#)
Subject: [External] Use Volkswagen funds to electrify NC transportation
Date: Tuesday, December 05, 2017 6:27:13 PM

CAUTION: External email. Do not click links or open attachments unless verified. Send all suspicious email as an attachment to report.spam@nc.gov.

Dear Division of Air Quality,

I am writing to urge DEQ to wisely invest the \$92 million in Volkswagen settlement funds in electric vehicles and infrastructure. Taking advantage of these funds to jumpstart the electrification of North Carolina's transportation sector will mean less money sent out of state for petroleum, more in-state jobs, and cleaner air.

Specifically, I recommend that DEQ allocate the maximum allowable amount (15%) of the funds for electric vehicle charging infrastructure and installations. And I encourage DEQ to prioritize electric vehicles and buses for replacement whenever possible with the other 85% of the settlement funds. Doing so will maximize the local economic impact and the reduction of air pollution.

I encourage you to not use the funding for natural gas, propane or diesel vehicles. Further dependence on fossil fuels means more pollution. Only a transition to electric vehicles and investment in EV infrastructure will put us on the road to a 100% clean transportation sector in North Carolina.

Sincerely,

Christopher Browder
3512 Carolyn Dr
Raleigh, NC 27604
kcfoxie@gmail.com
(919) 909-4517

This message was sent by KnowWho, as a service provider only, on behalf of the individual noted in the sender information.

From: Roberta Stacey (rstacey13@gmail.com) Sent You a Personal Message
To: [daq.NC_VWGrants](#)
Subject: [External] Use Volkswagen funds to electrify NC transportation
Date: Tuesday, December 05, 2017 6:27:12 PM

CAUTION: External email. Do not click links or open attachments unless verified. Send all suspicious email as an attachment to report.spam@nc.gov.

Dear Division of Air Quality,

I am writing to urge DEQ to wisely invest the \$92 million in Volkswagen settlement funds in electric vehicles and infrastructure. Taking advantage of these funds to jumpstart the electrification of North Carolina's transportation sector will mean less money sent out of state for petroleum, more in-state jobs, and cleaner air.

Specifically, I recommend that DEQ allocate the maximum allowable amount (15%) of the funds for electric vehicle charging infrastructure and installations. And I encourage DEQ to prioritize electric vehicles and buses for replacement whenever possible with the other 85% of the settlement funds. Doing so will maximize the local economic impact and the reduction of air pollution.

I encourage you to not use the funding for natural gas, propane or diesel vehicles. Further dependence on fossil fuels means more pollution. Only a transition to electric vehicles and investment in EV infrastructure will put us on the road to a 100% clean transportation sector in North Carolina.

Sincerely,

Roberta Stacey
600 South Churton St.
Hillsborough, NC 27278
rstacey13@gmail.com
(919) 245-8669

This message was sent by KnowWho, as a service provider only, on behalf of the individual noted in the sender information.

From: Kathryn Armstrong (armstrong.kathyg@yahoo.com) Sent You a Personal Message
To: [daq.NC_VWGrants](#)
Subject: [External] Use Volkswagen funds to electrify NC transportation
Date: Tuesday, December 05, 2017 6:27:12 PM

CAUTION: External email. Do not click links or open attachments unless verified. Send all suspicious email as an attachment to report.spam@nc.gov.

Dear Division of Air Quality,

I am writing to urge DEQ to wisely invest the \$92 million in Volkswagen settlement funds in electric vehicles and infrastructure. Taking advantage of these funds to jumpstart the electrification of North Carolina's transportation sector will mean less money sent out of state for petroleum, more in-state jobs, and cleaner air.

Specifically, I recommend that DEQ allocate the maximum allowable amount (15%) of the funds for electric vehicle charging infrastructure and installations. And I encourage DEQ to prioritize electric vehicles and buses for replacement whenever possible with the other 85% of the settlement funds. Doing so will maximize the local economic impact and the reduction of air pollution.

I encourage you to not use the funding for natural gas, propane or diesel vehicles. Further dependence on fossil fuels means more pollution. Only a transition to electric vehicles and investment in EV infrastructure will put us on the road to a 100% clean transportation sector in North Carolina.

Sincerely,

Kathryn Armstrong
1008 Ponape Ct
Indian Trail, NC 28079
armstrong.kathyg@yahoo.com
(704) 893-0111

This message was sent by KnowWho, as a service provider only, on behalf of the individual noted in the sender information.

From: Ruby Sturcey (rsturcey@gmail.com) Sent You a Personal Message
To: [daq.NC_VWGrants](#)
Subject: [External] Use Volkswagen funds to electrify NC transportation
Date: Tuesday, December 05, 2017 6:26:42 PM

CAUTION: External email. Do not click links or open attachments unless verified. Send all suspicious email as an attachment to report.spam@nc.gov.

Dear Division of Air Quality,

I am writing to urge DEQ to wisely invest the \$92 million in Volkswagen settlement funds in electric vehicles and infrastructure. Taking advantage of these funds to jumpstart the electrification of North Carolina's transportation sector will mean less money sent out of state for petroleum, more in-state jobs, and cleaner air.

Specifically, I recommend that DEQ allocate the maximum allowable amount (15%) of the funds for electric vehicle charging infrastructure and installations. And I encourage DEQ to prioritize electric vehicles and buses for replacement whenever possible with the other 85% of the settlement funds. Doing so will maximize the local economic impact and the reduction of air pollution.

I encourage you to not use the funding for natural gas, propane or diesel vehicles. Further dependence on fossil fuels means more pollution. Only a transition to electric vehicles and investment in EV infrastructure will put us on the road to a 100% clean transportation sector in North Carolina.

Sincerely,

Ruby Sturcey
6360 LowderRoad
Salisbury, NC 28147
rsturcey@gmail.com
(910) 709-9148

This message was sent by KnowWho, as a service provider only, on behalf of the individual noted in the sender information.

From: Cheryl Haislar (haislacr@miamioh.edu) Sent You a Personal Message
To: [daq.NC_VWGrants](#)
Subject: [External] Use Volkswagen funds to electrify NC transportation
Date: Tuesday, December 05, 2017 6:26:31 PM

CAUTION: External email. Do not click links or open attachments unless verified. Send all suspicious email as an attachment to report.spam@nc.gov.

Dear Division of Air Quality,

I am writing to urge DEQ to wisely invest the \$92 million in Volkswagen settlement funds in electric vehicles and infrastructure. Taking advantage of these funds to jumpstart the electrification of North Carolina's transportation sector will mean less money sent out of state for petroleum, more in-state jobs, and cleaner air.

Specifically, I recommend that DEQ allocate the maximum allowable amount (15%) of the funds for electric vehicle charging infrastructure and installations. And I encourage DEQ to prioritize electric vehicles and buses for replacement whenever possible with the other 85% of the settlement funds. Doing so will maximize the local economic impact and the reduction of air pollution.

I encourage you to not use the funding for natural gas, propane or diesel vehicles. Further dependence on fossil fuels means more pollution. Only a transition to electric vehicles and investment in EV infrastructure will put us on the road to a 100% clean transportation sector in North Carolina.

Sincerely,

Cheryl Haislar
1169 Soquili
Brevard, NC 28712
haislacr@miamioh.edu
(828) 883-3664

This message was sent by KnowWho, as a service provider only, on behalf of the individual noted in the sender information.

From: Jennifer Headley (jennifer_headley@yahoo.com) Sent You a Personal Message
To: [daq.NC_VWGrants](#)
Subject: [External] Use Volkswagen funds to electrify NC transportation
Date: Tuesday, December 05, 2017 6:24:59 PM

CAUTION: External email. Do not click links or open attachments unless verified. Send all suspicious email as an attachment to report.spam@nc.gov.

Dear Division of Air Quality,

I am writing to urge DEQ to wisely invest the \$92 million in Volkswagen settlement funds in electric vehicles and infrastructure. Taking advantage of these funds to jumpstart the electrification of North Carolina's transportation sector will mean less money sent out of state for petroleum, more in-state jobs, and cleaner air.

Specifically, I recommend that DEQ allocate the maximum allowable amount (15%) of the funds for electric vehicle charging infrastructure and installations. And I encourage DEQ to prioritize electric vehicles and buses for replacement whenever possible with the other 85% of the settlement funds. Doing so will maximize the local economic impact and the reduction of air pollution.

I encourage you to not use the funding for natural gas, propane or diesel vehicles. Further dependence on fossil fuels means more pollution. Only a transition to electric vehicles and investment in EV infrastructure will put us on the road to a 100% clean transportation sector in North Carolina.

Sincerely,

Jennifer Headley
124 W Lynch St
Durham, NC 27701
jennifer_headley@yahoo.com
(919) 370-1411

This message was sent by KnowWho, as a service provider only, on behalf of the individual noted in the sender information.

From: Randall Faircloth (n10dorcf@aol.com) Sent You a Personal Message
To: [daq.NC_VWGrants](#)
Subject: [External] Use Volkswagen funds to electrify NC transportation
Date: Tuesday, December 05, 2017 6:23:56 PM

CAUTION: External email. Do not click links or open attachments unless verified. Send all suspicious email as an attachment to report.spam@nc.gov.

Dear Division of Air Quality,

I am writing to urge DEQ to wisely invest the \$92 million in Volkswagen settlement funds in electric vehicles and infrastructure. Taking advantage of these funds to jumpstart the electrification of North Carolina's transportation sector will mean less money sent out of state for petroleum, more in-state jobs, and cleaner air.

Specifically, I recommend that DEQ allocate the maximum allowable amount (15%) of the funds for electric vehicle charging infrastructure and installations. And I encourage DEQ to prioritize electric vehicles and buses for replacement whenever possible with the other 85% of the settlement funds. Doing so will maximize the local economic impact and the reduction of air pollution.

I encourage you to not use the funding for natural gas, propane or diesel vehicles. Further dependence on fossil fuels means more pollution. Only a transition to electric vehicles and investment in EV infrastructure will put us on the road to a 100% clean transportation sector in North Carolina.

Sincerely,

Randall Faircloth
4918 Woods Edge Road
Wilmington, NC 28409
n10dorcf@aol.com
(910) 452-0653

This message was sent by KnowWho, as a service provider only, on behalf of the individual noted in the sender information.

From: Mary Beth Thomas (thomasmb1980@gmail.com) Sent You a Personal Message
To: [daq.NC_VWGrants](#)
Subject: [External] Use Volkswagen funds to electrify NC transportation
Date: Tuesday, December 05, 2017 6:20:46 PM

CAUTION: External email. Do not click links or open attachments unless verified. Send all suspicious email as an attachment to report.spam@nc.gov.

Dear Division of Air Quality,

I am writing to urge DEQ to wisely invest the \$92 million in Volkswagen settlement funds in electric vehicles and infrastructure. Taking advantage of these funds to jumpstart the electrification of North Carolina's transportation sector will mean less money sent out of state for petroleum, more in-state jobs, and cleaner air.

Specifically, I recommend that DEQ allocate the maximum allowable amount (15%) of the funds for electric vehicle charging infrastructure and installations. And I encourage DEQ to prioritize electric vehicles and buses for replacement whenever possible with the other 85% of the settlement funds. Doing so will maximize the local economic impact and the reduction of air pollution.

I encourage you to not use the funding for natural gas, propane or diesel vehicles. Further dependence on fossil fuels means more pollution. Only a transition to electric vehicles and investment in EV infrastructure will put us on the road to a 100% clean transportation sector in North Carolina.

Sincerely,

Mary Beth Thomas
4633 Spicewood Drive
Charlotte, NC 28227
thomasmb1980@gmail.com
(704) 545-0509

This message was sent by KnowWho, as a service provider only, on behalf of the individual noted in the sender information.

From: Kurt Nichols (kurt411@gmail.com) Sent You a Personal Message
To: [daq.NC_VWGrants](#)
Subject: [External] Use Volkswagen funds to electrify NC transportation
Date: Tuesday, December 05, 2017 6:17:34 PM

CAUTION: External email. Do not click links or open attachments unless verified. Send all suspicious email as an attachment to report.spam@nc.gov.

Dear Division of Air Quality,

I am writing to urge DEQ to wisely invest the \$92 million in Volkswagen settlement funds in electric vehicles and infrastructure. Taking advantage of these funds to jumpstart the electrification of North Carolina's transportation sector will mean less money sent out of state for petroleum, more in-state jobs, and cleaner air.

Specifically, I recommend that DEQ allocate the maximum allowable amount (15%) of the funds for electric vehicle charging infrastructure and installations. And I encourage DEQ to prioritize electric vehicles and buses for replacement whenever possible with the other 85% of the settlement funds. Doing so will maximize the local economic impact and the reduction of air pollution.

I encourage you to not use the funding for natural gas, propane or diesel vehicles. Further dependence on fossil fuels means more pollution. Only a transition to electric vehicles and investment in EV infrastructure will put us on the road to a 100% clean transportation sector in North Carolina.

Sincerely,

Kurt Nichols
12059 copper mountain Blvd
Charlotte, NC 28277
kurt411@gmail.com
(239) 248-6864

This message was sent by KnowWho, as a service provider only, on behalf of the individual noted in the sender information.

From: Penelope Voss (pjdancer@gmail.com) Sent You a Personal Message
To: [daq.NC_VWGrants](#)
Subject: [External] Use Volkswagen funds to electrify NC transportation
Date: Tuesday, December 05, 2017 6:16:26 PM

CAUTION: External email. Do not click links or open attachments unless verified. Send all suspicious email as an attachment to report.spam@nc.gov.

Dear Division of Air Quality,

I am writing to urge DEQ to wisely invest the \$92 million in Volkswagen settlement funds in electric vehicles and infrastructure. Taking advantage of these funds to jumpstart the electrification of North Carolina's transportation sector will mean less money sent out of state for petroleum, more in-state jobs, and cleaner air.

Specifically, I recommend that DEQ allocate the maximum allowable amount (15%) of the funds for electric vehicle charging infrastructure and installations. And I encourage DEQ to prioritize electric vehicles and buses for replacement whenever possible with the other 85% of the settlement funds. Doing so will maximize the local economic impact and the reduction of air pollution.

I encourage you to not use the funding for natural gas, propane or diesel vehicles. Further dependence on fossil fuels means more pollution. Only a transition to electric vehicles and investment in EV infrastructure will put us on the road to a 100% clean transportation sector in North Carolina.

Sincerely,

Penelope Voss
13228 Brown Grier Rd.
Charlotte, NC 28273
pjdancer@gmail.com
(843) 939-7644

This message was sent by KnowWho, as a service provider only, on behalf of the individual noted in the sender information.

From: Virginia Matthews (gini.matt@frontier.com) Sent You a Personal Message
To: [daq.NC_VWGrants](#)
Subject: [External] Use Volkswagen funds to electrify NC transportation
Date: Tuesday, December 05, 2017 6:13:29 PM

CAUTION: External email. Do not click links or open attachments unless verified. Send all suspicious email as an attachment to report.spam@nc.gov.

Dear Division of Air Quality,

I am writing to urge DEQ to wisely invest the \$92 million in Volkswagen settlement funds in electric vehicles and infrastructure. Taking advantage of these funds to jumpstart the electrification of North Carolina's transportation sector will mean less money sent out of state for petroleum, more in-state jobs, and cleaner air.

Specifically, I recommend that DEQ allocate the maximum allowable amount (15%) of the funds for electric vehicle charging infrastructure and installations. And I encourage DEQ to prioritize electric vehicles and buses for replacement whenever possible with the other 85% of the settlement funds. Doing so will maximize the local economic impact and the reduction of air pollution.

I encourage you to not use the funding for natural gas, propane or diesel vehicles. Further dependence on fossil fuels means more pollution. Only a transition to electric vehicles and investment in EV infrastructure will put us on the road to a 100% clean transportation sector in North Carolina.

Sincerely,

Virginia Matthews
11 Cobblestone Court
Durham, NC 27713
gini.matt@frontier.com
(919) 417-4402

This message was sent by KnowWho, as a service provider only, on behalf of the individual noted in the sender information.

From: Janet Black (ecochristian@yahoo.com) Sent You a Personal Message
To: [daq.NC_VWGrants](#)
Subject: [External] Use Volkswagen funds to electrify NC transportation
Date: Tuesday, December 05, 2017 6:12:25 PM

CAUTION: External email. Do not click links or open attachments unless verified. Send all suspicious email as an attachment to report.spam@nc.gov.

Dear Division of Air Quality,

I am writing to urge DEQ to wisely invest the \$92 million in Volkswagen settlement funds in electric vehicles and infrastructure. Taking advantage of these funds to jumpstart the electrification of North Carolina's transportation sector will mean less money sent out of state for petroleum, more in-state jobs, and cleaner air.

Specifically, I recommend that DEQ allocate the maximum allowable amount (15%) of the funds for electric vehicle charging infrastructure and installations. And I encourage DEQ to prioritize electric vehicles and buses for replacement whenever possible with the other 85% of the settlement funds. Doing so will maximize the local economic impact and the reduction of air pollution.

I encourage you to not use the funding for natural gas, propane or diesel vehicles. Further dependence on fossil fuels means more pollution. Only a transition to electric vehicles and investment in EV infrastructure will put us on the road to a 100% clean transportation sector in North Carolina.

Sincerely,

Janet Black
12 Warren Creek Rd
Candler, NC 28715
ecochristian@yahoo.com
(828) 633-0327

This message was sent by KnowWho, as a service provider only, on behalf of the individual noted in the sender information.

From: Kermit R. Davis (krd226@bellsouth.net) Sent You a Personal Message
To: [daq.NC_VWGrants](#)
Subject: [External] Use Volkswagen funds to electrify NC transportation
Date: Tuesday, December 05, 2017 6:09:00 PM

CAUTION: External email. Do not click links or open attachments unless verified. Send all suspicious email as an attachment to report.spam@nc.gov.

Dear Division of Air Quality,

I am writing to urge DEQ to wisely invest the \$92 million in Volkswagen settlement funds in electric vehicles and infrastructure. Taking advantage of these funds to jumpstart the electrification of North Carolina's transportation sector will mean less money sent out of state for petroleum, more in-state jobs, and cleaner air.

Specifically, I recommend that DEQ allocate the maximum allowable amount (15%) of the funds for electric vehicle charging infrastructure and installations. And I encourage DEQ to prioritize electric vehicles and buses for replacement whenever possible with the other 85% of the settlement funds. Doing so will maximize the local economic impact and the reduction of air pollution.

I encourage you to not use the funding for natural gas, propane or diesel vehicles. Further dependence on fossil fuels means more pollution. Only a transition to electric vehicles and investment in EV infrastructure will put us on the road to a 100% clean transportation sector in North Carolina.

Sincerely,

Kermit R. Davis
386 Licklog Ridge
Hayesville, NC 28904
krd226@bellsouth.net
(828) 389-4276

This message was sent by KnowWho, as a service provider only, on behalf of the individual noted in the sender information.

From: Dorothy Wahlers (dorothywahlers@yahoo.com) Sent You a Personal Message
To: [daq.NC_VWGrants](#)
Subject: [External] Use Volkswagen funds to electrify NC transportation
Date: Tuesday, December 05, 2017 6:07:35 PM

CAUTION: External email. Do not click links or open attachments unless verified. Send all suspicious email as an attachment to report.spam@nc.gov.

Dear Division of Air Quality,

I am writing to urge DEQ to wisely invest the \$92 million in Volkswagen settlement funds in electric vehicles and infrastructure. Taking advantage of these funds to jumpstart the electrification of North Carolina's transportation sector will mean less money sent out of state for petroleum, more in-state jobs, and cleaner air.

Specifically, I recommend that DEQ allocate the maximum allowable amount (15%) of the funds for electric vehicle charging infrastructure and installations. And I encourage DEQ to prioritize electric vehicles and buses for replacement whenever possible with the other 85% of the settlement funds. Doing so will maximize the local economic impact and the reduction of air pollution.

I encourage you to not use the funding for natural gas, propane or diesel vehicles. Further dependence on fossil fuels means more pollution. Only a transition to electric vehicles and investment in EV infrastructure will put us on the road to a 100% clean transportation sector in North Carolina.

Sincerely,

Dorothy Wahlers
109 REDDES RIVER CT
Hertford, NC 27944
dorothywahlers@yahoo.com
(732) 286-3848

This message was sent by KnowWho, as a service provider only, on behalf of the individual noted in the sender information.

From: Richard McHenry (richardmchenry@mac.com) Sent You a Personal Message
To: [daq.NC_VWGrants](#)
Subject: [External] Use Volkswagen funds to electrify NC transportation
Date: Tuesday, December 05, 2017 6:04:24 PM

CAUTION: External email. Do not click links or open attachments unless verified. Send all suspicious email as an attachment to report.spam@nc.gov.

Dear Division of Air Quality,

I am writing to urge DEQ to wisely invest the \$92 million in Volkswagen settlement funds in electric vehicles and infrastructure. Taking advantage of these funds to jumpstart the electrification of North Carolina's transportation sector will mean less money sent out of state for petroleum, more in-state jobs, and cleaner air.

Specifically, I recommend that DEQ allocate the maximum allowable amount (15%) of the funds for electric vehicle charging infrastructure and installations. And I encourage DEQ to prioritize electric vehicles and buses for replacement whenever possible with the other 85% of the settlement funds. Doing so will maximize the local economic impact and the reduction of air pollution.

I encourage you to not use the funding for natural gas, propane or diesel vehicles. Further dependence on fossil fuels means more pollution. Only a transition to electric vehicles and investment in EV infrastructure will put us on the road to a 100% clean transportation sector in North Carolina.

Sincerely,

Richard McHenry
499 Forest Lake Est
Moncure, NC 27559
richardmchenry@mac.com
(919) 244-4671

This message was sent by KnowWho, as a service provider only, on behalf of the individual noted in the sender information.

From: Jenafur Maher-Bernard (jmaherbernard@gmail.com) Sent You a Personal Message
To: [daq.NC_VWGrants](#)
Subject: [External] Use Volkswagen funds to electrify NC transportation
Date: Tuesday, December 05, 2017 6:03:54 PM

CAUTION: External email. Do not click links or open attachments unless verified. Send all suspicious email as an attachment to report.spam@nc.gov.

Dear Division of Air Quality,

I am writing to urge DEQ to wisely invest the \$92 million in Volkswagen settlement funds in electric vehicles and infrastructure. Taking advantage of these funds to jumpstart the electrification of North Carolina's transportation sector will mean less money sent out of state for petroleum, more in-state jobs, and cleaner air.

Specifically, I recommend that DEQ allocate the maximum allowable amount (15%) of the funds for electric vehicle charging infrastructure and installations. And I encourage DEQ to prioritize electric vehicles and buses for replacement whenever possible with the other 85% of the settlement funds. Doing so will maximize the local economic impact and the reduction of air pollution.

I encourage you to not use the funding for natural gas, propane or diesel vehicles. Further dependence on fossil fuels means more pollution. Only a transition to electric vehicles and investment in EV infrastructure will put us on the road to a 100% clean transportation sector in North Carolina.

Sincerely,

Jenafur Maher-Bernard
4323 Mantua Way
Jenafur, NC 27604
jmaherbernard@gmail.com
(919) 602-8903

This message was sent by KnowWho, as a service provider only, on behalf of the individual noted in the sender information.

From: Eric Zimdars (ezimdars@gmail.com) Sent You a Personal Message
To: [daq.NC_VWGrants](#)
Subject: [External] Use Volkswagen funds to electrify NC transportation
Date: Tuesday, December 05, 2017 6:02:45 PM

CAUTION: External email. Do not click links or open attachments unless verified. Send all suspicious email as an attachment to report.spam@nc.gov.

Dear Division of Air Quality,

I am writing to urge DEQ to wisely invest the \$92 million in Volkswagen settlement funds in electric vehicles and infrastructure. Taking advantage of these funds to jumpstart the electrification of North Carolina's transportation sector will mean less money sent out of state for petroleum, more in-state jobs, and cleaner air.

Specifically, I recommend that DEQ allocate the maximum allowable amount (15%) of the funds for electric vehicle charging infrastructure and installations. And I encourage DEQ to prioritize electric vehicles and buses for replacement whenever possible with the other 85% of the settlement funds. Doing so will maximize the local economic impact and the reduction of air pollution.

I encourage you to not use the funding for natural gas, propane or diesel vehicles. Further dependence on fossil fuels means more pollution. Only a transition to electric vehicles and investment in EV infrastructure will put us on the road to a 100% clean transportation sector in North Carolina.

Sincerely,

Eric Zimdars
900 Vista Lake Drive
Candler, NC 28715
ezimdars@gmail.com
(706) 206-2311

This message was sent by KnowWho, as a service provider only, on behalf of the individual noted in the sender information.

From: Martha Brimm (mcb44444@aol.com) Sent You a Personal Message
To: [daq.NC_VWGrants](#)
Subject: [External] Use Volkswagen funds to electrify NC transportation
Date: Tuesday, December 05, 2017 6:01:20 PM

CAUTION: External email. Do not click links or open attachments unless verified. Send all suspicious email as an attachment to report.spam@nc.gov.

Dear Division of Air Quality,

I am writing to urge DEQ to wisely invest the \$92 million in Volkswagen settlement funds in electric vehicles and infrastructure. Taking advantage of these funds to jumpstart the electrification of North Carolina's transportation sector will mean less money sent out of state for petroleum, more in-state jobs, and cleaner air.

Specifically, I recommend that DEQ allocate the maximum allowable amount (15%) of the funds for electric vehicle charging infrastructure and installations. And I encourage DEQ to prioritize electric vehicles and buses for replacement whenever possible with the other 85% of the settlement funds. Doing so will maximize the local economic impact and the reduction of air pollution.

I encourage you to not use the funding for natural gas, propane or diesel vehicles. Further dependence on fossil fuels means more pollution. Only a transition to electric vehicles and investment in EV infrastructure will put us on the road to a 100% clean transportation sector in North Carolina.

Sincerely,

Martha Brimm
7 Surrey Lane
Durham, NC 27707
mcb44444@aol.com
(919) 493-1775

This message was sent by KnowWho, as a service provider only, on behalf of the individual noted in the sender information.

From: Kenneth Johns (kajohns55@yahoo.com) Sent You a Personal Message
To: [daq.NC_VWGrants](#)
Subject: [External] Use Volkswagen funds to electrify NC transportation
Date: Tuesday, December 05, 2017 5:59:43 PM

CAUTION: External email. Do not click links or open attachments unless verified. Send all suspicious email as an attachment to report.spam@nc.gov.

Dear Division of Air Quality,

I am writing to urge DEQ to wisely invest the \$92 million in Volkswagen settlement funds in electric vehicles and infrastructure. Taking advantage of these funds to jumpstart the electrification of North Carolina's transportation sector will mean less money sent out of state for petroleum, more in-state jobs, and cleaner air.

Specifically, I recommend that DEQ allocate the maximum allowable amount (15%) of the funds for electric vehicle charging infrastructure and installations. And I encourage DEQ to prioritize electric vehicles and buses for replacement whenever possible with the other 85% of the settlement funds. Doing so will maximize the local economic impact and the reduction of air pollution.

I encourage you to not use the funding for natural gas, propane or diesel vehicles. Further dependence on fossil fuels means more pollution. Only a transition to electric vehicles and investment in EV infrastructure will put us on the road to a 100% clean transportation sector in North Carolina.

Sincerely,

Kenneth Johns
122 Club House Dr, 2
New London, NC 28127
kajohns55@yahoo.com
(336) 917-9594

This message was sent by KnowWho, as a service provider only, on behalf of the individual noted in the sender information.

From: Harold Smith (haroldmarshallsmith@gmail.com) Sent You a Personal Message
To: daq.NC_VWGrants
Subject: [External] Use Volkswagen funds to electrify NC transportation
Date: Tuesday, December 05, 2017 5:57:26 PM

CAUTION: External email. Do not click links or open attachments unless verified. Send all suspicious email as an attachment to report.spam@nc.gov.

Dear Division of Air Quality,

I am writing to urge DEQ to wisely invest the \$92 million in Volkswagen settlement funds in electric vehicles and infrastructure. Taking advantage of these funds to jumpstart the electrification of North Carolina's transportation sector will mean less money sent out of state for petroleum, more in-state jobs, and cleaner air.

Specifically, I recommend that DEQ allocate the maximum allowable amount (15%) of the funds for electric vehicle charging infrastructure and installations. And I encourage DEQ to prioritize electric vehicles and buses for replacement whenever possible with the other 85% of the settlement funds. Doing so will maximize the local economic impact and the reduction of air pollution.

I encourage you to not use the funding for natural gas, propane or diesel vehicles. Further dependence on fossil fuels means more pollution. Only a transition to electric vehicles and investment in EV infrastructure will put us on the road to a 100% clean transportation sector in North Carolina.

Sincerely,

Harold Smith
600 Merrimon Ave
Asheville, NC 28804
haroldmarshallsmith@gmail.com
(434) 466-3511

This message was sent by KnowWho, as a service provider only, on behalf of the individual noted in the sender information.

From: Daniel Graham (grahamdn@bellsouth.net) Sent You a Personal Message
To: [daq.NC_VWGrants](#)
Subject: [External] Use Volkswagen funds to electrify NC transportation
Date: Tuesday, December 05, 2017 5:51:32 PM

CAUTION: External email. Do not click links or open attachments unless verified. Send all suspicious email as an attachment to report.spam@nc.gov.

Dear Division of Air Quality,

I am writing to urge DEQ to wisely invest the \$92 million in Volkswagen settlement funds in electric vehicles and infrastructure. Taking advantage of these funds to jumpstart the electrification of North Carolina's transportation sector will mean less money sent out of state for petroleum, more in-state jobs, and cleaner air.

Specifically, I recommend that DEQ allocate the maximum allowable amount (15%) of the funds for electric vehicle charging infrastructure and installations. And I encourage DEQ to prioritize electric vehicles and buses for replacement whenever possible with the other 85% of the settlement funds. Doing so will maximize the local economic impact and the reduction of air pollution.

I encourage you to not use the funding for natural gas, propane or diesel vehicles. Further dependence on fossil fuels means more pollution. Only a transition to electric vehicles and investment in EV infrastructure will put us on the road to a 100% clean transportation sector in North Carolina.

Sincerely,

Daniel Graham
123 Grace Ave.
Chapel Hill, NC 27517
grahamdn@bellsouth.net
(919) 942-1759

This message was sent by KnowWho, as a service provider only, on behalf of the individual noted in the sender information.

From: Mary Loughlin (cleolion@aol.com) Sent You a Personal Message
To: [daq.NC_VWGrants](#)
Subject: [External] Use Volkswagen funds to electrify NC transportation
Date: Tuesday, December 05, 2017 5:51:25 PM

CAUTION: External email. Do not click links or open attachments unless verified. Send all suspicious email as an attachment to report.spam@nc.gov.

Dear Division of Air Quality,

I am writing to urge DEQ to wisely invest the \$92 million in Volkswagen settlement funds in electric vehicles and infrastructure. Taking advantage of these funds to jumpstart the electrification of North Carolina's transportation sector will mean less money sent out of state for petroleum, more in-state jobs, and cleaner air.

Specifically, I recommend that DEQ allocate the maximum allowable amount (15%) of the funds for electric vehicle charging infrastructure and installations. And I encourage DEQ to prioritize electric vehicles and buses for replacement whenever possible with the other 85% of the settlement funds. Doing so will maximize the local economic impact and the reduction of air pollution.

I encourage you to not use the funding for natural gas, propane or diesel vehicles. Further dependence on fossil fuels means more pollution. Only a transition to electric vehicles and investment in EV infrastructure will put us on the road to a 100% clean transportation sector in North Carolina.

Sincerely,

Mary Loughlin
4703 Old River Rd
Canton, NC 28716
cleolion@aol.com
(828) 646-0466

This message was sent by KnowWho, as a service provider only, on behalf of the individual noted in the sender information.

From: Robert Lewis (rboxer10@yahoo.com) Sent You a Personal Message
To: [daq.NC_VWGrants](#)
Subject: [External] Use Volkswagen funds to electrify NC transportation
Date: Tuesday, December 05, 2017 5:51:03 PM

CAUTION: External email. Do not click links or open attachments unless verified. Send all suspicious email as an attachment to report.spam@nc.gov.

Dear Division of Air Quality,

I am writing to urge DEQ to wisely invest the \$92 million in Volkswagen settlement funds in electric vehicles and infrastructure. Taking advantage of these funds to jumpstart the electrification of North Carolina's transportation sector will mean less money sent out of state for petroleum, more in-state jobs, and cleaner air.

Specifically, I recommend that DEQ allocate the maximum allowable amount (15%) of the funds for electric vehicle charging infrastructure and installations. And I encourage DEQ to prioritize electric vehicles and buses for replacement whenever possible with the other 85% of the settlement funds. Doing so will maximize the local economic impact and the reduction of air pollution.

I encourage you to not use the funding for natural gas, propane or diesel vehicles. Further dependence on fossil fuels means more pollution. Only a transition to electric vehicles and investment in EV infrastructure will put us on the road to a 100% clean transportation sector in North Carolina.

Sincerely,

Robert Lewis
107 Casey st
Elizabeth City, NC 27909
rboxer10@yahoo.com
(607) 244-8660

This message was sent by KnowWho, as a service provider only, on behalf of the individual noted in the sender information.

From: Patrick Medlin (plmedli@gmail.com) Sent You a Personal Message
To: [daq.NC_VWGrants](#)
Subject: [External] Use Volkswagen funds to electrify NC transportation
Date: Tuesday, December 05, 2017 5:48:42 PM

CAUTION: External email. Do not click links or open attachments unless verified. Send all suspicious email as an attachment to report.spam@nc.gov.

Dear Division of Air Quality,

I am writing to urge DEQ to wisely invest the \$92 million in Volkswagen settlement funds in electric vehicles and infrastructure. Taking advantage of these funds to jumpstart the electrification of North Carolina's transportation sector will mean less money sent out of state for petroleum, more in-state jobs, and cleaner air.

Specifically, I recommend that DEQ allocate the maximum allowable amount (15%) of the funds for electric vehicle charging infrastructure and installations. And I encourage DEQ to prioritize electric vehicles and buses for replacement whenever possible with the other 85% of the settlement funds. Doing so will maximize the local economic impact and the reduction of air pollution.

I encourage you to not use the funding for natural gas, propane or diesel vehicles. Further dependence on fossil fuels means more pollution. Only a transition to electric vehicles and investment in EV infrastructure will put us on the road to a 100% clean transportation sector in North Carolina.

Sincerely,

Patrick Medlin
315 MacNeil Way
Weaverville, NC 28787
plmedli@gmail.com
(303) 501-3279

This message was sent by KnowWho, as a service provider only, on behalf of the individual noted in the sender information.

From: Elizabeth Wanner (libwanner@gmail.com) Sent You a Personal Message
To: [daq.NC_VWGrants](#)
Subject: [External] Use Volkswagen funds to electrify NC transportation
Date: Tuesday, December 05, 2017 5:48:18 PM

CAUTION: External email. Do not click links or open attachments unless verified. Send all suspicious email as an attachment to report.spam@nc.gov.

Dear Division of Air Quality,

I am writing to urge DEQ to wisely invest the \$92 million in Volkswagen settlement funds in electric vehicles and infrastructure. Taking advantage of these funds to jumpstart the electrification of North Carolina's transportation sector will mean less money sent out of state for petroleum, more in-state jobs, and cleaner air.

Specifically, I recommend that DEQ allocate the maximum allowable amount (15%) of the funds for electric vehicle charging infrastructure and installations. And I encourage DEQ to prioritize electric vehicles and buses for replacement whenever possible with the other 85% of the settlement funds. Doing so will maximize the local economic impact and the reduction of air pollution.

I encourage you to not use the funding for natural gas, propane or diesel vehicles. Further dependence on fossil fuels means more pollution. Only a transition to electric vehicles and investment in EV infrastructure will put us on the road to a 100% clean transportation sector in North Carolina.

Sincerely,

Elizabeth Wanner
6206 Inland Greens Drive
Wilmington, NC 28405
libwanner@gmail.com
(919) 749-4649

This message was sent by KnowWho, as a service provider only, on behalf of the individual noted in the sender information.

From: Marvin Woll (mjwoll@nc.rr.com) Sent You a Personal Message
To: [daq.NC_VWGrants](#)
Subject: [External] Use Volkswagen funds to electrify NC transportation
Date: Tuesday, December 05, 2017 5:48:05 PM

CAUTION: External email. Do not click links or open attachments unless verified. Send all suspicious email as an attachment to report.spam@nc.gov.

Dear Division of Air Quality,

I am writing to urge DEQ to wisely invest the \$92 million in Volkswagen settlement funds in electric vehicles and infrastructure. Taking advantage of these funds to jumpstart the electrification of North Carolina's transportation sector will mean less money sent out of state for petroleum, more in-state jobs, and cleaner air.

Specifically, I recommend that DEQ allocate the maximum allowable amount (15%) of the funds for electric vehicle charging infrastructure and installations. And I encourage DEQ to prioritize electric vehicles and buses for replacement whenever possible with the other 85% of the settlement funds. Doing so will maximize the local economic impact and the reduction of air pollution.

I encourage you to not use the funding for natural gas, propane or diesel vehicles. Further dependence on fossil fuels means more pollution. Only a transition to electric vehicles and investment in EV infrastructure will put us on the road to a 100% clean transportation sector in North Carolina.

Sincerely,

Marvin Woll
1116 Vannstone Dr.
Raleigh, NC 27603
mjwoll@nc.rr.com
(919) 771-0888

This message was sent by KnowWho, as a service provider only, on behalf of the individual noted in the sender information.

From: Sharon Godfrey (sharongodfrey25@gmail.com) Sent You a Personal Message
To: [daq.NC_VWGrants](#)
Subject: [External] Use Volkswagen funds to electrify NC transportation
Date: Tuesday, December 05, 2017 5:47:19 PM

CAUTION: External email. Do not click links or open attachments unless verified. Send all suspicious email as an attachment to report.spam@nc.gov.

Dear Division of Air Quality,

I am writing to urge DEQ to wisely invest the \$92 million in Volkswagen settlement funds in electric vehicles and infrastructure. Taking advantage of these funds to jumpstart the electrification of North Carolina's transportation sector will mean less money sent out of state for petroleum, more in-state jobs, and cleaner air.

Specifically, I recommend that DEQ allocate the maximum allowable amount (15%) of the funds for electric vehicle charging infrastructure and installations. And I encourage DEQ to prioritize electric vehicles and buses for replacement whenever possible with the other 85% of the settlement funds. Doing so will maximize the local economic impact and the reduction of air pollution.

I encourage you to not use the funding for natural gas, propane or diesel vehicles. Further dependence on fossil fuels means more pollution. Only a transition to electric vehicles and investment in EV infrastructure will put us on the road to a 100% clean transportation sector in North Carolina.

Sincerely,

Sharon Godfrey
9524 Deer Spring Ln.
Charlotte, NC 28210
sharongodfrey25@gmail.com
(704) 541-7332

This message was sent by KnowWho, as a service provider only, on behalf of the individual noted in the sender information.

From: Christine Gerbode (christine.gerbode@gmail.com) Sent You a Personal Message
To: [daq.NC_VWGrants](#)
Subject: [External] Use Volkswagen funds to electrify NC transportation
Date: Tuesday, December 05, 2017 5:45:37 PM

CAUTION: External email. Do not click links or open attachments unless verified. Send all suspicious email as an attachment to report.spam@nc.gov.

Dear Division of Air Quality,

I am writing to urge DEQ to wisely invest the \$92 million in Volkswagen settlement funds in electric vehicles and infrastructure. Taking advantage of these funds to jumpstart the electrification of North Carolina's transportation sector will mean less money sent out of state for petroleum, more in-state jobs, and cleaner air.

Specifically, I recommend that DEQ allocate the maximum allowable amount (15%) of the funds for electric vehicle charging infrastructure and installations. And I encourage DEQ to prioritize electric vehicles and buses for replacement whenever possible with the other 85% of the settlement funds. Doing so will maximize the local economic impact and the reduction of air pollution.

I encourage you to not use the funding for natural gas, propane or diesel vehicles. Further dependence on fossil fuels means more pollution. Only a transition to electric vehicles and investment in EV infrastructure will put us on the road to a 100% clean transportation sector in North Carolina.

Sincerely,

Christine Gerbode
1505 Duke University Rd., Apt. 2H
Durham, NC 27701
christine.gerbode@gmail.com
(832) 483-5420

This message was sent by KnowWho, as a service provider only, on behalf of the individual noted in the sender information.

From: Brent Hassell (hassell_2@msn.com) Sent You a Personal Message
To: [daq.NC_VWGrants](#)
Subject: [External] Use Volkswagen funds to electrify NC transportation
Date: Tuesday, December 05, 2017 5:45:34 PM

CAUTION: External email. Do not click links or open attachments unless verified. Send all suspicious email as an attachment to report.spam@nc.gov.

Dear Division of Air Quality,

I am writing to urge DEQ to wisely invest the \$92 million in Volkswagen settlement funds in electric vehicles and infrastructure. Taking advantage of these funds to jumpstart the electrification of North Carolina's transportation sector will mean less money sent out of state for petroleum, more in-state jobs, and cleaner air.

Specifically, I recommend that DEQ allocate the maximum allowable amount (15%) of the funds for electric vehicle charging infrastructure and installations. And I encourage DEQ to prioritize electric vehicles and buses for replacement whenever possible with the other 85% of the settlement funds. Doing so will maximize the local economic impact and the reduction of air pollution.

I encourage you to not use the funding for natural gas, propane or diesel vehicles. Further dependence on fossil fuels means more pollution. Only a transition to electric vehicles and investment in EV infrastructure will put us on the road to a 100% clean transportation sector in North Carolina.

Sincerely,

Brent Hassell
880 Lakecrest Ave
High Point, NC 27265
hassell_2@msn.com
(336) 491-3102

This message was sent by KnowWho, as a service provider only, on behalf of the individual noted in the sender information.

From: Emily Shepard (eshepardus@yahoo.com) Sent You a Personal Message
To: [daq.NC_VWGrants](#)
Subject: [External] Use Volkswagen funds to electrify NC transportation
Date: Tuesday, December 05, 2017 5:44:11 PM

CAUTION: External email. Do not click links or open attachments unless verified. Send all suspicious email as an attachment to report.spam@nc.gov.

Dear Division of Air Quality,

I am writing to urge DEQ to wisely invest the \$92 million in Volkswagen settlement funds in electric vehicles and infrastructure. Taking advantage of these funds to jumpstart the electrification of North Carolina's transportation sector will mean less money sent out of state for petroleum, more in-state jobs, and cleaner air.

Specifically, I recommend that DEQ allocate the maximum allowable amount (15%) of the funds for electric vehicle charging infrastructure and installations. And I encourage DEQ to prioritize electric vehicles and buses for replacement whenever possible with the other 85% of the settlement funds. Doing so will maximize the local economic impact and the reduction of air pollution.

I encourage you to not use the funding for natural gas, propane or diesel vehicles. Further dependence on fossil fuels means more pollution. Only a transition to electric vehicles and investment in EV infrastructure will put us on the road to a 100% clean transportation sector in North Carolina.

Sincerely,

Emily Shepard
8663 Holman Mill Road
Snow Camp, NC 27349
eshepardus@yahoo.com
(336) 376-9046

This message was sent by KnowWho, as a service provider only, on behalf of the individual noted in the sender information.

From: Charles Gallagher (gaperf160@aol.com) Sent You a Personal Message
To: [daq.NC_VWGrants](#)
Subject: [External] Use Volkswagen funds to electrify NC transportation
Date: Tuesday, December 05, 2017 5:43:48 PM

CAUTION: External email. Do not click links or open attachments unless verified. Send all suspicious email as an attachment to report.spam@nc.gov.

Dear Division of Air Quality,

I am writing to urge DEQ to wisely invest the \$92 million in Volkswagen settlement funds in electric vehicles and infrastructure. Taking advantage of these funds to jumpstart the electrification of North Carolina's transportation sector will mean less money sent out of state for petroleum, more in-state jobs, and cleaner air.

Specifically, I recommend that DEQ allocate the maximum allowable amount (15%) of the funds for electric vehicle charging infrastructure and installations. And I encourage DEQ to prioritize electric vehicles and buses for replacement whenever possible with the other 85% of the settlement funds. Doing so will maximize the local economic impact and the reduction of air pollution.

I encourage you to not use the funding for natural gas, propane or diesel vehicles. Further dependence on fossil fuels means more pollution. Only a transition to electric vehicles and investment in EV infrastructure will put us on the road to a 100% clean transportation sector in North Carolina.

Sincerely,

Charles Gallagher
311 ASHWOOD LN
LEXINGTON, NC 27295
gaperf160@aol.com
(336) 775-4321

This message was sent by KnowWho, as a service provider only, on behalf of the individual noted in the sender information.

From: Jeffrey Deal (jeffrey.g.deal@gmail.com) Sent You a Personal Message
To: [daq.NC_VWGrants](#)
Subject: [External] Use Volkswagen funds to electrify NC transportation
Date: Tuesday, December 05, 2017 5:42:42 PM

CAUTION: External email. Do not click links or open attachments unless verified. Send all suspicious email as an attachment to report.spam@nc.gov.

Dear Division of Air Quality,

I am writing to urge DEQ to wisely invest the \$92 million in Volkswagen settlement funds in electric vehicles and infrastructure. Taking advantage of these funds to jumpstart the electrification of North Carolina's transportation sector will mean less money sent out of state for petroleum, more in-state jobs, and cleaner air.

Specifically, I recommend that DEQ allocate the maximum allowable amount (15%) of the funds for electric vehicle charging infrastructure and installations. And I encourage DEQ to prioritize electric vehicles and buses for replacement whenever possible with the other 85% of the settlement funds. Doing so will maximize the local economic impact and the reduction of air pollution.

I encourage you to not use the funding for natural gas, propane or diesel vehicles. Further dependence on fossil fuels means more pollution. Only a transition to electric vehicles and investment in EV infrastructure will put us on the road to a 100% clean transportation sector in North Carolina.

Sincerely,

Jeffrey Deal
220 Tall Timber Trail
Boone, NC 28607
jeffrey.g.deal@gmail.com
(828) 406-2335

This message was sent by KnowWho, as a service provider only, on behalf of the individual noted in the sender information.

From: Nicole Gadon (nicole.gadon@gmail.com) Sent You a Personal Message
To: [daq.NC_VWGrants](#)
Subject: [External] Use Volkswagen funds to electrify NC transportation
Date: Tuesday, December 05, 2017 5:42:40 PM

CAUTION: External email. Do not click links or open attachments unless verified. Send all suspicious email as an attachment to report.spam@nc.gov.

Dear Division of Air Quality,

I am writing to urge DEQ to wisely invest the \$92 million in Volkswagen settlement funds in electric vehicles and infrastructure. Taking advantage of these funds to jumpstart the electrification of North Carolina's transportation sector will mean less money sent out of state for petroleum, more in-state jobs, and cleaner air.

Specifically, I recommend that DEQ allocate the maximum allowable amount (15%) of the funds for electric vehicle charging infrastructure and installations. And I encourage DEQ to prioritize electric vehicles and buses for replacement whenever possible with the other 85% of the settlement funds. Doing so will maximize the local economic impact and the reduction of air pollution.

I encourage you to not use the funding for natural gas, propane or diesel vehicles. Further dependence on fossil fuels means more pollution. Only a transition to electric vehicles and investment in EV infrastructure will put us on the road to a 100% clean transportation sector in North Carolina.

Sincerely,

Nicole Gadon
60 Madison Ave
Asheville, NC 28801
nicole.gadon@gmail.com
(646) 296-7829

This message was sent by KnowWho, as a service provider only, on behalf of the individual noted in the sender information.

From: Mary Rand (mbridgers7@gmail.com) Sent You a Personal Message
To: [daq.NC_VWGrants](#)
Subject: [External] Use Volkswagen funds to electrify NC transportation
Date: Tuesday, December 05, 2017 5:42:16 PM

CAUTION: External email. Do not click links or open attachments unless verified. Send all suspicious email as an attachment to report.spam@nc.gov.

Dear Division of Air Quality,

I am writing to urge DEQ to wisely invest the \$92 million in Volkswagen settlement funds in electric vehicles and infrastructure. Taking advantage of these funds to jumpstart the electrification of North Carolina's transportation sector will mean less money sent out of state for petroleum, more in-state jobs, and cleaner air.

Specifically, I recommend that DEQ allocate the maximum allowable amount (15%) of the funds for electric vehicle charging infrastructure and installations. And I encourage DEQ to prioritize electric vehicles and buses for replacement whenever possible with the other 85% of the settlement funds. Doing so will maximize the local economic impact and the reduction of air pollution.

I encourage you to not use the funding for natural gas, propane or diesel vehicles. Further dependence on fossil fuels means more pollution. Only a transition to electric vehicles and investment in EV infrastructure will put us on the road to a 100% clean transportation sector in North Carolina.

Sincerely,

Mary Rand
1205 Old Coats Rd
Lillington, NC 27546
mbridgers7@gmail.com
(910) 814-0710

This message was sent by KnowWho, as a service provider only, on behalf of the individual noted in the sender information.

From: Dell Ponow (daponow5@gmail.com) Sent You a Personal Message
To: [daq.NC_VWGrants](#)
Subject: [External] Use Volkswagen funds to electrify NC transportation
Date: Tuesday, December 05, 2017 5:41:56 PM

CAUTION: External email. Do not click links or open attachments unless verified. Send all suspicious email as an attachment to report.spam@nc.gov.

Dear Division of Air Quality,

I am writing to urge DEQ to wisely invest the \$92 million in Volkswagen settlement funds in electric vehicles and infrastructure. Taking advantage of these funds to jumpstart the electrification of North Carolina's transportation sector will mean less money sent out of state for petroleum, more in-state jobs, and cleaner air.

Specifically, I recommend that DEQ allocate the maximum allowable amount (15%) of the funds for electric vehicle charging infrastructure and installations. And I encourage DEQ to prioritize electric vehicles and buses for replacement whenever possible with the other 85% of the settlement funds. Doing so will maximize the local economic impact and the reduction of air pollution.

I encourage you to not use the funding for natural gas, propane or diesel vehicles. Further dependence on fossil fuels means more pollution. Only a transition to electric vehicles and investment in EV infrastructure will put us on the road to a 100% clean transportation sector in North Carolina.

Sincerely,

Dell Ponow
351 Wimbish rd.
Eden, NC 27288
daponow5@gmail.com
(336) 623-1521

This message was sent by KnowWho, as a service provider only, on behalf of the individual noted in the sender information.

From: Peggy Braxton (pwbraxton@gmail.com) Sent You a Personal Message
To: [daq.NC_VWGrants](#)
Subject: [External] Use Volkswagen funds to electrify NC transportation
Date: Tuesday, December 05, 2017 5:41:42 PM

CAUTION: External email. Do not click links or open attachments unless verified. Send all suspicious email as an attachment to report.spam@nc.gov.

Dear Division of Air Quality,

I am writing to urge DEQ to wisely invest the \$92 million in Volkswagen settlement funds in electric vehicles and infrastructure. Taking advantage of these funds to jumpstart the electrification of North Carolina's transportation sector will mean less money sent out of state for petroleum, more in-state jobs, and cleaner air.

Specifically, I recommend that DEQ allocate the maximum allowable amount (15%) of the funds for electric vehicle charging infrastructure and installations. And I encourage DEQ to prioritize electric vehicles and buses for replacement whenever possible with the other 85% of the settlement funds. Doing so will maximize the local economic impact and the reduction of air pollution.

I encourage you to not use the funding for natural gas, propane or diesel vehicles. Further dependence on fossil fuels means more pollution. Only a transition to electric vehicles and investment in EV infrastructure will put us on the road to a 100% clean transportation sector in North Carolina.

Sincerely,

Peggy Braxton
P O Box 383
Maury, NC 28554
pwbraxton@gmail.com
(252) 560-1728

This message was sent by KnowWho, as a service provider only, on behalf of the individual noted in the sender information.

From: William Gardner (wngardner@juno.com) Sent You a Personal Message
To: [daq.NC_VWGrants](#)
Subject: [External] Use Volkswagen funds to electrify NC transportation
Date: Tuesday, December 05, 2017 5:40:19 PM

CAUTION: External email. Do not click links or open attachments unless verified. Send all suspicious email as an attachment to report.spam@nc.gov.

Dear Division of Air Quality,

I am writing to urge DEQ to wisely invest the \$92 million in Volkswagen settlement funds in electric vehicles and infrastructure. Taking advantage of these funds to jumpstart the electrification of North Carolina's transportation sector will mean less money sent out of state for petroleum, more in-state jobs, and cleaner air.

Specifically, I recommend that DEQ allocate the maximum allowable amount (15%) of the funds for electric vehicle charging infrastructure and installations. And I encourage DEQ to prioritize electric vehicles and buses for replacement whenever possible with the other 85% of the settlement funds. Doing so will maximize the local economic impact and the reduction of air pollution.

I encourage you to not use the funding for natural gas, propane or diesel vehicles. Further dependence on fossil fuels means more pollution. Only a transition to electric vehicles and investment in EV infrastructure will put us on the road to a 100% clean transportation sector in North Carolina.

Sincerely,

William Gardner
5500 Fortunes Ridge Drive 95C
Durham, NC 27713
wngardner@juno.com
(919) 973-4057

This message was sent by KnowWho, as a service provider only, on behalf of the individual noted in the sender information.

From: Kathryn Davis (kldavis302@gmail.com) Sent You a Personal Message
To: [daq.NC_VWGrants](#)
Subject: [External] Use Volkswagen funds to electrify NC transportation
Date: Tuesday, December 05, 2017 5:39:22 PM

CAUTION: External email. Do not click links or open attachments unless verified. Send all suspicious email as an attachment to report.spam@nc.gov.

Dear Division of Air Quality,

I am writing to urge DEQ to wisely invest the \$92 million in Volkswagen settlement funds in electric vehicles and infrastructure. Taking advantage of these funds to jumpstart the electrification of North Carolina's transportation sector will mean less money sent out of state for petroleum, more in-state jobs, and cleaner air.

Specifically, I recommend that DEQ allocate the maximum allowable amount (15%) of the funds for electric vehicle charging infrastructure and installations. And I encourage DEQ to prioritize electric vehicles and buses for replacement whenever possible with the other 85% of the settlement funds. Doing so will maximize the local economic impact and the reduction of air pollution.

I encourage you to not use the funding for natural gas, propane or diesel vehicles. Further dependence on fossil fuels means more pollution. Only a transition to electric vehicles and investment in EV infrastructure will put us on the road to a 100% clean transportation sector in North Carolina.

Sincerely,

Kathryn Davis
302 W Monroe St
Salisbury, NC 28144
kldavis302@gmail.com
(703) 217-1027

This message was sent by KnowWho, as a service provider only, on behalf of the individual noted in the sender information.

From: Carie Hudson (cariehudson@gmail.com) Sent You a Personal Message
To: [daq.NC_VWGrants](#)
Subject: [External] Use Volkswagen funds to electrify NC transportation
Date: Tuesday, December 05, 2017 5:37:59 PM

CAUTION: External email. Do not click links or open attachments unless verified. Send all suspicious email as an attachment to report.spam@nc.gov.

Dear Division of Air Quality,

I am writing to urge DEQ to wisely invest the \$92 million in Volkswagen settlement funds in electric vehicles and infrastructure. Taking advantage of these funds to jumpstart the electrification of North Carolina's transportation sector will mean less money sent out of state for petroleum, more in-state jobs, and cleaner air.

Specifically, I recommend that DEQ allocate the maximum allowable amount (15%) of the funds for electric vehicle charging infrastructure and installations. And I encourage DEQ to prioritize electric vehicles and buses for replacement whenever possible with the other 85% of the settlement funds. Doing so will maximize the local economic impact and the reduction of air pollution.

I encourage you to not use the funding for natural gas, propane or diesel vehicles. Further dependence on fossil fuels means more pollution. Only a transition to electric vehicles and investment in EV infrastructure will put us on the road to a 100% clean transportation sector in North Carolina.

Sincerely,

Carie Hudson
123 Balsam Court
Chapel hill, NC 27513
cariehudson@gmail.com
(919) 265-3926

This message was sent by KnowWho, as a service provider only, on behalf of the individual noted in the sender information.

From: Lawrence Turk, RN (butch@wildrockies.org) Sent You a Personal Message
To: daq.NC_VWGrants
Subject: [External] Use Volkswagen funds to electrify NC transportation
Date: Tuesday, December 05, 2017 5:37:47 PM

CAUTION: External email. Do not click links or open attachments unless verified. Send all suspicious email as an attachment to report.spam@nc.gov.

Dear Division of Air Quality,

I am writing to urge DEQ to wisely invest the \$92 million in Volkswagen settlement funds in electric vehicles and infrastructure. Taking advantage of these funds to jumpstart the electrification of North Carolina's transportation sector will mean less money sent out of state for petroleum, more in-state jobs, and cleaner air.

Specifically, I recommend that DEQ allocate the maximum allowable amount (15%) of the funds for electric vehicle charging infrastructure and installations. And I encourage DEQ to prioritize electric vehicles and buses for replacement whenever possible with the other 85% of the settlement funds. Doing so will maximize the local economic impact and the reduction of air pollution.

I encourage you to not use the funding for natural gas, propane or diesel vehicles. Further dependence on fossil fuels means more pollution. Only a transition to electric vehicles and investment in EV infrastructure will put us on the road to a 100% clean transportation sector in North Carolina.

Sincerely,

Lawrence Turk, RN
POB 203
Hendersonville, NC 28793
butch@wildrockies.org
(555) 555-5555

This message was sent by KnowWho, as a service provider only, on behalf of the individual noted in the sender information.

From: Jean Patterson (jeanpatterson311@gmail.com) Sent You a Personal Message
To: [daq.NC_VWGrants](#)
Subject: [External] Use Volkswagen funds to electrify NC transportation
Date: Tuesday, December 05, 2017 5:37:20 PM

CAUTION: External email. Do not click links or open attachments unless verified. Send all suspicious email as an attachment to report.spam@nc.gov.

Dear Division of Air Quality,

I am writing to urge DEQ to wisely invest the \$92 million in Volkswagen settlement funds in electric vehicles and infrastructure. Taking advantage of these funds to jumpstart the electrification of North Carolina's transportation sector will mean less money sent out of state for petroleum, more in-state jobs, and cleaner air.

Specifically, I recommend that DEQ allocate the maximum allowable amount (15%) of the funds for electric vehicle charging infrastructure and installations. And I encourage DEQ to prioritize electric vehicles and buses for replacement whenever possible with the other 85% of the settlement funds. Doing so will maximize the local economic impact and the reduction of air pollution.

I encourage you to not use the funding for natural gas, propane or diesel vehicles. Further dependence on fossil fuels means more pollution. Only a transition to electric vehicles and investment in EV infrastructure will put us on the road to a 100% clean transportation sector in North Carolina.

Sincerely,

Jean Patterson
7315 Terrace dr
Charlotte, NC 28211
jeanpatterson311@gmail.com
(704) 258-2473

This message was sent by KnowWho, as a service provider only, on behalf of the individual noted in the sender information.

From: Mary Goodkind (mary@lindleyg.com) Sent You a Personal Message
To: [daq.NC_VWGrants](#)
Subject: [External] Use Volkswagen funds to electrify NC transportation
Date: Tuesday, December 05, 2017 5:35:30 PM

CAUTION: External email. Do not click links or open attachments unless verified. Send all suspicious email as an attachment to report.spam@nc.gov.

Dear Division of Air Quality,

I am writing to urge DEQ to wisely invest the \$92 million in Volkswagen settlement funds in electric vehicles and infrastructure. Taking advantage of these funds to jumpstart the electrification of North Carolina's transportation sector will mean less money sent out of state for petroleum, more in-state jobs, and cleaner air.

Specifically, I recommend that DEQ allocate the maximum allowable amount (15%) of the funds for electric vehicle charging infrastructure and installations. And I encourage DEQ to prioritize electric vehicles and buses for replacement whenever possible with the other 85% of the settlement funds. Doing so will maximize the local economic impact and the reduction of air pollution.

I encourage you to not use the funding for natural gas, propane or diesel vehicles. Further dependence on fossil fuels means more pollution. Only a transition to electric vehicles and investment in EV infrastructure will put us on the road to a 100% clean transportation sector in North Carolina.

Sincerely,

Mary Goodkind
23 Ridgfield Pl
Mary, NC 28803
mary@lindleyg.com
(828) 424-7151

This message was sent by KnowWho, as a service provider only, on behalf of the individual noted in the sender information.

From: Louise Gross (chile96@hotmail.com) Sent You a Personal Message
To: [daq.NC_VWGrants](#)
Subject: [External] Use Volkswagen funds to electrify NC transportation
Date: Tuesday, December 05, 2017 5:33:21 PM

CAUTION: External email. Do not click links or open attachments unless verified. Send all suspicious email as an attachment to report.spam@nc.gov.

Dear Division of Air Quality,

I am writing to urge DEQ to wisely invest the \$92 million in Volkswagen settlement funds in electric vehicles and infrastructure. Taking advantage of these funds to jumpstart the electrification of North Carolina's transportation sector will mean less money sent out of state for petroleum, more in-state jobs, and cleaner air.

Specifically, I recommend that DEQ allocate the maximum allowable amount (15%) of the funds for electric vehicle charging infrastructure and installations. And I encourage DEQ to prioritize electric vehicles and buses for replacement whenever possible with the other 85% of the settlement funds. Doing so will maximize the local economic impact and the reduction of air pollution.

I encourage you to not use the funding for natural gas, propane or diesel vehicles. Further dependence on fossil fuels means more pollution. Only a transition to electric vehicles and investment in EV infrastructure will put us on the road to a 100% clean transportation sector in North Carolina.

Sincerely,

Louise Gross
2601 IDLEBROOK CIR
MIDWAY PARK, NC 28544
chile96@hotmail.com
(910) 353-1700

This message was sent by KnowWho, as a service provider only, on behalf of the individual noted in the sender information.

From: Anne Kepplinger (anne.kepplinger@gmail.com) Sent You a Personal Message
To: [daq.NC_VWGrants](#)
Subject: [External] Use Volkswagen funds to electrify NC transportation
Date: Tuesday, December 05, 2017 5:28:06 PM

CAUTION: External email. Do not click links or open attachments unless verified. Send all suspicious email as an attachment to report.spam@nc.gov.

Dear Division of Air Quality,

I am writing to urge DEQ to wisely invest the \$92 million in Volkswagen settlement funds in electric vehicles and infrastructure. Taking advantage of these funds to jumpstart the electrification of North Carolina's transportation sector will mean less money sent out of state for petroleum, more in-state jobs, and cleaner air.

Specifically, I recommend that DEQ allocate the maximum allowable amount (15%) of the funds for electric vehicle charging infrastructure and installations. And I encourage DEQ to prioritize electric vehicles and buses for replacement whenever possible with the other 85% of the settlement funds. Doing so will maximize the local economic impact and the reduction of air pollution.

I encourage you to not use the funding for natural gas, propane or diesel vehicles. Further dependence on fossil fuels means more pollution. Only a transition to electric vehicles and investment in EV infrastructure will put us on the road to a 100% clean transportation sector in North Carolina.

Sincerely,

Anne Kepplinger
2844 Wycliff Rd Raleigh NC 27607 United States
Raleigh, NC 27607
anne.kepplinger@gmail.com
(919) 649-5608

This message was sent by KnowWho, as a service provider only, on behalf of the individual noted in the sender information.

From: Virginia Baner (vbaner@hotmail.com) Sent You a Personal Message
To: [daq.NC_VWGrants](#)
Subject: [External] Use Volkswagen funds to electrify NC transportation
Date: Tuesday, December 05, 2017 5:27:55 PM

CAUTION: External email. Do not click links or open attachments unless verified. Send all suspicious email as an attachment to report.spam@nc.gov.

Dear Division of Air Quality,

I am writing to urge DEQ to wisely invest the \$92 million in Volkswagen settlement funds in electric vehicles and infrastructure. Taking advantage of these funds to jumpstart the electrification of North Carolina's transportation sector will mean less money sent out of state for petroleum, more in-state jobs, and cleaner air.

Specifically, I recommend that DEQ allocate the maximum allowable amount (15%) of the funds for electric vehicle charging infrastructure and installations. And I encourage DEQ to prioritize electric vehicles and buses for replacement whenever possible with the other 85% of the settlement funds. Doing so will maximize the local economic impact and the reduction of air pollution.

I encourage you to not use the funding for natural gas, propane or diesel vehicles. Further dependence on fossil fuels means more pollution. Only a transition to electric vehicles and investment in EV infrastructure will put us on the road to a 100% clean transportation sector in North Carolina.

Sincerely,

Virginia Baner
309 Drexel Farm Drive
Hendersonville, NC 28739
vbaner@hotmail.com
(828) 890-3481

This message was sent by KnowWho, as a service provider only, on behalf of the individual noted in the sender information.

From: John Evans (hartevans5@gmail.com) Sent You a Personal Message
To: [daq.NC_VWGrants](#)
Subject: [External] Use Volkswagen funds to electrify NC transportation
Date: Tuesday, December 05, 2017 5:27:48 PM

CAUTION: External email. Do not click links or open attachments unless verified. Send all suspicious email as an attachment to report.spam@nc.gov.

Dear Division of Air Quality,

I am writing to urge DEQ to wisely invest the \$92 million in Volkswagen settlement funds in electric vehicles and infrastructure. Taking advantage of these funds to jumpstart the electrification of North Carolina's transportation sector will mean less money sent out of state for petroleum, more in-state jobs, and cleaner air.

Specifically, I recommend that DEQ allocate the maximum allowable amount (15%) of the funds for electric vehicle charging infrastructure and installations. And I encourage DEQ to prioritize electric vehicles and buses for replacement whenever possible with the other 85% of the settlement funds. Doing so will maximize the local economic impact and the reduction of air pollution.

I encourage you to not use the funding for natural gas, propane or diesel vehicles. Further dependence on fossil fuels means more pollution. Only a transition to electric vehicles and investment in EV infrastructure will put us on the road to a 100% clean transportation sector in North Carolina.

Sincerely,

John Evans
109 Appleton Drive
Roanoke Rapids, NC 27870
hartevans5@gmail.com
(252) 903-9157

This message was sent by KnowWho, as a service provider only, on behalf of the individual noted in the sender information.

From: Fred Putnam (fhputnam@aol.com) Sent You a Personal Message
To: [daq.NC_VWGrants](#)
Subject: [External] Use Volkswagen funds to electrify NC transportation
Date: Tuesday, December 05, 2017 5:27:09 PM

CAUTION: External email. Do not click links or open attachments unless verified. Send all suspicious email as an attachment to report.spam@nc.gov.

Dear Division of Air Quality,

I am writing to urge DEQ to wisely invest the \$92 million in Volkswagen settlement funds in electric vehicles and infrastructure. Taking advantage of these funds to jumpstart the electrification of North Carolina's transportation sector will mean less money sent out of state for petroleum, more in-state jobs, and cleaner air.

Specifically, I recommend that DEQ allocate the maximum allowable amount (15%) of the funds for electric vehicle charging infrastructure and installations. And I encourage DEQ to prioritize electric vehicles and buses for replacement whenever possible with the other 85% of the settlement funds. Doing so will maximize the local economic impact and the reduction of air pollution.

I encourage you to not use the funding for natural gas, propane or diesel vehicles. Further dependence on fossil fuels means more pollution. Only a transition to electric vehicles and investment in EV infrastructure will put us on the road to a 100% clean transportation sector in North Carolina.

Sincerely,

Fred Putnam
306 Dutchman Avenue
Mount Holly, NC 28120
fhputnam@aol.com
(704) 827-4730

This message was sent by KnowWho, as a service provider only, on behalf of the individual noted in the sender information.

From: Rachel Galper (rinahrising@gmail.com) Sent You a Personal Message
To: [daq.NC_VWGrants](#)
Subject: [External] Use Volkswagen funds to electrify NC transportation
Date: Tuesday, December 05, 2017 5:27:09 PM

CAUTION: External email. Do not click links or open attachments unless verified. Send all suspicious email as an attachment to report.spam@nc.gov.

Dear Division of Air Quality,

I am writing to urge DEQ to wisely invest the \$92 million in Volkswagen settlement funds in electric vehicles and infrastructure. Taking advantage of these funds to jumpstart the electrification of North Carolina's transportation sector will mean less money sent out of state for petroleum, more in-state jobs, and cleaner air.

Specifically, I recommend that DEQ allocate the maximum allowable amount (15%) of the funds for electric vehicle charging infrastructure and installations. And I encourage DEQ to prioritize electric vehicles and buses for replacement whenever possible with the other 85% of the settlement funds. Doing so will maximize the local economic impact and the reduction of air pollution.

I encourage you to not use the funding for natural gas, propane or diesel vehicles. Further dependence on fossil fuels means more pollution. Only a transition to electric vehicles and investment in EV infrastructure will put us on the road to a 100% clean transportation sector in North Carolina.

Sincerely,

Rachel Galper
1107 9th Street
Durham, NC 27705
rinahrising@gmail.com
(646) 241-7555

This message was sent by KnowWho, as a service provider only, on behalf of the individual noted in the sender information.

From: Allyn Howlett (allyn-babyo@hotmail.com) Sent You a Personal Message
To: [daq.NC_VWGrants](#)
Subject: [External] Use Volkswagen funds to electrify NC transportation
Date: Tuesday, December 05, 2017 5:27:08 PM

CAUTION: External email. Do not click links or open attachments unless verified. Send all suspicious email as an attachment to report.spam@nc.gov.

Dear Division of Air Quality,

I am writing to urge DEQ to wisely invest the \$92 million in Volkswagen settlement funds in electric vehicles and infrastructure. Taking advantage of these funds to jumpstart the electrification of North Carolina's transportation sector will mean less money sent out of state for petroleum, more in-state jobs, and cleaner air.

Specifically, I recommend that DEQ allocate the maximum allowable amount (15%) of the funds for electric vehicle charging infrastructure and installations. And I encourage DEQ to prioritize electric vehicles and buses for replacement whenever possible with the other 85% of the settlement funds. Doing so will maximize the local economic impact and the reduction of air pollution.

I encourage you to not use the funding for natural gas, propane or diesel vehicles. Further dependence on fossil fuels means more pollution. Only a transition to electric vehicles and investment in EV infrastructure will put us on the road to a 100% clean transportation sector in North Carolina.

Sincerely,

Allyn Howlett
672 cook school rd
Pilot Mountain, NC 27041
allyn-babyo@hotmail.com
(336) 351-2814

This message was sent by KnowWho, as a service provider only, on behalf of the individual noted in the sender information.

From: Jeremy Stubbs (stubbs1493@msn.com) Sent You a Personal Message
To: [daq.NC_VWGrants](#)
Subject: [External] Use Volkswagen funds to electrify NC transportation
Date: Tuesday, December 05, 2017 5:26:33 PM

CAUTION: External email. Do not click links or open attachments unless verified. Send all suspicious email as an attachment to report.spam@nc.gov.

Dear Division of Air Quality,

I am writing to urge DEQ to wisely invest the \$92 million in Volkswagen settlement funds in electric vehicles and infrastructure. Taking advantage of these funds to jumpstart the electrification of North Carolina's transportation sector will mean less money sent out of state for petroleum, more in-state jobs, and cleaner air.

Specifically, I recommend that DEQ allocate the maximum allowable amount (15%) of the funds for electric vehicle charging infrastructure and installations. And I encourage DEQ to prioritize electric vehicles and buses for replacement whenever possible with the other 85% of the settlement funds. Doing so will maximize the local economic impact and the reduction of air pollution.

I encourage you to not use the funding for natural gas, propane or diesel vehicles. Further dependence on fossil fuels means more pollution. Only a transition to electric vehicles and investment in EV infrastructure will put us on the road to a 100% clean transportation sector in North Carolina.

Sincerely,

Jeremy Stubbs
38 Grouse Lane
Jeremy, NC 28712
stubbs1493@msn.com
(513) 255-5371

This message was sent by KnowWho, as a service provider only, on behalf of the individual noted in the sender information.

From: Bob Dietz (bobdietz51@gmail.com) Sent You a Personal Message
To: [daq.NC_VWGrants](#)
Subject: [External] Use Volkswagen funds to electrify NC transportation
Date: Tuesday, December 05, 2017 5:25:03 PM

CAUTION: External email. Do not click links or open attachments unless verified. Send all suspicious email as an attachment to report.spam@nc.gov.

Dear Division of Air Quality,

I am writing to urge DEQ to wisely invest the \$92 million in Volkswagen settlement funds in electric vehicles and infrastructure. Taking advantage of these funds to jumpstart the electrification of North Carolina's transportation sector will mean less money sent out of state for petroleum, more in-state jobs, and cleaner air.

Specifically, I recommend that DEQ allocate the maximum allowable amount (15%) of the funds for electric vehicle charging infrastructure and installations. And I encourage DEQ to prioritize electric vehicles and buses for replacement whenever possible with the other 85% of the settlement funds. Doing so will maximize the local economic impact and the reduction of air pollution.

I encourage you to not use the funding for natural gas, propane or diesel vehicles. Further dependence on fossil fuels means more pollution. Only a transition to electric vehicles and investment in EV infrastructure will put us on the road to a 100% clean transportation sector in North Carolina.

Sincerely,

Bob Dietz
310 Kettlebridge Dr.
Cary, NC 27511
bobdietz51@gmail.com
(919) 387-7675

This message was sent by KnowWho, as a service provider only, on behalf of the individual noted in the sender information.

From: Martha Spencer (spencer_martha@hotmail.com) Sent You a Personal Message
To: [daq.NC_VWGrants](#)
Subject: [External] Use Volkswagen funds to electrify NC transportation
Date: Tuesday, December 05, 2017 5:24:06 PM

CAUTION: External email. Do not click links or open attachments unless verified. Send all suspicious email as an attachment to report.spam@nc.gov.

Dear Division of Air Quality,

I am writing to urge DEQ to wisely invest the \$92 million in Volkswagen settlement funds in electric vehicles and infrastructure. Taking advantage of these funds to jumpstart the electrification of North Carolina's transportation sector will mean less money sent out of state for petroleum, more in-state jobs, and cleaner air.

Specifically, I recommend that DEQ allocate the maximum allowable amount (15%) of the funds for electric vehicle charging infrastructure and installations. And I encourage DEQ to prioritize electric vehicles and buses for replacement whenever possible with the other 85% of the settlement funds. Doing so will maximize the local economic impact and the reduction of air pollution.

I encourage you to not use the funding for natural gas, propane or diesel vehicles. Further dependence on fossil fuels means more pollution. Only a transition to electric vehicles and investment in EV infrastructure will put us on the road to a 100% clean transportation sector in North Carolina.

Sincerely,

Martha Spencer
988 Henry Mountain Road
Brevard, NC 28712
spencer_martha@hotmail.com
(828) 885-2680

This message was sent by KnowWho, as a service provider only, on behalf of the individual noted in the sender information.

From: Robert Martin (kelly.martin47@gmail.com) Sent You a Personal Message
To: [daq.NC_VWGrants](#)
Subject: [External] Use Volkswagen funds to electrify NC transportation
Date: Tuesday, December 05, 2017 5:23:44 PM

CAUTION: External email. Do not click links or open attachments unless verified. Send all suspicious email as an attachment to report.spam@nc.gov.

Dear Division of Air Quality,

I am writing to urge DEQ to wisely invest the \$92 million in Volkswagen settlement funds in electric vehicles and infrastructure. Taking advantage of these funds to jumpstart the electrification of North Carolina's transportation sector will mean less money sent out of state for petroleum, more in-state jobs, and cleaner air.

Specifically, I recommend that DEQ allocate the maximum allowable amount (15%) of the funds for electric vehicle charging infrastructure and installations. And I encourage DEQ to prioritize electric vehicles and buses for replacement whenever possible with the other 85% of the settlement funds. Doing so will maximize the local economic impact and the reduction of air pollution.

I encourage you to not use the funding for natural gas, propane or diesel vehicles. Further dependence on fossil fuels means more pollution. Only a transition to electric vehicles and investment in EV infrastructure will put us on the road to a 100% clean transportation sector in North Carolina.

Sincerely,

Robert Martin
105 Adrian Street
Mount Holly, NC 28120
kelly.martin47@gmail.com
(704) 433-5336

This message was sent by KnowWho, as a service provider only, on behalf of the individual noted in the sender information.

From: Kathy Dowd (kdowd8@gmail.com) Sent You a Personal Message
To: [daq.NC_VWGrants](#)
Subject: [External] Use Volkswagen funds to electrify NC transportation
Date: Tuesday, December 05, 2017 5:23:20 PM

CAUTION: External email. Do not click links or open attachments unless verified. Send all suspicious email as an attachment to report.spam@nc.gov.

Dear Division of Air Quality,

I am writing to urge DEQ to wisely invest the \$92 million in Volkswagen settlement funds in electric vehicles and infrastructure. Taking advantage of these funds to jumpstart the electrification of North Carolina's transportation sector will mean less money sent out of state for petroleum, more in-state jobs, and cleaner air.

Specifically, I recommend that DEQ allocate the maximum allowable amount (15%) of the funds for electric vehicle charging infrastructure and installations. And I encourage DEQ to prioritize electric vehicles and buses for replacement whenever possible with the other 85% of the settlement funds. Doing so will maximize the local economic impact and the reduction of air pollution.

I encourage you to not use the funding for natural gas, propane or diesel vehicles. Further dependence on fossil fuels means more pollution. Only a transition to electric vehicles and investment in EV infrastructure will put us on the road to a 100% clean transportation sector in North Carolina.

Sincerely,

Kathy Dowd
510 Easy St
Pittsboro, NC 27312
kdowd8@gmail.com
(919) 933-7157

This message was sent by KnowWho, as a service provider only, on behalf of the individual noted in the sender information.

From: Jody Smith (kwjody@yahoo.com) Sent You a Personal Message
To: [daq.NC_VWGrants](#)
Subject: [External] Use Volkswagen funds to electrify NC transportation
Date: Tuesday, December 05, 2017 5:23:17 PM

CAUTION: External email. Do not click links or open attachments unless verified. Send all suspicious email as an attachment to report.spam@nc.gov.

Dear Division of Air Quality,

I am writing to urge DEQ to wisely invest the \$92 million in Volkswagen settlement funds in electric vehicles and infrastructure. Taking advantage of these funds to jumpstart the electrification of North Carolina's transportation sector will mean less money sent out of state for petroleum, more in-state jobs, and cleaner air.

Specifically, I recommend that DEQ allocate the maximum allowable amount (15%) of the funds for electric vehicle charging infrastructure and installations. And I encourage DEQ to prioritize electric vehicles and buses for replacement whenever possible with the other 85% of the settlement funds. Doing so will maximize the local economic impact and the reduction of air pollution.

I encourage you to not use the funding for natural gas, propane or diesel vehicles. Further dependence on fossil fuels means more pollution. Only a transition to electric vehicles and investment in EV infrastructure will put us on the road to a 100% clean transportation sector in North Carolina.

Sincerely,

Jody Smith
120 Highland St.
Weaverville, NC 28787
kwjody@yahoo.com
(305) 304-2064

This message was sent by KnowWho, as a service provider only, on behalf of the individual noted in the sender information.

From: Anne Fondren (fodro2@aol.com) Sent You a Personal Message
To: [daq.NC_VWGrants](#)
Subject: [External] Use Volkswagen funds to electrify NC transportation
Date: Tuesday, December 05, 2017 5:22:20 PM

CAUTION: External email. Do not click links or open attachments unless verified. Send all suspicious email as an attachment to report.spam@nc.gov.

Dear Division of Air Quality,

I am writing to urge DEQ to wisely invest the \$92 million in Volkswagen settlement funds in electric vehicles and infrastructure. Taking advantage of these funds to jumpstart the electrification of North Carolina's transportation sector will mean less money sent out of state for petroleum, more in-state jobs, and cleaner air.

Specifically, I recommend that DEQ allocate the maximum allowable amount (15%) of the funds for electric vehicle charging infrastructure and installations. And I encourage DEQ to prioritize electric vehicles and buses for replacement whenever possible with the other 85% of the settlement funds. Doing so will maximize the local economic impact and the reduction of air pollution.

I encourage you to not use the funding for natural gas, propane or diesel vehicles. Further dependence on fossil fuels means more pollution. Only a transition to electric vehicles and investment in EV infrastructure will put us on the road to a 100% clean transportation sector in North Carolina.

Sincerely,

Anne Fondren
818 Sound View Drive
Hampstead, NC 28443
fodro2@aol.com
(910) 352-2229

This message was sent by KnowWho, as a service provider only, on behalf of the individual noted in the sender information.

From: Michael Minnick (michael.minnick+credo@gmail.com) Sent You a Personal Message
To: [daq.NC_VWGrants](#)
Subject: [External] Use Volkswagen funds to electrify NC transportation
Date: Tuesday, December 05, 2017 5:22:18 PM

CAUTION: External email. Do not click links or open attachments unless verified. Send all suspicious email as an attachment to report.spam@nc.gov.

Dear Division of Air Quality,

I am writing to urge DEQ to wisely invest the \$92 million in Volkswagen settlement funds in electric vehicles and infrastructure. Taking advantage of these funds to jumpstart the electrification of North Carolina's transportation sector will mean less money sent out of state for petroleum, more in-state jobs, and cleaner air.

Specifically, I recommend that DEQ allocate the maximum allowable amount (15%) of the funds for electric vehicle charging infrastructure and installations. And I encourage DEQ to prioritize electric vehicles and buses for replacement whenever possible with the other 85% of the settlement funds. Doing so will maximize the local economic impact and the reduction of air pollution.

I encourage you to not use the funding for natural gas, propane or diesel vehicles. Further dependence on fossil fuels means more pollution. Only a transition to electric vehicles and investment in EV infrastructure will put us on the road to a 100% clean transportation sector in North Carolina.

Sincerely,

Michael Minnick
2951 Cosmo Dr
Fayetteville, NC 28304
michael.minnick+credo@gmail.com
(910) 494-5877

This message was sent by KnowWho, as a service provider only, on behalf of the individual noted in the sender information.

From: Brandylyn Lemen (brandylyn.lemen@gmail.com) Sent You a Personal Message
To: [daq.NC_VWGrants](#)
Subject: [External] Use Volkswagen funds to electrify NC transportation
Date: Tuesday, December 05, 2017 5:17:28 PM

CAUTION: External email. Do not click links or open attachments unless verified. Send all suspicious email as an attachment to report.spam@nc.gov.

Dear Division of Air Quality,

I am writing to urge DEQ to wisely invest the \$92 million in Volkswagen settlement funds in electric vehicles and infrastructure. Taking advantage of these funds to jumpstart the electrification of North Carolina's transportation sector will mean less money sent out of state for petroleum, more in-state jobs, and cleaner air.

Specifically, I recommend that DEQ allocate the maximum allowable amount (15%) of the funds for electric vehicle charging infrastructure and installations. And I encourage DEQ to prioritize electric vehicles and buses for replacement whenever possible with the other 85% of the settlement funds. Doing so will maximize the local economic impact and the reduction of air pollution.

I encourage you to not use the funding for natural gas, propane or diesel vehicles. Further dependence on fossil fuels means more pollution. Only a transition to electric vehicles and investment in EV infrastructure will put us on the road to a 100% clean transportation sector in North Carolina.

Sincerely,

Brandylyn Lemen
2 Twinleaf Pl
Durham, NC 27705
brandylyn.lemen@gmail.com
(919) 555-1212

This message was sent by KnowWho, as a service provider only, on behalf of the individual noted in the sender information.

From: Marla Drucker (marla.drucker55@gmail.com) Sent You a Personal Message
To: [daq.NC_VWGrants](#)
Subject: [External] Use Volkswagen funds to electrify NC transportation
Date: Tuesday, December 05, 2017 5:17:27 PM

CAUTION: External email. Do not click links or open attachments unless verified. Send all suspicious email as an attachment to report.spam@nc.gov.

Dear Division of Air Quality,

I am writing to urge DEQ to wisely invest the \$92 million in Volkswagen settlement funds in electric vehicles and infrastructure. Taking advantage of these funds to jumpstart the electrification of North Carolina's transportation sector will mean less money sent out of state for petroleum, more in-state jobs, and cleaner air.

Specifically, I recommend that DEQ allocate the maximum allowable amount (15%) of the funds for electric vehicle charging infrastructure and installations. And I encourage DEQ to prioritize electric vehicles and buses for replacement whenever possible with the other 85% of the settlement funds. Doing so will maximize the local economic impact and the reduction of air pollution.

I encourage you to not use the funding for natural gas, propane or diesel vehicles. Further dependence on fossil fuels means more pollution. Only a transition to electric vehicles and investment in EV infrastructure will put us on the road to a 100% clean transportation sector in North Carolina.

Sincerely,

Marla Drucker
4509 Parkgate Dr
Marla, NC 28105
marla.drucker55@gmail.com
(980) 245-8414

This message was sent by KnowWho, as a service provider only, on behalf of the individual noted in the sender information.

From: Stacy DeCaussin (taiseisola@aol.com) Sent You a Personal Message
To: [daq.NC_VWGrants](#)
Subject: [External] Use Volkswagen funds to electrify NC transportation
Date: Tuesday, December 05, 2017 5:16:17 PM

CAUTION: External email. Do not click links or open attachments unless verified. Send all suspicious email as an attachment to report.spam@nc.gov.

Dear Division of Air Quality,

I am writing to urge DEQ to wisely invest the \$92 million in Volkswagen settlement funds in electric vehicles and infrastructure. Taking advantage of these funds to jumpstart the electrification of North Carolina's transportation sector will mean less money sent out of state for petroleum, more in-state jobs, and cleaner air.

Specifically, I recommend that DEQ allocate the maximum allowable amount (15%) of the funds for electric vehicle charging infrastructure and installations. And I encourage DEQ to prioritize electric vehicles and buses for replacement whenever possible with the other 85% of the settlement funds. Doing so will maximize the local economic impact and the reduction of air pollution.

I encourage you to not use the funding for natural gas, propane or diesel vehicles. Further dependence on fossil fuels means more pollution. Only a transition to electric vehicles and investment in EV infrastructure will put us on the road to a 100% clean transportation sector in North Carolina.

Sincerely,

Stacy DeCaussin
1715 White Road
Wilmington, NC 28405
taiseisola@aol.com
(910) 619-6667

This message was sent by KnowWho, as a service provider only, on behalf of the individual noted in the sender information.

From: Shawna Hanson (ewhanson12@gmail.com) Sent You a Personal Message
To: daq.NC_VWGrants
Subject: [External] Use Volkswagen funds to electrify NC transportation
Date: Tuesday, December 05, 2017 5:15:51 PM

CAUTION: External email. Do not click links or open attachments unless verified. Send all suspicious email as an attachment to report.spam@nc.gov.

Dear Division of Air Quality,

I am writing to urge DEQ to wisely invest the \$92 million in Volkswagen settlement funds in electric vehicles and infrastructure. Taking advantage of these funds to jumpstart the electrification of North Carolina's transportation sector will mean less money sent out of state for petroleum, more in-state jobs, and cleaner air.

Specifically, I recommend that DEQ allocate the maximum allowable amount (15%) of the funds for electric vehicle charging infrastructure and installations. And I encourage DEQ to prioritize electric vehicles and buses for replacement whenever possible with the other 85% of the settlement funds. Doing so will maximize the local economic impact and the reduction of air pollution.

I encourage you to not use the funding for natural gas, propane or diesel vehicles. Further dependence on fossil fuels means more pollution. Only a transition to electric vehicles and investment in EV infrastructure will put us on the road to a 100% clean transportation sector in North Carolina.

Sincerely,

Shawna Hanson
84 Saint Dunstons Road
Asheville, NC 28803
ewhanson12@gmail.com
(828) 850-5706

This message was sent by KnowWho, as a service provider only, on behalf of the individual noted in the sender information.

From: Dominic Cervantes (aeonofdoom@hotmail.com) Sent You a Personal Message
To: [daq.NC_VWGrants](#)
Subject: [External] Use Volkswagen funds to electrify NC transportation
Date: Tuesday, December 05, 2017 5:14:57 PM

CAUTION: External email. Do not click links or open attachments unless verified. Send all suspicious email as an attachment to report.spam@nc.gov.

Dear Division of Air Quality,

I am writing to urge DEQ to wisely invest the \$92 million in Volkswagen settlement funds in electric vehicles and infrastructure. Taking advantage of these funds to jumpstart the electrification of North Carolina's transportation sector will mean less money sent out of state for petroleum, more in-state jobs, and cleaner air.

Specifically, I recommend that DEQ allocate the maximum allowable amount (15%) of the funds for electric vehicle charging infrastructure and installations. And I encourage DEQ to prioritize electric vehicles and buses for replacement whenever possible with the other 85% of the settlement funds. Doing so will maximize the local economic impact and the reduction of air pollution.

I encourage you to not use the funding for natural gas, propane or diesel vehicles. Further dependence on fossil fuels means more pollution. Only a transition to electric vehicles and investment in EV infrastructure will put us on the road to a 100% clean transportation sector in North Carolina.

Sincerely,

Dominic Cervantes
620 Azalea Ave
Black Mountain, NC 28711
aeonofdoom@hotmail.com
(831) 419-3485

This message was sent by KnowWho, as a service provider only, on behalf of the individual noted in the sender information.

From: Brian Coletta (bcoletta2@yahoo.com) Sent You a Personal Message
To: [daq.NC_VWGrants](#)
Subject: [External] Use Volkswagen funds to electrify NC transportation
Date: Tuesday, December 05, 2017 5:13:46 PM

CAUTION: External email. Do not click links or open attachments unless verified. Send all suspicious email as an attachment to report.spam@nc.gov.

Dear Division of Air Quality,

I am writing to urge DEQ to wisely invest the \$92 million in Volkswagen settlement funds in electric vehicles and infrastructure. Taking advantage of these funds to jumpstart the electrification of North Carolina's transportation sector will mean less money sent out of state for petroleum, more in-state jobs, and cleaner air.

Specifically, I recommend that DEQ allocate the maximum allowable amount (15%) of the funds for electric vehicle charging infrastructure and installations. And I encourage DEQ to prioritize electric vehicles and buses for replacement whenever possible with the other 85% of the settlement funds. Doing so will maximize the local economic impact and the reduction of air pollution.

I encourage you to not use the funding for natural gas, propane or diesel vehicles. Further dependence on fossil fuels means more pollution. Only a transition to electric vehicles and investment in EV infrastructure will put us on the road to a 100% clean transportation sector in North Carolina.

Sincerely,

Brian Coletta
1209 Cliffspring Ct.
Winston Salem, NC 27104
bcoletta2@yahoo.com
(336) 682-5638

This message was sent by KnowWho, as a service provider only, on behalf of the individual noted in the sender information.

From: Joanne Heckel (jch52969@aol.com) Sent You a Personal Message
To: [daq.NC_VWGrants](#)
Subject: [External] Use Volkswagen funds to electrify NC transportation
Date: Tuesday, December 05, 2017 5:13:46 PM

CAUTION: External email. Do not click links or open attachments unless verified. Send all suspicious email as an attachment to report.spam@nc.gov.

Dear Division of Air Quality,

I am writing to urge DEQ to wisely invest the \$92 million in Volkswagen settlement funds in electric vehicles and infrastructure. Taking advantage of these funds to jumpstart the electrification of North Carolina's transportation sector will mean less money sent out of state for petroleum, more in-state jobs, and cleaner air.

Specifically, I recommend that DEQ allocate the maximum allowable amount (15%) of the funds for electric vehicle charging infrastructure and installations. And I encourage DEQ to prioritize electric vehicles and buses for replacement whenever possible with the other 85% of the settlement funds. Doing so will maximize the local economic impact and the reduction of air pollution.

I encourage you to not use the funding for natural gas, propane or diesel vehicles. Further dependence on fossil fuels means more pollution. Only a transition to electric vehicles and investment in EV infrastructure will put us on the road to a 100% clean transportation sector in North Carolina.

Sincerely,

Joanne Heckel
115 Sir Patrick's Ct
Clemmons, NC 27012
jch52969@aol.com
(336) 766-8465

This message was sent by KnowWho, as a service provider only, on behalf of the individual noted in the sender information.

From: Nathan Peterson (fhmsnathan@yahoo.com) Sent You a Personal Message
To: [daq.NC_VWGrants](#)
Subject: [External] Use Volkswagen funds to electrify NC transportation
Date: Tuesday, December 05, 2017 5:12:55 PM

CAUTION: External email. Do not click links or open attachments unless verified. Send all suspicious email as an attachment to report.spam@nc.gov.

Dear Division of Air Quality,

I am writing to urge DEQ to wisely invest the \$92 million in Volkswagen settlement funds in electric vehicles and infrastructure. Taking advantage of these funds to jumpstart the electrification of North Carolina's transportation sector will mean less money sent out of state for petroleum, more in-state jobs, and cleaner air.

Specifically, I recommend that DEQ allocate the maximum allowable amount (15%) of the funds for electric vehicle charging infrastructure and installations. And I encourage DEQ to prioritize electric vehicles and buses for replacement whenever possible with the other 85% of the settlement funds. Doing so will maximize the local economic impact and the reduction of air pollution.

I encourage you to not use the funding for natural gas, propane or diesel vehicles. Further dependence on fossil fuels means more pollution. Only a transition to electric vehicles and investment in EV infrastructure will put us on the road to a 100% clean transportation sector in North Carolina.

Sincerely,

Nathan Peterson
211 Pearson St
Wilson, NC 27893
fhmsnathan@yahoo.com
(252) 373-3136

This message was sent by KnowWho, as a service provider only, on behalf of the individual noted in the sender information.

From: Lynne Berryhill (lawb818@gmail.com) Sent You a Personal Message
To: [daq.NC_VWGrants](#)
Subject: [External] Use Volkswagen funds to electrify NC transportation
Date: Tuesday, December 05, 2017 5:11:38 PM

CAUTION: External email. Do not click links or open attachments unless verified. Send all suspicious email as an attachment to report.spam@nc.gov.

Dear Division of Air Quality,

I am writing to urge DEQ to wisely invest the \$92 million in Volkswagen settlement funds in electric vehicles and infrastructure. Taking advantage of these funds to jumpstart the electrification of North Carolina's transportation sector will mean less money sent out of state for petroleum, more in-state jobs, and cleaner air.

Specifically, I recommend that DEQ allocate the maximum allowable amount (15%) of the funds for electric vehicle charging infrastructure and installations. And I encourage DEQ to prioritize electric vehicles and buses for replacement whenever possible with the other 85% of the settlement funds. Doing so will maximize the local economic impact and the reduction of air pollution.

I encourage you to not use the funding for natural gas, propane or diesel vehicles. Further dependence on fossil fuels means more pollution. Only a transition to electric vehicles and investment in EV infrastructure will put us on the road to a 100% clean transportation sector in North Carolina.

Sincerely,

Lynne Berryhill
311 Leftwich Street
Lynne, NC 27405
lawb818@gmail.com
(336) 317-1636

This message was sent by KnowWho, as a service provider only, on behalf of the individual noted in the sender information.

From: Lynn Elliott (craper@nc.rr.com) Sent You a Personal Message
To: [daq.NC_VWGrants](#)
Subject: [External] Use Volkswagen funds to electrify NC transportation
Date: Tuesday, December 05, 2017 5:11:13 PM

CAUTION: External email. Do not click links or open attachments unless verified. Send all suspicious email as an attachment to report.spam@nc.gov.

Dear Division of Air Quality,

I am writing to urge DEQ to wisely invest the \$92 million in Volkswagen settlement funds in electric vehicles and infrastructure. Taking advantage of these funds to jumpstart the electrification of North Carolina's transportation sector will mean less money sent out of state for petroleum, more in-state jobs, and cleaner air.

Specifically, I recommend that DEQ allocate the maximum allowable amount (15%) of the funds for electric vehicle charging infrastructure and installations. And I encourage DEQ to prioritize electric vehicles and buses for replacement whenever possible with the other 85% of the settlement funds. Doing so will maximize the local economic impact and the reduction of air pollution.

I encourage you to not use the funding for natural gas, propane or diesel vehicles. Further dependence on fossil fuels means more pollution. Only a transition to electric vehicles and investment in EV infrastructure will put us on the road to a 100% clean transportation sector in North Carolina.

Sincerely,

Lynn Elliott
2614 Woodmont Dr
Durham, NC 27705
craper@nc.rr.com
(919) 698-3282

This message was sent by KnowWho, as a service provider only, on behalf of the individual noted in the sender information.

From: Frank McConnell (mistamac2@gmail.com) Sent You a Personal Message
To: [daq.NC_VWGrants](#)
Subject: [External] Use Volkswagen funds to electrify NC transportation
Date: Tuesday, December 05, 2017 5:10:46 PM

CAUTION: External email. Do not click links or open attachments unless verified. Send all suspicious email as an attachment to report.spam@nc.gov.

Dear Division of Air Quality,

I am writing to urge DEQ to wisely invest the \$92 million in Volkswagen settlement funds in electric vehicles and infrastructure. Taking advantage of these funds to jumpstart the electrification of North Carolina's transportation sector will mean less money sent out of state for petroleum, more in-state jobs, and cleaner air.

Specifically, I recommend that DEQ allocate the maximum allowable amount (15%) of the funds for electric vehicle charging infrastructure and installations. And I encourage DEQ to prioritize electric vehicles and buses for replacement whenever possible with the other 85% of the settlement funds. Doing so will maximize the local economic impact and the reduction of air pollution.

I encourage you to not use the funding for natural gas, propane or diesel vehicles. Further dependence on fossil fuels means more pollution. Only a transition to electric vehicles and investment in EV infrastructure will put us on the road to a 100% clean transportation sector in North Carolina.

Sincerely,

Frank McConnell
763 Cascade Lake Rd.
Pisgah Forest, NC 28768
mistamac2@gmail.com
(828) 885-2289

This message was sent by KnowWho, as a service provider only, on behalf of the individual noted in the sender information.

From: Bryson Palmer (bassbryson35@gmail.com) Sent You a Personal Message
To: [daq.NC_VWGrants](#)
Subject: [External] Use Volkswagen funds to electrify NC transportation
Date: Tuesday, December 05, 2017 5:10:19 PM

CAUTION: External email. Do not click links or open attachments unless verified. Send all suspicious email as an attachment to report.spam@nc.gov.

Dear Division of Air Quality,

I am writing to urge DEQ to wisely invest the \$92 million in Volkswagen settlement funds in electric vehicles and infrastructure. Taking advantage of these funds to jumpstart the electrification of North Carolina's transportation sector will mean less money sent out of state for petroleum, more in-state jobs, and cleaner air.

Specifically, I recommend that DEQ allocate the maximum allowable amount (15%) of the funds for electric vehicle charging infrastructure and installations. And I encourage DEQ to prioritize electric vehicles and buses for replacement whenever possible with the other 85% of the settlement funds. Doing so will maximize the local economic impact and the reduction of air pollution.

I encourage you to not use the funding for natural gas, propane or diesel vehicles. Further dependence on fossil fuels means more pollution. Only a transition to electric vehicles and investment in EV infrastructure will put us on the road to a 100% clean transportation sector in North Carolina.

Sincerely,

Bryson Palmer
7 Debbie View Dr, Barn Apartment
swannanoa, NC 28778
bassbryson35@gmail.com
(662) 255-9298

This message was sent by KnowWho, as a service provider only, on behalf of the individual noted in the sender information.

From: Pamela Corbett (pamcorbett@aol.com) Sent You a Personal Message
To: [daq.NC_VWGrants](#)
Subject: [External] Use Volkswagen funds to electrify NC transportation
Date: Tuesday, December 05, 2017 5:08:57 PM

CAUTION: External email. Do not click links or open attachments unless verified. Send all suspicious email as an attachment to report.spam@nc.gov.

Dear Division of Air Quality,

I am writing to urge DEQ to wisely invest the \$92 million in Volkswagen settlement funds in electric vehicles and infrastructure. Taking advantage of these funds to jumpstart the electrification of North Carolina's transportation sector will mean less money sent out of state for petroleum, more in-state jobs, and cleaner air.

Specifically, I recommend that DEQ allocate the maximum allowable amount (15%) of the funds for electric vehicle charging infrastructure and installations. And I encourage DEQ to prioritize electric vehicles and buses for replacement whenever possible with the other 85% of the settlement funds. Doing so will maximize the local economic impact and the reduction of air pollution.

I encourage you to not use the funding for natural gas, propane or diesel vehicles. Further dependence on fossil fuels means more pollution. Only a transition to electric vehicles and investment in EV infrastructure will put us on the road to a 100% clean transportation sector in North Carolina.

Sincerely,

Pamela Corbett
3560 buena vista rd
winston salem, NC 27106
pamcorbett@aol.com
(336) 761-1121

This message was sent by KnowWho, as a service provider only, on behalf of the individual noted in the sender information.

From: Paul Brown (revpaulvet@gmail.com) Sent You a Personal Message
To: [daq.NC_VWGrants](#)
Subject: [External] Use Volkswagen funds to electrify NC transportation
Date: Tuesday, December 05, 2017 5:08:34 PM

CAUTION: External email. Do not click links or open attachments unless verified. Send all suspicious email as an attachment to report.spam@nc.gov.

Dear Division of Air Quality,

I am writing to urge DEQ to wisely invest the \$92 million in Volkswagen settlement funds in electric vehicles and infrastructure. Taking advantage of these funds to jumpstart the electrification of North Carolina's transportation sector will mean less money sent out of state for petroleum, more in-state jobs, and cleaner air.

Specifically, I recommend that DEQ allocate the maximum allowable amount (15%) of the funds for electric vehicle charging infrastructure and installations. And I encourage DEQ to prioritize electric vehicles and buses for replacement whenever possible with the other 85% of the settlement funds. Doing so will maximize the local economic impact and the reduction of air pollution.

I encourage you to not use the funding for natural gas, propane or diesel vehicles. Further dependence on fossil fuels means more pollution. Only a transition to electric vehicles and investment in EV infrastructure will put us on the road to a 100% clean transportation sector in North Carolina.

Sincerely,

Paul Brown
117 Seneca Road
Murphy, NC 28906
revpaulvet@gmail.com
(828) 557-5720

This message was sent by KnowWho, as a service provider only, on behalf of the individual noted in the sender information.

From: Josie Purbrick (josiebp@gmail.com) Sent You a Personal Message
To: [daq.NC_VWGrants](#)
Subject: [External] Use Volkswagen funds to electrify NC transportation
Date: Tuesday, December 05, 2017 5:08:06 PM

CAUTION: External email. Do not click links or open attachments unless verified. Send all suspicious email as an attachment to report.spam@nc.gov.

Dear Division of Air Quality,

I am writing to urge DEQ to wisely invest the \$92 million in Volkswagen settlement funds in electric vehicles and infrastructure. Taking advantage of these funds to jumpstart the electrification of North Carolina's transportation sector will mean less money sent out of state for petroleum, more in-state jobs, and cleaner air.

Specifically, I recommend that DEQ allocate the maximum allowable amount (15%) of the funds for electric vehicle charging infrastructure and installations. And I encourage DEQ to prioritize electric vehicles and buses for replacement whenever possible with the other 85% of the settlement funds. Doing so will maximize the local economic impact and the reduction of air pollution.

I encourage you to not use the funding for natural gas, propane or diesel vehicles. Further dependence on fossil fuels means more pollution. Only a transition to electric vehicles and investment in EV infrastructure will put us on the road to a 100% clean transportation sector in North Carolina.

Sincerely,

Josie Purbrick
171 swannanoa ave
Asheville, NC 28806
josiebp@gmail.com
(504) 301-8993

This message was sent by KnowWho, as a service provider only, on behalf of the individual noted in the sender information.

From: Connie Raper (ckrmob@nc.rr.com) Sent You a Personal Message
To: [daq.NC_VWGrants](#)
Subject: [External] Use Volkswagen funds to electrify NC transportation
Date: Tuesday, December 05, 2017 5:07:47 PM

CAUTION: External email. Do not click links or open attachments unless verified. Send all suspicious email as an attachment to report.spam@nc.gov.

Dear Division of Air Quality,

I am writing to urge DEQ to wisely invest the \$92 million in Volkswagen settlement funds in electric vehicles and infrastructure. Taking advantage of these funds to jumpstart the electrification of North Carolina's transportation sector will mean less money sent out of state for petroleum, more in-state jobs, and cleaner air.

Specifically, I recommend that DEQ allocate the maximum allowable amount (15%) of the funds for electric vehicle charging infrastructure and installations. And I encourage DEQ to prioritize electric vehicles and buses for replacement whenever possible with the other 85% of the settlement funds. Doing so will maximize the local economic impact and the reduction of air pollution.

I encourage you to not use the funding for natural gas, propane or diesel vehicles. Further dependence on fossil fuels means more pollution. Only a transition to electric vehicles and investment in EV infrastructure will put us on the road to a 100% clean transportation sector in North Carolina.

Sincerely,

Connie Raper
2614 Woodmont Dr
Durham, NC 27705
ckrmob@nc.rr.com
(919) 698-3282

This message was sent by KnowWho, as a service provider only, on behalf of the individual noted in the sender information.

From: Peter Murphy (pmurphyc@yahoo.com) Sent You a Personal Message
To: [daq.NC_VWGrants](#)
Subject: [External] Use Volkswagen funds to electrify NC transportation
Date: Tuesday, December 05, 2017 5:07:47 PM

CAUTION: External email. Do not click links or open attachments unless verified. Send all suspicious email as an attachment to report.spam@nc.gov.

Dear Division of Air Quality,

I am writing to urge DEQ to wisely invest the \$92 million in Volkswagen settlement funds in electric vehicles and infrastructure. Taking advantage of these funds to jumpstart the electrification of North Carolina's transportation sector will mean less money sent out of state for petroleum, more in-state jobs, and cleaner air.

Specifically, I recommend that DEQ allocate the maximum allowable amount (15%) of the funds for electric vehicle charging infrastructure and installations. And I encourage DEQ to prioritize electric vehicles and buses for replacement whenever possible with the other 85% of the settlement funds. Doing so will maximize the local economic impact and the reduction of air pollution.

I encourage you to not use the funding for natural gas, propane or diesel vehicles. Further dependence on fossil fuels means more pollution. Only a transition to electric vehicles and investment in EV infrastructure will put us on the road to a 100% clean transportation sector in North Carolina.

Sincerely,

Peter Murphy
3610 Baron Monck Pass
Raleigh, NC 27612
pmurphyc@yahoo.com
(919) 561-3758

This message was sent by KnowWho, as a service provider only, on behalf of the individual noted in the sender information.

From: Don Peeples (don.peeples@verizon.net) Sent You a Personal Message
To: [daq.NC_VWGrants](#)
Subject: [External] Use Volkswagen funds to electrify NC transportation
Date: Tuesday, December 05, 2017 5:06:55 PM

CAUTION: External email. Do not click links or open attachments unless verified. Send all suspicious email as an attachment to report.spam@nc.gov.

Dear Division of Air Quality,

I am writing to urge DEQ to wisely invest the \$92 million in Volkswagen settlement funds in electric vehicles and infrastructure. Taking advantage of these funds to jumpstart the electrification of North Carolina's transportation sector will mean less money sent out of state for petroleum, more in-state jobs, and cleaner air.

Specifically, I recommend that DEQ allocate the maximum allowable amount (15%) of the funds for electric vehicle charging infrastructure and installations. And I encourage DEQ to prioritize electric vehicles and buses for replacement whenever possible with the other 85% of the settlement funds. Doing so will maximize the local economic impact and the reduction of air pollution.

I encourage you to not use the funding for natural gas, propane or diesel vehicles. Further dependence on fossil fuels means more pollution. Only a transition to electric vehicles and investment in EV infrastructure will put us on the road to a 100% clean transportation sector in North Carolina.

Sincerely,

Don Peeples
341 Yorkshire Drive
Sylva, NC 28779
don.peeples@verizon.net
(410) 207-1340

This message was sent by KnowWho, as a service provider only, on behalf of the individual noted in the sender information.

From: Tom Shafer (tom.shafer@live.com) Sent You a Personal Message
To: [daq.NC_VWGrants](#)
Subject: [External] Use Volkswagen funds to electrify NC transportation
Date: Tuesday, December 05, 2017 5:06:36 PM

CAUTION: External email. Do not click links or open attachments unless verified. Send all suspicious email as an attachment to report.spam@nc.gov.

Dear Division of Air Quality,

I am writing to urge DEQ to wisely invest the \$92 million in Volkswagen settlement funds in electric vehicles and infrastructure. Taking advantage of these funds to jumpstart the electrification of North Carolina's transportation sector will mean less money sent out of state for petroleum, more in-state jobs, and cleaner air.

Specifically, I recommend that DEQ allocate the maximum allowable amount (15%) of the funds for electric vehicle charging infrastructure and installations. And I encourage DEQ to prioritize electric vehicles and buses for replacement whenever possible with the other 85% of the settlement funds. Doing so will maximize the local economic impact and the reduction of air pollution.

I encourage you to not use the funding for natural gas, propane or diesel vehicles. Further dependence on fossil fuels means more pollution. Only a transition to electric vehicles and investment in EV infrastructure will put us on the road to a 100% clean transportation sector in North Carolina.

Sincerely,

Tom Shafer
158 Estelle Park Dr
Asheville, NC 28806
tom.shafer@live.com
(740) 817-1490

This message was sent by KnowWho, as a service provider only, on behalf of the individual noted in the sender information.

From: Michael Busko (mvbusko@gmail.com) Sent You a Personal Message
To: [daq.NC_VWGrants](#)
Subject: [External] Use Volkswagen funds to electrify NC transportation
Date: Tuesday, December 05, 2017 5:06:35 PM

CAUTION: External email. Do not click links or open attachments unless verified. Send all suspicious email as an attachment to report.spam@nc.gov.

Dear Division of Air Quality,

I am writing to urge DEQ to wisely invest the \$92 million in Volkswagen settlement funds in electric vehicles and infrastructure. Taking advantage of these funds to jumpstart the electrification of North Carolina's transportation sector will mean less money sent out of state for petroleum, more in-state jobs, and cleaner air.

Specifically, I recommend that DEQ allocate the maximum allowable amount (15%) of the funds for electric vehicle charging infrastructure and installations. And I encourage DEQ to prioritize electric vehicles and buses for replacement whenever possible with the other 85% of the settlement funds. Doing so will maximize the local economic impact and the reduction of air pollution.

I encourage you to not use the funding for natural gas, propane or diesel vehicles. Further dependence on fossil fuels means more pollution. Only a transition to electric vehicles and investment in EV infrastructure will put us on the road to a 100% clean transportation sector in North Carolina.

Sincerely,

Michael Busko
30 Whitehaven Dr
Pinehurst, NC 28374
mvbusko@gmail.com
(919) 943-9381

This message was sent by KnowWho, as a service provider only, on behalf of the individual noted in the sender information.

From: Denise Lafone (deniselafone@hotmail.com) Sent You a Personal Message
To: [daq.NC_VWGrants](#)
Subject: [External] Use Volkswagen funds to electrify NC transportation
Date: Tuesday, December 05, 2017 5:05:36 PM

CAUTION: External email. Do not click links or open attachments unless verified. Send all suspicious email as an attachment to report.spam@nc.gov.

Dear Division of Air Quality,

I am writing to urge DEQ to wisely invest the \$92 million in Volkswagen settlement funds in electric vehicles and infrastructure. Taking advantage of these funds to jumpstart the electrification of North Carolina's transportation sector will mean less money sent out of state for petroleum, more in-state jobs, and cleaner air.

Specifically, I recommend that DEQ allocate the maximum allowable amount (15%) of the funds for electric vehicle charging infrastructure and installations. And I encourage DEQ to prioritize electric vehicles and buses for replacement whenever possible with the other 85% of the settlement funds. Doing so will maximize the local economic impact and the reduction of air pollution.

I encourage you to not use the funding for natural gas, propane or diesel vehicles. Further dependence on fossil fuels means more pollution. Only a transition to electric vehicles and investment in EV infrastructure will put us on the road to a 100% clean transportation sector in North Carolina.

Sincerely,

Denise Lafone
253 PGW Drive, #101
Elkin, NC 28621
deniselafone@hotmail.com
(714) 914-7802

This message was sent by KnowWho, as a service provider only, on behalf of the individual noted in the sender information.

From: Win Southworth (southworth@hotmail.com) Sent You a Personal Message
To: daq.NC_VWGrants
Subject: [External] Use Volkswagen funds to electrify NC transportation
Date: Tuesday, December 05, 2017 5:05:08 PM

CAUTION: External email. Do not click links or open attachments unless verified. Send all suspicious email as an attachment to report.spam@nc.gov.

Dear Division of Air Quality,

I am writing to urge DEQ to wisely invest the \$92 million in Volkswagen settlement funds in electric vehicles and infrastructure. Taking advantage of these funds to jumpstart the electrification of North Carolina's transportation sector will mean less money sent out of state for petroleum, more in-state jobs, and cleaner air.

Specifically, I recommend that DEQ allocate the maximum allowable amount (15%) of the funds for electric vehicle charging infrastructure and installations. And I encourage DEQ to prioritize electric vehicles and buses for replacement whenever possible with the other 85% of the settlement funds. Doing so will maximize the local economic impact and the reduction of air pollution.

I encourage you to not use the funding for natural gas, propane or diesel vehicles. Further dependence on fossil fuels means more pollution. Only a transition to electric vehicles and investment in EV infrastructure will put us on the road to a 100% clean transportation sector in North Carolina.

Sincerely,

Win Southworth
701 Warren Wilson Rd.
Swannanoa, NC 28778
southworth@hotmail.com
(828) 989-2993

This message was sent by KnowWho, as a service provider only, on behalf of the individual noted in the sender information.

From: James Zizzo (jzizzo@ec.rr.com) Sent You a Personal Message
To: [daq.NC_VWGrants](#)
Subject: [External] Use Volkswagen funds to electrify NC transportation
Date: Tuesday, December 05, 2017 5:05:02 PM

CAUTION: External email. Do not click links or open attachments unless verified. Send all suspicious email as an attachment to report.spam@nc.gov.

Dear Division of Air Quality,

I am writing to urge DEQ to wisely invest the \$92 million in Volkswagen settlement funds in electric vehicles and infrastructure. Taking advantage of these funds to jumpstart the electrification of North Carolina's transportation sector will mean less money sent out of state for petroleum, more in-state jobs, and cleaner air.

Specifically, I recommend that DEQ allocate the maximum allowable amount (15%) of the funds for electric vehicle charging infrastructure and installations. And I encourage DEQ to prioritize electric vehicles and buses for replacement whenever possible with the other 85% of the settlement funds. Doing so will maximize the local economic impact and the reduction of air pollution.

I encourage you to not use the funding for natural gas, propane or diesel vehicles. Further dependence on fossil fuels means more pollution. Only a transition to electric vehicles and investment in EV infrastructure will put us on the road to a 100% clean transportation sector in North Carolina.

Sincerely,

James Zizzo
2304 Wrightsville Ave. #106
Wilmington, NC 28403
jzizzo@ec.rr.com
(910) 762-6218

This message was sent by KnowWho, as a service provider only, on behalf of the individual noted in the sender information.

From: Merle Love (jimelove@hotmail.com) Sent You a Personal Message
To: [daq.NC_VWGrants](#)
Subject: [External] Use Volkswagen funds to electrify NC transportation
Date: Tuesday, December 05, 2017 5:03:31 PM

CAUTION: External email. Do not click links or open attachments unless verified. Send all suspicious email as an attachment to report.spam@nc.gov.

Dear Division of Air Quality,

I am writing to urge DEQ to wisely invest the \$92 million in Volkswagen settlement funds in electric vehicles and infrastructure. Taking advantage of these funds to jumpstart the electrification of North Carolina's transportation sector will mean less money sent out of state for petroleum, more in-state jobs, and cleaner air.

Specifically, I recommend that DEQ allocate the maximum allowable amount (15%) of the funds for electric vehicle charging infrastructure and installations. And I encourage DEQ to prioritize electric vehicles and buses for replacement whenever possible with the other 85% of the settlement funds. Doing so will maximize the local economic impact and the reduction of air pollution.

I encourage you to not use the funding for natural gas, propane or diesel vehicles. Further dependence on fossil fuels means more pollution. Only a transition to electric vehicles and investment in EV infrastructure will put us on the road to a 100% clean transportation sector in North Carolina.

Sincerely,

Merle Love
198 Governors View Road
Asheville, NC 28805
jimelove@hotmail.com
(828) 505-3435

This message was sent by KnowWho, as a service provider only, on behalf of the individual noted in the sender information.

From: Tammy Dickens (tamkatt2@aol.com) Sent You a Personal Message
To: [daq.NC_VWGrants](#)
Subject: [External] Use Volkswagen funds to electrify NC transportation
Date: Tuesday, December 05, 2017 5:02:45 PM

CAUTION: External email. Do not click links or open attachments unless verified. Send all suspicious email as an attachment to report.spam@nc.gov.

Dear Division of Air Quality,

I am writing to urge DEQ to wisely invest the \$92 million in Volkswagen settlement funds in electric vehicles and infrastructure. Taking advantage of these funds to jumpstart the electrification of North Carolina's transportation sector will mean less money sent out of state for petroleum, more in-state jobs, and cleaner air.

Specifically, I recommend that DEQ allocate the maximum allowable amount (15%) of the funds for electric vehicle charging infrastructure and installations. And I encourage DEQ to prioritize electric vehicles and buses for replacement whenever possible with the other 85% of the settlement funds. Doing so will maximize the local economic impact and the reduction of air pollution.

I encourage you to not use the funding for natural gas, propane or diesel vehicles. Further dependence on fossil fuels means more pollution. Only a transition to electric vehicles and investment in EV infrastructure will put us on the road to a 100% clean transportation sector in North Carolina.

Sincerely,

Tammy Dickens
4214 Guess Rd
Durham, NC 27712
tamkatt2@aol.com
(919) 638-9081

This message was sent by KnowWho, as a service provider only, on behalf of the individual noted in the sender information.

From: BF Beasley (jrsilverfox@hotmail.com) Sent You a Personal Message
To: [daq.NC_VWGrants](#)
Subject: [External] Use Volkswagen funds to electrify NC transportation
Date: Tuesday, December 05, 2017 5:02:39 PM

CAUTION: External email. Do not click links or open attachments unless verified. Send all suspicious email as an attachment to report.spam@nc.gov.

Dear Division of Air Quality,

I am writing to urge DEQ to wisely invest the \$92 million in Volkswagen settlement funds in electric vehicles and infrastructure. Taking advantage of these funds to jumpstart the electrification of North Carolina's transportation sector will mean less money sent out of state for petroleum, more in-state jobs, and cleaner air.

Specifically, I recommend that DEQ allocate the maximum allowable amount (15%) of the funds for electric vehicle charging infrastructure and installations. And I encourage DEQ to prioritize electric vehicles and buses for replacement whenever possible with the other 85% of the settlement funds. Doing so will maximize the local economic impact and the reduction of air pollution.

I encourage you to not use the funding for natural gas, propane or diesel vehicles. Further dependence on fossil fuels means more pollution. Only a transition to electric vehicles and investment in EV infrastructure will put us on the road to a 100% clean transportation sector in North Carolina.

Sincerely,

BF Beasley
2533 Firethorn Ct
Gastonia, NC 28056
jrsilverfox@hotmail.com
(704) 616-8474

This message was sent by KnowWho, as a service provider only, on behalf of the individual noted in the sender information.

From: charles smith (turtle130@hotmail.com) Sent You a Personal Message
To: [daq.NC_VWGrants](#)
Subject: [External] Use Volkswagen funds to electrify NC transportation
Date: Tuesday, December 05, 2017 5:02:18 PM

CAUTION: External email. Do not click links or open attachments unless verified. Send all suspicious email as an attachment to report.spam@nc.gov.

Dear Division of Air Quality,

I am writing to urge DEQ to wisely invest the \$92 million in Volkswagen settlement funds in electric vehicles and infrastructure. Taking advantage of these funds to jumpstart the electrification of North Carolina's transportation sector will mean less money sent out of state for petroleum, more in-state jobs, and cleaner air.

Specifically, I recommend that DEQ allocate the maximum allowable amount (15%) of the funds for electric vehicle charging infrastructure and installations. And I encourage DEQ to prioritize electric vehicles and buses for replacement whenever possible with the other 85% of the settlement funds. Doing so will maximize the local economic impact and the reduction of air pollution.

I encourage you to not use the funding for natural gas, propane or diesel vehicles. Further dependence on fossil fuels means more pollution. Only a transition to electric vehicles and investment in EV infrastructure will put us on the road to a 100% clean transportation sector in North Carolina.

Sincerely,

charles smith
5700 nassau dr
fayetteville, NC 28314
turtle130@hotmail.com
(910) 339-5211

This message was sent by KnowWho, as a service provider only, on behalf of the individual noted in the sender information.

From: Scott Hunziker (hunziker44@gmail.com) Sent You a Personal Message
To: [daq.NC_VWGrants](#)
Subject: [External] Use Volkswagen funds to electrify NC transportation
Date: Tuesday, December 05, 2017 5:02:15 PM

CAUTION: External email. Do not click links or open attachments unless verified. Send all suspicious email as an attachment to report.spam@nc.gov.

Dear Division of Air Quality,

I am writing to urge DEQ to wisely invest the \$92 million in Volkswagen settlement funds in electric vehicles and infrastructure. Taking advantage of these funds to jumpstart the electrification of North Carolina's transportation sector will mean less money sent out of state for petroleum, more in-state jobs, and cleaner air.

Specifically, I recommend that DEQ allocate the maximum allowable amount (15%) of the funds for electric vehicle charging infrastructure and installations. And I encourage DEQ to prioritize electric vehicles and buses for replacement whenever possible with the other 85% of the settlement funds. Doing so will maximize the local economic impact and the reduction of air pollution.

I encourage you to not use the funding for natural gas, propane or diesel vehicles. Further dependence on fossil fuels means more pollution. Only a transition to electric vehicles and investment in EV infrastructure will put us on the road to a 100% clean transportation sector in North Carolina.

Sincerely,

Scott Hunziker
49 ChickadeeTrail
Pittsboro, NC 28312
hunziker44@gmail.com
(203) 994-7028

This message was sent by KnowWho, as a service provider only, on behalf of the individual noted in the sender information.

From: Walter Kross (wkrb5@yahoo.com) Sent You a Personal Message
To: [daq.NC_VWGrants](#)
Subject: [External] Use Volkswagen funds to electrify NC transportation
Date: Tuesday, December 05, 2017 5:02:10 PM

CAUTION: External email. Do not click links or open attachments unless verified. Send all suspicious email as an attachment to report.spam@nc.gov.

Dear Division of Air Quality,

I am writing to urge DEQ to wisely invest the \$92 million in Volkswagen settlement funds in electric vehicles and infrastructure. Taking advantage of these funds to jumpstart the electrification of North Carolina's transportation sector will mean less money sent out of state for petroleum, more in-state jobs, and cleaner air.

Specifically, I recommend that DEQ allocate the maximum allowable amount (15%) of the funds for electric vehicle charging infrastructure and installations. And I encourage DEQ to prioritize electric vehicles and buses for replacement whenever possible with the other 85% of the settlement funds. Doing so will maximize the local economic impact and the reduction of air pollution.

I encourage you to not use the funding for natural gas, propane or diesel vehicles. Further dependence on fossil fuels means more pollution. Only a transition to electric vehicles and investment in EV infrastructure will put us on the road to a 100% clean transportation sector in North Carolina.

Sincerely,

Walter Kross
32 Imperial Dr
Hendersonville, NC 28792
wkrb5@yahoo.com
(609) 954-2176

This message was sent by KnowWho, as a service provider only, on behalf of the individual noted in the sender information.

From: Valerie Fox (valeriefox47@gmail.com) Sent You a Personal Message
To: [daq.NC_VWGrants](#)
Subject: [External] Use Volkswagen funds to electrify NC transportation
Date: Tuesday, December 05, 2017 5:01:04 PM

CAUTION: External email. Do not click links or open attachments unless verified. Send all suspicious email as an attachment to report.spam@nc.gov.

Dear Division of Air Quality,

I am writing to urge DEQ to wisely invest the \$92 million in Volkswagen settlement funds in electric vehicles and infrastructure. Taking advantage of these funds to jumpstart the electrification of North Carolina's transportation sector will mean less money sent out of state for petroleum, more in-state jobs, and cleaner air.

Specifically, I recommend that DEQ allocate the maximum allowable amount (15%) of the funds for electric vehicle charging infrastructure and installations. And I encourage DEQ to prioritize electric vehicles and buses for replacement whenever possible with the other 85% of the settlement funds. Doing so will maximize the local economic impact and the reduction of air pollution.

I encourage you to not use the funding for natural gas, propane or diesel vehicles. Further dependence on fossil fuels means more pollution. Only a transition to electric vehicles and investment in EV infrastructure will put us on the road to a 100% clean transportation sector in North Carolina.

Sincerely,

Valerie Fox
1331 Valley Run
Valerie, NC 27707
valeriefox47@gmail.com
(252) 213-0744

This message was sent by KnowWho, as a service provider only, on behalf of the individual noted in the sender information.

From: Tim Harris (jrby88@yahoo.com) Sent You a Personal Message
To: [daq.NC_VWGrants](#)
Subject: [External] Use Volkswagen funds to electrify NC transportation
Date: Tuesday, December 05, 2017 5:01:00 PM

CAUTION: External email. Do not click links or open attachments unless verified. Send all suspicious email as an attachment to report.spam@nc.gov.

Dear Division of Air Quality,

I am writing to urge DEQ to wisely invest the \$92 million in Volkswagen settlement funds in electric vehicles and infrastructure. Taking advantage of these funds to jumpstart the electrification of North Carolina's transportation sector will mean less money sent out of state for petroleum, more in-state jobs, and cleaner air.

Specifically, I recommend that DEQ allocate the maximum allowable amount (15%) of the funds for electric vehicle charging infrastructure and installations. And I encourage DEQ to prioritize electric vehicles and buses for replacement whenever possible with the other 85% of the settlement funds. Doing so will maximize the local economic impact and the reduction of air pollution.

I encourage you to not use the funding for natural gas, propane or diesel vehicles. Further dependence on fossil fuels means more pollution. Only a transition to electric vehicles and investment in EV infrastructure will put us on the road to a 100% clean transportation sector in North Carolina.

Sincerely,

Tim Harris
3815 Ranchwood Dr.
Clemmons, NC 27012
jrby88@yahoo.com
(336) 766-6975

This message was sent by KnowWho, as a service provider only, on behalf of the individual noted in the sender information.

From: Matthew Duffy (duffymediainc@gmail.com) Sent You a Personal Message
To: [daq.NC_VWGrants](#)
Subject: [External] Use Volkswagen funds to electrify NC transportation
Date: Tuesday, December 05, 2017 5:00:47 PM

CAUTION: External email. Do not click links or open attachments unless verified. Send all suspicious email as an attachment to report.spam@nc.gov.

Dear Division of Air Quality,

I am writing to urge DEQ to wisely invest the \$92 million in Volkswagen settlement funds in electric vehicles and infrastructure. Taking advantage of these funds to jumpstart the electrification of North Carolina's transportation sector will mean less money sent out of state for petroleum, more in-state jobs, and cleaner air.

Specifically, I recommend that DEQ allocate the maximum allowable amount (15%) of the funds for electric vehicle charging infrastructure and installations. And I encourage DEQ to prioritize electric vehicles and buses for replacement whenever possible with the other 85% of the settlement funds. Doing so will maximize the local economic impact and the reduction of air pollution.

I encourage you to not use the funding for natural gas, propane or diesel vehicles. Further dependence on fossil fuels means more pollution. Only a transition to electric vehicles and investment in EV infrastructure will put us on the road to a 100% clean transportation sector in North Carolina.

Sincerely,

Matthew Duffy
3820 Colby DRive
Raleigh, NC 27609
duffymediainc@gmail.com
(415) 876-4614

This message was sent by KnowWho, as a service provider only, on behalf of the individual noted in the sender information.

From: Lisa Premo (lpremo@carolina.rr.com) Sent You a Personal Message
To: [daq.NC_VWGrants](#)
Subject: [External] Use Volkswagen funds to electrify NC transportation
Date: Tuesday, December 05, 2017 4:59:07 PM

CAUTION: External email. Do not click links or open attachments unless verified. Send all suspicious email as an attachment to report.spam@nc.gov.

Dear Division of Air Quality,

I am writing to urge DEQ to wisely invest the \$92 million in Volkswagen settlement funds in electric vehicles and infrastructure. Taking advantage of these funds to jumpstart the electrification of North Carolina's transportation sector will mean less money sent out of state for petroleum, more in-state jobs, and cleaner air.

Specifically, I recommend that DEQ allocate the maximum allowable amount (15%) of the funds for electric vehicle charging infrastructure and installations. And I encourage DEQ to prioritize electric vehicles and buses for replacement whenever possible with the other 85% of the settlement funds. Doing so will maximize the local economic impact and the reduction of air pollution.

I encourage you to not use the funding for natural gas, propane or diesel vehicles. Further dependence on fossil fuels means more pollution. Only a transition to electric vehicles and investment in EV infrastructure will put us on the road to a 100% clean transportation sector in North Carolina.

Sincerely,

Lisa Premo
3417 Meadow Bluff Drive
Charlotte, NC 28226
lpremo@carolina.rr.com
(704) 960-9745

This message was sent by KnowWho, as a service provider only, on behalf of the individual noted in the sender information.

From: Debbie Watterson (debwatterson@gmail.com) Sent You a Personal Message
To: [daq.NC_VWGrants](#)
Subject: [External] Use Volkswagen funds to electrify NC transportation
Date: Tuesday, December 05, 2017 4:59:06 PM

CAUTION: External email. Do not click links or open attachments unless verified. Send all suspicious email as an attachment to report.spam@nc.gov.

Dear Division of Air Quality,

I am writing to urge DEQ to wisely invest the \$92 million in Volkswagen settlement funds in electric vehicles and infrastructure. Taking advantage of these funds to jumpstart the electrification of North Carolina's transportation sector will mean less money sent out of state for petroleum, more in-state jobs, and cleaner air.

Specifically, I recommend that DEQ allocate the maximum allowable amount (15%) of the funds for electric vehicle charging infrastructure and installations. And I encourage DEQ to prioritize electric vehicles and buses for replacement whenever possible with the other 85% of the settlement funds. Doing so will maximize the local economic impact and the reduction of air pollution.

I encourage you to not use the funding for natural gas, propane or diesel vehicles. Further dependence on fossil fuels means more pollution. Only a transition to electric vehicles and investment in EV infrastructure will put us on the road to a 100% clean transportation sector in North Carolina.

Sincerely,

Debbie Watterson
616 Loblolly Drive
Vass, NC 28394
debwatterson@gmail.com
(919) 274-0981

This message was sent by KnowWho, as a service provider only, on behalf of the individual noted in the sender information.

From: TP Jeffrey (9fb51935@opayq.com) Sent You a Personal Message
To: [daq.NC_VWGrants](#)
Subject: [External] Use Volkswagen funds to electrify NC transportation
Date: Tuesday, December 05, 2017 4:57:52 PM

CAUTION: External email. Do not click links or open attachments unless verified. Send all suspicious email as an attachment to report.spam@nc.gov.

Dear Division of Air Quality,

I am writing to urge DEQ to wisely invest the \$92 million in Volkswagen settlement funds in electric vehicles and infrastructure. Taking advantage of these funds to jumpstart the electrification of North Carolina's transportation sector will mean less money sent out of state for petroleum, more in-state jobs, and cleaner air.

Specifically, I recommend that DEQ allocate the maximum allowable amount (15%) of the funds for electric vehicle charging infrastructure and installations. And I encourage DEQ to prioritize electric vehicles and buses for replacement whenever possible with the other 85% of the settlement funds. Doing so will maximize the local economic impact and the reduction of air pollution.

I encourage you to not use the funding for natural gas, propane or diesel vehicles. Further dependence on fossil fuels means more pollution. Only a transition to electric vehicles and investment in EV infrastructure will put us on the road to a 100% clean transportation sector in North Carolina.

Sincerely,

TP Jeffrey
1001 Blazing Star
Monroe, NC 28110
9fb51935@opayq.com
(541) 728-9017

This message was sent by KnowWho, as a service provider only, on behalf of the individual noted in the sender information.

From: Miriam Angress (mials@duke.edu) Sent You a Personal Message
To: [daq.NC_VWGrants](#)
Subject: [External] Use Volkswagen funds to electrify NC transportation
Date: Tuesday, December 05, 2017 4:57:02 PM

CAUTION: External email. Do not click links or open attachments unless verified. Send all suspicious email as an attachment to report.spam@nc.gov.

Dear Division of Air Quality,

I am writing to urge DEQ to wisely invest the \$92 million in Volkswagen settlement funds in electric vehicles and infrastructure. Taking advantage of these funds to jumpstart the electrification of North Carolina's transportation sector will mean less money sent out of state for petroleum, more in-state jobs, and cleaner air.

Specifically, I recommend that DEQ allocate the maximum allowable amount (15%) of the funds for electric vehicle charging infrastructure and installations. And I encourage DEQ to prioritize electric vehicles and buses for replacement whenever possible with the other 85% of the settlement funds. Doing so will maximize the local economic impact and the reduction of air pollution.

I encourage you to not use the funding for natural gas, propane or diesel vehicles. Further dependence on fossil fuels means more pollution. Only a transition to electric vehicles and investment in EV infrastructure will put us on the road to a 100% clean transportation sector in North Carolina.

Sincerely,

Miriam Angress
2608 University Drive
Dur, NC 27707
mials@duke.edu
(919) 687-3601

This message was sent by KnowWho, as a service provider only, on behalf of the individual noted in the sender information.

From: Andrea Crook (andrea.crook@gmail.com) Sent You a Personal Message
To: [daq.NC_VWGrants](#)
Subject: [External] Use Volkswagen funds to electrify NC transportation
Date: Tuesday, December 05, 2017 4:56:57 PM

CAUTION: External email. Do not click links or open attachments unless verified. Send all suspicious email as an attachment to report.spam@nc.gov.

Dear Division of Air Quality,

I am writing to urge DEQ to wisely invest the \$92 million in Volkswagen settlement funds in electric vehicles and infrastructure. Taking advantage of these funds to jumpstart the electrification of North Carolina's transportation sector will mean less money sent out of state for petroleum, more in-state jobs, and cleaner air.

Specifically, I recommend that DEQ allocate the maximum allowable amount (15%) of the funds for electric vehicle charging infrastructure and installations. And I encourage DEQ to prioritize electric vehicles and buses for replacement whenever possible with the other 85% of the settlement funds. Doing so will maximize the local economic impact and the reduction of air pollution.

I encourage you to not use the funding for natural gas, propane or diesel vehicles. Further dependence on fossil fuels means more pollution. Only a transition to electric vehicles and investment in EV infrastructure will put us on the road to a 100% clean transportation sector in North Carolina.

Sincerely,

Andrea Crook
200 Kelly Rd
Sanford, NC 27332
andrea.crook@gmail.com
(910) 478-5092

This message was sent by KnowWho, as a service provider only, on behalf of the individual noted in the sender information.

From: Jess Perry (graycat228@yahoo.com) Sent You a Personal Message
To: [daq.NC_VWGrants](#)
Subject: [External] Use Volkswagen funds to electrify NC transportation
Date: Tuesday, December 05, 2017 4:56:37 PM

CAUTION: External email. Do not click links or open attachments unless verified. Send all suspicious email as an attachment to report.spam@nc.gov.

Dear Division of Air Quality,

I am writing to urge DEQ to wisely invest the \$92 million in Volkswagen settlement funds in electric vehicles and infrastructure. Taking advantage of these funds to jumpstart the electrification of North Carolina's transportation sector will mean less money sent out of state for petroleum, more in-state jobs, and cleaner air.

Specifically, I recommend that DEQ allocate the maximum allowable amount (15%) of the funds for electric vehicle charging infrastructure and installations. And I encourage DEQ to prioritize electric vehicles and buses for replacement whenever possible with the other 85% of the settlement funds. Doing so will maximize the local economic impact and the reduction of air pollution.

I encourage you to not use the funding for natural gas, propane or diesel vehicles. Further dependence on fossil fuels means more pollution. Only a transition to electric vehicles and investment in EV infrastructure will put us on the road to a 100% clean transportation sector in North Carolina.

Sincerely,

Jess Perry
201 Taylor St.
Jess, NC 27607
graycat228@yahoo.com
(919) 704-5565

This message was sent by KnowWho, as a service provider only, on behalf of the individual noted in the sender information.

From: Richard Boyles (richard@boyleshomeimprovement.com) Sent You a Personal Message
To: daq.NC_VWGrants
Subject: [External] Use Volkswagen funds to electrify NC transportation
Date: Tuesday, December 05, 2017 4:55:14 PM

CAUTION: External email. Do not click links or open attachments unless verified. Send all suspicious email as an attachment to report.spam@nc.gov.

Dear Division of Air Quality,

I am writing to urge DEQ to wisely invest the \$92 million in Volkswagen settlement funds in electric vehicles and infrastructure. Taking advantage of these funds to jumpstart the electrification of North Carolina's transportation sector will mean less money sent out of state for petroleum, more in-state jobs, and cleaner air.

Specifically, I recommend that DEQ allocate the maximum allowable amount (15%) of the funds for electric vehicle charging infrastructure and installations. And I encourage DEQ to prioritize electric vehicles and buses for replacement whenever possible with the other 85% of the settlement funds. Doing so will maximize the local economic impact and the reduction of air pollution.

I encourage you to not use the funding for natural gas, propane or diesel vehicles. Further dependence on fossil fuels means more pollution. Only a transition to electric vehicles and investment in EV infrastructure will put us on the road to a 100% clean transportation sector in North Carolina.

Sincerely,

Richard Boyles
3798 Samet Dr, Suite 102
HIGH POINT, NC 27265
richard@boyleshomeimprovement.com
(336) 869-3229

This message was sent by KnowWho, as a service provider only, on behalf of the individual noted in the sender information.

From: Suzy Lawrence (suzylawrence53@gmail.com) Sent You a Personal Message
To: [daq.NC_VWGrants](#)
Subject: [External] Use Volkswagen funds to electrify NC transportation
Date: Tuesday, December 05, 2017 4:54:59 PM

CAUTION: External email. Do not click links or open attachments unless verified. Send all suspicious email as an attachment to report.spam@nc.gov.

Dear Division of Air Quality,

I am writing to urge DEQ to wisely invest the \$92 million in Volkswagen settlement funds in electric vehicles and infrastructure. Taking advantage of these funds to jumpstart the electrification of North Carolina's transportation sector will mean less money sent out of state for petroleum, more in-state jobs, and cleaner air.

Specifically, I recommend that DEQ allocate the maximum allowable amount (15%) of the funds for electric vehicle charging infrastructure and installations. And I encourage DEQ to prioritize electric vehicles and buses for replacement whenever possible with the other 85% of the settlement funds. Doing so will maximize the local economic impact and the reduction of air pollution.

I encourage you to not use the funding for natural gas, propane or diesel vehicles. Further dependence on fossil fuels means more pollution. Only a transition to electric vehicles and investment in EV infrastructure will put us on the road to a 100% clean transportation sector in North Carolina.

Sincerely,

Suzy Lawrence
8622 Ryan Rd
Chapel Hill, NC 27516
suzylawrence53@gmail.com
(919) 619-6788

This message was sent by KnowWho, as a service provider only, on behalf of the individual noted in the sender information.

From: Jeff Kulp (jskulp1@gmail.com) Sent You a Personal Message
To: [daq.NC_VWGrants](#)
Subject: [External] Use Volkswagen funds to electrify NC transportation
Date: Tuesday, December 05, 2017 4:54:58 PM

CAUTION: External email. Do not click links or open attachments unless verified. Send all suspicious email as an attachment to report.spam@nc.gov.

Dear Division of Air Quality,

I am writing to urge DEQ to wisely invest the \$92 million in Volkswagen settlement funds in electric vehicles and infrastructure. Taking advantage of these funds to jumpstart the electrification of North Carolina's transportation sector will mean less money sent out of state for petroleum, more in-state jobs, and cleaner air.

Specifically, I recommend that DEQ allocate the maximum allowable amount (15%) of the funds for electric vehicle charging infrastructure and installations. And I encourage DEQ to prioritize electric vehicles and buses for replacement whenever possible with the other 85% of the settlement funds. Doing so will maximize the local economic impact and the reduction of air pollution.

I encourage you to not use the funding for natural gas, propane or diesel vehicles. Further dependence on fossil fuels means more pollution. Only a transition to electric vehicles and investment in EV infrastructure will put us on the road to a 100% clean transportation sector in North Carolina.

Sincerely,

Jeff Kulp
5417 Oldtowne Road
Raleigh, NC 27612
jskulp1@gmail.com
(919) 845-9813

This message was sent by KnowWho, as a service provider only, on behalf of the individual noted in the sender information.

From: Judith Butts (judybutts58@yahoo.com) Sent You a Personal Message
To: [daq.NC_VWGrants](#)
Subject: [External] Use Volkswagen funds to electrify NC transportation
Date: Tuesday, December 05, 2017 4:54:45 PM

CAUTION: External email. Do not click links or open attachments unless verified. Send all suspicious email as an attachment to report.spam@nc.gov.

Dear Division of Air Quality,

I am writing to urge DEQ to wisely invest the \$92 million in Volkswagen settlement funds in electric vehicles and infrastructure. Taking advantage of these funds to jumpstart the electrification of North Carolina's transportation sector will mean less money sent out of state for petroleum, more in-state jobs, and cleaner air.

Specifically, I recommend that DEQ allocate the maximum allowable amount (15%) of the funds for electric vehicle charging infrastructure and installations. And I encourage DEQ to prioritize electric vehicles and buses for replacement whenever possible with the other 85% of the settlement funds. Doing so will maximize the local economic impact and the reduction of air pollution.

I encourage you to not use the funding for natural gas, propane or diesel vehicles. Further dependence on fossil fuels means more pollution. Only a transition to electric vehicles and investment in EV infrastructure will put us on the road to a 100% clean transportation sector in North Carolina.

Sincerely,

Judith Butts
608 Vale Dr
Wilmington, NC 28411
judybutts58@yahoo.com
(303) 638-9963

This message was sent by KnowWho, as a service provider only, on behalf of the individual noted in the sender information.

From: Joe Bearden (chickadeebirders@gmail.com) Sent You a Personal Message
To: [daq.NC_VWGrants](#)
Subject: [External] Use Volkswagen funds to electrify NC transportation
Date: Tuesday, December 05, 2017 4:54:44 PM

CAUTION: External email. Do not click links or open attachments unless verified. Send all suspicious email as an attachment to report.spam@nc.gov.

Dear Division of Air Quality,

I am writing to urge DEQ to wisely invest the \$92 million in Volkswagen settlement funds in electric vehicles and infrastructure. Taking advantage of these funds to jumpstart the electrification of North Carolina's transportation sector will mean less money sent out of state for petroleum, more in-state jobs, and cleaner air.

Specifically, I recommend that DEQ allocate the maximum allowable amount (15%) of the funds for electric vehicle charging infrastructure and installations. And I encourage DEQ to prioritize electric vehicles and buses for replacement whenever possible with the other 85% of the settlement funds. Doing so will maximize the local economic impact and the reduction of air pollution.

I encourage you to not use the funding for natural gas, propane or diesel vehicles. Further dependence on fossil fuels means more pollution. Only a transition to electric vehicles and investment in EV infrastructure will put us on the road to a 100% clean transportation sector in North Carolina.

Sincerely,

Joe Bearden
1809 Lakepark Drive
Raleigh, NC 27612
chickadeebirders@gmail.com
(919) 844-9050

This message was sent by KnowWho, as a service provider only, on behalf of the individual noted in the sender information.

From: Kevin Jones (kevinfjones123@yahoo.com) Sent You a Personal Message
To: [daq.NC_VWGrants](#)
Subject: [External] Use Volkswagen funds to electrify NC transportation
Date: Tuesday, December 05, 2017 4:54:42 PM

CAUTION: External email. Do not click links or open attachments unless verified. Send all suspicious email as an attachment to report.spam@nc.gov.

Dear Division of Air Quality,

I am writing to urge DEQ to wisely invest the \$92 million in Volkswagen settlement funds in electric vehicles and infrastructure. Taking advantage of these funds to jumpstart the electrification of North Carolina's transportation sector will mean less money sent out of state for petroleum, more in-state jobs, and cleaner air.

Specifically, I recommend that DEQ allocate the maximum allowable amount (15%) of the funds for electric vehicle charging infrastructure and installations. And I encourage DEQ to prioritize electric vehicles and buses for replacement whenever possible with the other 85% of the settlement funds. Doing so will maximize the local economic impact and the reduction of air pollution.

I encourage you to not use the funding for natural gas, propane or diesel vehicles. Further dependence on fossil fuels means more pollution. Only a transition to electric vehicles and investment in EV infrastructure will put us on the road to a 100% clean transportation sector in North Carolina.

Sincerely,

Kevin Jones
1622 Maurice Trull Road
Wingate, NC 28174
kevinfjones123@yahoo.com
(619) 328-0097

This message was sent by KnowWho, as a service provider only, on behalf of the individual noted in the sender information.

From: Selena Cooper (orrostorm1@yahoo.com) Sent You a Personal Message
To: [daq.NC_VWGrants](#)
Subject: [External] Use Volkswagen funds to electrify NC transportation
Date: Tuesday, December 05, 2017 4:54:40 PM

CAUTION: External email. Do not click links or open attachments unless verified. Send all suspicious email as an attachment to report.spam@nc.gov.

Dear Division of Air Quality,

I am writing to urge DEQ to wisely invest the \$92 million in Volkswagen settlement funds in electric vehicles and infrastructure. Taking advantage of these funds to jumpstart the electrification of North Carolina's transportation sector will mean less money sent out of state for petroleum, more in-state jobs, and cleaner air.

Specifically, I recommend that DEQ allocate the maximum allowable amount (15%) of the funds for electric vehicle charging infrastructure and installations. And I encourage DEQ to prioritize electric vehicles and buses for replacement whenever possible with the other 85% of the settlement funds. Doing so will maximize the local economic impact and the reduction of air pollution.

I encourage you to not use the funding for natural gas, propane or diesel vehicles. Further dependence on fossil fuels means more pollution. Only a transition to electric vehicles and investment in EV infrastructure will put us on the road to a 100% clean transportation sector in North Carolina.

Sincerely,

Selena Cooper
1210 Deerfield Trace
Mebane, NC 27302
orrostorm1@yahoo.com
(937) 266-6541

This message was sent by KnowWho, as a service provider only, on behalf of the individual noted in the sender information.

From: Ralph Oliva (rgolivab52@aol.com) Sent You a Personal Message
To: [daq.NC_VWGrants](#)
Subject: [External] Use Volkswagen funds to electrify NC transportation
Date: Tuesday, December 05, 2017 4:54:39 PM

CAUTION: External email. Do not click links or open attachments unless verified. Send all suspicious email as an attachment to report.spam@nc.gov.

Dear Division of Air Quality,

I am writing to urge DEQ to wisely invest the \$92 million in Volkswagen settlement funds in electric vehicles and infrastructure. Taking advantage of these funds to jumpstart the electrification of North Carolina's transportation sector will mean less money sent out of state for petroleum, more in-state jobs, and cleaner air.

Specifically, I recommend that DEQ allocate the maximum allowable amount (15%) of the funds for electric vehicle charging infrastructure and installations. And I encourage DEQ to prioritize electric vehicles and buses for replacement whenever possible with the other 85% of the settlement funds. Doing so will maximize the local economic impact and the reduction of air pollution.

I encourage you to not use the funding for natural gas, propane or diesel vehicles. Further dependence on fossil fuels means more pollution. Only a transition to electric vehicles and investment in EV infrastructure will put us on the road to a 100% clean transportation sector in North Carolina.

Sincerely,

Ralph Oliva
4006 Bridgewood Lane
Charlotte, NC 28226
rgolivab52@aol.com
(704) 649-9236

This message was sent by KnowWho, as a service provider only, on behalf of the individual noted in the sender information.

From: Michelle Mitchell (michellemitchell@gmail.com) Sent You a Personal Message
To: [daq.NC_VWGrants](#)
Subject: [External] Use Volkswagen funds to electrify NC transportation
Date: Tuesday, December 05, 2017 4:54:18 PM

CAUTION: External email. Do not click links or open attachments unless verified. Send all suspicious email as an attachment to report.spam@nc.gov.

Dear Division of Air Quality,

I am writing to urge DEQ to wisely invest the \$92 million in Volkswagen settlement funds in electric vehicles and infrastructure. Taking advantage of these funds to jumpstart the electrification of North Carolina's transportation sector will mean less money sent out of state for petroleum, more in-state jobs, and cleaner air.

Specifically, I recommend that DEQ allocate the maximum allowable amount (15%) of the funds for electric vehicle charging infrastructure and installations. And I encourage DEQ to prioritize electric vehicles and buses for replacement whenever possible with the other 85% of the settlement funds. Doing so will maximize the local economic impact and the reduction of air pollution.

I encourage you to not use the funding for natural gas, propane or diesel vehicles. Further dependence on fossil fuels means more pollution. Only a transition to electric vehicles and investment in EV infrastructure will put us on the road to a 100% clean transportation sector in North Carolina.

Sincerely,

Michelle Mitchell
17227 Chardonnay Ct
Cornelius, NC 28031
michellemitchell@gmail.com
(704) 896-9629

This message was sent by KnowWho, as a service provider only, on behalf of the individual noted in the sender information.

From: Patricia Armistead (pgan00@gmail.com) Sent You a Personal Message
To: [daq.NC_VWGrants](#)
Subject: [External] Use Volkswagen funds to electrify NC transportation
Date: Tuesday, December 05, 2017 4:53:39 PM

CAUTION: External email. Do not click links or open attachments unless verified. Send all suspicious email as an attachment to report.spam@nc.gov.

Dear Division of Air Quality,

I am writing to urge DEQ to wisely invest the \$92 million in Volkswagen settlement funds in electric vehicles and infrastructure. Taking advantage of these funds to jumpstart the electrification of North Carolina's transportation sector will mean less money sent out of state for petroleum, more in-state jobs, and cleaner air.

Specifically, I recommend that DEQ allocate the maximum allowable amount (15%) of the funds for electric vehicle charging infrastructure and installations. And I encourage DEQ to prioritize electric vehicles and buses for replacement whenever possible with the other 85% of the settlement funds. Doing so will maximize the local economic impact and the reduction of air pollution.

I encourage you to not use the funding for natural gas, propane or diesel vehicles. Further dependence on fossil fuels means more pollution. Only a transition to electric vehicles and investment in EV infrastructure will put us on the road to a 100% clean transportation sector in North Carolina.

Sincerely,

Patricia Armistead
1605 WOOD DUCK LANE
KDH, NC 27948
pgan00@gmail.com
(252) 480-6446

This message was sent by KnowWho, as a service provider only, on behalf of the individual noted in the sender information.

From: Robert Hubbard (bobbhubbard@gmail.com) Sent You a Personal Message
To: [daq.NC_VWGrants](#)
Subject: [External] Use Volkswagen funds to electrify NC transportation
Date: Tuesday, December 05, 2017 4:53:38 PM

CAUTION: External email. Do not click links or open attachments unless verified. Send all suspicious email as an attachment to report.spam@nc.gov.

Dear Division of Air Quality,

I am writing to urge DEQ to wisely invest the \$92 million in Volkswagen settlement funds in electric vehicles and infrastructure. Taking advantage of these funds to jumpstart the electrification of North Carolina's transportation sector will mean less money sent out of state for petroleum, more in-state jobs, and cleaner air.

Specifically, I recommend that DEQ allocate the maximum allowable amount (15%) of the funds for electric vehicle charging infrastructure and installations. And I encourage DEQ to prioritize electric vehicles and buses for replacement whenever possible with the other 85% of the settlement funds. Doing so will maximize the local economic impact and the reduction of air pollution.

I encourage you to not use the funding for natural gas, propane or diesel vehicles. Further dependence on fossil fuels means more pollution. Only a transition to electric vehicles and investment in EV infrastructure will put us on the road to a 100% clean transportation sector in North Carolina.

Sincerely,

Robert Hubbard
3800 Shamrock Dr
Charlotte, NC 28215
bobbhubbard@gmail.com
(704) 532-7208

This message was sent by KnowWho, as a service provider only, on behalf of the individual noted in the sender information.

From: Cameron Gordon (cgordon404@gmail.com) Sent You a Personal Message
To: [daq.NC_VWGrants](#)
Subject: [External] Use Volkswagen funds to electrify NC transportation
Date: Tuesday, December 05, 2017 4:52:40 PM

CAUTION: External email. Do not click links or open attachments unless verified. Send all suspicious email as an attachment to report.spam@nc.gov.

Dear Division of Air Quality,

I am writing to urge DEQ to wisely invest the \$92 million in Volkswagen settlement funds in electric vehicles and infrastructure. Taking advantage of these funds to jumpstart the electrification of North Carolina's transportation sector will mean less money sent out of state for petroleum, more in-state jobs, and cleaner air.

Specifically, I recommend that DEQ allocate the maximum allowable amount (15%) of the funds for electric vehicle charging infrastructure and installations. And I encourage DEQ to prioritize electric vehicles and buses for replacement whenever possible with the other 85% of the settlement funds. Doing so will maximize the local economic impact and the reduction of air pollution.

I encourage you to not use the funding for natural gas, propane or diesel vehicles. Further dependence on fossil fuels means more pollution. Only a transition to electric vehicles and investment in EV infrastructure will put us on the road to a 100% clean transportation sector in North Carolina.

Sincerely,

Cameron Gordon
2901 N DAVIDSON ST, UNIT 138
CHARLOTTE, NC 28205
cgordon404@gmail.com
(925) 699-2110

This message was sent by KnowWho, as a service provider only, on behalf of the individual noted in the sender information.

From: Bethany Dusenberry (bad81548@gmail.com) Sent You a Personal Message
To: [daq.NC_VWGrants](#)
Subject: [External] Use Volkswagen funds to electrify NC transportation
Date: Tuesday, December 05, 2017 4:52:39 PM

CAUTION: External email. Do not click links or open attachments unless verified. Send all suspicious email as an attachment to report.spam@nc.gov.

Dear Division of Air Quality,

I am writing to urge DEQ to wisely invest the \$92 million in Volkswagen settlement funds in electric vehicles and infrastructure. Taking advantage of these funds to jumpstart the electrification of North Carolina's transportation sector will mean less money sent out of state for petroleum, more in-state jobs, and cleaner air.

Specifically, I recommend that DEQ allocate the maximum allowable amount (15%) of the funds for electric vehicle charging infrastructure and installations. And I encourage DEQ to prioritize electric vehicles and buses for replacement whenever possible with the other 85% of the settlement funds. Doing so will maximize the local economic impact and the reduction of air pollution.

I encourage you to not use the funding for natural gas, propane or diesel vehicles. Further dependence on fossil fuels means more pollution. Only a transition to electric vehicles and investment in EV infrastructure will put us on the road to a 100% clean transportation sector in North Carolina.

Sincerely,

Bethany Dusenberry
109 Cyprus Creek Lane
Hendersonville, NC 28791
bad81548@gmail.com
(828) 696-9876

This message was sent by KnowWho, as a service provider only, on behalf of the individual noted in the sender information.

From: Sharron Parker (parkersharron@aol.com) Sent You a Personal Message
To: [daq.NC_VWGrants](#)
Subject: [External] Use Volkswagen funds to electrify NC transportation
Date: Tuesday, December 05, 2017 4:52:18 PM

CAUTION: External email. Do not click links or open attachments unless verified. Send all suspicious email as an attachment to report.spam@nc.gov.

Dear Division of Air Quality,

I am writing to urge DEQ to wisely invest the \$92 million in Volkswagen settlement funds in electric vehicles and infrastructure. Taking advantage of these funds to jumpstart the electrification of North Carolina's transportation sector will mean less money sent out of state for petroleum, more in-state jobs, and cleaner air.

Specifically, I recommend that DEQ allocate the maximum allowable amount (15%) of the funds for electric vehicle charging infrastructure and installations. And I encourage DEQ to prioritize electric vehicles and buses for replacement whenever possible with the other 85% of the settlement funds. Doing so will maximize the local economic impact and the reduction of air pollution.

I encourage you to not use the funding for natural gas, propane or diesel vehicles. Further dependence on fossil fuels means more pollution. Only a transition to electric vehicles and investment in EV infrastructure will put us on the road to a 100% clean transportation sector in North Carolina.

Sincerely,

Sharron Parker
1500 River Mill Dr. #306
Wake Forest, NC 27587
parkersharron@aol.com
(919) 562-4056

This message was sent by KnowWho, as a service provider only, on behalf of the individual noted in the sender information.

From: Jo Ellen Hirsch (jehmd1@gmail.com) Sent You a Personal Message
To: [daq.NC_VWGrants](#)
Subject: [External] Use Volkswagen funds to electrify NC transportation
Date: Tuesday, December 05, 2017 4:52:06 PM

CAUTION: External email. Do not click links or open attachments unless verified. Send all suspicious email as an attachment to report.spam@nc.gov.

Dear Division of Air Quality,

I am writing to urge DEQ to wisely invest the \$92 million in Volkswagen settlement funds in electric vehicles and infrastructure. Taking advantage of these funds to jumpstart the electrification of North Carolina's transportation sector will mean less money sent out of state for petroleum, more in-state jobs, and cleaner air.

Specifically, I recommend that DEQ allocate the maximum allowable amount (15%) of the funds for electric vehicle charging infrastructure and installations. And I encourage DEQ to prioritize electric vehicles and buses for replacement whenever possible with the other 85% of the settlement funds. Doing so will maximize the local economic impact and the reduction of air pollution.

I encourage you to not use the funding for natural gas, propane or diesel vehicles. Further dependence on fossil fuels means more pollution. Only a transition to electric vehicles and investment in EV infrastructure will put us on the road to a 100% clean transportation sector in North Carolina.

Sincerely,

Jo Ellen Hirsch
307 Whitney Dr
Fayetteville, NC 28314
jehmd1@gmail.com
(910) 644-0284

This message was sent by KnowWho, as a service provider only, on behalf of the individual noted in the sender information.

From: Mary Buttitta (mary.buttitta@gmail.com) Sent You a Personal Message
To: [daq.NC_VWGrants](#)
Subject: [External] Use Volkswagen funds to electrify NC transportation
Date: Tuesday, December 05, 2017 4:52:05 PM

CAUTION: External email. Do not click links or open attachments unless verified. Send all suspicious email as an attachment to report.spam@nc.gov.

Dear Division of Air Quality,

I am writing to urge DEQ to wisely invest the \$92 million in Volkswagen settlement funds in electric vehicles and infrastructure. Taking advantage of these funds to jumpstart the electrification of North Carolina's transportation sector will mean less money sent out of state for petroleum, more in-state jobs, and cleaner air.

Specifically, I recommend that DEQ allocate the maximum allowable amount (15%) of the funds for electric vehicle charging infrastructure and installations. And I encourage DEQ to prioritize electric vehicles and buses for replacement whenever possible with the other 85% of the settlement funds. Doing so will maximize the local economic impact and the reduction of air pollution.

I encourage you to not use the funding for natural gas, propane or diesel vehicles. Further dependence on fossil fuels means more pollution. Only a transition to electric vehicles and investment in EV infrastructure will put us on the road to a 100% clean transportation sector in North Carolina.

Sincerely,

Mary Buttitta
411 Periwinkle Dr.
Asheville, NC 28804
mary.buttitta@gmail.com
(802) 373-0113

This message was sent by KnowWho, as a service provider only, on behalf of the individual noted in the sender information.

From: Marcia Hoeke (marhoeke@yahoo.com) Sent You a Personal Message
To: [daq.NC_VWGrants](#)
Subject: [External] Use Volkswagen funds to electrify NC transportation
Date: Tuesday, December 05, 2017 4:52:03 PM

CAUTION: External email. Do not click links or open attachments unless verified. Send all suspicious email as an attachment to report.spam@nc.gov.

Dear Division of Air Quality,

I am writing to urge DEQ to wisely invest the \$92 million in Volkswagen settlement funds in electric vehicles and infrastructure. Taking advantage of these funds to jumpstart the electrification of North Carolina's transportation sector will mean less money sent out of state for petroleum, more in-state jobs, and cleaner air.

Specifically, I recommend that DEQ allocate the maximum allowable amount (15%) of the funds for electric vehicle charging infrastructure and installations. And I encourage DEQ to prioritize electric vehicles and buses for replacement whenever possible with the other 85% of the settlement funds. Doing so will maximize the local economic impact and the reduction of air pollution.

I encourage you to not use the funding for natural gas, propane or diesel vehicles. Further dependence on fossil fuels means more pollution. Only a transition to electric vehicles and investment in EV infrastructure will put us on the road to a 100% clean transportation sector in North Carolina.

Sincerely,

Marcia Hoeke
47 Deer Run
Brevard, NC 28712
marhoeke@yahoo.com
(828) 384-2111

This message was sent by KnowWho, as a service provider only, on behalf of the individual noted in the sender information.

From: James Bowman (chiefbow@gmail.com) Sent You a Personal Message
To: [daq.NC_VWGrants](#)
Subject: [External] Use Volkswagen funds to electrify NC transportation
Date: Tuesday, December 05, 2017 4:52:00 PM

CAUTION: External email. Do not click links or open attachments unless verified. Send all suspicious email as an attachment to report.spam@nc.gov.

Dear Division of Air Quality,

I am writing to urge DEQ to wisely invest the \$92 million in Volkswagen settlement funds in electric vehicles and infrastructure. Taking advantage of these funds to jumpstart the electrification of North Carolina's transportation sector will mean less money sent out of state for petroleum, more in-state jobs, and cleaner air.

Specifically, I recommend that DEQ allocate the maximum allowable amount (15%) of the funds for electric vehicle charging infrastructure and installations. And I encourage DEQ to prioritize electric vehicles and buses for replacement whenever possible with the other 85% of the settlement funds. Doing so will maximize the local economic impact and the reduction of air pollution.

I encourage you to not use the funding for natural gas, propane or diesel vehicles. Further dependence on fossil fuels means more pollution. Only a transition to electric vehicles and investment in EV infrastructure will put us on the road to a 100% clean transportation sector in North Carolina.

Sincerely,

James Bowman
202 John Wesley Rd.
Greenville, NC 27858
chiefbow@gmail.com
(252) 830-8007

This message was sent by KnowWho, as a service provider only, on behalf of the individual noted in the sender information.

From: Carrie Fawcett (cjfawcett10821@gmail.com) Sent You a Personal Message
To: [daq.NC_VWGrants](#)
Subject: [External] Use Volkswagen funds to electrify NC transportation
Date: Tuesday, December 05, 2017 4:51:50 PM

CAUTION: External email. Do not click links or open attachments unless verified. Send all suspicious email as an attachment to report.spam@nc.gov.

Dear Division of Air Quality,

I am writing to urge DEQ to wisely invest the \$92 million in Volkswagen settlement funds in electric vehicles and infrastructure. Taking advantage of these funds to jumpstart the electrification of North Carolina's transportation sector will mean less money sent out of state for petroleum, more in-state jobs, and cleaner air.

Specifically, I recommend that DEQ allocate the maximum allowable amount (15%) of the funds for electric vehicle charging infrastructure and installations. And I encourage DEQ to prioritize electric vehicles and buses for replacement whenever possible with the other 85% of the settlement funds. Doing so will maximize the local economic impact and the reduction of air pollution.

I encourage you to not use the funding for natural gas, propane or diesel vehicles. Further dependence on fossil fuels means more pollution. Only a transition to electric vehicles and investment in EV infrastructure will put us on the road to a 100% clean transportation sector in North Carolina.

Sincerely,

Carrie Fawcett
10821 Redgrave Lane, Mint Hill, NC, United States
Mint Hill, NC 28227
cjfawcett10821@gmail.com
(704) 651-8054

This message was sent by KnowWho, as a service provider only, on behalf of the individual noted in the sender information.

From: Jo Ellen Hirsch (jehmd1@gmail.com) Sent You a Personal Message
To: [daq.NC_VWGrants](#)
Subject: [External] Use Volkswagen funds to electrify NC transportation
Date: Tuesday, December 05, 2017 4:51:47 PM

CAUTION: External email. Do not click links or open attachments unless verified. Send all suspicious email as an attachment to report.spam@nc.gov.

Dear Division of Air Quality,

I am writing to urge DEQ to wisely invest the \$92 million in Volkswagen settlement funds in electric vehicles and infrastructure. Taking advantage of these funds to jumpstart the electrification of North Carolina's transportation sector will mean less money sent out of state for petroleum, more in-state jobs, and cleaner air.

Specifically, I recommend that DEQ allocate the maximum allowable amount (15%) of the funds for electric vehicle charging infrastructure and installations. And I encourage DEQ to prioritize electric vehicles and buses for replacement whenever possible with the other 85% of the settlement funds. Doing so will maximize the local economic impact and the reduction of air pollution.

I encourage you to not use the funding for natural gas, propane or diesel vehicles. Further dependence on fossil fuels means more pollution. Only a transition to electric vehicles and investment in EV infrastructure will put us on the road to a 100% clean transportation sector in North Carolina.

Sincerely,

Jo Ellen Hirsch
307 Whitney Dr
Fayetteville, NC 28314
jehmd1@gmail.com
(910) 644-0284

This message was sent by KnowWho, as a service provider only, on behalf of the individual noted in the sender information.

From: James and Leslea Kunz (jimkunz44@gmail.com) Sent You a Personal Message
To: [daq.NC_VWGrants](#)
Subject: [External] Use Volkswagen funds to electrify NC transportation
Date: Tuesday, December 05, 2017 4:48:42 PM

CAUTION: External email. Do not click links or open attachments unless verified. Send all suspicious email as an attachment to report.spam@nc.gov.

Dear Division of Air Quality,

I am writing to urge DEQ to wisely invest the \$92 million in Volkswagen settlement funds in electric vehicles and infrastructure. Taking advantage of these funds to jumpstart the electrification of North Carolina's transportation sector will mean less money sent out of state for petroleum, more in-state jobs, and cleaner air.

Specifically, I recommend that DEQ allocate the maximum allowable amount (15%) of the funds for electric vehicle charging infrastructure and installations. And I encourage DEQ to prioritize electric vehicles and buses for replacement whenever possible with the other 85% of the settlement funds. Doing so will maximize the local economic impact and the reduction of air pollution.

I encourage you to not use the funding for natural gas, propane or diesel vehicles. Further dependence on fossil fuels means more pollution. Only a transition to electric vehicles and investment in EV infrastructure will put us on the road to a 100% clean transportation sector in North Carolina.

Sincerely,

James and Leslea Kunz
1218 Coral Reef Ct.
New Bern, NC 28560
jimkunz44@gmail.com
(252) 514-6670

This message was sent by KnowWho, as a service provider only, on behalf of the individual noted in the sender information.

From: Michael Barker (mbarkerua@gmail.com) Sent You a Personal Message
To: [daq.NC_VWGrants](#)
Subject: [External] Use Volkswagen funds to electrify NC transportation
Date: Tuesday, December 05, 2017 4:48:40 PM

CAUTION: External email. Do not click links or open attachments unless verified. Send all suspicious email as an attachment to report.spam@nc.gov.

Dear Division of Air Quality,

I am writing to urge DEQ to wisely invest the \$92 million in Volkswagen settlement funds in electric vehicles and infrastructure. Taking advantage of these funds to jumpstart the electrification of North Carolina's transportation sector will mean less money sent out of state for petroleum, more in-state jobs, and cleaner air.

Specifically, I recommend that DEQ allocate the maximum allowable amount (15%) of the funds for electric vehicle charging infrastructure and installations. And I encourage DEQ to prioritize electric vehicles and buses for replacement whenever possible with the other 85% of the settlement funds. Doing so will maximize the local economic impact and the reduction of air pollution.

I encourage you to not use the funding for natural gas, propane or diesel vehicles. Further dependence on fossil fuels means more pollution. Only a transition to electric vehicles and investment in EV infrastructure will put us on the road to a 100% clean transportation sector in North Carolina.

Sincerely,

Michael Barker
3125 Harris Mill Ln
Charlotte, NC 28262
mbarkerua@gmail.com
(256) 324-1534

This message was sent by KnowWho, as a service provider only, on behalf of the individual noted in the sender information.

From: thomas Lux (tomad234@yahoo.com) Sent You a Personal Message
To: daq.NC_VWGrants
Subject: [External] Use Volkswagen funds to electrify NC transportation
Date: Tuesday, December 05, 2017 4:48:06 PM

CAUTION: External email. Do not click links or open attachments unless verified. Send all suspicious email as an attachment to report.spam@nc.gov.

Dear Division of Air Quality,

I am writing to urge DEQ to wisely invest the \$92 million in Volkswagen settlement funds in electric vehicles and infrastructure. Taking advantage of these funds to jumpstart the electrification of North Carolina's transportation sector will mean less money sent out of state for petroleum, more in-state jobs, and cleaner air.

Specifically, I recommend that DEQ allocate the maximum allowable amount (15%) of the funds for electric vehicle charging infrastructure and installations. And I encourage DEQ to prioritize electric vehicles and buses for replacement whenever possible with the other 85% of the settlement funds. Doing so will maximize the local economic impact and the reduction of air pollution.

I encourage you to not use the funding for natural gas, propane or diesel vehicles. Further dependence on fossil fuels means more pollution. Only a transition to electric vehicles and investment in EV infrastructure will put us on the road to a 100% clean transportation sector in North Carolina.

Sincerely,

thomas Lux
154 franklin ln, ,
state road, NC 28676
tomad234@yahoo.com
(336) 835-5324

This message was sent by KnowWho, as a service provider only, on behalf of the individual noted in the sender information.

From: Brandy Meadows (branflakes12@hotmail.com) Sent You a Personal Message
To: [daq.NC_VWGrants](#)
Subject: [External] Use Volkswagen funds to electrify NC transportation
Date: Tuesday, December 05, 2017 4:47:46 PM

CAUTION: External email. Do not click links or open attachments unless verified. Send all suspicious email as an attachment to report.spam@nc.gov.

Dear Division of Air Quality,

I am writing to urge DEQ to wisely invest the \$92 million in Volkswagen settlement funds in electric vehicles and infrastructure. Taking advantage of these funds to jumpstart the electrification of North Carolina's transportation sector will mean less money sent out of state for petroleum, more in-state jobs, and cleaner air.

Specifically, I recommend that DEQ allocate the maximum allowable amount (15%) of the funds for electric vehicle charging infrastructure and installations. And I encourage DEQ to prioritize electric vehicles and buses for replacement whenever possible with the other 85% of the settlement funds. Doing so will maximize the local economic impact and the reduction of air pollution.

I encourage you to not use the funding for natural gas, propane or diesel vehicles. Further dependence on fossil fuels means more pollution. Only a transition to electric vehicles and investment in EV infrastructure will put us on the road to a 100% clean transportation sector in North Carolina.

Sincerely,

Brandy Meadows
4255 Birchwood Dr., Apt 107
Wilmington, NC 28405
branflakes12@hotmail.com
(704) 207-7701

This message was sent by KnowWho, as a service provider only, on behalf of the individual noted in the sender information.

From: Shelton Jenkins (sj45pta@yahoo.com) Sent You a Personal Message
To: [daq.NC_VWGrants](#)
Subject: [External] Use Volkswagen funds to electrify NC transportation
Date: Tuesday, December 05, 2017 4:45:40 PM

CAUTION: External email. Do not click links or open attachments unless verified. Send all suspicious email as an attachment to report.spam@nc.gov.

Dear Division of Air Quality,

I am writing to urge DEQ to wisely invest the \$92 million in Volkswagen settlement funds in electric vehicles and infrastructure. Taking advantage of these funds to jumpstart the electrification of North Carolina's transportation sector will mean less money sent out of state for petroleum, more in-state jobs, and cleaner air.

Specifically, I recommend that DEQ allocate the maximum allowable amount (15%) of the funds for electric vehicle charging infrastructure and installations. And I encourage DEQ to prioritize electric vehicles and buses for replacement whenever possible with the other 85% of the settlement funds. Doing so will maximize the local economic impact and the reduction of air pollution.

I encourage you to not use the funding for natural gas, propane or diesel vehicles. Further dependence on fossil fuels means more pollution. Only a transition to electric vehicles and investment in EV infrastructure will put us on the road to a 100% clean transportation sector in North Carolina.

Sincerely,

Shelton Jenkins
200 Fairmount Way
New Bern, NC 28562
sj45pta@yahoo.com
(252) 638-3686

This message was sent by KnowWho, as a service provider only, on behalf of the individual noted in the sender information.

From: Shoshana Serxner-Merchant (ssexner1124@att.net) Sent You a Personal Message
To: [daq.NC_VWGrants](#)
Subject: [External] Use Volkswagen funds to electrify NC transportation
Date: Tuesday, December 05, 2017 4:45:39 PM

CAUTION: External email. Do not click links or open attachments unless verified. Send all suspicious email as an attachment to report.spam@nc.gov.

Dear Division of Air Quality,

I am writing to urge DEQ to wisely invest the \$92 million in Volkswagen settlement funds in electric vehicles and infrastructure. Taking advantage of these funds to jumpstart the electrification of North Carolina's transportation sector will mean less money sent out of state for petroleum, more in-state jobs, and cleaner air.

Specifically, I recommend that DEQ allocate the maximum allowable amount (15%) of the funds for electric vehicle charging infrastructure and installations. And I encourage DEQ to prioritize electric vehicles and buses for replacement whenever possible with the other 85% of the settlement funds. Doing so will maximize the local economic impact and the reduction of air pollution.

I encourage you to not use the funding for natural gas, propane or diesel vehicles. Further dependence on fossil fuels means more pollution. Only a transition to electric vehicles and investment in EV infrastructure will put us on the road to a 100% clean transportation sector in North Carolina.

Sincerely,

Shoshana Serxner-Merchant
705 Dixie Tr.
Raleigh, NC 27607
ssexner1124@att.net
(919) 834-9406

This message was sent by KnowWho, as a service provider only, on behalf of the individual noted in the sender information.

From: Wendy Miller (wemiller1959@gmail.com) Sent You a Personal Message
To: [daq.NC_VWGrants](#)
Subject: [External] Use Volkswagen funds to electrify NC transportation
Date: Tuesday, December 05, 2017 4:45:17 PM

CAUTION: External email. Do not click links or open attachments unless verified. Send all suspicious email as an attachment to report.spam@nc.gov.

Dear Division of Air Quality,

I am writing to urge DEQ to wisely invest the \$92 million in Volkswagen settlement funds in electric vehicles and infrastructure. Taking advantage of these funds to jumpstart the electrification of North Carolina's transportation sector will mean less money sent out of state for petroleum, more in-state jobs, and cleaner air.

Specifically, I recommend that DEQ allocate the maximum allowable amount (15%) of the funds for electric vehicle charging infrastructure and installations. And I encourage DEQ to prioritize electric vehicles and buses for replacement whenever possible with the other 85% of the settlement funds. Doing so will maximize the local economic impact and the reduction of air pollution.

I encourage you to not use the funding for natural gas, propane or diesel vehicles. Further dependence on fossil fuels means more pollution. Only a transition to electric vehicles and investment in EV infrastructure will put us on the road to a 100% clean transportation sector in North Carolina.

Sincerely,

Wendy Miller
1915 New Sharon Church Road
Hillsborough, NC 27278
wemiller1959@gmail.com
(540) 421-9725

This message was sent by KnowWho, as a service provider only, on behalf of the individual noted in the sender information.

From: Danielle Richardet (daniellelr55@aol.com) Sent You a Personal Message
To: [daq.NC_VWGrants](#)
Subject: [External] Use Volkswagen funds to electrify NC transportation
Date: Tuesday, December 05, 2017 4:45:11 PM

CAUTION: External email. Do not click links or open attachments unless verified. Send all suspicious email as an attachment to report.spam@nc.gov.

Dear Division of Air Quality,

I am writing to urge DEQ to wisely invest the \$92 million in Volkswagen settlement funds in electric vehicles and infrastructure. Taking advantage of these funds to jumpstart the electrification of North Carolina's transportation sector will mean less money sent out of state for petroleum, more in-state jobs, and cleaner air.

Specifically, I recommend that DEQ allocate the maximum allowable amount (15%) of the funds for electric vehicle charging infrastructure and installations. And I encourage DEQ to prioritize electric vehicles and buses for replacement whenever possible with the other 85% of the settlement funds. Doing so will maximize the local economic impact and the reduction of air pollution.

I encourage you to not use the funding for natural gas, propane or diesel vehicles. Further dependence on fossil fuels means more pollution. Only a transition to electric vehicles and investment in EV infrastructure will put us on the road to a 100% clean transportation sector in North Carolina.

Sincerely,

Danielle Richardet
9100 Salem ct
Wilmington, NC 28411
daniellelr55@aol.com
(910) 465-0271

This message was sent by KnowWho, as a service provider only, on behalf of the individual noted in the sender information.

From: Lillian Swindell (lrhswindell@hotmail.com) Sent You a Personal Message
To: [daq.NC_VWGrants](#)
Subject: [External] Use Volkswagen funds to electrify NC transportation
Date: Tuesday, December 05, 2017 4:44:53 PM

CAUTION: External email. Do not click links or open attachments unless verified. Send all suspicious email as an attachment to report.spam@nc.gov.

Dear Division of Air Quality,

I am writing to urge DEQ to wisely invest the \$92 million in Volkswagen settlement funds in electric vehicles and infrastructure. Taking advantage of these funds to jumpstart the electrification of North Carolina's transportation sector will mean less money sent out of state for petroleum, more in-state jobs, and cleaner air.

Specifically, I recommend that DEQ allocate the maximum allowable amount (15%) of the funds for electric vehicle charging infrastructure and installations. And I encourage DEQ to prioritize electric vehicles and buses for replacement whenever possible with the other 85% of the settlement funds. Doing so will maximize the local economic impact and the reduction of air pollution.

I encourage you to not use the funding for natural gas, propane or diesel vehicles. Further dependence on fossil fuels means more pollution. Only a transition to electric vehicles and investment in EV infrastructure will put us on the road to a 100% clean transportation sector in North Carolina.

Sincerely,

Lillian Swindell
2118 Coniston Place
Charlotte, NC 28207
lrhswindell@hotmail.com
(704) 373-0139

This message was sent by KnowWho, as a service provider only, on behalf of the individual noted in the sender information.

From: Toni Wiker (earthmom1960@yahoo.com) Sent You a Personal Message
To: [daq.NC_VWGrants](#)
Subject: [External] Use Volkswagen funds to electrify NC transportation
Date: Tuesday, December 05, 2017 4:44:14 PM

CAUTION: External email. Do not click links or open attachments unless verified. Send all suspicious email as an attachment to report.spam@nc.gov.

Dear Division of Air Quality,

I am writing to urge DEQ to wisely invest the \$92 million in Volkswagen settlement funds in electric vehicles and infrastructure. Taking advantage of these funds to jumpstart the electrification of North Carolina's transportation sector will mean less money sent out of state for petroleum, more in-state jobs, and cleaner air.

Specifically, I recommend that DEQ allocate the maximum allowable amount (15%) of the funds for electric vehicle charging infrastructure and installations. And I encourage DEQ to prioritize electric vehicles and buses for replacement whenever possible with the other 85% of the settlement funds. Doing so will maximize the local economic impact and the reduction of air pollution.

I encourage you to not use the funding for natural gas, propane or diesel vehicles. Further dependence on fossil fuels means more pollution. Only a transition to electric vehicles and investment in EV infrastructure will put us on the road to a 100% clean transportation sector in North Carolina.

Sincerely,

Toni Wiker
106 Lee St
Jamestown, NC 27282
earthmom1960@yahoo.com
(336) 814-1332

This message was sent by KnowWho, as a service provider only, on behalf of the individual noted in the sender information.

From: DONALD HOUSER (jdhouser489@gmail.com) Sent You a Personal Message
To: [daq.NC_VWGrants](#)
Subject: [External] Use Volkswagen funds to electrify NC transportation
Date: Tuesday, December 05, 2017 4:44:12 PM

CAUTION: External email. Do not click links or open attachments unless verified. Send all suspicious email as an attachment to report.spam@nc.gov.

Dear Division of Air Quality,

I am writing to urge DEQ to wisely invest the \$92 million in Volkswagen settlement funds in electric vehicles and infrastructure. Taking advantage of these funds to jumpstart the electrification of North Carolina's transportation sector will mean less money sent out of state for petroleum, more in-state jobs, and cleaner air.

Specifically, I recommend that DEQ allocate the maximum allowable amount (15%) of the funds for electric vehicle charging infrastructure and installations. And I encourage DEQ to prioritize electric vehicles and buses for replacement whenever possible with the other 85% of the settlement funds. Doing so will maximize the local economic impact and the reduction of air pollution.

I encourage you to not use the funding for natural gas, propane or diesel vehicles. Further dependence on fossil fuels means more pollution. Only a transition to electric vehicles and investment in EV infrastructure will put us on the road to a 100% clean transportation sector in North Carolina.

Sincerely,

DONALD HOUSER
199 Cedardale Ct.
Clayton, NC 27520
jdhouser489@gmail.com
(919) 353-6864

This message was sent by KnowWho, as a service provider only, on behalf of the individual noted in the sender information.

From: Pat Harms (patron7@ec.rr.com) Sent You a Personal Message
To: [daq.NC_VWGrants](#)
Subject: [External] Use Volkswagen funds to electrify NC transportation
Date: Tuesday, December 05, 2017 4:44:10 PM

CAUTION: External email. Do not click links or open attachments unless verified. Send all suspicious email as an attachment to report.spam@nc.gov.

Dear Division of Air Quality,

I am writing to urge DEQ to wisely invest the \$92 million in Volkswagen settlement funds in electric vehicles and infrastructure. Taking advantage of these funds to jumpstart the electrification of North Carolina's transportation sector will mean less money sent out of state for petroleum, more in-state jobs, and cleaner air.

Specifically, I recommend that DEQ allocate the maximum allowable amount (15%) of the funds for electric vehicle charging infrastructure and installations. And I encourage DEQ to prioritize electric vehicles and buses for replacement whenever possible with the other 85% of the settlement funds. Doing so will maximize the local economic impact and the reduction of air pollution.

I encourage you to not use the funding for natural gas, propane or diesel vehicles. Further dependence on fossil fuels means more pollution. Only a transition to electric vehicles and investment in EV infrastructure will put us on the road to a 100% clean transportation sector in North Carolina.

Sincerely,

Pat Harms
814 S. Yaupon Terrace
Morehead City, NC 28557
patron7@ec.rr.com
(252) 764-7354

This message was sent by KnowWho, as a service provider only, on behalf of the individual noted in the sender information.

From: Farzana I (farzy19@yahoo.com) Sent You a Personal Message
To: [daq.NC_VWGrants](#)
Subject: [External] Use Volkswagen funds to electrify NC transportation
Date: Tuesday, December 05, 2017 4:43:46 PM

CAUTION: External email. Do not click links or open attachments unless verified. Send all suspicious email as an attachment to report.spam@nc.gov.

Dear Division of Air Quality,

I am writing to urge DEQ to wisely invest the \$92 million in Volkswagen settlement funds in electric vehicles and infrastructure. Taking advantage of these funds to jumpstart the electrification of North Carolina's transportation sector will mean less money sent out of state for petroleum, more in-state jobs, and cleaner air.

Specifically, I recommend that DEQ allocate the maximum allowable amount (15%) of the funds for electric vehicle charging infrastructure and installations. And I encourage DEQ to prioritize electric vehicles and buses for replacement whenever possible with the other 85% of the settlement funds. Doing so will maximize the local economic impact and the reduction of air pollution.

I encourage you to not use the funding for natural gas, propane or diesel vehicles. Further dependence on fossil fuels means more pollution. Only a transition to electric vehicles and investment in EV infrastructure will put us on the road to a 100% clean transportation sector in North Carolina.

Sincerely,

Farzana I
4303 Millis Road,
Jamestown, NC 27282
farzy19@yahoo.com
(732) 613-5799

This message was sent by KnowWho, as a service provider only, on behalf of the individual noted in the sender information.

From: J S (jillslee@aol.com) Sent You a Personal Message
To: [daq.NC_VWGrants](#)
Subject: [External] Use Volkswagen funds to electrify NC transportation
Date: Tuesday, December 05, 2017 4:43:32 PM

CAUTION: External email. Do not click links or open attachments unless verified. Send all suspicious email as an attachment to report.spam@nc.gov.

Dear Division of Air Quality,

I am writing to urge DEQ to wisely invest the \$92 million in Volkswagen settlement funds in electric vehicles and infrastructure. Taking advantage of these funds to jumpstart the electrification of North Carolina's transportation sector will mean less money sent out of state for petroleum, more in-state jobs, and cleaner air.

Specifically, I recommend that DEQ allocate the maximum allowable amount (15%) of the funds for electric vehicle charging infrastructure and installations. And I encourage DEQ to prioritize electric vehicles and buses for replacement whenever possible with the other 85% of the settlement funds. Doing so will maximize the local economic impact and the reduction of air pollution.

I encourage you to not use the funding for natural gas, propane or diesel vehicles. Further dependence on fossil fuels means more pollution. Only a transition to electric vehicles and investment in EV infrastructure will put us on the road to a 100% clean transportation sector in North Carolina.

Sincerely,

J S
14535 Harmonious St
Charlotte, NC 28278
jillslee@aol.com
(704) 643-9035

This message was sent by KnowWho, as a service provider only, on behalf of the individual noted in the sender information.

From: Cathy Nieman (cathy.nieman@gmail.com) Sent You a Personal Message
To: [daq.NC_VWGrants](#)
Subject: [External] Use Volkswagen funds to electrify NC transportation
Date: Tuesday, December 05, 2017 4:43:30 PM

CAUTION: External email. Do not click links or open attachments unless verified. Send all suspicious email as an attachment to report.spam@nc.gov.

Dear Division of Air Quality,

I am writing to urge DEQ to wisely invest the \$92 million in Volkswagen settlement funds in electric vehicles and infrastructure. Taking advantage of these funds to jumpstart the electrification of North Carolina's transportation sector will mean less money sent out of state for petroleum, more in-state jobs, and cleaner air.

Specifically, I recommend that DEQ allocate the maximum allowable amount (15%) of the funds for electric vehicle charging infrastructure and installations. And I encourage DEQ to prioritize electric vehicles and buses for replacement whenever possible with the other 85% of the settlement funds. Doing so will maximize the local economic impact and the reduction of air pollution.

I encourage you to not use the funding for natural gas, propane or diesel vehicles. Further dependence on fossil fuels means more pollution. Only a transition to electric vehicles and investment in EV infrastructure will put us on the road to a 100% clean transportation sector in North Carolina.

Sincerely,

Cathy Nieman
312 Ivy Hill Rd
Weaverville, NC 28787
cathy.nieman@gmail.com
(828) 555-5555

This message was sent by KnowWho, as a service provider only, on behalf of the individual noted in the sender information.

From: Marina Little (marinacestialfire4u2@yahoo.com) Sent You a Personal Message
To: [daq.NC_VWGrants](#)
Subject: [External] Use Volkswagen funds to electrify NC transportation
Date: Tuesday, December 05, 2017 4:43:08 PM

CAUTION: External email. Do not click links or open attachments unless verified. Send all suspicious email as an attachment to report.spam@nc.gov.

Dear Division of Air Quality,

I am writing to urge DEQ to wisely invest the \$92 million in Volkswagen settlement funds in electric vehicles and infrastructure. Taking advantage of these funds to jumpstart the electrification of North Carolina's transportation sector will mean less money sent out of state for petroleum, more in-state jobs, and cleaner air.

Specifically, I recommend that DEQ allocate the maximum allowable amount (15%) of the funds for electric vehicle charging infrastructure and installations. And I encourage DEQ to prioritize electric vehicles and buses for replacement whenever possible with the other 85% of the settlement funds. Doing so will maximize the local economic impact and the reduction of air pollution.

I encourage you to not use the funding for natural gas, propane or diesel vehicles. Further dependence on fossil fuels means more pollution. Only a transition to electric vehicles and investment in EV infrastructure will put us on the road to a 100% clean transportation sector in North Carolina.

Sincerely,

Marina Little
101 Pender Lane
Brevard, NC 28712
marinacestialfire4u2@yahoo.com
(941) 548-8750

This message was sent by KnowWho, as a service provider only, on behalf of the individual noted in the sender information.

From: Sandra Sotelo-Miller (sandra.sotelo@gmail.com) Sent You a Personal Message
To: [daq.NC_VWGrants](#)
Subject: [External] Use Volkswagen funds to electrify NC transportation
Date: Tuesday, December 05, 2017 4:42:45 PM

CAUTION: External email. Do not click links or open attachments unless verified. Send all suspicious email as an attachment to report.spam@nc.gov.

Dear Division of Air Quality,

I am writing to urge DEQ to wisely invest the \$92 million in Volkswagen settlement funds in electric vehicles and infrastructure. Taking advantage of these funds to jumpstart the electrification of North Carolina's transportation sector will mean less money sent out of state for petroleum, more in-state jobs, and cleaner air.

Specifically, I recommend that DEQ allocate the maximum allowable amount (15%) of the funds for electric vehicle charging infrastructure and installations. And I encourage DEQ to prioritize electric vehicles and buses for replacement whenever possible with the other 85% of the settlement funds. Doing so will maximize the local economic impact and the reduction of air pollution.

I encourage you to not use the funding for natural gas, propane or diesel vehicles. Further dependence on fossil fuels means more pollution. Only a transition to electric vehicles and investment in EV infrastructure will put us on the road to a 100% clean transportation sector in North Carolina.

Sincerely,

Sandra Sotelo-Miller
225 Linden Avenue
Raleigh, NC 27601
sandra.sotelo@gmail.com
(512) 541-5113

This message was sent by KnowWho, as a service provider only, on behalf of the individual noted in the sender information.

From: Marilyn Collins (tukki222@me.com) Sent You a Personal Message
To: [daq.NC_VWGrants](#)
Subject: [External] Use Volkswagen funds to electrify NC transportation
Date: Tuesday, December 05, 2017 4:42:43 PM

CAUTION: External email. Do not click links or open attachments unless verified. Send all suspicious email as an attachment to report.spam@nc.gov.

Dear Division of Air Quality,

I am writing to urge DEQ to wisely invest the \$92 million in Volkswagen settlement funds in electric vehicles and infrastructure. Taking advantage of these funds to jumpstart the electrification of North Carolina's transportation sector will mean less money sent out of state for petroleum, more in-state jobs, and cleaner air.

Specifically, I recommend that DEQ allocate the maximum allowable amount (15%) of the funds for electric vehicle charging infrastructure and installations. And I encourage DEQ to prioritize electric vehicles and buses for replacement whenever possible with the other 85% of the settlement funds. Doing so will maximize the local economic impact and the reduction of air pollution.

I encourage you to not use the funding for natural gas, propane or diesel vehicles. Further dependence on fossil fuels means more pollution. Only a transition to electric vehicles and investment in EV infrastructure will put us on the road to a 100% clean transportation sector in North Carolina.

Sincerely,

Marilyn Collins
POBox 12288
Wilmington, NC 28405
tukki222@me.com
(910) 547-1130

This message was sent by KnowWho, as a service provider only, on behalf of the individual noted in the sender information.

From: Deborah Beroth (daberoth@gmail.com) Sent You a Personal Message
To: [daq.NC_VWGrants](#)
Subject: [External] Use Volkswagen funds to electrify NC transportation
Date: Tuesday, December 05, 2017 4:42:42 PM

CAUTION: External email. Do not click links or open attachments unless verified. Send all suspicious email as an attachment to report.spam@nc.gov.

Dear Division of Air Quality,

I am writing to urge DEQ to wisely invest the \$92 million in Volkswagen settlement funds in electric vehicles and infrastructure. Taking advantage of these funds to jumpstart the electrification of North Carolina's transportation sector will mean less money sent out of state for petroleum, more in-state jobs, and cleaner air.

Specifically, I recommend that DEQ allocate the maximum allowable amount (15%) of the funds for electric vehicle charging infrastructure and installations. And I encourage DEQ to prioritize electric vehicles and buses for replacement whenever possible with the other 85% of the settlement funds. Doing so will maximize the local economic impact and the reduction of air pollution.

I encourage you to not use the funding for natural gas, propane or diesel vehicles. Further dependence on fossil fuels means more pollution. Only a transition to electric vehicles and investment in EV infrastructure will put us on the road to a 100% clean transportation sector in North Carolina.

Sincerely,

Deborah Beroth
6316 Lakeway dr
Raleigh, NC 27612
daberoth@gmail.com
(919) 870-1448

This message was sent by KnowWho, as a service provider only, on behalf of the individual noted in the sender information.

From: Michael Cooke (mcooke@ihsconsultations.com) Sent You a Personal Message
To: [daq.NC_VWGrants](#)
Subject: [External] Use Volkswagen funds to electrify NC transportation
Date: Tuesday, December 05, 2017 4:42:33 PM

CAUTION: External email. Do not click links or open attachments unless verified. Send all suspicious email as an attachment to report.spam@nc.gov.

Dear Division of Air Quality,

I am writing to urge DEQ to wisely invest the \$92 million in Volkswagen settlement funds in electric vehicles and infrastructure. Taking advantage of these funds to jumpstart the electrification of North Carolina's transportation sector will mean less money sent out of state for petroleum, more in-state jobs, and cleaner air.

Specifically, I recommend that DEQ allocate the maximum allowable amount (15%) of the funds for electric vehicle charging infrastructure and installations. And I encourage DEQ to prioritize electric vehicles and buses for replacement whenever possible with the other 85% of the settlement funds. Doing so will maximize the local economic impact and the reduction of air pollution.

I encourage you to not use the funding for natural gas, propane or diesel vehicles. Further dependence on fossil fuels means more pollution. Only a transition to electric vehicles and investment in EV infrastructure will put us on the road to a 100% clean transportation sector in North Carolina.

Sincerely,

Michael Cooke
249 Auto Park Drive, Ste 3
GRAHAM, NC 27253
mcooke@ihsconsultations.com
(336) 350-2744

This message was sent by KnowWho, as a service provider only, on behalf of the individual noted in the sender information.

From: Marie Swisher (kruzy030@yahoo.com) Sent You a Personal Message
To: daq.NC_VWGrants
Subject: [External] Use Volkswagen funds to electrify NC transportation
Date: Tuesday, December 05, 2017 4:42:26 PM

CAUTION: External email. Do not click links or open attachments unless verified. Send all suspicious email as an attachment to report.spam@nc.gov.

Dear Division of Air Quality,

I am writing to urge DEQ to wisely invest the \$92 million in Volkswagen settlement funds in electric vehicles and infrastructure. Taking advantage of these funds to jumpstart the electrification of North Carolina's transportation sector will mean less money sent out of state for petroleum, more in-state jobs, and cleaner air.

Specifically, I recommend that DEQ allocate the maximum allowable amount (15%) of the funds for electric vehicle charging infrastructure and installations. And I encourage DEQ to prioritize electric vehicles and buses for replacement whenever possible with the other 85% of the settlement funds. Doing so will maximize the local economic impact and the reduction of air pollution.

I encourage you to not use the funding for natural gas, propane or diesel vehicles. Further dependence on fossil fuels means more pollution. Only a transition to electric vehicles and investment in EV infrastructure will put us on the road to a 100% clean transportation sector in North Carolina.

Sincerely,

Marie Swisher
2100 Bald Mountain Rd
Burnsville, NC 28714
kruzy030@yahoo.com
(920) 369-0164

This message was sent by KnowWho, as a service provider only, on behalf of the individual noted in the sender information.

From: Aurelie Ward (health@wardgroup.net) Sent You a Personal Message
To: daq.NC_VWGrants
Subject: [External] Use Volkswagen funds to electrify NC transportation
Date: Tuesday, December 05, 2017 4:42:25 PM

CAUTION: External email. Do not click links or open attachments unless verified. Send all suspicious email as an attachment to report.spam@nc.gov.

Dear Division of Air Quality,

I am writing to urge DEQ to wisely invest the \$92 million in Volkswagen settlement funds in electric vehicles and infrastructure. Taking advantage of these funds to jumpstart the electrification of North Carolina's transportation sector will mean less money sent out of state for petroleum, more in-state jobs, and cleaner air.

Specifically, I recommend that DEQ allocate the maximum allowable amount (15%) of the funds for electric vehicle charging infrastructure and installations. And I encourage DEQ to prioritize electric vehicles and buses for replacement whenever possible with the other 85% of the settlement funds. Doing so will maximize the local economic impact and the reduction of air pollution.

I encourage you to not use the funding for natural gas, propane or diesel vehicles. Further dependence on fossil fuels means more pollution. Only a transition to electric vehicles and investment in EV infrastructure will put us on the road to a 100% clean transportation sector in North Carolina.

Sincerely,

Aurelie Ward
1409 Forest Park Drive
Statesville, NC 28677
health@wardgroup.net
(704) 871-1954

This message was sent by KnowWho, as a service provider only, on behalf of the individual noted in the sender information.

From: C Farmer (cfarmernc@gmail.com) Sent You a Personal Message
To: [daq.NC_VWGrants](#)
Subject: [External] Use Volkswagen funds to electrify NC transportation
Date: Tuesday, December 05, 2017 4:42:04 PM

CAUTION: External email. Do not click links or open attachments unless verified. Send all suspicious email as an attachment to report.spam@nc.gov.

Dear Division of Air Quality,

I am writing to urge DEQ to wisely invest the \$92 million in Volkswagen settlement funds in electric vehicles and infrastructure. Taking advantage of these funds to jumpstart the electrification of North Carolina's transportation sector will mean less money sent out of state for petroleum, more in-state jobs, and cleaner air.

Specifically, I recommend that DEQ allocate the maximum allowable amount (15%) of the funds for electric vehicle charging infrastructure and installations. And I encourage DEQ to prioritize electric vehicles and buses for replacement whenever possible with the other 85% of the settlement funds. Doing so will maximize the local economic impact and the reduction of air pollution.

I encourage you to not use the funding for natural gas, propane or diesel vehicles. Further dependence on fossil fuels means more pollution. Only a transition to electric vehicles and investment in EV infrastructure will put us on the road to a 100% clean transportation sector in North Carolina.

Sincerely,

C Farmer
199 Wilson Lake Rd
Mooresville, NC 28117
cfarmernc@gmail.com
(704) 658-0079

This message was sent by KnowWho, as a service provider only, on behalf of the individual noted in the sender information.

From: Laura Reynolds (pingvin1@aol.com) Sent You a Personal Message
To: [daq.NC_VWGrants](#)
Subject: [External] Use Volkswagen funds to electrify NC transportation
Date: Tuesday, December 05, 2017 4:41:59 PM

CAUTION: External email. Do not click links or open attachments unless verified. Send all suspicious email as an attachment to report.spam@nc.gov.

Dear Division of Air Quality,

I am writing to urge DEQ to wisely invest the \$92 million in Volkswagen settlement funds in electric vehicles and infrastructure. Taking advantage of these funds to jumpstart the electrification of North Carolina's transportation sector will mean less money sent out of state for petroleum, more in-state jobs, and cleaner air.

Specifically, I recommend that DEQ allocate the maximum allowable amount (15%) of the funds for electric vehicle charging infrastructure and installations. And I encourage DEQ to prioritize electric vehicles and buses for replacement whenever possible with the other 85% of the settlement funds. Doing so will maximize the local economic impact and the reduction of air pollution.

I encourage you to not use the funding for natural gas, propane or diesel vehicles. Further dependence on fossil fuels means more pollution. Only a transition to electric vehicles and investment in EV infrastructure will put us on the road to a 100% clean transportation sector in North Carolina.

Sincerely,

Laura Reynolds
1825 Austin Place Ln.
Winston Salem, NC 27127
pingvin1@aol.com
(910) 309-5549

This message was sent by KnowWho, as a service provider only, on behalf of the individual noted in the sender information.

From: Mary McQueen (meminavl@yahoo.com) Sent You a Personal Message
To: [daq.NC_VWGrants](#)
Subject: [External] Use Volkswagen funds to electrify NC transportation
Date: Tuesday, December 05, 2017 4:41:01 PM

CAUTION: External email. Do not click links or open attachments unless verified. Send all suspicious email as an attachment to report.spam@nc.gov.

Dear Division of Air Quality,

I am writing to urge DEQ to wisely invest the \$92 million in Volkswagen settlement funds in electric vehicles and infrastructure. Taking advantage of these funds to jumpstart the electrification of North Carolina's transportation sector will mean less money sent out of state for petroleum, more in-state jobs, and cleaner air.

Specifically, I recommend that DEQ allocate the maximum allowable amount (15%) of the funds for electric vehicle charging infrastructure and installations. And I encourage DEQ to prioritize electric vehicles and buses for replacement whenever possible with the other 85% of the settlement funds. Doing so will maximize the local economic impact and the reduction of air pollution.

I encourage you to not use the funding for natural gas, propane or diesel vehicles. Further dependence on fossil fuels means more pollution. Only a transition to electric vehicles and investment in EV infrastructure will put us on the road to a 100% clean transportation sector in North Carolina.

Sincerely,

Mary McQueen
171 Inglenook Rd.
Hendersonville, NC 28792
meminavl@yahoo.com
(828) 545-9010

This message was sent by KnowWho, as a service provider only, on behalf of the individual noted in the sender information.

From: Leslie Rupert (jlrupert@aol.com) Sent You a Personal Message
To: [daq.NC_VWGrants](#)
Subject: [External] Use Volkswagen funds to electrify NC transportation
Date: Tuesday, December 05, 2017 4:40:48 PM

CAUTION: External email. Do not click links or open attachments unless verified. Send all suspicious email as an attachment to report.spam@nc.gov.

Dear Division of Air Quality,

I am writing to urge DEQ to wisely invest the \$92 million in Volkswagen settlement funds in electric vehicles and infrastructure. Taking advantage of these funds to jumpstart the electrification of North Carolina's transportation sector will mean less money sent out of state for petroleum, more in-state jobs, and cleaner air.

Specifically, I recommend that DEQ allocate the maximum allowable amount (15%) of the funds for electric vehicle charging infrastructure and installations. And I encourage DEQ to prioritize electric vehicles and buses for replacement whenever possible with the other 85% of the settlement funds. Doing so will maximize the local economic impact and the reduction of air pollution.

I encourage you to not use the funding for natural gas, propane or diesel vehicles. Further dependence on fossil fuels means more pollution. Only a transition to electric vehicles and investment in EV infrastructure will put us on the road to a 100% clean transportation sector in North Carolina.

Sincerely,

Leslie Rupert
5309 Willow Cry Lane
Raleigh, NC 27613
jlrupert@aol.com
(919) 847-9701

This message was sent by KnowWho, as a service provider only, on behalf of the individual noted in the sender information.

From: Sandra Ricci (finlandinmind@protonmail.com) Sent You a Personal Message
To: [daq.NC_VWGrants](#)
Subject: [External] Use Volkswagen funds to electrify NC transportation
Date: Tuesday, December 05, 2017 4:40:44 PM

CAUTION: External email. Do not click links or open attachments unless verified. Send all suspicious email as an attachment to report.spam@nc.gov.

Dear Division of Air Quality,

I am writing to urge DEQ to wisely invest the \$92 million in Volkswagen settlement funds in electric vehicles and infrastructure. Taking advantage of these funds to jumpstart the electrification of North Carolina's transportation sector will mean less money sent out of state for petroleum, more in-state jobs, and cleaner air.

Specifically, I recommend that DEQ allocate the maximum allowable amount (15%) of the funds for electric vehicle charging infrastructure and installations. And I encourage DEQ to prioritize electric vehicles and buses for replacement whenever possible with the other 85% of the settlement funds. Doing so will maximize the local economic impact and the reduction of air pollution.

I encourage you to not use the funding for natural gas, propane or diesel vehicles. Further dependence on fossil fuels means more pollution. Only a transition to electric vehicles and investment in EV infrastructure will put us on the road to a 100% clean transportation sector in North Carolina.

Sincerely,

Sandra Ricci
6609 Battleford Drive
Raleigh, NC 27613
finlandinmind@protonmail.com
(919) 807-9782

This message was sent by KnowWho, as a service provider only, on behalf of the individual noted in the sender information.

From: Patricia White (pwhitehailey@yahoo.com) Sent You a Personal Message
To: [daq.NC_VWGrants](#)
Subject: [External] Use Volkswagen funds to electrify NC transportation
Date: Tuesday, December 05, 2017 4:40:16 PM

CAUTION: External email. Do not click links or open attachments unless verified. Send all suspicious email as an attachment to report.spam@nc.gov.

Dear Division of Air Quality,

I am writing to urge DEQ to wisely invest the \$92 million in Volkswagen settlement funds in electric vehicles and infrastructure. Taking advantage of these funds to jumpstart the electrification of North Carolina's transportation sector will mean less money sent out of state for petroleum, more in-state jobs, and cleaner air.

Specifically, I recommend that DEQ allocate the maximum allowable amount (15%) of the funds for electric vehicle charging infrastructure and installations. And I encourage DEQ to prioritize electric vehicles and buses for replacement whenever possible with the other 85% of the settlement funds. Doing so will maximize the local economic impact and the reduction of air pollution.

I encourage you to not use the funding for natural gas, propane or diesel vehicles. Further dependence on fossil fuels means more pollution. Only a transition to electric vehicles and investment in EV infrastructure will put us on the road to a 100% clean transportation sector in North Carolina.

Sincerely,

Patricia White
7 Spring Park Road
ASHEVILLE, NC 28805
pwhitehailey@yahoo.com
(404) 931-4895

This message was sent by KnowWho, as a service provider only, on behalf of the individual noted in the sender information.

From: Jesse Boeckermann (jessebach7@gmail.com) Sent You a Personal Message
To: [daq.NC_VWGrants](#)
Subject: [External] Use Volkswagen funds to electrify NC transportation
Date: Tuesday, December 05, 2017 4:38:46 PM

CAUTION: External email. Do not click links or open attachments unless verified. Send all suspicious email as an attachment to report.spam@nc.gov.

Dear Division of Air Quality,

I am writing to urge DEQ to wisely invest the \$92 million in Volkswagen settlement funds in electric vehicles and infrastructure. Taking advantage of these funds to jumpstart the electrification of North Carolina's transportation sector will mean less money sent out of state for petroleum, more in-state jobs, and cleaner air.

Specifically, I recommend that DEQ allocate the maximum allowable amount (15%) of the funds for electric vehicle charging infrastructure and installations. And I encourage DEQ to prioritize electric vehicles and buses for replacement whenever possible with the other 85% of the settlement funds. Doing so will maximize the local economic impact and the reduction of air pollution.

I encourage you to not use the funding for natural gas, propane or diesel vehicles. Further dependence on fossil fuels means more pollution. Only a transition to electric vehicles and investment in EV infrastructure will put us on the road to a 100% clean transportation sector in North Carolina.

Sincerely,

Jesse Boeckermann
102 Charles Ridge Road, Apt #
Asheville, NC 28805
jessebach7@gmail.com
(605) 376-4234

This message was sent by KnowWho, as a service provider only, on behalf of the individual noted in the sender information.

From: Brenda Rubens (bkrubens@gmail.com) Sent You a Personal Message
To: [daq.NC_VWGrants](#)
Subject: [External] Use Volkswagen funds to electrify NC transportation
Date: Tuesday, December 05, 2017 4:38:46 PM

CAUTION: External email. Do not click links or open attachments unless verified. Send all suspicious email as an attachment to report.spam@nc.gov.

Dear Division of Air Quality,

I am writing to urge DEQ to wisely invest the \$92 million in Volkswagen settlement funds in electric vehicles and infrastructure. Taking advantage of these funds to jumpstart the electrification of North Carolina's transportation sector will mean less money sent out of state for petroleum, more in-state jobs, and cleaner air.

Specifically, I recommend that DEQ allocate the maximum allowable amount (15%) of the funds for electric vehicle charging infrastructure and installations. And I encourage DEQ to prioritize electric vehicles and buses for replacement whenever possible with the other 85% of the settlement funds. Doing so will maximize the local economic impact and the reduction of air pollution.

I encourage you to not use the funding for natural gas, propane or diesel vehicles. Further dependence on fossil fuels means more pollution. Only a transition to electric vehicles and investment in EV infrastructure will put us on the road to a 100% clean transportation sector in North Carolina.

Sincerely,

Brenda Rubens
105 lakewater drive
Brenda, NC 27511
bkrubens@gmail.com
(919) 468-8886

This message was sent by KnowWho, as a service provider only, on behalf of the individual noted in the sender information.

From: Lauren Reker (lauren@mountaintrue.org) Sent You a Personal Message
To: [daq.NC_VWGrants](#)
Subject: [External] Use Volkswagen funds to electrify NC transportation
Date: Tuesday, December 05, 2017 4:38:37 PM

CAUTION: External email. Do not click links or open attachments unless verified. Send all suspicious email as an attachment to report.spam@nc.gov.

Dear Division of Air Quality,

I am writing to urge DEQ to wisely invest the \$92 million in Volkswagen settlement funds in electric vehicles and infrastructure. Taking advantage of these funds to jumpstart the electrification of North Carolina's transportation sector will mean less money sent out of state for petroleum, more in-state jobs, and cleaner air.

Specifically, I recommend that DEQ allocate the maximum allowable amount (15%) of the funds for electric vehicle charging infrastructure and installations. And I encourage DEQ to prioritize electric vehicles and buses for replacement whenever possible with the other 85% of the settlement funds. Doing so will maximize the local economic impact and the reduction of air pollution.

I encourage you to not use the funding for natural gas, propane or diesel vehicles. Further dependence on fossil fuels means more pollution. Only a transition to electric vehicles and investment in EV infrastructure will put us on the road to a 100% clean transportation sector in North Carolina.

Sincerely,

Lauren Reker
232 Eller Cove Rd
Weaverville, NC 28787
lauren@mountaintrue.org
(828) 484-8821

This message was sent by KnowWho, as a service provider only, on behalf of the individual noted in the sender information.

From: Georgina Jones (bihiyak@gmail.com) Sent You a Personal Message
To: [daq.NC_VWGrants](#)
Subject: [External] Use Volkswagen funds to electrify NC transportation
Date: Tuesday, December 05, 2017 4:38:34 PM

CAUTION: External email. Do not click links or open attachments unless verified. Send all suspicious email as an attachment to report.spam@nc.gov.

Dear Division of Air Quality,

I am writing to urge DEQ to wisely invest the \$92 million in Volkswagen settlement funds in electric vehicles and infrastructure. Taking advantage of these funds to jumpstart the electrification of North Carolina's transportation sector will mean less money sent out of state for petroleum, more in-state jobs, and cleaner air.

Specifically, I recommend that DEQ allocate the maximum allowable amount (15%) of the funds for electric vehicle charging infrastructure and installations. And I encourage DEQ to prioritize electric vehicles and buses for replacement whenever possible with the other 85% of the settlement funds. Doing so will maximize the local economic impact and the reduction of air pollution.

I encourage you to not use the funding for natural gas, propane or diesel vehicles. Further dependence on fossil fuels means more pollution. Only a transition to electric vehicles and investment in EV infrastructure will put us on the road to a 100% clean transportation sector in North Carolina.

Sincerely,

Georgina Jones
4808 Adler Pass
Raleigh, NC 27612
bihiyak@gmail.com
(919) 830-6491

This message was sent by KnowWho, as a service provider only, on behalf of the individual noted in the sender information.

From: Robert Farrell (rjf2000@gmail.com) Sent You a Personal Message
To: [daq.NC_VWGrants](#)
Subject: [External] Use Volkswagen funds to electrify NC transportation
Date: Tuesday, December 05, 2017 4:38:34 PM

CAUTION: External email. Do not click links or open attachments unless verified. Send all suspicious email as an attachment to report.spam@nc.gov.

Dear Division of Air Quality,

I am writing to urge DEQ to wisely invest the \$92 million in Volkswagen settlement funds in electric vehicles and infrastructure. Taking advantage of these funds to jumpstart the electrification of North Carolina's transportation sector will mean less money sent out of state for petroleum, more in-state jobs, and cleaner air.

Specifically, I recommend that DEQ allocate the maximum allowable amount (15%) of the funds for electric vehicle charging infrastructure and installations. And I encourage DEQ to prioritize electric vehicles and buses for replacement whenever possible with the other 85% of the settlement funds. Doing so will maximize the local economic impact and the reduction of air pollution.

I encourage you to not use the funding for natural gas, propane or diesel vehicles. Further dependence on fossil fuels means more pollution. Only a transition to electric vehicles and investment in EV infrastructure will put us on the road to a 100% clean transportation sector in North Carolina.

Sincerely,

Robert Farrell
285 Sabine Dr
Laurel Park, NC 28739
rjf2000@gmail.com
(908) 209-1614

This message was sent by KnowWho, as a service provider only, on behalf of the individual noted in the sender information.

From: Brandon stancil (stancil.brandon@gmail.com) Sent You a Personal Message
To: [daq.NC_VWGrants](#)
Subject: [External] Use Volkswagen funds to electrify NC transportation
Date: Tuesday, December 05, 2017 4:38:11 PM

CAUTION: External email. Do not click links or open attachments unless verified. Send all suspicious email as an attachment to report.spam@nc.gov.

Dear Division of Air Quality,

I am writing to urge DEQ to wisely invest the \$92 million in Volkswagen settlement funds in electric vehicles and infrastructure. Taking advantage of these funds to jumpstart the electrification of North Carolina's transportation sector will mean less money sent out of state for petroleum, more in-state jobs, and cleaner air.

Specifically, I recommend that DEQ allocate the maximum allowable amount (15%) of the funds for electric vehicle charging infrastructure and installations. And I encourage DEQ to prioritize electric vehicles and buses for replacement whenever possible with the other 85% of the settlement funds. Doing so will maximize the local economic impact and the reduction of air pollution.

I encourage you to not use the funding for natural gas, propane or diesel vehicles. Further dependence on fossil fuels means more pollution. Only a transition to electric vehicles and investment in EV infrastructure will put us on the road to a 100% clean transportation sector in North Carolina.

Sincerely,

Brandon stancil
404 N Laurel Ave #7
brandon, NC 28204
stancil.brandon@gmail.com
(704) 369-3820

This message was sent by KnowWho, as a service provider only, on behalf of the individual noted in the sender information.

From: Neely Hukill (neelyhukill@yahoo.com) Sent You a Personal Message
To: [daq.NC_VWGrants](#)
Subject: [External] Use Volkswagen funds to electrify NC transportation
Date: Tuesday, December 05, 2017 4:38:10 PM

CAUTION: External email. Do not click links or open attachments unless verified. Send all suspicious email as an attachment to report.spam@nc.gov.

Dear Division of Air Quality,

I am writing to urge DEQ to wisely invest the \$92 million in Volkswagen settlement funds in electric vehicles and infrastructure. Taking advantage of these funds to jumpstart the electrification of North Carolina's transportation sector will mean less money sent out of state for petroleum, more in-state jobs, and cleaner air.

Specifically, I recommend that DEQ allocate the maximum allowable amount (15%) of the funds for electric vehicle charging infrastructure and installations. And I encourage DEQ to prioritize electric vehicles and buses for replacement whenever possible with the other 85% of the settlement funds. Doing so will maximize the local economic impact and the reduction of air pollution.

I encourage you to not use the funding for natural gas, propane or diesel vehicles. Further dependence on fossil fuels means more pollution. Only a transition to electric vehicles and investment in EV infrastructure will put us on the road to a 100% clean transportation sector in North Carolina.

Sincerely,

Neely Hukill
408 St Kitts Ct
Holly Springs, NC 27540
neelyhukill@yahoo.com
(919) 586-2298

This message was sent by KnowWho, as a service provider only, on behalf of the individual noted in the sender information.

From: candace l (vt_cmonster@hotmail.com) Sent You a Personal Message
To: [daq.NC_VWGrants](#)
Subject: [External] Use Volkswagen funds to electrify NC transportation
Date: Tuesday, December 05, 2017 4:37:56 PM

CAUTION: External email. Do not click links or open attachments unless verified. Send all suspicious email as an attachment to report.spam@nc.gov.

Dear Division of Air Quality,

I am writing to urge DEQ to wisely invest the \$92 million in Volkswagen settlement funds in electric vehicles and infrastructure. Taking advantage of these funds to jumpstart the electrification of North Carolina's transportation sector will mean less money sent out of state for petroleum, more in-state jobs, and cleaner air.

Specifically, I recommend that DEQ allocate the maximum allowable amount (15%) of the funds for electric vehicle charging infrastructure and installations. And I encourage DEQ to prioritize electric vehicles and buses for replacement whenever possible with the other 85% of the settlement funds. Doing so will maximize the local economic impact and the reduction of air pollution.

I encourage you to not use the funding for natural gas, propane or diesel vehicles. Further dependence on fossil fuels means more pollution. Only a transition to electric vehicles and investment in EV infrastructure will put us on the road to a 100% clean transportation sector in North Carolina.

Sincerely,

candace l
3311 Marie
candace, NC 27604
vt_cmonster@hotmail.com
(919) 765-1000

This message was sent by KnowWho, as a service provider only, on behalf of the individual noted in the sender information.

From: Carole Newsome (jc_caldera@yahoo.com) Sent You a Personal Message
To: [daq.NC_VWGrants](#)
Subject: [External] Use Volkswagen funds to electrify NC transportation
Date: Tuesday, December 05, 2017 4:37:13 PM

CAUTION: External email. Do not click links or open attachments unless verified. Send all suspicious email as an attachment to report.spam@nc.gov.

Dear Division of Air Quality,

I am writing to urge DEQ to wisely invest the \$92 million in Volkswagen settlement funds in electric vehicles and infrastructure. Taking advantage of these funds to jumpstart the electrification of North Carolina's transportation sector will mean less money sent out of state for petroleum, more in-state jobs, and cleaner air.

Specifically, I recommend that DEQ allocate the maximum allowable amount (15%) of the funds for electric vehicle charging infrastructure and installations. And I encourage DEQ to prioritize electric vehicles and buses for replacement whenever possible with the other 85% of the settlement funds. Doing so will maximize the local economic impact and the reduction of air pollution.

I encourage you to not use the funding for natural gas, propane or diesel vehicles. Further dependence on fossil fuels means more pollution. Only a transition to electric vehicles and investment in EV infrastructure will put us on the road to a 100% clean transportation sector in North Carolina.

Sincerely,

Carole Newsome
7211 Emerald Dr
Emerald Isle, NC 28594
jc_caldera@yahoo.com
(910) 581-8108

This message was sent by KnowWho, as a service provider only, on behalf of the individual noted in the sender information.

From: Lauren Greenwood (lauren@pdcsoftware.com) Sent You a Personal Message
To: [daq.NC_VWGrants](#)
Subject: [External] Use Volkswagen funds to electrify NC transportation
Date: Tuesday, December 05, 2017 4:36:44 PM

CAUTION: External email. Do not click links or open attachments unless verified. Send all suspicious email as an attachment to report.spam@nc.gov.

Dear Division of Air Quality,

I am writing to urge DEQ to wisely invest the \$92 million in Volkswagen settlement funds in electric vehicles and infrastructure. Taking advantage of these funds to jumpstart the electrification of North Carolina's transportation sector will mean less money sent out of state for petroleum, more in-state jobs, and cleaner air.

Specifically, I recommend that DEQ allocate the maximum allowable amount (15%) of the funds for electric vehicle charging infrastructure and installations. And I encourage DEQ to prioritize electric vehicles and buses for replacement whenever possible with the other 85% of the settlement funds. Doing so will maximize the local economic impact and the reduction of air pollution.

I encourage you to not use the funding for natural gas, propane or diesel vehicles. Further dependence on fossil fuels means more pollution. Only a transition to electric vehicles and investment in EV infrastructure will put us on the road to a 100% clean transportation sector in North Carolina.

Sincerely,

Lauren Greenwood
1011 Shamrock Road
High Point, NC 27265
lauren@pdcsoftware.com
(336) 830-1682

This message was sent by KnowWho, as a service provider only, on behalf of the individual noted in the sender information.

From: Paul Cook (pcookecu@gmail.com) Sent You a Personal Message
To: [daq.NC_VWGrants](#)
Subject: [External] Use Volkswagen funds to electrify NC transportation
Date: Tuesday, December 05, 2017 4:36:35 PM

CAUTION: External email. Do not click links or open attachments unless verified. Send all suspicious email as an attachment to report.spam@nc.gov.

Dear Division of Air Quality,

I am writing to urge DEQ to wisely invest the \$92 million in Volkswagen settlement funds in electric vehicles and infrastructure. Taking advantage of these funds to jumpstart the electrification of North Carolina's transportation sector will mean less money sent out of state for petroleum, more in-state jobs, and cleaner air.

Specifically, I recommend that DEQ allocate the maximum allowable amount (15%) of the funds for electric vehicle charging infrastructure and installations. And I encourage DEQ to prioritize electric vehicles and buses for replacement whenever possible with the other 85% of the settlement funds. Doing so will maximize the local economic impact and the reduction of air pollution.

I encourage you to not use the funding for natural gas, propane or diesel vehicles. Further dependence on fossil fuels means more pollution. Only a transition to electric vehicles and investment in EV infrastructure will put us on the road to a 100% clean transportation sector in North Carolina.

Sincerely,

Paul Cook
101 Middleton Place
Greenville, NC 27858
pcookecu@gmail.com
(252) 754-4900

This message was sent by KnowWho, as a service provider only, on behalf of the individual noted in the sender information.

From: Taylor Smith (tjsmith19@gmail.com) Sent You a Personal Message
To: [daq.NC_VWGrants](#)
Subject: [External] Use Volkswagen funds to electrify NC transportation
Date: Tuesday, December 05, 2017 4:36:34 PM

CAUTION: External email. Do not click links or open attachments unless verified. Send all suspicious email as an attachment to report.spam@nc.gov.

Dear Division of Air Quality,

I am writing to urge DEQ to wisely invest the \$92 million in Volkswagen settlement funds in electric vehicles and infrastructure. Taking advantage of these funds to jumpstart the electrification of North Carolina's transportation sector will mean less money sent out of state for petroleum, more in-state jobs, and cleaner air.

Specifically, I recommend that DEQ allocate the maximum allowable amount (15%) of the funds for electric vehicle charging infrastructure and installations. And I encourage DEQ to prioritize electric vehicles and buses for replacement whenever possible with the other 85% of the settlement funds. Doing so will maximize the local economic impact and the reduction of air pollution.

I encourage you to not use the funding for natural gas, propane or diesel vehicles. Further dependence on fossil fuels means more pollution. Only a transition to electric vehicles and investment in EV infrastructure will put us on the road to a 100% clean transportation sector in North Carolina.

Sincerely,

Taylor Smith
125 Hudson St
Taylor, NC 27608
tjsmith19@gmail.com
(919) 389-7352

This message was sent by KnowWho, as a service provider only, on behalf of the individual noted in the sender information.

From: Lynn Hall (lahall78@gmail.com) Sent You a Personal Message
To: [daq.NC_VWGrants](#)
Subject: [External] Use Volkswagen funds to electrify NC transportation
Date: Tuesday, December 05, 2017 4:36:03 PM

CAUTION: External email. Do not click links or open attachments unless verified. Send all suspicious email as an attachment to report.spam@nc.gov.

Dear Division of Air Quality,

I am writing to urge DEQ to wisely invest the \$92 million in Volkswagen settlement funds in electric vehicles and infrastructure. Taking advantage of these funds to jumpstart the electrification of North Carolina's transportation sector will mean less money sent out of state for petroleum, more in-state jobs, and cleaner air.

Specifically, I recommend that DEQ allocate the maximum allowable amount (15%) of the funds for electric vehicle charging infrastructure and installations. And I encourage DEQ to prioritize electric vehicles and buses for replacement whenever possible with the other 85% of the settlement funds. Doing so will maximize the local economic impact and the reduction of air pollution.

I encourage you to not use the funding for natural gas, propane or diesel vehicles. Further dependence on fossil fuels means more pollution. Only a transition to electric vehicles and investment in EV infrastructure will put us on the road to a 100% clean transportation sector in North Carolina.

Sincerely,

Lynn Hall
70 Park ave N
Asheville, NC 28801
lahall78@gmail.com
(859) 608-6657

This message was sent by KnowWho, as a service provider only, on behalf of the individual noted in the sender information.

From: ted vaughan (tedvaughan42@gmail.com) Sent You a Personal Message
To: daq.NC_VWGrants
Subject: [External] Use Volkswagen funds to electrify NC transportation
Date: Tuesday, December 05, 2017 4:36:01 PM

CAUTION: External email. Do not click links or open attachments unless verified. Send all suspicious email as an attachment to report.spam@nc.gov.

Dear Division of Air Quality,

I am writing to urge DEQ to wisely invest the \$92 million in Volkswagen settlement funds in electric vehicles and infrastructure. Taking advantage of these funds to jumpstart the electrification of North Carolina's transportation sector will mean less money sent out of state for petroleum, more in-state jobs, and cleaner air.

Specifically, I recommend that DEQ allocate the maximum allowable amount (15%) of the funds for electric vehicle charging infrastructure and installations. And I encourage DEQ to prioritize electric vehicles and buses for replacement whenever possible with the other 85% of the settlement funds. Doing so will maximize the local economic impact and the reduction of air pollution.

I encourage you to not use the funding for natural gas, propane or diesel vehicles. Further dependence on fossil fuels means more pollution. Only a transition to electric vehicles and investment in EV infrastructure will put us on the road to a 100% clean transportation sector in North Carolina.

Sincerely,

ted vaughan
415 tanglewood trl
lake lure, NC 28746
tedvaughan42@gmail.com
(828) 625-1825

This message was sent by KnowWho, as a service provider only, on behalf of the individual noted in the sender information.

From: Randal Kempka (rkempka@carolina.rr.com) Sent You a Personal Message
To: [daq.NC_VWGrants](#)
Subject: [External] Use Volkswagen funds to electrify NC transportation
Date: Tuesday, December 05, 2017 4:35:37 PM

CAUTION: External email. Do not click links or open attachments unless verified. Send all suspicious email as an attachment to report.spam@nc.gov.

Dear Division of Air Quality,

I am writing to urge DEQ to wisely invest the \$92 million in Volkswagen settlement funds in electric vehicles and infrastructure. Taking advantage of these funds to jumpstart the electrification of North Carolina's transportation sector will mean less money sent out of state for petroleum, more in-state jobs, and cleaner air.

Specifically, I recommend that DEQ allocate the maximum allowable amount (15%) of the funds for electric vehicle charging infrastructure and installations. And I encourage DEQ to prioritize electric vehicles and buses for replacement whenever possible with the other 85% of the settlement funds. Doing so will maximize the local economic impact and the reduction of air pollution.

I encourage you to not use the funding for natural gas, propane or diesel vehicles. Further dependence on fossil fuels means more pollution. Only a transition to electric vehicles and investment in EV infrastructure will put us on the road to a 100% clean transportation sector in North Carolina.

Sincerely,

Randal Kempka
10018 White Cascade Drive
Charlotte, NC 28269
rkempka@carolina.rr.com
(704) 595-1776

This message was sent by KnowWho, as a service provider only, on behalf of the individual noted in the sender information.

From: Susan Redding (redding47@aol.com) Sent You a Personal Message
To: [daq.NC_VWGrants](#)
Subject: [External] Use Volkswagen funds to electrify NC transportation
Date: Tuesday, December 05, 2017 4:35:28 PM

CAUTION: External email. Do not click links or open attachments unless verified. Send all suspicious email as an attachment to report.spam@nc.gov.

Dear Division of Air Quality,

I am writing to urge DEQ to wisely invest the \$92 million in Volkswagen settlement funds in electric vehicles and infrastructure. Taking advantage of these funds to jumpstart the electrification of North Carolina's transportation sector will mean less money sent out of state for petroleum, more in-state jobs, and cleaner air.

Specifically, I recommend that DEQ allocate the maximum allowable amount (15%) of the funds for electric vehicle charging infrastructure and installations. And I encourage DEQ to prioritize electric vehicles and buses for replacement whenever possible with the other 85% of the settlement funds. Doing so will maximize the local economic impact and the reduction of air pollution.

I encourage you to not use the funding for natural gas, propane or diesel vehicles. Further dependence on fossil fuels means more pollution. Only a transition to electric vehicles and investment in EV infrastructure will put us on the road to a 100% clean transportation sector in North Carolina.

Sincerely,

Susan Redding
601 S. Elm St
Greenville, NC 27858
redding47@aol.com
(252) 758-7292

This message was sent by KnowWho, as a service provider only, on behalf of the individual noted in the sender information.

From: Eli Celli (elicelli@att.net) Sent You a Personal Message
To: [daq.NC_VWGrants](#)
Subject: [External] Use Volkswagen funds to electrify NC transportation
Date: Tuesday, December 05, 2017 4:35:06 PM

CAUTION: External email. Do not click links or open attachments unless verified. Send all suspicious email as an attachment to report.spam@nc.gov.

Dear Division of Air Quality,

I am writing to urge DEQ to wisely invest the \$92 million in Volkswagen settlement funds in electric vehicles and infrastructure. Taking advantage of these funds to jumpstart the electrification of North Carolina's transportation sector will mean less money sent out of state for petroleum, more in-state jobs, and cleaner air.

Specifically, I recommend that DEQ allocate the maximum allowable amount (15%) of the funds for electric vehicle charging infrastructure and installations. And I encourage DEQ to prioritize electric vehicles and buses for replacement whenever possible with the other 85% of the settlement funds. Doing so will maximize the local economic impact and the reduction of air pollution.

I encourage you to not use the funding for natural gas, propane or diesel vehicles. Further dependence on fossil fuels means more pollution. Only a transition to electric vehicles and investment in EV infrastructure will put us on the road to a 100% clean transportation sector in North Carolina.

Sincerely,

Eli Celli
407 Legends Way
Chapel Hill, NC 27516
elicelli@att.net
(919) 546-4109

This message was sent by KnowWho, as a service provider only, on behalf of the individual noted in the sender information.

From: Minnie White (minnie73@gmail.com) Sent You a Personal Message
To: [daq.NC_VWGrants](#)
Subject: [External] Use Volkswagen funds to electrify NC transportation
Date: Tuesday, December 05, 2017 4:35:03 PM

CAUTION: External email. Do not click links or open attachments unless verified. Send all suspicious email as an attachment to report.spam@nc.gov.

Dear Division of Air Quality,

I am writing to urge DEQ to wisely invest the \$92 million in Volkswagen settlement funds in electric vehicles and infrastructure. Taking advantage of these funds to jumpstart the electrification of North Carolina's transportation sector will mean less money sent out of state for petroleum, more in-state jobs, and cleaner air.

Specifically, I recommend that DEQ allocate the maximum allowable amount (15%) of the funds for electric vehicle charging infrastructure and installations. And I encourage DEQ to prioritize electric vehicles and buses for replacement whenever possible with the other 85% of the settlement funds. Doing so will maximize the local economic impact and the reduction of air pollution.

I encourage you to not use the funding for natural gas, propane or diesel vehicles. Further dependence on fossil fuels means more pollution. Only a transition to electric vehicles and investment in EV infrastructure will put us on the road to a 100% clean transportation sector in North Carolina.

Sincerely,

Minnie White
Po box 27
TARBORO, NC 27886
minnie73@gmail.com
(252) 886-1182

This message was sent by KnowWho, as a service provider only, on behalf of the individual noted in the sender information.

From: Janna Starr (jannastarr16@gmail.com) Sent You a Personal Message
To: [daq.NC_VWGrants](#)
Subject: [External] Use Volkswagen funds to electrify NC transportation
Date: Tuesday, December 05, 2017 4:35:02 PM

CAUTION: External email. Do not click links or open attachments unless verified. Send all suspicious email as an attachment to report.spam@nc.gov.

Dear Division of Air Quality,

I am writing to urge DEQ to wisely invest the \$92 million in Volkswagen settlement funds in electric vehicles and infrastructure. Taking advantage of these funds to jumpstart the electrification of North Carolina's transportation sector will mean less money sent out of state for petroleum, more in-state jobs, and cleaner air.

Specifically, I recommend that DEQ allocate the maximum allowable amount (15%) of the funds for electric vehicle charging infrastructure and installations. And I encourage DEQ to prioritize electric vehicles and buses for replacement whenever possible with the other 85% of the settlement funds. Doing so will maximize the local economic impact and the reduction of air pollution.

I encourage you to not use the funding for natural gas, propane or diesel vehicles. Further dependence on fossil fuels means more pollution. Only a transition to electric vehicles and investment in EV infrastructure will put us on the road to a 100% clean transportation sector in North Carolina.

Sincerely,

Janna Starr
114 E Murray Ave
Durham, NC 27704
jannastarr16@gmail.com
(703) 955-6008

This message was sent by KnowWho, as a service provider only, on behalf of the individual noted in the sender information.

From: Gavin Dillard (gavco@me.com) Sent You a Personal Message
To: [daq.NC_VWGrants](#)
Subject: [External] Use Volkswagen funds to electrify NC transportation
Date: Tuesday, December 05, 2017 4:35:02 PM

CAUTION: External email. Do not click links or open attachments unless verified. Send all suspicious email as an attachment to report.spam@nc.gov.

Dear Division of Air Quality,

I am writing to urge DEQ to wisely invest the \$92 million in Volkswagen settlement funds in electric vehicles and infrastructure. Taking advantage of these funds to jumpstart the electrification of North Carolina's transportation sector will mean less money sent out of state for petroleum, more in-state jobs, and cleaner air.

Specifically, I recommend that DEQ allocate the maximum allowable amount (15%) of the funds for electric vehicle charging infrastructure and installations. And I encourage DEQ to prioritize electric vehicles and buses for replacement whenever possible with the other 85% of the settlement funds. Doing so will maximize the local economic impact and the reduction of air pollution.

I encourage you to not use the funding for natural gas, propane or diesel vehicles. Further dependence on fossil fuels means more pollution. Only a transition to electric vehicles and investment in EV infrastructure will put us on the road to a 100% clean transportation sector in North Carolina.

Sincerely,

Gavin Dillard
528 Padgettown Road
Gavin, NC 28711
gavco@me.com
(828) 357-8069

This message was sent by KnowWho, as a service provider only, on behalf of the individual noted in the sender information.

From: Chas Griffin (cpgriff8@nc.rr.com) Sent You a Personal Message
To: [daq.NC_VWGrants](#)
Subject: [External] Use Volkswagen funds to electrify NC transportation
Date: Tuesday, December 05, 2017 4:35:00 PM

CAUTION: External email. Do not click links or open attachments unless verified. Send all suspicious email as an attachment to report.spam@nc.gov.

Dear Division of Air Quality,

I am writing to urge DEQ to wisely invest the \$92 million in Volkswagen settlement funds in electric vehicles and infrastructure. Taking advantage of these funds to jumpstart the electrification of North Carolina's transportation sector will mean less money sent out of state for petroleum, more in-state jobs, and cleaner air.

Specifically, I recommend that DEQ allocate the maximum allowable amount (15%) of the funds for electric vehicle charging infrastructure and installations. And I encourage DEQ to prioritize electric vehicles and buses for replacement whenever possible with the other 85% of the settlement funds. Doing so will maximize the local economic impact and the reduction of air pollution.

I encourage you to not use the funding for natural gas, propane or diesel vehicles. Further dependence on fossil fuels means more pollution. Only a transition to electric vehicles and investment in EV infrastructure will put us on the road to a 100% clean transportation sector in North Carolina.

Sincerely,

Chas Griffin
1275 Seven Lakes N.
Seven Lakes, NC 27376
cpgriff8@nc.rr.com
(910) 975-1673

This message was sent by KnowWho, as a service provider only, on behalf of the individual noted in the sender information.

From: Sara Warzecka (sarawarzecka@gmail.com) Sent You a Personal Message
To: [daq.NC_VWGrants](#)
Subject: [External] Use Volkswagen funds to electrify NC transportation
Date: Tuesday, December 05, 2017 4:34:59 PM

CAUTION: External email. Do not click links or open attachments unless verified. Send all suspicious email as an attachment to report.spam@nc.gov.

Dear Division of Air Quality,

I am writing to urge DEQ to wisely invest the \$92 million in Volkswagen settlement funds in electric vehicles and infrastructure. Taking advantage of these funds to jumpstart the electrification of North Carolina's transportation sector will mean less money sent out of state for petroleum, more in-state jobs, and cleaner air.

Specifically, I recommend that DEQ allocate the maximum allowable amount (15%) of the funds for electric vehicle charging infrastructure and installations. And I encourage DEQ to prioritize electric vehicles and buses for replacement whenever possible with the other 85% of the settlement funds. Doing so will maximize the local economic impact and the reduction of air pollution.

I encourage you to not use the funding for natural gas, propane or diesel vehicles. Further dependence on fossil fuels means more pollution. Only a transition to electric vehicles and investment in EV infrastructure will put us on the road to a 100% clean transportation sector in North Carolina.

Sincerely,

Sara Warzecka
80 Old Turnpike Rd
Mills river, NC 28759
sarawarzecka@gmail.com
(720) 437-0281

This message was sent by KnowWho, as a service provider only, on behalf of the individual noted in the sender information.

From: Rafael Agueda (ragueda05@yahoo.com) Sent You a Personal Message
To: [daq.NC_VWGrants](#)
Subject: [External] Use Volkswagen funds to electrify NC transportation
Date: Tuesday, December 05, 2017 4:34:57 PM

CAUTION: External email. Do not click links or open attachments unless verified. Send all suspicious email as an attachment to report.spam@nc.gov.

Dear Division of Air Quality,

I am writing to urge DEQ to wisely invest the \$92 million in Volkswagen settlement funds in electric vehicles and infrastructure. Taking advantage of these funds to jumpstart the electrification of North Carolina's transportation sector will mean less money sent out of state for petroleum, more in-state jobs, and cleaner air.

Specifically, I recommend that DEQ allocate the maximum allowable amount (15%) of the funds for electric vehicle charging infrastructure and installations. And I encourage DEQ to prioritize electric vehicles and buses for replacement whenever possible with the other 85% of the settlement funds. Doing so will maximize the local economic impact and the reduction of air pollution.

I encourage you to not use the funding for natural gas, propane or diesel vehicles. Further dependence on fossil fuels means more pollution. Only a transition to electric vehicles and investment in EV infrastructure will put us on the road to a 100% clean transportation sector in North Carolina.

Sincerely,

Rafael Agueda
4027 adair lane
Burlington, NC 27215
ragueda05@yahoo.com
(336) 253-3534

This message was sent by KnowWho, as a service provider only, on behalf of the individual noted in the sender information.

From: Rebecca Reid (reidrobustelli@gmail.com) Sent You a Personal Message
To: [daq.NC_VWGrants](#)
Subject: [External] Use Volkswagen funds to electrify NC transportation
Date: Tuesday, December 05, 2017 4:34:56 PM

CAUTION: External email. Do not click links or open attachments unless verified. Send all suspicious email as an attachment to report.spam@nc.gov.

Dear Division of Air Quality,

I am writing to urge DEQ to wisely invest the \$92 million in Volkswagen settlement funds in electric vehicles and infrastructure. Taking advantage of these funds to jumpstart the electrification of North Carolina's transportation sector will mean less money sent out of state for petroleum, more in-state jobs, and cleaner air.

Specifically, I recommend that DEQ allocate the maximum allowable amount (15%) of the funds for electric vehicle charging infrastructure and installations. And I encourage DEQ to prioritize electric vehicles and buses for replacement whenever possible with the other 85% of the settlement funds. Doing so will maximize the local economic impact and the reduction of air pollution.

I encourage you to not use the funding for natural gas, propane or diesel vehicles. Further dependence on fossil fuels means more pollution. Only a transition to electric vehicles and investment in EV infrastructure will put us on the road to a 100% clean transportation sector in North Carolina.

Sincerely,

Rebecca Reid
111 Breckenridge Ct.
Hendersonville, NC 28739
reidrobustelli@gmail.com
(828) 808-7051

This message was sent by KnowWho, as a service provider only, on behalf of the individual noted in the sender information.

From: Justin Landry (jl428182@yahoo.com) Sent You a Personal Message
To: [daq.NC_VWGrants](#)
Subject: [External] Use Volkswagen funds to electrify NC transportation
Date: Tuesday, December 05, 2017 4:34:55 PM

CAUTION: External email. Do not click links or open attachments unless verified. Send all suspicious email as an attachment to report.spam@nc.gov.

Dear Division of Air Quality,

I am writing to urge DEQ to wisely invest the \$92 million in Volkswagen settlement funds in electric vehicles and infrastructure. Taking advantage of these funds to jumpstart the electrification of North Carolina's transportation sector will mean less money sent out of state for petroleum, more in-state jobs, and cleaner air.

Specifically, I recommend that DEQ allocate the maximum allowable amount (15%) of the funds for electric vehicle charging infrastructure and installations. And I encourage DEQ to prioritize electric vehicles and buses for replacement whenever possible with the other 85% of the settlement funds. Doing so will maximize the local economic impact and the reduction of air pollution.

I encourage you to not use the funding for natural gas, propane or diesel vehicles. Further dependence on fossil fuels means more pollution. Only a transition to electric vehicles and investment in EV infrastructure will put us on the road to a 100% clean transportation sector in North Carolina.

Sincerely,

Justin Landry
18 Holland Street
Justin, NC 28801
jl428182@yahoo.com
(207) 735-3896

This message was sent by KnowWho, as a service provider only, on behalf of the individual noted in the sender information.

From: Stephen Boletchek (sboletchek@gmail.com) Sent You a Personal Message
To: [daq.NC_VWGrants](#)
Subject: [External] Use Volkswagen funds to electrify NC transportation
Date: Tuesday, December 05, 2017 4:32:47 PM

CAUTION: External email. Do not click links or open attachments unless verified. Send all suspicious email as an attachment to report.spam@nc.gov.

Dear Division of Air Quality,

I am writing to urge DEQ to wisely invest the \$92 million in Volkswagen settlement funds in electric vehicles and infrastructure. Taking advantage of these funds to jumpstart the electrification of North Carolina's transportation sector will mean less money sent out of state for petroleum, more in-state jobs, and cleaner air.

Specifically, I recommend that DEQ allocate the maximum allowable amount (15%) of the funds for electric vehicle charging infrastructure and installations. And I encourage DEQ to prioritize electric vehicles and buses for replacement whenever possible with the other 85% of the settlement funds. Doing so will maximize the local economic impact and the reduction of air pollution.

I encourage you to not use the funding for natural gas, propane or diesel vehicles. Further dependence on fossil fuels means more pollution. Only a transition to electric vehicles and investment in EV infrastructure will put us on the road to a 100% clean transportation sector in North Carolina.

Sincerely,

Stephen Boletchek
1106 Elbury Drive
Apex, NC 27502
sboletchek@gmail.com
(919) 387-9588

This message was sent by KnowWho, as a service provider only, on behalf of the individual noted in the sender information.

From: Barbara Hardie (bjhardie@gmail.com) Sent You a Personal Message
To: [daq.NC_VWGrants](#)
Subject: [External] Use Volkswagen funds to electrify NC transportation
Date: Tuesday, December 05, 2017 4:32:45 PM

CAUTION: External email. Do not click links or open attachments unless verified. Send all suspicious email as an attachment to report.spam@nc.gov.

Dear Division of Air Quality,

I am writing to urge DEQ to wisely invest the \$92 million in Volkswagen settlement funds in electric vehicles and infrastructure. Taking advantage of these funds to jumpstart the electrification of North Carolina's transportation sector will mean less money sent out of state for petroleum, more in-state jobs, and cleaner air.

Specifically, I recommend that DEQ allocate the maximum allowable amount (15%) of the funds for electric vehicle charging infrastructure and installations. And I encourage DEQ to prioritize electric vehicles and buses for replacement whenever possible with the other 85% of the settlement funds. Doing so will maximize the local economic impact and the reduction of air pollution.

I encourage you to not use the funding for natural gas, propane or diesel vehicles. Further dependence on fossil fuels means more pollution. Only a transition to electric vehicles and investment in EV infrastructure will put us on the road to a 100% clean transportation sector in North Carolina.

Sincerely,

Barbara Hardie
299 Connor Rd.
Sylva, NC 28779
bjhardie@gmail.com
(828) 331-0000

This message was sent by KnowWho, as a service provider only, on behalf of the individual noted in the sender information.

From: Zach Brown (zachmbrown@gmail.com) Sent You a Personal Message
To: [daq.NC_VWGrants](#)
Subject: [External] Use Volkswagen funds to electrify NC transportation
Date: Tuesday, December 05, 2017 4:32:02 PM

CAUTION: External email. Do not click links or open attachments unless verified. Send all suspicious email as an attachment to report.spam@nc.gov.

Dear Division of Air Quality,

I am writing to urge DEQ to wisely invest the \$92 million in Volkswagen settlement funds in electric vehicles and infrastructure. Taking advantage of these funds to jumpstart the electrification of North Carolina's transportation sector will mean less money sent out of state for petroleum, more in-state jobs, and cleaner air.

Specifically, I recommend that DEQ allocate the maximum allowable amount (15%) of the funds for electric vehicle charging infrastructure and installations. And I encourage DEQ to prioritize electric vehicles and buses for replacement whenever possible with the other 85% of the settlement funds. Doing so will maximize the local economic impact and the reduction of air pollution.

I encourage you to not use the funding for natural gas, propane or diesel vehicles. Further dependence on fossil fuels means more pollution. Only a transition to electric vehicles and investment in EV infrastructure will put us on the road to a 100% clean transportation sector in North Carolina.

Sincerely,

Zach Brown
3 White Ash Drive
Durham, NC 27712
zachmbrown@gmail.com
(336) 816-1615

This message was sent by KnowWho, as a service provider only, on behalf of the individual noted in the sender information.

From: R. Ross Holloway (r_holloway@brown.edu) Sent You a Personal Message
To: [daq.NC_VWGrants](#)
Subject: [External] Use Volkswagen funds to electrify NC transportation
Date: Tuesday, December 05, 2017 4:32:02 PM

CAUTION: External email. Do not click links or open attachments unless verified. Send all suspicious email as an attachment to report.spam@nc.gov.

Dear Division of Air Quality,

I am writing to urge DEQ to wisely invest the \$92 million in Volkswagen settlement funds in electric vehicles and infrastructure. Taking advantage of these funds to jumpstart the electrification of North Carolina's transportation sector will mean less money sent out of state for petroleum, more in-state jobs, and cleaner air.

Specifically, I recommend that DEQ allocate the maximum allowable amount (15%) of the funds for electric vehicle charging infrastructure and installations. And I encourage DEQ to prioritize electric vehicles and buses for replacement whenever possible with the other 85% of the settlement funds. Doing so will maximize the local economic impact and the reduction of air pollution.

I encourage you to not use the funding for natural gas, propane or diesel vehicles. Further dependence on fossil fuels means more pollution. Only a transition to electric vehicles and investment in EV infrastructure will put us on the road to a 100% clean transportation sector in North Carolina.

Sincerely,

R. Ross Holloway
711 West Main St.
Carrboro, NC 27510
r_holloway@brown.edu
(919) 942-2785

This message was sent by KnowWho, as a service provider only, on behalf of the individual noted in the sender information.

From: MW Matthews (online_traffic@icloud.com) Sent You a Personal Message
To: daq.NC_VWGrants
Subject: [External] Use Volkswagen funds to electrify NC transportation
Date: Tuesday, December 05, 2017 4:32:00 PM

CAUTION: External email. Do not click links or open attachments unless verified. Send all suspicious email as an attachment to report.spam@nc.gov.

Dear Division of Air Quality,

I am writing to urge DEQ to wisely invest the \$92 million in Volkswagen settlement funds in electric vehicles and infrastructure. Taking advantage of these funds to jumpstart the electrification of North Carolina's transportation sector will mean less money sent out of state for petroleum, more in-state jobs, and cleaner air.

Specifically, I recommend that DEQ allocate the maximum allowable amount (15%) of the funds for electric vehicle charging infrastructure and installations. And I encourage DEQ to prioritize electric vehicles and buses for replacement whenever possible with the other 85% of the settlement funds. Doing so will maximize the local economic impact and the reduction of air pollution.

I encourage you to not use the funding for natural gas, propane or diesel vehicles. Further dependence on fossil fuels means more pollution. Only a transition to electric vehicles and investment in EV infrastructure will put us on the road to a 100% clean transportation sector in North Carolina.

Sincerely,

MW Matthews
1323 WESTFIELD AVENUE
RALEIGH, NC 27607
online_traffic@icloud.com
(919) 783-8651

This message was sent by KnowWho, as a service provider only, on behalf of the individual noted in the sender information.

From: donna bender (dmbender14@yahoo.com) Sent You a Personal Message
To: [daq.NC_VWGrants](#)
Subject: [External] Use Volkswagen funds to electrify NC transportation
Date: Tuesday, December 05, 2017 4:31:14 PM

CAUTION: External email. Do not click links or open attachments unless verified. Send all suspicious email as an attachment to report.spam@nc.gov.

Dear Division of Air Quality,

I am writing to urge DEQ to wisely invest the \$92 million in Volkswagen settlement funds in electric vehicles and infrastructure. Taking advantage of these funds to jumpstart the electrification of North Carolina's transportation sector will mean less money sent out of state for petroleum, more in-state jobs, and cleaner air.

Specifically, I recommend that DEQ allocate the maximum allowable amount (15%) of the funds for electric vehicle charging infrastructure and installations. And I encourage DEQ to prioritize electric vehicles and buses for replacement whenever possible with the other 85% of the settlement funds. Doing so will maximize the local economic impact and the reduction of air pollution.

I encourage you to not use the funding for natural gas, propane or diesel vehicles. Further dependence on fossil fuels means more pollution. Only a transition to electric vehicles and investment in EV infrastructure will put us on the road to a 100% clean transportation sector in North Carolina.

Sincerely,

donna bender
1926 Carolina Bch Rd
Wilmington, NC 28401
dmbender14@yahoo.com
(910) 399-1810

This message was sent by KnowWho, as a service provider only, on behalf of the individual noted in the sender information.

From: David Moore (dsmoore6@gmail.com) Sent You a Personal Message
To: [daq.NC_VWGrants](#)
Subject: [External] Use Volkswagen funds to electrify NC transportation
Date: Tuesday, December 05, 2017 4:30:42 PM

CAUTION: External email. Do not click links or open attachments unless verified. Send all suspicious email as an attachment to report.spam@nc.gov.

Dear Division of Air Quality,

I am writing to urge DEQ to wisely invest the \$92 million in Volkswagen settlement funds in electric vehicles and infrastructure. Taking advantage of these funds to jumpstart the electrification of North Carolina's transportation sector will mean less money sent out of state for petroleum, more in-state jobs, and cleaner air.

Specifically, I recommend that DEQ allocate the maximum allowable amount (15%) of the funds for electric vehicle charging infrastructure and installations. And I encourage DEQ to prioritize electric vehicles and buses for replacement whenever possible with the other 85% of the settlement funds. Doing so will maximize the local economic impact and the reduction of air pollution.

I encourage you to not use the funding for natural gas, propane or diesel vehicles. Further dependence on fossil fuels means more pollution. Only a transition to electric vehicles and investment in EV infrastructure will put us on the road to a 100% clean transportation sector in North Carolina.

Sincerely,

David Moore
710 Lichfield Rd
Winston Salem, NC 27104
dsmoore6@gmail.com
(336) 575-5380

This message was sent by KnowWho, as a service provider only, on behalf of the individual noted in the sender information.

From: Andrew Cahan (gunghsi@bellsouth.net) Sent You a Personal Message
To: [daq.NC_VWGrants](#)
Subject: [External] Use Volkswagen funds to electrify NC transportation
Date: Tuesday, December 05, 2017 4:30:12 PM

CAUTION: External email. Do not click links or open attachments unless verified. Send all suspicious email as an attachment to report.spam@nc.gov.

Dear Division of Air Quality,

I am writing to urge DEQ to wisely invest the \$92 million in Volkswagen settlement funds in electric vehicles and infrastructure. Taking advantage of these funds to jumpstart the electrification of North Carolina's transportation sector will mean less money sent out of state for petroleum, more in-state jobs, and cleaner air.

Specifically, I recommend that DEQ allocate the maximum allowable amount (15%) of the funds for electric vehicle charging infrastructure and installations. And I encourage DEQ to prioritize electric vehicles and buses for replacement whenever possible with the other 85% of the settlement funds. Doing so will maximize the local economic impact and the reduction of air pollution.

I encourage you to not use the funding for natural gas, propane or diesel vehicles. Further dependence on fossil fuels means more pollution. Only a transition to electric vehicles and investment in EV infrastructure will put us on the road to a 100% clean transportation sector in North Carolina.

Sincerely,

Andrew Cahan
6400 Buckhorn Rd
Hillsborough, NC 27278
gunghsi@bellsouth.net
(919) 933-0009

This message was sent by KnowWho, as a service provider only, on behalf of the individual noted in the sender information.

From: Linda Campbell (lindagbc103@gmail.com) Sent You a Personal Message
To: [daq.NC_VWGrants](#)
Subject: [External] Use Volkswagen funds to electrify NC transportation
Date: Tuesday, December 05, 2017 4:30:02 PM

CAUTION: External email. Do not click links or open attachments unless verified. Send all suspicious email as an attachment to report.spam@nc.gov.

Dear Division of Air Quality,

I am writing to urge DEQ to wisely invest the \$92 million in Volkswagen settlement funds in electric vehicles and infrastructure. Taking advantage of these funds to jumpstart the electrification of North Carolina's transportation sector will mean less money sent out of state for petroleum, more in-state jobs, and cleaner air.

Specifically, I recommend that DEQ allocate the maximum allowable amount (15%) of the funds for electric vehicle charging infrastructure and installations. And I encourage DEQ to prioritize electric vehicles and buses for replacement whenever possible with the other 85% of the settlement funds. Doing so will maximize the local economic impact and the reduction of air pollution.

I encourage you to not use the funding for natural gas, propane or diesel vehicles. Further dependence on fossil fuels means more pollution. Only a transition to electric vehicles and investment in EV infrastructure will put us on the road to a 100% clean transportation sector in North Carolina.

Sincerely,

Linda Campbell
100 Victoria Court
Point Harbor, NC 27964
lindagbc103@gmail.com
(724) 941-4436

This message was sent by KnowWho, as a service provider only, on behalf of the individual noted in the sender information.

From: SAMAntha Winstead (samanthawinstead@icloud.com) Sent You a Personal Message
To: [daq.NC_VWGrants](#)
Subject: [External] Use Volkswagen funds to electrify NC transportation
Date: Tuesday, December 05, 2017 4:29:59 PM

CAUTION: External email. Do not click links or open attachments unless verified. Send all suspicious email as an attachment to report.spam@nc.gov.

Dear Division of Air Quality,

I am writing to urge DEQ to wisely invest the \$92 million in Volkswagen settlement funds in electric vehicles and infrastructure. Taking advantage of these funds to jumpstart the electrification of North Carolina's transportation sector will mean less money sent out of state for petroleum, more in-state jobs, and cleaner air.

Specifically, I recommend that DEQ allocate the maximum allowable amount (15%) of the funds for electric vehicle charging infrastructure and installations. And I encourage DEQ to prioritize electric vehicles and buses for replacement whenever possible with the other 85% of the settlement funds. Doing so will maximize the local economic impact and the reduction of air pollution.

I encourage you to not use the funding for natural gas, propane or diesel vehicles. Further dependence on fossil fuels means more pollution. Only a transition to electric vehicles and investment in EV infrastructure will put us on the road to a 100% clean transportation sector in North Carolina.

Sincerely,

SAMAntha Winstead
2738 Bancroft st
Charlotte, NC 28206
samanthawinstead@icloud.com
(270) 577-5739

This message was sent by KnowWho, as a service provider only, on behalf of the individual noted in the sender information.

From: Diego Rodriguez (darodriguez@me.com) Sent You a Personal Message
To: [daq.NC_VWGrants](#)
Subject: [External] Use Volkswagen funds to electrify NC transportation
Date: Tuesday, December 05, 2017 4:29:32 PM

CAUTION: External email. Do not click links or open attachments unless verified. Send all suspicious email as an attachment to report.spam@nc.gov.

Dear Division of Air Quality,

I am writing to urge DEQ to wisely invest the \$92 million in Volkswagen settlement funds in electric vehicles and infrastructure. Taking advantage of these funds to jumpstart the electrification of North Carolina's transportation sector will mean less money sent out of state for petroleum, more in-state jobs, and cleaner air.

Specifically, I recommend that DEQ allocate the maximum allowable amount (15%) of the funds for electric vehicle charging infrastructure and installations. And I encourage DEQ to prioritize electric vehicles and buses for replacement whenever possible with the other 85% of the settlement funds. Doing so will maximize the local economic impact and the reduction of air pollution.

I encourage you to not use the funding for natural gas, propane or diesel vehicles. Further dependence on fossil fuels means more pollution. Only a transition to electric vehicles and investment in EV infrastructure will put us on the road to a 100% clean transportation sector in North Carolina.

Sincerely,

Diego Rodriguez
131 Holly Berry Ln
Durham, NC 27703
darodriguez@me.com
(919) 801-9196

This message was sent by KnowWho, as a service provider only, on behalf of the individual noted in the sender information.

From: Donald Harland (dharland@bellsouth.net) Sent You a Personal Message
To: daq.NC_VWGrants
Subject: [External] Use Volkswagen funds to electrify NC transportation
Date: Tuesday, December 05, 2017 4:29:21 PM

CAUTION: External email. Do not click links or open attachments unless verified. Send all suspicious email as an attachment to report.spam@nc.gov.

Dear Division of Air Quality,

I am writing to urge DEQ to wisely invest the \$92 million in Volkswagen settlement funds in electric vehicles and infrastructure. Taking advantage of these funds to jumpstart the electrification of North Carolina's transportation sector will mean less money sent out of state for petroleum, more in-state jobs, and cleaner air.

Specifically, I recommend that DEQ allocate the maximum allowable amount (15%) of the funds for electric vehicle charging infrastructure and installations. And I encourage DEQ to prioritize electric vehicles and buses for replacement whenever possible with the other 85% of the settlement funds. Doing so will maximize the local economic impact and the reduction of air pollution.

I encourage you to not use the funding for natural gas, propane or diesel vehicles. Further dependence on fossil fuels means more pollution. Only a transition to electric vehicles and investment in EV infrastructure will put us on the road to a 100% clean transportation sector in North Carolina.

Sincerely,

Donald Harland
PO Box 2080, 677 N Luther Rd.
Candler, NC 28715
dharland@bellsouth.net
(828) 665-9247

This message was sent by KnowWho, as a service provider only, on behalf of the individual noted in the sender information.

From: Gloria Shirley (gloriaann922@yahoo.com) Sent You a Personal Message
To: [daq.NC_VWGrants](#)
Subject: [External] Use Volkswagen funds to electrify NC transportation
Date: Tuesday, December 05, 2017 4:29:15 PM

CAUTION: External email. Do not click links or open attachments unless verified. Send all suspicious email as an attachment to report.spam@nc.gov.

Dear Division of Air Quality,

I am writing to urge DEQ to wisely invest the \$92 million in Volkswagen settlement funds in electric vehicles and infrastructure. Taking advantage of these funds to jumpstart the electrification of North Carolina's transportation sector will mean less money sent out of state for petroleum, more in-state jobs, and cleaner air.

Specifically, I recommend that DEQ allocate the maximum allowable amount (15%) of the funds for electric vehicle charging infrastructure and installations. And I encourage DEQ to prioritize electric vehicles and buses for replacement whenever possible with the other 85% of the settlement funds. Doing so will maximize the local economic impact and the reduction of air pollution.

I encourage you to not use the funding for natural gas, propane or diesel vehicles. Further dependence on fossil fuels means more pollution. Only a transition to electric vehicles and investment in EV infrastructure will put us on the road to a 100% clean transportation sector in North Carolina.

Sincerely,

Gloria Shirley
105 Borden Avenue
Wilmington, NC 28403
gloriaann922@yahoo.com
(910) 616-1222

This message was sent by KnowWho, as a service provider only, on behalf of the individual noted in the sender information.

From: Susan Levitt (susan.i.levitt@gmail.com) Sent You a Personal Message
To: [daq.NC_VWGrants](#)
Subject: [External] Use Volkswagen funds to electrify NC transportation
Date: Tuesday, December 05, 2017 4:28:58 PM

CAUTION: External email. Do not click links or open attachments unless verified. Send all suspicious email as an attachment to report.spam@nc.gov.

Dear Division of Air Quality,

I am writing to urge DEQ to wisely invest the \$92 million in Volkswagen settlement funds in electric vehicles and infrastructure. Taking advantage of these funds to jumpstart the electrification of North Carolina's transportation sector will mean less money sent out of state for petroleum, more in-state jobs, and cleaner air.

Specifically, I recommend that DEQ allocate the maximum allowable amount (15%) of the funds for electric vehicle charging infrastructure and installations. And I encourage DEQ to prioritize electric vehicles and buses for replacement whenever possible with the other 85% of the settlement funds. Doing so will maximize the local economic impact and the reduction of air pollution.

I encourage you to not use the funding for natural gas, propane or diesel vehicles. Further dependence on fossil fuels means more pollution. Only a transition to electric vehicles and investment in EV infrastructure will put us on the road to a 100% clean transportation sector in North Carolina.

Sincerely,

Susan Levitt
5020 fox hollow dr
denver, NC 28037
susan.i.levitt@gmail.com
(704) 798-2231

This message was sent by KnowWho, as a service provider only, on behalf of the individual noted in the sender information.

From: keith johnson (kmjohnso15@hotmail.com) Sent You a Personal Message
To: [daq.NC_VWGrants](#)
Subject: [External] Use Volkswagen funds to electrify NC transportation
Date: Tuesday, December 05, 2017 4:28:51 PM

CAUTION: External email. Do not click links or open attachments unless verified. Send all suspicious email as an attachment to report.spam@nc.gov.

Dear Division of Air Quality,

I am writing to urge DEQ to wisely invest the \$92 million in Volkswagen settlement funds in electric vehicles and infrastructure. Taking advantage of these funds to jumpstart the electrification of North Carolina's transportation sector will mean less money sent out of state for petroleum, more in-state jobs, and cleaner air.

Specifically, I recommend that DEQ allocate the maximum allowable amount (15%) of the funds for electric vehicle charging infrastructure and installations. And I encourage DEQ to prioritize electric vehicles and buses for replacement whenever possible with the other 85% of the settlement funds. Doing so will maximize the local economic impact and the reduction of air pollution.

I encourage you to not use the funding for natural gas, propane or diesel vehicles. Further dependence on fossil fuels means more pollution. Only a transition to electric vehicles and investment in EV infrastructure will put us on the road to a 100% clean transportation sector in North Carolina.

Sincerely,

keith johnson
810 Buckner Springs Road
Siler City, NC 27344
kmjohnso15@hotmail.com
(919) 742-9953

This message was sent by KnowWho, as a service provider only, on behalf of the individual noted in the sender information.

From: Ronald Sigrist (ronaldsigrist@triad.rr.com) Sent You a Personal Message
To: [daq.NC_VWGrants](#)
Subject: [External] Use Volkswagen funds to electrify NC transportation
Date: Tuesday, December 05, 2017 4:28:50 PM

CAUTION: External email. Do not click links or open attachments unless verified. Send all suspicious email as an attachment to report.spam@nc.gov.

Dear Division of Air Quality,

I am writing to urge DEQ to wisely invest the \$92 million in Volkswagen settlement funds in electric vehicles and infrastructure. Taking advantage of these funds to jumpstart the electrification of North Carolina's transportation sector will mean less money sent out of state for petroleum, more in-state jobs, and cleaner air.

Specifically, I recommend that DEQ allocate the maximum allowable amount (15%) of the funds for electric vehicle charging infrastructure and installations. And I encourage DEQ to prioritize electric vehicles and buses for replacement whenever possible with the other 85% of the settlement funds. Doing so will maximize the local economic impact and the reduction of air pollution.

I encourage you to not use the funding for natural gas, propane or diesel vehicles. Further dependence on fossil fuels means more pollution. Only a transition to electric vehicles and investment in EV infrastructure will put us on the road to a 100% clean transportation sector in North Carolina.

Sincerely,

Ronald Sigrist
4383 Creekr Ridge Lane
Kernersville, NC 27284
ronaldsigrist@triad.rr.com
(336) 996-1614

This message was sent by KnowWho, as a service provider only, on behalf of the individual noted in the sender information.

From: Abby Phelps (abby51@live.unc.edu) Sent You a Personal Message
To: [daq.NC_VWGrants](#)
Subject: [External] Use Volkswagen funds to electrify NC transportation
Date: Tuesday, December 05, 2017 4:28:49 PM

CAUTION: External email. Do not click links or open attachments unless verified. Send all suspicious email as an attachment to report.spam@nc.gov.

Dear Division of Air Quality,

I am writing to urge DEQ to wisely invest the \$92 million in Volkswagen settlement funds in electric vehicles and infrastructure. Taking advantage of these funds to jumpstart the electrification of North Carolina's transportation sector will mean less money sent out of state for petroleum, more in-state jobs, and cleaner air.

Specifically, I recommend that DEQ allocate the maximum allowable amount (15%) of the funds for electric vehicle charging infrastructure and installations. And I encourage DEQ to prioritize electric vehicles and buses for replacement whenever possible with the other 85% of the settlement funds. Doing so will maximize the local economic impact and the reduction of air pollution.

I encourage you to not use the funding for natural gas, propane or diesel vehicles. Further dependence on fossil fuels means more pollution. Only a transition to electric vehicles and investment in EV infrastructure will put us on the road to a 100% clean transportation sector in North Carolina.

Sincerely,

Abby Phelps
416 west Cameron avenue
Chapel hill, NC 27514
abby51@live.unc.edu
(910) 777-4706

This message was sent by KnowWho, as a service provider only, on behalf of the individual noted in the sender information.

From: Eric Schweitzer (spinweb1@yahoo.com) Sent You a Personal Message
To: [daq.NC_VWGrants](#)
Subject: [External] Use Volkswagen funds to electrify NC transportation
Date: Tuesday, December 05, 2017 4:28:40 PM

CAUTION: External email. Do not click links or open attachments unless verified. Send all suspicious email as an attachment to report.spam@nc.gov.

Dear Division of Air Quality,

I am writing to urge DEQ to wisely invest the \$92 million in Volkswagen settlement funds in electric vehicles and infrastructure. Taking advantage of these funds to jumpstart the electrification of North Carolina's transportation sector will mean less money sent out of state for petroleum, more in-state jobs, and cleaner air.

Specifically, I recommend that DEQ allocate the maximum allowable amount (15%) of the funds for electric vehicle charging infrastructure and installations. And I encourage DEQ to prioritize electric vehicles and buses for replacement whenever possible with the other 85% of the settlement funds. Doing so will maximize the local economic impact and the reduction of air pollution.

I encourage you to not use the funding for natural gas, propane or diesel vehicles. Further dependence on fossil fuels means more pollution. Only a transition to electric vehicles and investment in EV infrastructure will put us on the road to a 100% clean transportation sector in North Carolina.

Sincerely,

Eric Schweitzer
6019 Sentinel Dr
Raleigh, NC 27609
spinweb1@yahoo.com
(919) 872-6071

This message was sent by KnowWho, as a service provider only, on behalf of the individual noted in the sender information.

From: Veronica Jones (veroniquilt@icloud.com) Sent You a Personal Message
To: [daq.NC_VWGrants](#)
Subject: [External] Use Volkswagen funds to electrify NC transportation
Date: Tuesday, December 05, 2017 4:28:37 PM

CAUTION: External email. Do not click links or open attachments unless verified. Send all suspicious email as an attachment to report.spam@nc.gov.

Dear Division of Air Quality,

I am writing to urge DEQ to wisely invest the \$92 million in Volkswagen settlement funds in electric vehicles and infrastructure. Taking advantage of these funds to jumpstart the electrification of North Carolina's transportation sector will mean less money sent out of state for petroleum, more in-state jobs, and cleaner air.

Specifically, I recommend that DEQ allocate the maximum allowable amount (15%) of the funds for electric vehicle charging infrastructure and installations. And I encourage DEQ to prioritize electric vehicles and buses for replacement whenever possible with the other 85% of the settlement funds. Doing so will maximize the local economic impact and the reduction of air pollution.

I encourage you to not use the funding for natural gas, propane or diesel vehicles. Further dependence on fossil fuels means more pollution. Only a transition to electric vehicles and investment in EV infrastructure will put us on the road to a 100% clean transportation sector in North Carolina.

Sincerely,

Veronica Jones
87 Gibson Rd
Asheville, NC 28804
veroniquilt@icloud.com
(828) 686-3433

This message was sent by KnowWho, as a service provider only, on behalf of the individual noted in the sender information.

From: Jerome Mayes (jerrym475@yahoo.com) Sent You a Personal Message
To: [daq.NC_VWGrants](#)
Subject: [External] Use Volkswagen funds to electrify NC transportation
Date: Tuesday, December 05, 2017 4:28:36 PM

CAUTION: External email. Do not click links or open attachments unless verified. Send all suspicious email as an attachment to report.spam@nc.gov.

Dear Division of Air Quality,

I am writing to urge DEQ to wisely invest the \$92 million in Volkswagen settlement funds in electric vehicles and infrastructure. Taking advantage of these funds to jumpstart the electrification of North Carolina's transportation sector will mean less money sent out of state for petroleum, more in-state jobs, and cleaner air.

Specifically, I recommend that DEQ allocate the maximum allowable amount (15%) of the funds for electric vehicle charging infrastructure and installations. And I encourage DEQ to prioritize electric vehicles and buses for replacement whenever possible with the other 85% of the settlement funds. Doing so will maximize the local economic impact and the reduction of air pollution.

I encourage you to not use the funding for natural gas, propane or diesel vehicles. Further dependence on fossil fuels means more pollution. Only a transition to electric vehicles and investment in EV infrastructure will put us on the road to a 100% clean transportation sector in North Carolina.

Sincerely,

Jerome Mayes
1521 Bridford Parkway Apt. 9M
Greensboro, NC 27407
jerrym475@yahoo.com
(704) 975-2482

This message was sent by KnowWho, as a service provider only, on behalf of the individual noted in the sender information.

From: Keith Bates (keithbatesnc@gmail.com) Sent You a Personal Message
To: [daq.NC_VWGrants](#)
Subject: [External] Use Volkswagen funds to electrify NC transportation
Date: Tuesday, December 05, 2017 4:28:32 PM

CAUTION: External email. Do not click links or open attachments unless verified. Send all suspicious email as an attachment to report.spam@nc.gov.

Dear Division of Air Quality,

I am writing to urge DEQ to wisely invest the \$92 million in Volkswagen settlement funds in electric vehicles and infrastructure. Taking advantage of these funds to jumpstart the electrification of North Carolina's transportation sector will mean less money sent out of state for petroleum, more in-state jobs, and cleaner air.

Specifically, I recommend that DEQ allocate the maximum allowable amount (15%) of the funds for electric vehicle charging infrastructure and installations. And I encourage DEQ to prioritize electric vehicles and buses for replacement whenever possible with the other 85% of the settlement funds. Doing so will maximize the local economic impact and the reduction of air pollution.

I encourage you to not use the funding for natural gas, propane or diesel vehicles. Further dependence on fossil fuels means more pollution. Only a transition to electric vehicles and investment in EV infrastructure will put us on the road to a 100% clean transportation sector in North Carolina.

Sincerely,

Keith Bates
212 Thomas Trail
Reidsville, NC 27320
keithbatesnc@gmail.com
(336) 791-4344

This message was sent by KnowWho, as a service provider only, on behalf of the individual noted in the sender information.

From: Hazel Poolos (hazel@poolos.com) Sent You a Personal Message
To: daq.NC_VWGrants
Subject: [External] Use Volkswagen funds to electrify NC transportation
Date: Tuesday, December 05, 2017 4:27:39 PM

CAUTION: External email. Do not click links or open attachments unless verified. Send all suspicious email as an attachment to report.spam@nc.gov.

Dear Division of Air Quality,

I am writing to urge DEQ to wisely invest the \$92 million in Volkswagen settlement funds in electric vehicles and infrastructure. Taking advantage of these funds to jumpstart the electrification of North Carolina's transportation sector will mean less money sent out of state for petroleum, more in-state jobs, and cleaner air.

Specifically, I recommend that DEQ allocate the maximum allowable amount (15%) of the funds for electric vehicle charging infrastructure and installations. And I encourage DEQ to prioritize electric vehicles and buses for replacement whenever possible with the other 85% of the settlement funds. Doing so will maximize the local economic impact and the reduction of air pollution.

I encourage you to not use the funding for natural gas, propane or diesel vehicles. Further dependence on fossil fuels means more pollution. Only a transition to electric vehicles and investment in EV infrastructure will put us on the road to a 100% clean transportation sector in North Carolina.

Sincerely,

Hazel Poolos
42717 Caudle Rd
Richfield, NC 28137
hazel@poolos.com
(704) 463-5725

This message was sent by KnowWho, as a service provider only, on behalf of the individual noted in the sender information.

From: Adam Leman (adam.leman@gmail.com) Sent You a Personal Message
To: [daq.NC_VWGrants](#)
Subject: [External] Use Volkswagen funds to electrify NC transportation
Date: Tuesday, December 05, 2017 4:27:12 PM

CAUTION: External email. Do not click links or open attachments unless verified. Send all suspicious email as an attachment to report.spam@nc.gov.

Dear Division of Air Quality,

I am writing to urge DEQ to wisely invest the \$92 million in Volkswagen settlement funds in electric vehicles and infrastructure. Taking advantage of these funds to jumpstart the electrification of North Carolina's transportation sector will mean less money sent out of state for petroleum, more in-state jobs, and cleaner air.

Specifically, I recommend that DEQ allocate the maximum allowable amount (15%) of the funds for electric vehicle charging infrastructure and installations. And I encourage DEQ to prioritize electric vehicles and buses for replacement whenever possible with the other 85% of the settlement funds. Doing so will maximize the local economic impact and the reduction of air pollution.

I encourage you to not use the funding for natural gas, propane or diesel vehicles. Further dependence on fossil fuels means more pollution. Only a transition to electric vehicles and investment in EV infrastructure will put us on the road to a 100% clean transportation sector in North Carolina.

Sincerely,

Adam Leman
102 Yorktown Dr.
Chapel Hill, NC 27516
adam.leman@gmail.com
(716) 474-7464

This message was sent by KnowWho, as a service provider only, on behalf of the individual noted in the sender information.

From: Robert Belknap (rebelknap@sms.edu) Sent You a Personal Message
To: [daq.NC_VWGrants](#)
Subject: [External] Use Volkswagen funds to electrify NC transportation
Date: Tuesday, December 05, 2017 4:27:11 PM

CAUTION: External email. Do not click links or open attachments unless verified. Send all suspicious email as an attachment to report.spam@nc.gov.

Dear Division of Air Quality,

I am writing to urge DEQ to wisely invest the \$92 million in Volkswagen settlement funds in electric vehicles and infrastructure. Taking advantage of these funds to jumpstart the electrification of North Carolina's transportation sector will mean less money sent out of state for petroleum, more in-state jobs, and cleaner air.

Specifically, I recommend that DEQ allocate the maximum allowable amount (15%) of the funds for electric vehicle charging infrastructure and installations. And I encourage DEQ to prioritize electric vehicles and buses for replacement whenever possible with the other 85% of the settlement funds. Doing so will maximize the local economic impact and the reduction of air pollution.

I encourage you to not use the funding for natural gas, propane or diesel vehicles. Further dependence on fossil fuels means more pollution. Only a transition to electric vehicles and investment in EV infrastructure will put us on the road to a 100% clean transportation sector in North Carolina.

Sincerely,

Robert Belknap
900 Hillsborough Street
Raleigh, NC 27603
rebelknap@sms.edu
(919) 424-3654

This message was sent by KnowWho, as a service provider only, on behalf of the individual noted in the sender information.

From: James Bengel (jbengel@brandenburg3.com) Sent You a Personal Message
To: [daq.NC_VWGrants](#)
Subject: [External] Use Volkswagen funds to electrify NC transportation
Date: Tuesday, December 05, 2017 4:26:59 PM

CAUTION: External email. Do not click links or open attachments unless verified. Send all suspicious email as an attachment to report.spam@nc.gov.

Dear Division of Air Quality,

I am writing to urge DEQ to wisely invest the \$92 million in Volkswagen settlement funds in electric vehicles and infrastructure. Taking advantage of these funds to jumpstart the electrification of North Carolina's transportation sector will mean less money sent out of state for petroleum, more in-state jobs, and cleaner air.

Specifically, I recommend that DEQ allocate the maximum allowable amount (15%) of the funds for electric vehicle charging infrastructure and installations. And I encourage DEQ to prioritize electric vehicles and buses for replacement whenever possible with the other 85% of the settlement funds. Doing so will maximize the local economic impact and the reduction of air pollution.

I encourage you to not use the funding for natural gas, propane or diesel vehicles. Further dependence on fossil fuels means more pollution. Only a transition to electric vehicles and investment in EV infrastructure will put us on the road to a 100% clean transportation sector in North Carolina.

Sincerely,

James Bengel
20 Canterbury Ct
Wendell, NC 27591
jbengel@brandenburg3.com
(919) 782-2247

This message was sent by KnowWho, as a service provider only, on behalf of the individual noted in the sender information.

From: christopher riegert (chrisriegert@gmail.com) Sent You a Personal Message
To: [daq.NC_VWGrants](#)
Subject: [External] Use Volkswagen funds to electrify NC transportation
Date: Tuesday, December 05, 2017 4:26:49 PM

CAUTION: External email. Do not click links or open attachments unless verified. Send all suspicious email as an attachment to report.spam@nc.gov.

Dear Division of Air Quality,

I am writing to urge DEQ to wisely invest the \$92 million in Volkswagen settlement funds in electric vehicles and infrastructure. Taking advantage of these funds to jumpstart the electrification of North Carolina's transportation sector will mean less money sent out of state for petroleum, more in-state jobs, and cleaner air.

Specifically, I recommend that DEQ allocate the maximum allowable amount (15%) of the funds for electric vehicle charging infrastructure and installations. And I encourage DEQ to prioritize electric vehicles and buses for replacement whenever possible with the other 85% of the settlement funds. Doing so will maximize the local economic impact and the reduction of air pollution.

I encourage you to not use the funding for natural gas, propane or diesel vehicles. Further dependence on fossil fuels means more pollution. Only a transition to electric vehicles and investment in EV infrastructure will put us on the road to a 100% clean transportation sector in North Carolina.

Sincerely,

christopher riegert
2222 East Pelican Dr
Oak Island, NC 28465
chrisriegert@gmail.com
(540) 808-3358

This message was sent by KnowWho, as a service provider only, on behalf of the individual noted in the sender information.

From: Crawford Horne (crawfordjhorne@gmail.com) Sent You a Personal Message
To: [daq.NC_VWGrants](#)
Subject: [External] Use Volkswagen funds to electrify NC transportation
Date: Tuesday, December 05, 2017 4:26:48 PM

CAUTION: External email. Do not click links or open attachments unless verified. Send all suspicious email as an attachment to report.spam@nc.gov.

Dear Division of Air Quality,

I am writing to urge DEQ to wisely invest the \$92 million in Volkswagen settlement funds in electric vehicles and infrastructure. Taking advantage of these funds to jumpstart the electrification of North Carolina's transportation sector will mean less money sent out of state for petroleum, more in-state jobs, and cleaner air.

Specifically, I recommend that DEQ allocate the maximum allowable amount (15%) of the funds for electric vehicle charging infrastructure and installations. And I encourage DEQ to prioritize electric vehicles and buses for replacement whenever possible with the other 85% of the settlement funds. Doing so will maximize the local economic impact and the reduction of air pollution.

I encourage you to not use the funding for natural gas, propane or diesel vehicles. Further dependence on fossil fuels means more pollution. Only a transition to electric vehicles and investment in EV infrastructure will put us on the road to a 100% clean transportation sector in North Carolina.

Sincerely,

Crawford Horne
813 Lawrence Road
Hillsborough, NC 27278
crawfordjhorne@gmail.com
(919) 245-8077

This message was sent by KnowWho, as a service provider only, on behalf of the individual noted in the sender information.

From: Margaret Sands (mosands7@gmail.com) Sent You a Personal Message
To: [daq.NC_VWGrants](#)
Subject: [External] Use Volkswagen funds to electrify NC transportation
Date: Tuesday, December 05, 2017 4:26:47 PM

CAUTION: External email. Do not click links or open attachments unless verified. Send all suspicious email as an attachment to report.spam@nc.gov.

Dear Division of Air Quality,

I am writing to urge DEQ to wisely invest the \$92 million in Volkswagen settlement funds in electric vehicles and infrastructure. Taking advantage of these funds to jumpstart the electrification of North Carolina's transportation sector will mean less money sent out of state for petroleum, more in-state jobs, and cleaner air.

Specifically, I recommend that DEQ allocate the maximum allowable amount (15%) of the funds for electric vehicle charging infrastructure and installations. And I encourage DEQ to prioritize electric vehicles and buses for replacement whenever possible with the other 85% of the settlement funds. Doing so will maximize the local economic impact and the reduction of air pollution.

I encourage you to not use the funding for natural gas, propane or diesel vehicles. Further dependence on fossil fuels means more pollution. Only a transition to electric vehicles and investment in EV infrastructure will put us on the road to a 100% clean transportation sector in North Carolina.

Sincerely,

Margaret Sands
510 Watts St Apt 4
Durham, NC 27701
mosands7@gmail.com
(843) 907-2935

This message was sent by KnowWho, as a service provider only, on behalf of the individual noted in the sender information.

From: bonnie cooper (bonniecooperphotography@yahoo.com) Sent You a Personal Message
To: [daq.NC_VWGrants](#)
Subject: [External] Use Volkswagen funds to electrify NC transportation
Date: Tuesday, December 05, 2017 4:26:44 PM

CAUTION: External email. Do not click links or open attachments unless verified. Send all suspicious email as an attachment to report.spam@nc.gov.

Dear Division of Air Quality,

I am writing to urge DEQ to wisely invest the \$92 million in Volkswagen settlement funds in electric vehicles and infrastructure. Taking advantage of these funds to jumpstart the electrification of North Carolina's transportation sector will mean less money sent out of state for petroleum, more in-state jobs, and cleaner air.

Specifically, I recommend that DEQ allocate the maximum allowable amount (15%) of the funds for electric vehicle charging infrastructure and installations. And I encourage DEQ to prioritize electric vehicles and buses for replacement whenever possible with the other 85% of the settlement funds. Doing so will maximize the local economic impact and the reduction of air pollution.

I encourage you to not use the funding for natural gas, propane or diesel vehicles. Further dependence on fossil fuels means more pollution. Only a transition to electric vehicles and investment in EV infrastructure will put us on the road to a 100% clean transportation sector in North Carolina.

Sincerely,

bonnie cooper
po box 6383
asheville, NC 28816
bonniecooperphotography@yahoo.com
(828) 788-5142

This message was sent by KnowWho, as a service provider only, on behalf of the individual noted in the sender information.

From: Arliss Whiteside (arlissmarion@juno.com) Sent You a Personal Message
To: [daq.NC_VWGrants](#)
Subject: [External] Use Volkswagen funds to electrify NC transportation
Date: Tuesday, December 05, 2017 4:26:18 PM

CAUTION: External email. Do not click links or open attachments unless verified. Send all suspicious email as an attachment to report.spam@nc.gov.

Dear Division of Air Quality,

I am writing to urge DEQ to wisely invest the \$92 million in Volkswagen settlement funds in electric vehicles and infrastructure. Taking advantage of these funds to jumpstart the electrification of North Carolina's transportation sector will mean less money sent out of state for petroleum, more in-state jobs, and cleaner air.

Specifically, I recommend that DEQ allocate the maximum allowable amount (15%) of the funds for electric vehicle charging infrastructure and installations. And I encourage DEQ to prioritize electric vehicles and buses for replacement whenever possible with the other 85% of the settlement funds. Doing so will maximize the local economic impact and the reduction of air pollution.

I encourage you to not use the funding for natural gas, propane or diesel vehicles. Further dependence on fossil fuels means more pollution. Only a transition to electric vehicles and investment in EV infrastructure will put us on the road to a 100% clean transportation sector in North Carolina.

Sincerely,

Arliss Whiteside
8919 Park Road Apt 219
Charlotte, NC 28210
arlissmarion@juno.com
(704) 551-6919

This message was sent by KnowWho, as a service provider only, on behalf of the individual noted in the sender information.

From: Susan Jacquet (sjacquet@berkeley.edu) Sent You a Personal Message
To: [daq.NC_VWGrants](#)
Subject: [External] Use Volkswagen funds to electrify NC transportation
Date: Tuesday, December 05, 2017 4:26:17 PM

CAUTION: External email. Do not click links or open attachments unless verified. Send all suspicious email as an attachment to report.spam@nc.gov.

Dear Division of Air Quality,

I am writing to urge DEQ to wisely invest the \$92 million in Volkswagen settlement funds in electric vehicles and infrastructure. Taking advantage of these funds to jumpstart the electrification of North Carolina's transportation sector will mean less money sent out of state for petroleum, more in-state jobs, and cleaner air.

Specifically, I recommend that DEQ allocate the maximum allowable amount (15%) of the funds for electric vehicle charging infrastructure and installations. And I encourage DEQ to prioritize electric vehicles and buses for replacement whenever possible with the other 85% of the settlement funds. Doing so will maximize the local economic impact and the reduction of air pollution.

I encourage you to not use the funding for natural gas, propane or diesel vehicles. Further dependence on fossil fuels means more pollution. Only a transition to electric vehicles and investment in EV infrastructure will put us on the road to a 100% clean transportation sector in North Carolina.

Sincerely,

Susan Jacquet
38 Tahkieostie Trl
Asheville, NC 28806
sjacquet@berkeley.edu
(828) 505-7888

This message was sent by KnowWho, as a service provider only, on behalf of the individual noted in the sender information.

From: Sarah Reincke (sarahreinck@gmail.com) Sent You a Personal Message
To: [daq.NC_VWGrants](#)
Subject: [External] Use Volkswagen funds to electrify NC transportation
Date: Tuesday, December 05, 2017 4:26:16 PM

CAUTION: External email. Do not click links or open attachments unless verified. Send all suspicious email as an attachment to report.spam@nc.gov.

Dear Division of Air Quality,

I am writing to urge DEQ to wisely invest the \$92 million in Volkswagen settlement funds in electric vehicles and infrastructure. Taking advantage of these funds to jumpstart the electrification of North Carolina's transportation sector will mean less money sent out of state for petroleum, more in-state jobs, and cleaner air.

Specifically, I recommend that DEQ allocate the maximum allowable amount (15%) of the funds for electric vehicle charging infrastructure and installations. And I encourage DEQ to prioritize electric vehicles and buses for replacement whenever possible with the other 85% of the settlement funds. Doing so will maximize the local economic impact and the reduction of air pollution.

I encourage you to not use the funding for natural gas, propane or diesel vehicles. Further dependence on fossil fuels means more pollution. Only a transition to electric vehicles and investment in EV infrastructure will put us on the road to a 100% clean transportation sector in North Carolina.

Sincerely,

Sarah Reincke
750 bear left
Asheville, NC 28805
sarahreinck@gmail.com
(828) 350-7964

This message was sent by KnowWho, as a service provider only, on behalf of the individual noted in the sender information.

From: Gihon Glenn (gihonglenn@yahoo.com) Sent You a Personal Message
To: [daq.NC_VWGrants](#)
Subject: [External] Use Volkswagen funds to electrify NC transportation
Date: Tuesday, December 05, 2017 4:26:15 PM

CAUTION: External email. Do not click links or open attachments unless verified. Send all suspicious email as an attachment to report.spam@nc.gov.

Dear Division of Air Quality,

I am writing to urge DEQ to wisely invest the \$92 million in Volkswagen settlement funds in electric vehicles and infrastructure. Taking advantage of these funds to jumpstart the electrification of North Carolina's transportation sector will mean less money sent out of state for petroleum, more in-state jobs, and cleaner air.

Specifically, I recommend that DEQ allocate the maximum allowable amount (15%) of the funds for electric vehicle charging infrastructure and installations. And I encourage DEQ to prioritize electric vehicles and buses for replacement whenever possible with the other 85% of the settlement funds. Doing so will maximize the local economic impact and the reduction of air pollution.

I encourage you to not use the funding for natural gas, propane or diesel vehicles. Further dependence on fossil fuels means more pollution. Only a transition to electric vehicles and investment in EV infrastructure will put us on the road to a 100% clean transportation sector in North Carolina.

Sincerely,

Gihon Glenn
1934 Clark road
Robersonville, NC 27871
gihonglenn@yahoo.com
(252) 217-4431

This message was sent by KnowWho, as a service provider only, on behalf of the individual noted in the sender information.

From: Carolyn Hess (cmhrah@mediacombb.net) Sent You a Personal Message
To: [daq.NC_VWGrants](#)
Subject: [External] Use Volkswagen funds to electrify NC transportation
Date: Tuesday, December 05, 2017 4:26:14 PM

CAUTION: External email. Do not click links or open attachments unless verified. Send all suspicious email as an attachment to report.spam@nc.gov.

Dear Division of Air Quality,

I am writing to urge DEQ to wisely invest the \$92 million in Volkswagen settlement funds in electric vehicles and infrastructure. Taking advantage of these funds to jumpstart the electrification of North Carolina's transportation sector will mean less money sent out of state for petroleum, more in-state jobs, and cleaner air.

Specifically, I recommend that DEQ allocate the maximum allowable amount (15%) of the funds for electric vehicle charging infrastructure and installations. And I encourage DEQ to prioritize electric vehicles and buses for replacement whenever possible with the other 85% of the settlement funds. Doing so will maximize the local economic impact and the reduction of air pollution.

I encourage you to not use the funding for natural gas, propane or diesel vehicles. Further dependence on fossil fuels means more pollution. Only a transition to electric vehicles and investment in EV infrastructure will put us on the road to a 100% clean transportation sector in North Carolina.

Sincerely,

Carolyn Hess
140 Sunset Circle
Hertford, NC 27944
cmhrah@mediacombb.net
(252) 426-9563

This message was sent by KnowWho, as a service provider only, on behalf of the individual noted in the sender information.

From: Jill Heishman (heishman.jill@gmail.com) Sent You a Personal Message
To: [daq.NC_VWGrants](#)
Subject: [External] Use Volkswagen funds to electrify NC transportation
Date: Tuesday, December 05, 2017 4:26:12 PM

CAUTION: External email. Do not click links or open attachments unless verified. Send all suspicious email as an attachment to report.spam@nc.gov.

Dear Division of Air Quality,

I am writing to urge DEQ to wisely invest the \$92 million in Volkswagen settlement funds in electric vehicles and infrastructure. Taking advantage of these funds to jumpstart the electrification of North Carolina's transportation sector will mean less money sent out of state for petroleum, more in-state jobs, and cleaner air.

Specifically, I recommend that DEQ allocate the maximum allowable amount (15%) of the funds for electric vehicle charging infrastructure and installations. And I encourage DEQ to prioritize electric vehicles and buses for replacement whenever possible with the other 85% of the settlement funds. Doing so will maximize the local economic impact and the reduction of air pollution.

I encourage you to not use the funding for natural gas, propane or diesel vehicles. Further dependence on fossil fuels means more pollution. Only a transition to electric vehicles and investment in EV infrastructure will put us on the road to a 100% clean transportation sector in North Carolina.

Sincerely,

Jill Heishman
148 MURDOCK AVE
ASHEVILLE, NC 28801
heishman.jill@gmail.com
(828) 242-2072

This message was sent by KnowWho, as a service provider only, on behalf of the individual noted in the sender information.

From: Robert Petty (rob@surforsound.com) Sent You a Personal Message
To: [daq.NC_VWGrants](#)
Subject: [External] Use Volkswagen funds to electrify NC transportation
Date: Tuesday, December 05, 2017 4:25:55 PM

CAUTION: External email. Do not click links or open attachments unless verified. Send all suspicious email as an attachment to report.spam@nc.gov.

Dear Division of Air Quality,

I am writing to urge DEQ to wisely invest the \$92 million in Volkswagen settlement funds in electric vehicles and infrastructure. Taking advantage of these funds to jumpstart the electrification of North Carolina's transportation sector will mean less money sent out of state for petroleum, more in-state jobs, and cleaner air.

Specifically, I recommend that DEQ allocate the maximum allowable amount (15%) of the funds for electric vehicle charging infrastructure and installations. And I encourage DEQ to prioritize electric vehicles and buses for replacement whenever possible with the other 85% of the settlement funds. Doing so will maximize the local economic impact and the reduction of air pollution.

I encourage you to not use the funding for natural gas, propane or diesel vehicles. Further dependence on fossil fuels means more pollution. Only a transition to electric vehicles and investment in EV infrastructure will put us on the road to a 100% clean transportation sector in North Carolina.

Sincerely,

Robert Petty
2617 S. Compass Lane
Nags Head, NC 27959
rob@surforsound.com
(252) 256-2830

This message was sent by KnowWho, as a service provider only, on behalf of the individual noted in the sender information.

From: Taina Diaz-Reyes (diaztm16@wfu.edu) Sent You a Personal Message
To: daq.NC_VWGrants
Subject: [External] Use Volkswagen funds to electrify NC transportation
Date: Tuesday, December 05, 2017 4:25:36 PM

CAUTION: External email. Do not click links or open attachments unless verified. Send all suspicious email as an attachment to report.spam@nc.gov.

Dear Division of Air Quality,

I am writing to urge DEQ to wisely invest the \$92 million in Volkswagen settlement funds in electric vehicles and infrastructure. Taking advantage of these funds to jumpstart the electrification of North Carolina's transportation sector will mean less money sent out of state for petroleum, more in-state jobs, and cleaner air.

Specifically, I recommend that DEQ allocate the maximum allowable amount (15%) of the funds for electric vehicle charging infrastructure and installations. And I encourage DEQ to prioritize electric vehicles and buses for replacement whenever possible with the other 85% of the settlement funds. Doing so will maximize the local economic impact and the reduction of air pollution.

I encourage you to not use the funding for natural gas, propane or diesel vehicles. Further dependence on fossil fuels means more pollution. Only a transition to electric vehicles and investment in EV infrastructure will put us on the road to a 100% clean transportation sector in North Carolina.

Sincerely,

Taina Diaz-Reyes
2700 Reynolda Rd, Apt 610
Winston Salem, NC 27106
diaztm16@wfu.edu
(301) 448-6349

This message was sent by KnowWho, as a service provider only, on behalf of the individual noted in the sender information.

From: William Larson (larson266@aol.com) Sent You a Personal Message
To: [daq.NC_VWGrants](#)
Subject: [External] Use Volkswagen funds to electrify NC transportation
Date: Tuesday, December 05, 2017 4:25:16 PM

CAUTION: External email. Do not click links or open attachments unless verified. Send all suspicious email as an attachment to report.spam@nc.gov.

Dear Division of Air Quality,

I am writing to urge DEQ to wisely invest the \$92 million in Volkswagen settlement funds in electric vehicles and infrastructure. Taking advantage of these funds to jumpstart the electrification of North Carolina's transportation sector will mean less money sent out of state for petroleum, more in-state jobs, and cleaner air.

Specifically, I recommend that DEQ allocate the maximum allowable amount (15%) of the funds for electric vehicle charging infrastructure and installations. And I encourage DEQ to prioritize electric vehicles and buses for replacement whenever possible with the other 85% of the settlement funds. Doing so will maximize the local economic impact and the reduction of air pollution.

I encourage you to not use the funding for natural gas, propane or diesel vehicles. Further dependence on fossil fuels means more pollution. Only a transition to electric vehicles and investment in EV infrastructure will put us on the road to a 100% clean transportation sector in North Carolina.

Sincerely,

William Larson
304A N Hillcrest Dr
Goldsboro, NC 27534
larson266@aol.com
(919) 288-1852

This message was sent by KnowWho, as a service provider only, on behalf of the individual noted in the sender information.

From: John Fedorczyk (fedorczyknc@gmail.com) Sent You a Personal Message
To: [daq.NC_VWGrants](#)
Subject: [External] Use Volkswagen funds to electrify NC transportation
Date: Tuesday, December 05, 2017 4:25:06 PM

CAUTION: External email. Do not click links or open attachments unless verified. Send all suspicious email as an attachment to report.spam@nc.gov.

Dear Division of Air Quality,

I am writing to urge DEQ to wisely invest the \$92 million in Volkswagen settlement funds in electric vehicles and infrastructure. Taking advantage of these funds to jumpstart the electrification of North Carolina's transportation sector will mean less money sent out of state for petroleum, more in-state jobs, and cleaner air.

Specifically, I recommend that DEQ allocate the maximum allowable amount (15%) of the funds for electric vehicle charging infrastructure and installations. And I encourage DEQ to prioritize electric vehicles and buses for replacement whenever possible with the other 85% of the settlement funds. Doing so will maximize the local economic impact and the reduction of air pollution.

I encourage you to not use the funding for natural gas, propane or diesel vehicles. Further dependence on fossil fuels means more pollution. Only a transition to electric vehicles and investment in EV infrastructure will put us on the road to a 100% clean transportation sector in North Carolina.

Sincerely,

John Fedorczyk
3669 Burton Street
Sherrills Ford, NC 28673
fedorczyknc@gmail.com
(828) 478-1006

This message was sent by KnowWho, as a service provider only, on behalf of the individual noted in the sender information.

From: Theresa Klose (klosets@gmail.com) Sent You a Personal Message
To: [daq.NC_VWGrants](#)
Subject: [External] Use Volkswagen funds to electrify NC transportation
Date: Tuesday, December 05, 2017 4:24:56 PM

CAUTION: External email. Do not click links or open attachments unless verified. Send all suspicious email as an attachment to report.spam@nc.gov.

Dear Division of Air Quality,

I am writing to urge DEQ to wisely invest the \$92 million in Volkswagen settlement funds in electric vehicles and infrastructure. Taking advantage of these funds to jumpstart the electrification of North Carolina's transportation sector will mean less money sent out of state for petroleum, more in-state jobs, and cleaner air.

Specifically, I recommend that DEQ allocate the maximum allowable amount (15%) of the funds for electric vehicle charging infrastructure and installations. And I encourage DEQ to prioritize electric vehicles and buses for replacement whenever possible with the other 85% of the settlement funds. Doing so will maximize the local economic impact and the reduction of air pollution.

I encourage you to not use the funding for natural gas, propane or diesel vehicles. Further dependence on fossil fuels means more pollution. Only a transition to electric vehicles and investment in EV infrastructure will put us on the road to a 100% clean transportation sector in North Carolina.

Sincerely,

Theresa Klose
2713 Weaver Hill Drive
Theresa, NC 27502
klosets@gmail.com
(919) 757-4378

This message was sent by KnowWho, as a service provider only, on behalf of the individual noted in the sender information.

From: Jeff Jelinek (jjellyneck@yahoo.com) Sent You a Personal Message
To: [daq.NC_VWGrants](#)
Subject: [External] Use Volkswagen funds to electrify NC transportation
Date: Tuesday, December 05, 2017 4:24:55 PM

CAUTION: External email. Do not click links or open attachments unless verified. Send all suspicious email as an attachment to report.spam@nc.gov.

Dear Division of Air Quality,

I am writing to urge DEQ to wisely invest the \$92 million in Volkswagen settlement funds in electric vehicles and infrastructure. Taking advantage of these funds to jumpstart the electrification of North Carolina's transportation sector will mean less money sent out of state for petroleum, more in-state jobs, and cleaner air.

Specifically, I recommend that DEQ allocate the maximum allowable amount (15%) of the funds for electric vehicle charging infrastructure and installations. And I encourage DEQ to prioritize electric vehicles and buses for replacement whenever possible with the other 85% of the settlement funds. Doing so will maximize the local economic impact and the reduction of air pollution.

I encourage you to not use the funding for natural gas, propane or diesel vehicles. Further dependence on fossil fuels means more pollution. Only a transition to electric vehicles and investment in EV infrastructure will put us on the road to a 100% clean transportation sector in North Carolina.

Sincerely,

Jeff Jelinek
1209 Retreat Hill Way
Asheville, NC 28801
jjellyneck@yahoo.com
(828) 747-0400

This message was sent by KnowWho, as a service provider only, on behalf of the individual noted in the sender information.

From: Cali Reed (calimreed@gmail.com) Sent You a Personal Message
To: [daq.NC_VWGrants](#)
Subject: [External] Use Volkswagen funds to electrify NC transportation
Date: Tuesday, December 05, 2017 4:24:55 PM

CAUTION: External email. Do not click links or open attachments unless verified. Send all suspicious email as an attachment to report.spam@nc.gov.

Dear Division of Air Quality,

I am writing to urge DEQ to wisely invest the \$92 million in Volkswagen settlement funds in electric vehicles and infrastructure. Taking advantage of these funds to jumpstart the electrification of North Carolina's transportation sector will mean less money sent out of state for petroleum, more in-state jobs, and cleaner air.

Specifically, I recommend that DEQ allocate the maximum allowable amount (15%) of the funds for electric vehicle charging infrastructure and installations. And I encourage DEQ to prioritize electric vehicles and buses for replacement whenever possible with the other 85% of the settlement funds. Doing so will maximize the local economic impact and the reduction of air pollution.

I encourage you to not use the funding for natural gas, propane or diesel vehicles. Further dependence on fossil fuels means more pollution. Only a transition to electric vehicles and investment in EV infrastructure will put us on the road to a 100% clean transportation sector in North Carolina.

Sincerely,

Cali Reed
219 Brevard Road
Asheville, NC 28806
calimreed@gmail.com
(209) 918-0962

This message was sent by KnowWho, as a service provider only, on behalf of the individual noted in the sender information.

From: James Thomas (jmichaelthomas2001@yahoo.com) Sent You a Personal Message
To: [daq.NC_VWGrants](#)
Subject: [External] Use Volkswagen funds to electrify NC transportation
Date: Tuesday, December 05, 2017 4:24:47 PM

CAUTION: External email. Do not click links or open attachments unless verified. Send all suspicious email as an attachment to report.spam@nc.gov.

Dear Division of Air Quality,

I am writing to urge DEQ to wisely invest the \$92 million in Volkswagen settlement funds in electric vehicles and infrastructure. Taking advantage of these funds to jumpstart the electrification of North Carolina's transportation sector will mean less money sent out of state for petroleum, more in-state jobs, and cleaner air.

Specifically, I recommend that DEQ allocate the maximum allowable amount (15%) of the funds for electric vehicle charging infrastructure and installations. And I encourage DEQ to prioritize electric vehicles and buses for replacement whenever possible with the other 85% of the settlement funds. Doing so will maximize the local economic impact and the reduction of air pollution.

I encourage you to not use the funding for natural gas, propane or diesel vehicles. Further dependence on fossil fuels means more pollution. Only a transition to electric vehicles and investment in EV infrastructure will put us on the road to a 100% clean transportation sector in North Carolina.

Sincerely,

James Thomas
5900 Hathaway Lane
Chapel Hill, NC 27514
jmichaelthomas2001@yahoo.com
(919) 668-9050

This message was sent by KnowWho, as a service provider only, on behalf of the individual noted in the sender information.

From: Jennifer Kain (bskain@ameritech.net) Sent You a Personal Message
To: [daq.NC_VWGrants](#)
Subject: [External] Use Volkswagen funds to electrify NC transportation
Date: Tuesday, December 05, 2017 4:23:55 PM

CAUTION: External email. Do not click links or open attachments unless verified. Send all suspicious email as an attachment to report.spam@nc.gov.

Dear Division of Air Quality,

I am writing to urge DEQ to wisely invest the \$92 million in Volkswagen settlement funds in electric vehicles and infrastructure. Taking advantage of these funds to jumpstart the electrification of North Carolina's transportation sector will mean less money sent out of state for petroleum, more in-state jobs, and cleaner air.

Specifically, I recommend that DEQ allocate the maximum allowable amount (15%) of the funds for electric vehicle charging infrastructure and installations. And I encourage DEQ to prioritize electric vehicles and buses for replacement whenever possible with the other 85% of the settlement funds. Doing so will maximize the local economic impact and the reduction of air pollution.

I encourage you to not use the funding for natural gas, propane or diesel vehicles. Further dependence on fossil fuels means more pollution. Only a transition to electric vehicles and investment in EV infrastructure will put us on the road to a 100% clean transportation sector in North Carolina.

Sincerely,

Jennifer Kain
264 Oxfordshire Drive
Fuquay-Varina, NC 27526
bskain@ameritech.net
(317) 840-5415

This message was sent by KnowWho, as a service provider only, on behalf of the individual noted in the sender information.

From: Eileen McCorry (mccorrye@gmail.com) Sent You a Personal Message
To: daq.NC_VWGrants
Subject: [External] Use Volkswagen funds to electrify NC transportation
Date: Tuesday, December 05, 2017 4:23:48 PM

CAUTION: External email. Do not click links or open attachments unless verified. Send all suspicious email as an attachment to report.spam@nc.gov.

Dear Division of Air Quality,

I am writing to urge DEQ to wisely invest the \$92 million in Volkswagen settlement funds in electric vehicles and infrastructure. Taking advantage of these funds to jumpstart the electrification of North Carolina's transportation sector will mean less money sent out of state for petroleum, more in-state jobs, and cleaner air.

Specifically, I recommend that DEQ allocate the maximum allowable amount (15%) of the funds for electric vehicle charging infrastructure and installations. And I encourage DEQ to prioritize electric vehicles and buses for replacement whenever possible with the other 85% of the settlement funds. Doing so will maximize the local economic impact and the reduction of air pollution.

I encourage you to not use the funding for natural gas, propane or diesel vehicles. Further dependence on fossil fuels means more pollution. Only a transition to electric vehicles and investment in EV infrastructure will put us on the road to a 100% clean transportation sector in North Carolina.

Sincerely,

Eileen McCorry
4103 Fearington Post
Pittsboro, NC 27312
mccorrye@gmail.com
(919) 533-6821

This message was sent by KnowWho, as a service provider only, on behalf of the individual noted in the sender information.

From: Edgar Lind (allan.lind@duke.edu) Sent You a Personal Message
To: [daq.NC_VWGrants](#)
Subject: [External] Use Volkswagen funds to electrify NC transportation
Date: Tuesday, December 05, 2017 4:23:47 PM

CAUTION: External email. Do not click links or open attachments unless verified. Send all suspicious email as an attachment to report.spam@nc.gov.

Dear Division of Air Quality,

I am writing to urge DEQ to wisely invest the \$92 million in Volkswagen settlement funds in electric vehicles and infrastructure. Taking advantage of these funds to jumpstart the electrification of North Carolina's transportation sector will mean less money sent out of state for petroleum, more in-state jobs, and cleaner air.

Specifically, I recommend that DEQ allocate the maximum allowable amount (15%) of the funds for electric vehicle charging infrastructure and installations. And I encourage DEQ to prioritize electric vehicles and buses for replacement whenever possible with the other 85% of the settlement funds. Doing so will maximize the local economic impact and the reduction of air pollution.

I encourage you to not use the funding for natural gas, propane or diesel vehicles. Further dependence on fossil fuels means more pollution. Only a transition to electric vehicles and investment in EV infrastructure will put us on the road to a 100% clean transportation sector in North Carolina.

Sincerely,

Edgar Lind
5813 Brisbane Drive
Chapel Hill, NC 27514
allan.lind@duke.edu
(919) 724-1130

This message was sent by KnowWho, as a service provider only, on behalf of the individual noted in the sender information.

From: Selena Lauterer (slauterer@gmail.com) Sent You a Personal Message
To: [daq.NC_VWGrants](#)
Subject: [External] Use Volkswagen funds to electrify NC transportation
Date: Tuesday, December 05, 2017 4:23:46 PM

CAUTION: External email. Do not click links or open attachments unless verified. Send all suspicious email as an attachment to report.spam@nc.gov.

Dear Division of Air Quality,

I am writing to urge DEQ to wisely invest the \$92 million in Volkswagen settlement funds in electric vehicles and infrastructure. Taking advantage of these funds to jumpstart the electrification of North Carolina's transportation sector will mean less money sent out of state for petroleum, more in-state jobs, and cleaner air.

Specifically, I recommend that DEQ allocate the maximum allowable amount (15%) of the funds for electric vehicle charging infrastructure and installations. And I encourage DEQ to prioritize electric vehicles and buses for replacement whenever possible with the other 85% of the settlement funds. Doing so will maximize the local economic impact and the reduction of air pollution.

I encourage you to not use the funding for natural gas, propane or diesel vehicles. Further dependence on fossil fuels means more pollution. Only a transition to electric vehicles and investment in EV infrastructure will put us on the road to a 100% clean transportation sector in North Carolina.

Sincerely,

Selena Lauterer
913 Queen Street
Selena, NC 28607
slauterer@gmail.com
(828) 713-2255

This message was sent by KnowWho, as a service provider only, on behalf of the individual noted in the sender information.

From: Andrea biondi (abiondi@email.unc.edu) Sent You a Personal Message
To: [daq.NC_VWGrants](#)
Subject: [External] Use Volkswagen funds to electrify NC transportation
Date: Tuesday, December 05, 2017 4:23:45 PM

CAUTION: External email. Do not click links or open attachments unless verified. Send all suspicious email as an attachment to report.spam@nc.gov.

Dear Division of Air Quality,

I am writing to urge DEQ to wisely invest the \$92 million in Volkswagen settlement funds in electric vehicles and infrastructure. Taking advantage of these funds to jumpstart the electrification of North Carolina's transportation sector will mean less money sent out of state for petroleum, more in-state jobs, and cleaner air.

Specifically, I recommend that DEQ allocate the maximum allowable amount (15%) of the funds for electric vehicle charging infrastructure and installations. And I encourage DEQ to prioritize electric vehicles and buses for replacement whenever possible with the other 85% of the settlement funds. Doing so will maximize the local economic impact and the reduction of air pollution.

I encourage you to not use the funding for natural gas, propane or diesel vehicles. Further dependence on fossil fuels means more pollution. Only a transition to electric vehicles and investment in EV infrastructure will put us on the road to a 100% clean transportation sector in North Carolina.

Sincerely,

Andrea biondi
6237 hilbert Ridge Drive
holly springs, NC 27540
abiondi@email.unc.edu
(919) 557-5899

This message was sent by KnowWho, as a service provider only, on behalf of the individual noted in the sender information.

From: Tom Leonard (leonardtm@gmail.com) Sent You a Personal Message
To: [daq.NC_VWGrants](#)
Subject: [External] Use Volkswagen funds to electrify NC transportation
Date: Tuesday, December 05, 2017 4:23:45 PM

CAUTION: External email. Do not click links or open attachments unless verified. Send all suspicious email as an attachment to report.spam@nc.gov.

Dear Division of Air Quality,

I am writing to urge DEQ to wisely invest the \$92 million in Volkswagen settlement funds in electric vehicles and infrastructure. Taking advantage of these funds to jumpstart the electrification of North Carolina's transportation sector will mean less money sent out of state for petroleum, more in-state jobs, and cleaner air.

Specifically, I recommend that DEQ allocate the maximum allowable amount (15%) of the funds for electric vehicle charging infrastructure and installations. And I encourage DEQ to prioritize electric vehicles and buses for replacement whenever possible with the other 85% of the settlement funds. Doing so will maximize the local economic impact and the reduction of air pollution.

I encourage you to not use the funding for natural gas, propane or diesel vehicles. Further dependence on fossil fuels means more pollution. Only a transition to electric vehicles and investment in EV infrastructure will put us on the road to a 100% clean transportation sector in North Carolina.

Sincerely,

Tom Leonard
551 Cobbs Creek Rd
Boone, NC 28607
leonardtm@gmail.com
(828) 268-0945

This message was sent by KnowWho, as a service provider only, on behalf of the individual noted in the sender information.

From: Chesley Hight (chesley.hight@yahoo.com) Sent You a Personal Message
To: [daq.NC_VWGrants](#)
Subject: [External] Use Volkswagen funds to electrify NC transportation
Date: Tuesday, December 05, 2017 4:23:34 PM

CAUTION: External email. Do not click links or open attachments unless verified. Send all suspicious email as an attachment to report.spam@nc.gov.

Dear Division of Air Quality,

I am writing to urge DEQ to wisely invest the \$92 million in Volkswagen settlement funds in electric vehicles and infrastructure. Taking advantage of these funds to jumpstart the electrification of North Carolina's transportation sector will mean less money sent out of state for petroleum, more in-state jobs, and cleaner air.

Specifically, I recommend that DEQ allocate the maximum allowable amount (15%) of the funds for electric vehicle charging infrastructure and installations. And I encourage DEQ to prioritize electric vehicles and buses for replacement whenever possible with the other 85% of the settlement funds. Doing so will maximize the local economic impact and the reduction of air pollution.

I encourage you to not use the funding for natural gas, propane or diesel vehicles. Further dependence on fossil fuels means more pollution. Only a transition to electric vehicles and investment in EV infrastructure will put us on the road to a 100% clean transportation sector in North Carolina.

Sincerely,

Chesley Hight
400 S Lakeside Dr
Raleigh, NC 27606
chesley.hight@yahoo.com
(480) 522-5510

This message was sent by KnowWho, as a service provider only, on behalf of the individual noted in the sender information.

From: Linda Orlandi (Imorlan2@ncsu.edu) Sent You a Personal Message
To: [daq.NC_VWGrants](#)
Subject: [External] Use Volkswagen funds to electrify NC transportation
Date: Tuesday, December 05, 2017 4:22:44 PM

CAUTION: External email. Do not click links or open attachments unless verified. Send all suspicious email as an attachment to report.spam@nc.gov.

Dear Division of Air Quality,

I am writing to urge DEQ to wisely invest the \$92 million in Volkswagen settlement funds in electric vehicles and infrastructure. Taking advantage of these funds to jumpstart the electrification of North Carolina's transportation sector will mean less money sent out of state for petroleum, more in-state jobs, and cleaner air.

Specifically, I recommend that DEQ allocate the maximum allowable amount (15%) of the funds for electric vehicle charging infrastructure and installations. And I encourage DEQ to prioritize electric vehicles and buses for replacement whenever possible with the other 85% of the settlement funds. Doing so will maximize the local economic impact and the reduction of air pollution.

I encourage you to not use the funding for natural gas, propane or diesel vehicles. Further dependence on fossil fuels means more pollution. Only a transition to electric vehicles and investment in EV infrastructure will put us on the road to a 100% clean transportation sector in North Carolina.

Sincerely,

Linda Orlandi
419 Normandy Street
Cary, NC 27511
Imorlan2@ncsu.edu
(919) 515-3917

This message was sent by KnowWho, as a service provider only, on behalf of the individual noted in the sender information.

From: Melissa Williams (designwithx@gmail.com) Sent You a Personal Message
To: [daq.NC_VWGrants](#)
Subject: [External] Use Volkswagen funds to electrify NC transportation
Date: Tuesday, December 05, 2017 4:22:24 PM

CAUTION: External email. Do not click links or open attachments unless verified. Send all suspicious email as an attachment to report.spam@nc.gov.

Dear Division of Air Quality,

I am writing to urge DEQ to wisely invest the \$92 million in Volkswagen settlement funds in electric vehicles and infrastructure. Taking advantage of these funds to jumpstart the electrification of North Carolina's transportation sector will mean less money sent out of state for petroleum, more in-state jobs, and cleaner air.

Specifically, I recommend that DEQ allocate the maximum allowable amount (15%) of the funds for electric vehicle charging infrastructure and installations. And I encourage DEQ to prioritize electric vehicles and buses for replacement whenever possible with the other 85% of the settlement funds. Doing so will maximize the local economic impact and the reduction of air pollution.

I encourage you to not use the funding for natural gas, propane or diesel vehicles. Further dependence on fossil fuels means more pollution. Only a transition to electric vehicles and investment in EV infrastructure will put us on the road to a 100% clean transportation sector in North Carolina.

Sincerely,

Melissa Williams
115 Estelle Park Drive
Asheville, NC 28806
designwithx@gmail.com
(828) 545-0443

This message was sent by KnowWho, as a service provider only, on behalf of the individual noted in the sender information.

From: Pendergrass, Bob
To: [daq.NC_VWGrants](#)
Subject: [External] Suggestion for VW Settlement
Date: Wednesday, November 22, 2017 8:08:30 AM

CAUTION: External email. Do not click links or open attachments unless verified. Send all suspicious email as an attachment to report.spam@nc.gov.

Hi, as a long term manager for a local environmental education facility, I welcome the opportunity to comment on spending of funds for the VW settlement.

I think that as much of the funds as possible should be spent on zero emissions vehicle support and promotion- charging stations, EV mass transit, etc. If possible, I think it would be great if some funds could be spent to encourage consumer involvement with ZEV, possibly through purchase rebates or tax incentive. But probably the best use would be to expand an electric charging system for our state, across the state strategically placed along major highways, possible located at our wonderful rest areas that we have giving travelers a break while their vehicles charge up.

Thank you.

Bob Pendergrass

**Bob Pendergrass,
Animal Services Director
Rowan County
1465 Julian Rd
Salisbury Nc 28146**

**704 216-7796
Bob.pendergrass@rowancountync.gov**

Phillips, Brian

From: Amy Miller-Lamb <amy.millerlamb@gmail.com>
Sent: Friday, December 29, 2017 11:44 PM
To: daq.NC_VWGrants
Subject: [External] Response to NC VW RFI

CAUTION: External email. Do not click links or open attachments unless verified. Send all suspicious email as an attachment to report.spam@nc.gov.

This letter is regarding suggestions on how to spend 92 million dollars to help clean the diesel fuel from the air.

Listen to the scientists of our state. Get actual data support and ignore party lines. Spend this money on the actual problem not filling the pockets of your lobbyists and campaign donors. I know that's a big ask, but think of North Carolina instead.

Look to renewable energy, look at solar panels and electric cars. Most importantly look at financing ways to hold corporate polluters accountable so they w
foot the clean up costs, not tax payers.

Sincerely
Amy Lamb

Phillips, Brian

From: Chris Scott <cscott@nczoo.com>
Sent: Wednesday, November 22, 2017 9:18 AM
To: daq.NC_VWGrants
Subject: [External] Promotin Zero Emissions Vehicles

CAUTION: External email. Do not click links or open attachments unless verified. Send all suspicious email as an attachment to report.spam@nc.gov.

Hello,

I am a grant writer and fundraiser for the North Carolina Zoological Society. We have a current project here at the North Carolina Zoo to install multiple electric vehicle charging stations.

We have received financial support for about half of the project from a local company. We still need approximately \$16 to \$20 thousand to cover the remaining costs of the project. Once completed, we would have four electric vehicle charging stations available for use by zoo visitors. This would support and encourage electric vehicle usage, and would do so in a highly visible location, visited by hundreds of thousands of people annually.

This project seems like a good fit, for a possible application of the VW settlement funds. What can I do to further this discussion, or otherwise gain more information?

Thank you for your time and consideration.

Sincerely,
Chris

Christopher T. Scott, JD
Development Officer
North Carolina Zoological Society
336-879-7256
cscott@nczoo.com

The NC Zoo Society is a private, 501(c) 3, non-profit organization that exists to rally support for the Zoo and its missions in education, conservation, research and recreation. Our goal is to secure a safe and long future for the Zoo and its programs.

Phillips, Brian

From: John Langaker <johntlangaker@gmail.com>
Sent: Saturday, December 30, 2017 9:34 PM
To: daq.NC_VWGrants
Subject: [External] VW settlement funds suggestion

CAUTION: External email. Do not click links or open attachments unless verified. Send all suspicious email as an attachment to report.spam@nc.gov.

I would like to suggest we invest in public 220v charging stations, such as ChargePoint stations, for non-Tesla plug-in electric vehicles, for like my Volt, near popular beaches like Topsail Island, so that all EV owners can make a direct mobile emissions impact when they visit the area instead of running on gas.

Thanks,

John Langaker
131 Mayfield Drive
Apex, NC 27539
913-620-4156

Sent from [Mail](#) for Windows 10



Kim Pittel
Group Vice President
Sustainability, Environment & Safety Engineering
Ford Motor Company

Ford World Headquarters
One American Road
Dearborn, MI 48126-2738 USA

February 15, 2018

NC VW Settlement RFI
Division of Air Quality – Mobile Sources
217 West Jones Street
Raleigh, NC 27603

Subject: Ford Motor Company's Input on VW Draft Beneficiary Mitigation Plan Appendix D

Dear Sir or Madam:

Thank you for this opportunity for Ford Motor Company to provide input on the use of your state's Environmental Mitigation Trust (EMT) funds.

Vehicle electrification is core to Ford Motor Company. We introduced the Escape Hybrid nearly 20 years ago; our Hybrid and Plug-in vehicles are among the best sellers in the industry, and we recently announced plans to invest more than \$11 billion in electrification by 2022. Ford believes that the future of transportation is electrified, and this future will benefit both our customers and the environment.

Substantial challenges must be overcome before this future can be realized. A principal challenge is the significant shortfall in publicly available EV charging.¹ For this reason, **we encourage North Carolina to utilize the maximum allowable 15% toward light duty electric vehicle charging infrastructure.**

CHARGER SITING RECOMMENDATIONS

Charging infrastructure must meet both daily driving and long distance travel needs.

Daily Driving: Charge While Parked

While high-speed DC Fast Charging (DCFC) is essential for EVs driving long distance, this 'while you wait' model is a poor solution for day-to-day EV usage. A common 50 kW DC Fast Charger requires **nearly 45 minutes** to add 100 miles of range, significantly affecting the driver's daily routine. Meanwhile, the average vehicle is parked for 22 hours a day.² **Charging while parked** is the superior solution.

Charging while parked at home, work, or destinations conveniently incorporates charging into daily routines. It also allows use of lower power Level 2 (L2) AC chargers, which, compared to DCFC, are cheaper to install and operate³ and provide lower priced electricity to consumers.

Ford recommends that North Carolina fund L2 charging **where vehicles park on a routine basis**. While there are several options for more L2 charging, such as on-street charging (e.g., lamppost retrofits) in high density neighborhoods, Ford believes that chargers at workplaces will provide the greatest impact. Therefore, funding of **workplace charging** should be prioritized.

¹ US DOE. National Plug-In Electric Vehicle Infrastructure Analysis (<https://www.nrel.gov/docs/fy17osti/69031.pdf>).

² Source: AAA and Ford Analytics.

³ https://www.afdc.energy.gov/uploads/publication/evse_cost_report_2015.pdf

The unique benefits of **workplace charging** include the following:

- **Increased EV adoption.** Workplaces become EV showcases. US DOE data suggests that employees with workplace charging are 6 times more likely to purchase an EV. Ford's own experience installing over 200 L2 chargers at our offices and manufacturing plants demonstrated a clear increase in EV adoption and increased electric vehicle miles driven for plug-in hybrids.⁴
- **Routine.** The majority of drivers park at their workplace for 4-10 hours on Monday through Friday. This parking time is sufficient to meet most drivers' range needs with L2 chargers.
- **Alternative for Multi-Unit Dwelling (MUD) Residents.** Workplace charging gives those with limited 'home charging' options an affordable place to charge, expanding the EV market.

Long Distance Travel: Highway Corridor Charging

While there are several solutions for routine charging, long distance travel is impossible without a 'while you wait' model of DCFC along major highway corridors. A complete intercity DCFC network is required for most drivers to adopt an EV as their only vehicle. Therefore, EMT funds should also be directed towards **highway DCFC fast chargers**. To prevent long lines and impractical charge times, highway DCFC stations should have 100-150 kW capability or greater.

POLICY RECOMMENDATIONS

In addition to our funding allocation recommendations, Ford recommends the following policy items.

Coordinate Efforts

In order to ensure the most cost effective and grid responsible build out of charging infrastructure, Ford encourages North Carolina to coordinate with local utilities and other key stakeholders in strategic planning efforts. We encourage North Carolina to consider related programs like the VW National ZEV Investment Plan.

North Carolina is also in a unique position to increase the impact of EMT funds through concurrent development of EV-friendly policy, including:

- **Building Code** modifications to require new or modified residential and commercial parking be charger 'make ready,' including conduit installation and service panel upgrades.
- **Complementary Incentives** like utility charger installation support (e.g., transformer upgrades) or free permitting.

Ensure a Positive Consumer Experience

In addition to intelligent siting, deploying easy-to-use equipment maximizes the impact of new public chargers. As such, projects should meet the following customer protection principles⁵:

- **Payment Interoperability.** Public chargers should accept a standard method of payment (credit card or mobile app like ApplePay) rather than a dedicated card or key, which can leave drivers stranded.

⁴ <https://www.slideshare.net/emmaline742/stephanie-janczakcharging-up-at-work-november-2017>

⁵ Similar comments were provided to Connecticut DEEP by Plug-In America, a non-profit organization that bills itself as the "national consumer voice for plug-in electric vehicles."

- **Transparency.** The price of a charge should be clear to the driver, both at the point of sale and also via any charger locator apps.
- **Mapping Data.** All electric vehicle service providers (EVSPs) should make mapping data for charging locations readily available, including, as noted above, charging costs.
- **Signage.** Even when shown in a mapping app, chargers can be difficult to locate. Charging stations should have adequate signage, from highway visibility down to the last few feet. Signage provides the additional benefit of increasing charger visibility for non-EV drivers considering EV adoption.
- **Accessibility.** Charger installation projects should be designed in accordance with Title III of the Americans with Disabilities Act (ADA), giving people with disabilities the option to 'go electric.'⁶

Provide Competitive Bidding

North Carolina can best accelerate sustainable growth of public charging infrastructure by funding a diverse cross-section of the charging industry. To this end, the state should support competition and allow multiple vendors and business models to participate.

In summary, Ford recommends that a **full 15%** of EMT funds be allocated towards light duty charging and be spent primarily on **workplaces** and **highway** corridors. Ford also recommends a number of policy items to support the coordination of efforts to deploy chargers. If you would like to discuss further, please contact Justin Heinonen, Ford's Government Relations Representative for North Carolina, at jheinon3@ford.com or 313-390-5448.

Sincerely,



Kim Pittel
Group Vice President
Sustainability, Environment & Safety Engineering
Ford Motor Company

⁶ Resource: *ADA Requirements to Consider for Workplace Charging Installation* (<http://vwclearinghouse.org/resource/ada-requirements-for-workplace-charging-installation/>).

Grant Millin Fuel Cells and Hydrogen Infrastructure

NC VW Beneficiary Mitigation Plan RFI Response

December 31, 2017

Executive Summary

The Volkswagen diesel settlement includes nitrogen oxide mitigation options and funding for state. One of the options is zero emission vehicles (ZEVs). The definition of ZEV includes fuel cell electric vehicles (FCEVs). Essentially the entire state of North Carolina with the support of Duke Energy seems to be focused on battery only electric vehicles (BEVs), or what are called plug-in electric vehicles. FCEVs also include batteries but use hydrogen for optimal range. There are no BEVs with the range of FCEVs, being three times the range of BEVs. Technological innovation and the lightness of hydrogen mean FCEVs will always be lighter and have greater range than BEVs.

This citizen response to the State of North Carolina VW Beneficiary Mitigation Trust RFI is designed to:

- 1) Establish the role of FCEVs as the other side of ZEV policy.
- 2) Provide rationale and current samples of market and policy information otherwise not present in our state.
- 3) Provide a specific example of hydrogen fueling stations required to deploy FCEVs in our state.

Further steps beyond a financial commitment from State of North Carolina have to do with policy changes. One of these includes becoming a ZEV Alliance state based of California Air Resources Board parameters. Like solar and wind power, CleanTech markets invariably start with government intervention. In the same way Duke Energy controls its market share and technological choices through government, the future of climate change strategy and mitigation of NOX includes government action of a responsible innovation nature.

Introduction

The other rationale for using VW Beneficiary Mitigation Trust funds for ZEVs to include FCEVs beyond allowing North Carolina citizens and visitors the greater range and other performance features of FCEVs is addressing greenhouse gases driving our state contribution to human-caused climate change. Concerning transportation GHGs an accurate analysis of the GHGs coming from the millions of annual tourist car trips to Asheville is needed. Then there are all those trucks.

Diesel trucks traveling I-40 and I-26 along with short local commercial trips contribute significantly to the total Asheville and Buncombe transportation GHG number. What to do?

Climate protection and reliable transportation answers include FCEVs. Fuel cells exploit the natural hydrogen-oxygen bond of water to make electricity... with water as the only exhaust. Tesla's proposed *Semi* battery only truck has a hydrogen fuel cell competitor. Ironically it's called the Nikola One. Toyota, the globe's largest vehicle manufacturer, offers FCEVs and at least ten other companies offer FCEVs or will soon.

Including personal vehicles and buses, why should North Carolina deny the option of longer range FCEVs... all travelling alongside battery only electric vehicles? Who decides whether we can drive either type of zero emission vehicle?

Those are sample CleanTech transportation sector questions and solutions. What about reliably turning on the lights across North Carolina, while doing the maximum to protect the climate today and over coming decades?

Grid fuel cells are cutting GHGs in North Carolina now, but Duke Energy pretends they are not an option... despite Duke Energy and the NC Utilities Commission approving the Apple data center in Maiden, NC five years ago... that today is partially powered by a fuel cell-biogas-solar system.

Fuel cells are just one step to going deeper and bigger with CleanTech innovation. But what else is there to understand and act on?

North Carolina's responsible energy portfolio includes H2

North Carolina is ready for fuel cells and hydrogen fueling stations. The next several weeks are an important period for anyone interested in expanding North Carolina's energy innovation options and climate response. Hydrogen is clearly part of the solution.

Hydrogen solutions are in a new market position from a decade ago.

Combined with North Carolina's Volkswagen settlement distribution, NC House Bill 589 "Competitive Energy Solutions for NC" left a back door for installing our first public-access, hydrogen-fueling stations. There is a section in HB 589 covering an energy-storage study. The current players behind this \$150,000 study believed they had a "hydrogen excluding" definition of energy storage locked. If they do not include hydrogen, the study will be another unnecessarily biased policy outcome.

But more is needed. To stimulate deployment of CleanTech hydrogen use in North Carolina I am willing to help organize the NC Zero Emission Vehicle and Grid Fuel Cell Working Group (ZEV-GFC Working Group).

I have shared U.S. Department of Energy findings and other evidence with the governor and N.C. Department of Environmental Quality that community hydrogen production and storage technology is just as much of an example of modern low / zero emission energy storage as

batteries. These solutions are not meant to be at odds with one another but rather fill out the blanks in a responsible energy-innovation outcome for each of our municipalities.

A determination by Governor Cooper and the N.C. Joint Legislative Commission on Energy Policy is needed that: 1) Hydrogen energy storage in both transportation and electric-grid modalities are part of the HB 589 energy storage parameters; and 2) That the N.C. VW Beneficiary Mitigation Plan will help fund at least two public-access, hydrogen-fueling stations in our state: one in Asheville and one near RDU. These first stations will serve North Carolina fuel cell electric vehicles, from personal and fleet cars to buses to long-haul trucks, all with ranges surpassing battery-only vehicles.

There is no good reason for them to say no. Here are some preliminary bullet points for getting moving:

- At the 2017 COP23 climate summit in Bonn, Germany, the Hydrogen Council presented a roadmap for hydrogen providing approximately 20 percent of the responsible global climate solution.
- The VW Beneficiary Mitigation Plan funds designated for North Carolina allow for hydrogen fueling stations. The HB 589 energy storage study allows for hydrogen.
- Like the way fuel cell forklifts in the Carolinas were an early commercial large-scale use of hydrogen, semi-tractors are also next. The Tesla Semi has a previously announced hydrogen competitor.
- Hydrogen safety standards for community use have been in place for years. There are no coal ash or oil spills from using hydrogen this way.
- While Duke Energy has erased any mention of grid fuel cells in their 2017 Integrated Resources Plan, they and the N.C. Utilities Commission approved an Apple grid fuel cell installation several years ago. As another grid fuel cell case study, Duke University and central Durham's energy needs would likely benefit from a fuel cell microgrid / combined heat and power solution.

The Honda Smart Hydrogen Station (2016-2017 era) covered as a sample Fuel Cell and Hydrogen Infrastructure (FCH2) technology for this RFI response is only one product example. What FCH2 options are available in the US is all part of the ZEV-GFC Working Group outcomes and further support. Along with launching the ZEV-GFC Working Group, respondent is seeking support for an overall related nonprofit.



Source: Honda

- For those who believe in a “100 percent renewables only” future, all the supporting analysis attempting to prove such an outcome includes hydrogen.
- Next steps for North Carolina since joining the U.S. Climate Alliance include becoming a Zero Emission Vehicle state per California Air Resources Board policy. That means adding fuel cell electric vehicles here and being another state with more influence over the transportation industry.

If North Carolina continues to skip solutions like hydrogen, that means we as a state set the grid resilience and sustainability innovation bar lower. If the USA comes up 20 percent short when we could have securely gone further, that means the climate impact will be that much worse. We can't risk North Carolina and our nation getting this wrong as we have just one chance.

To learn more, join the ZEV-GFC Working Group by contacting grantmillin@gmail.com and visit HydrogenNC.com. Hydrogen Power for North Carolina is one part of Sustain NC. Both are programs of a future nonprofit.

Grant Millin lives in Asheville and was the North Carolina project manager of the Hydrogen Road Tour. He is the Sustain NC developer.

Section 1 - Project Applicant Information

Grant Millin, Innovation Strategist and Owner (RFI Respondent)
InnoGraph - Strategic Innovation Services and Management Consulting
Sustain NC Developer

615 Biltmore Avenue W-1

Asheville, NC 28803

Cell: 828.423.2266

Email: grantmillin@gmail.com

URLs: www.innovograph.com / www.sustainnc.com / www.sgdeep.com / www.hydrogennc.com

[Biographical sketch](#)

Nongovernment respondent

Section 2 – VW Program and Solicitation Design Questions

Respondents should consider providing information in response to the following questions:

1. How should DEQ prioritize projects?

ZEVs are part of responsible climate and air pollution action. Whether its NOX or PM 2.5, ZEVs are the primary long-range solution while offering reliable transportation. However without FCH2, a large portion of this CleanTech portfolio for North Carolina is needlessly eliminated.

2. What is the anticipated demand for each eligible project type?

FCEVs are procured when the hydrogen station-FCEV manufacturer relationships have produced outcome. The ZEV-GFC Working Group is available to develop this side of North Carolina's CleanTech portfolio.

3. The percentage of trust funds, if any, that DEQ should devote to Light Duty Zero Emission Vehicle Supply Equipment?

This RFI response recommends two hydrogen fueling stations be supported, one in Asheville and one near RDU, as part of North Carolina new ZEV program. A minimum of \$250,000 is suggested to support a cost share plan for these initial public, credit card payment North Carolina hydrogen fueling stations.

4. What is the anticipated demand for specific types of diesel emission reduction projects not eligible under the VW settlement but otherwise eligible under DERA or other state programs?

Not addresses, except as to importance of developing a true North Carolina ZEV / CleanTech program inclusive of FCH2.

5. Should a certain percentage of available VW funds be allocated to each eligible project type and if so how should the percentage be determined?

BEVs are supported by conventional CleanTech wisdom in this state. This is part of why only a

small percentage of the total NC VW ZEV allocation is suggested.

6. Should a certain percentage of available Mitigation Trust funds be reserved for government projects?

Part of the new North Carolina ZEV program needs to include funding for public awareness programs. The VW ZEV Investment Plan component of the VW settlement allows for public trust education. FCH2 needs to be emphasized in North Carolina's new ZEV / CleanTech programs.

7. Should funds be geographically distributed, and if so how?

This RFI response recommends two initial hydrogen fueling stations, one in Asheville and one near RDU, be supported by the NC VW Beneficiary Mitigation Plan and future ZEV / CleanTech programs.

8. Should governmental entities be required to provide matching funds and if so, how much?

The US Department of Energy, EPA, and DOT are FCH2 partners, including as to financing.

9. Should DEQ establish a minimum project size and if so, what size?

Project size is relative and ancillary to CleanTech social, environmental, and economic impacts. FCH2 cost / benefit analysis will be covered in more depth by the ZEV-GFC Working Group as it develops.

10. In addition to evaluating a proposed project's total cost effectiveness (\$/ton), what other key factors should DEQ consider when evaluating projects?

See answer #9

11. What other feedback do you have on project evaluation and/or scoring criteria?

Further stakeholder engagement is needed in developing new North Carolina ZEV / CleanTech programs. Such program questions will be addressed in further ZEV-GFC Working Group actions.

12. What publicly available tool(s) should be used to quantify anticipated emission reductions/offsets for eligible mitigation projects? What, if any, additional resources should be provided and made available?

See answer #9 and #11

13. What methods could DEQ employ to reduce barriers and increase participation in future solicitations for projects?

See answer #9 and #11

14. What information/resources would be most valuable for stakeholders interested in submitting projects and what is the best way to communicate those?

See answer #9 and #11

Section 3 - Applicable Eligible Mitigation Project Category

Light Duty (LD) zero emission vehicle (ZEV) Supply Equipment: Hydrogen Fuel Dispensing Equipment

Project Summary:

Asheville-RDU Hydrogen Station Installations

Briefly describe the proposed project:

Fuel cell buses, POVs, and long-haul trucks would be facilitated by the initial hydrogen fueling stations in North Carolina.

Mitigation action: of LD ZEV supply equipment

Number of engines/vehicles/vessels/equipment targeted for emission reductions: ZEVs are petroleum ICE replacement technologies. Eventually the entire issue of emissions are resolved through increasing ZEV and other CleanTech actions.

Emission reduction/offset technology to be used: FCEVs requiring hydrogen fueling stations.

Estimated cost of project:

ZEVs including FCEVs mitigate all emissions. Further data is cost prohibitive at this time. Honda Smart Hydrogen Stations are reported to cost minimum estimated \$450,000 USD before all other project costs. If available in the US in 2018, Honda Smart Hydrogen Stations are only one FCH2 technical solution.

As to FCEVs, Toyota Mirais lease for \$349 USD, less than a Ford Edge.

Project Detail:

Further data is cost prohibitive at this time. Detailed North Carolina ZEV and other CleanTech programming is needed.