

C-1. Infiltration System



Design Objective

An infiltration system captures stormwater runoff and allows it to infiltrate into the soil. This SCM (along with permeable pavement) is typically the work horse of a runoff volume match site because it helps the site to mimic pre-development hydrology and therefore helps to protect the structure of the receiving stream. Infiltration systems work best when their drainage areas are mostly impervious, as pervious surfaces can contribute fines that clog the soil. This section discusses two types of infiltration devices: infiltration trenches (Figure 1) and infiltration basins:

- **Infiltration Trenches** are filled with stone or other media to store stormwater in the voids between. Some infiltration trenches use precast concrete vaults with open bottoms to provide a large storage volume to hold stormwater for infiltration into the soil. Infiltration trenches are usually used to manage the runoff from parking lots and buildings.
- **Infiltration Basins** are depressions that capture, store and allow stormwater to infiltrate into the soils.

Design Volume

The design volume for an infiltration device is equivalent to the volume that is completely draw down to the bottom of the infiltration system within 72 hours.

Important Links

[Rule 15A NCAC 2H .1051. MDC for Infiltration Systems](#)

[SCM Credit Document, C-1. Credit for Infiltration Systems](#)

Table of Contents

Underground Injection Wells

Guidance on the MDC

- MDC 1: Soil Investigation
- MDC 2: Separation from the SHWT
- MDC 3: Soil Subgrade Surface
- MDC 4: Pretreatment
- MDC 5: Drawdown Time
- MDC 6: Observation Port

Recommendations

- Recommendation 1: Trench Media
- Recommendation 2: Trench Geotextiles
- Recommendation 3: Pumped Infiltration

Construction

Maintenance

- Operation and Maintenance for Infiltration Trenches
- Operation and Maintenance for Infiltration Basins

Old Versus New Design Standards

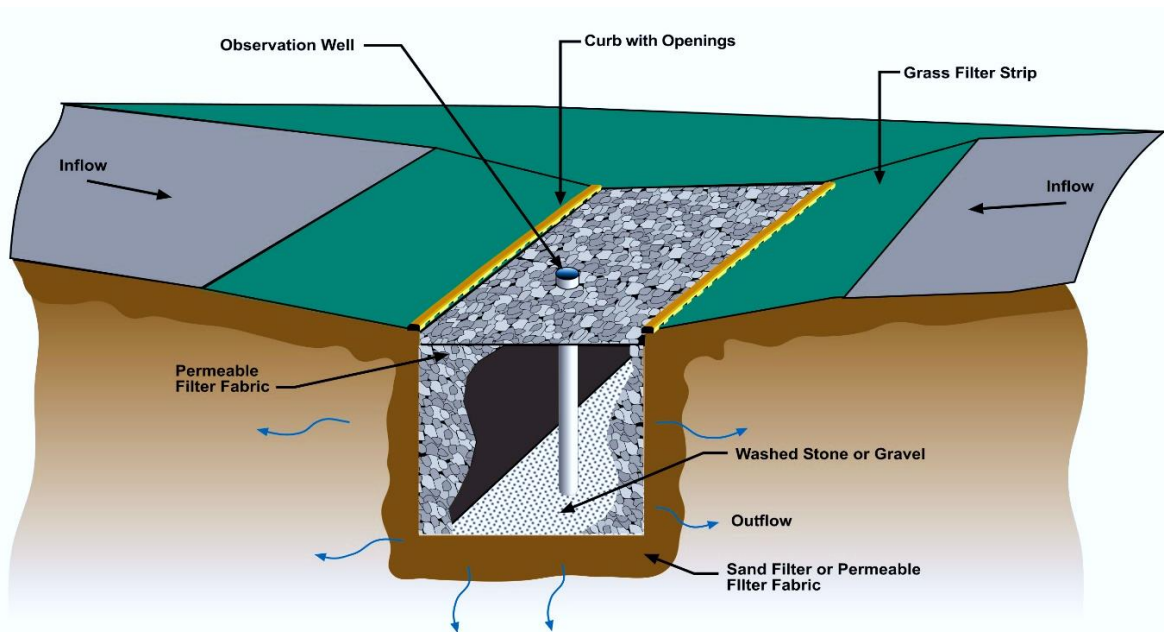
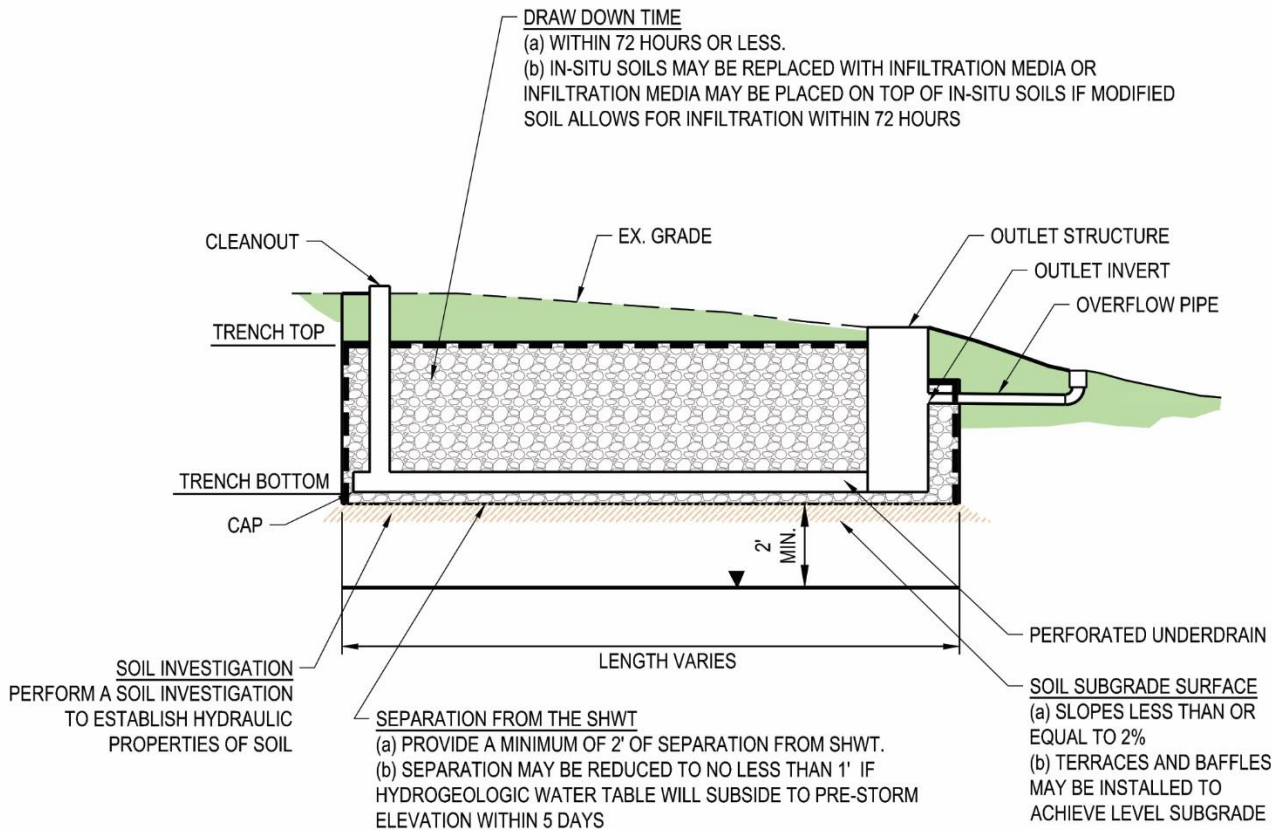

Figure 1: Infiltration Trench: Example Section View



- PROVIDE PRE-TREATMENT DEVICES TO PREVENT CLOGGING (E.G. SUMPS IN CATCH BASINS, GRAVEL VERGES, SCREENS ON ROOF AND PATIO DRAINS, FILTER STRIPS, GRASSED SWALES, AND FOREBAYS). ROOFTOP RUNOFF DISCHARGED TO THE SURFACE OF AN INFILTRATION SYSTEM DOES NOT REQUIRE PRETREATMENT
- FOR INFILTRATION DEVICES LOCATED UNDER THE GROUND SURFACE, PROVIDE A MINIMUM OF 1 INSPECTION PORT

Class V Stormwater Drainage Well Requirements

Class V stormwater drainage wells are defined in EPA’s Underground Injection Control regulations (40 CFR144.3) as:

A bored, drilled, or driven shaft whose depth is greater than the largest surface dimension; or, dug hole whose depth is greater than the largest surface dimension; or, an improved sinkhole; or, a subsurface fluid distribution system.

Class V wells are a specific type of well that are used to inject non-hazardous fluids, including stormwater, underground. Infiltration systems can sometimes meet the definition of Class V wells, in which case they are referred to as stormwater drainage wells. Per the requirements of 15A NCAC 02C .0227, the owner of a stormwater

infiltration system that meets the definition of a Class V Stormwater Drainage Well must submit a notification form to the NC Division of Water Resources' Underground Injection Control (UIC) Program in order to comply with federal injection well inventory reporting requirements. The Stormwater Drainage Well Notification Form can be found on [DWR's Stormwater Injection](#) page. The paragraphs below describe which types of infiltration systems do not require notification, which ones are not allowed and which ones do require notification.

Infiltration Systems that do not Require Notification

Infiltration basins without any pipes to convey stormwater into the ground do not require notification. In addition, infiltration trenches designed in accordance with Figure 1 above are not stormwater drainage wells because the purpose of the underdrain pipe system is for collecting overflow rather than for distributing stormwater.

Infiltration Systems that are not Allowed

Under NC rules, untreated stormwater is not allowed to be injected directly into any aquifer. This includes injecting stormwater into an improved sinkhole or into a vertical well into the ground as depicted in Figure 2 below.

Figure 2: An Example of a Class V Drainage Well (EPA)

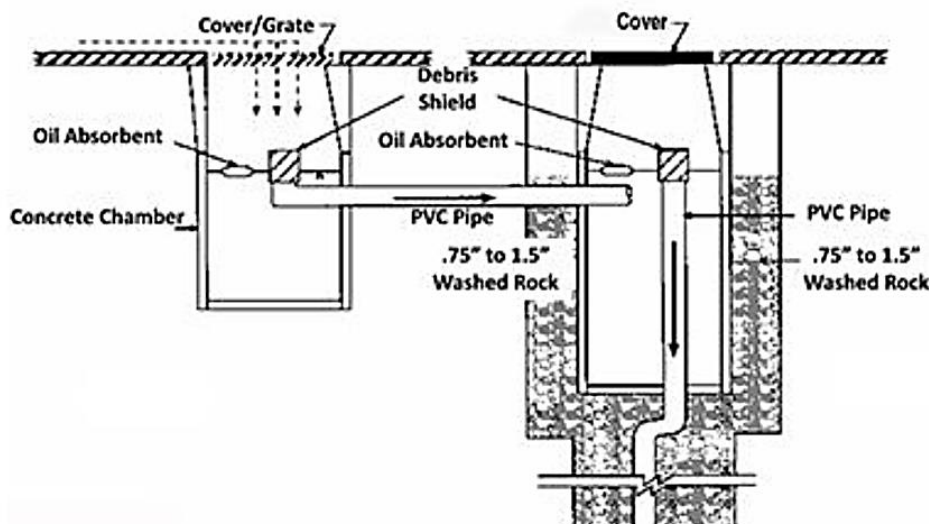

Infiltration Systems Requiring Notification to [DWR's Stormwater Injection Program](#)

DEQ considers infiltration systems to be stormwater drainage wells if they meet one of the following criteria:

1. An infiltration trench or subsurface infiltration system whose depth is larger than its smallest surface dimension.

2. The separation from the bottom of the infiltration system to the seasonal high water table (SHWT) is less than 2 feet (note that additional requirements must also be met to reduce the separation from the SHWT per [MDC 2: Separation from the SHWT](#)).
3. The groundwater table is artificially lowered to create sufficient separation from the SHWT for infiltration to occur.
4. A stormwater infiltration system that uses pipes to distribute stormwater (rather than collect and bypass stormwater overflow), such as the one shown in Figure 3 below.

Figure 3: An Example of an Infiltration System with Piped Stormwater Distribution (StormTech)



Stormwater infiltration systems that fall into one of the four criteria listed above do not need a separate permit from the DWR Underground Injection Control (UIC) Program; however, a notification form must be submitted to the UIC Program in order to comply with federal injection well inventory reporting requirements. The Stormwater Drainage Well Notification Form can be found on DWR's [Stormwater Injection](#) page.

Guidance on the MDC

INFILTRATION MDC 1: SOIL INVESTIGATION.

A site-specific soil investigation shall be performed to establish the hydraulic properties and characteristics of the soil within the proposed footprint and at the proposed elevation of the infiltration system.

See Part A-2 for guidance on soil investigation. It is recommended to provide a minimum of one soil test hole per 5,000 square feet of infiltration surface area.

INFILTRATION MDC 2: SEPARATION FROM THE SHWT.

The lowest point of the infiltration system shall be a minimum of two feet above the SHWT. However, the separation may be reduced to no less than one foot if the applicant provides a hydrogeologic evaluation that demonstrates that the water table will subside to its pre-storm elevation within five days or less.

There are two primary reasons for the two-foot separation requirement; the first is the inherent uncertainty in pinpointing the exact location of the SHWT in the field, and the second is the potential for mounding of the groundwater table in the vicinity of the infiltration system. If the mounding becomes severe enough, the infiltration will not function as designed. See Part A-2 for guidance on what should be provided in a hydrogeologic evaluation.

INFILTRATION MDC 3: SOIL SUBGRADE SURFACE.

The surface of the soil subgrade shall have a slope of less than or equal to two percent. Terraces and baffles may be installed to achieve a level subgrade.

A nearly level soil subgrade slope is necessary to ensure that stormwater will be evenly infiltrated into the soil subgrade.

INFILTRATION MDC 4: PRETREATMENT.

Pretreatment devices shall be provided to prevent clogging. Pretreatment devices may include measures such as sumps in catch basins, gravel verges, screens on roof and patio drains, filters, filter strips, grassed swales, and forebays. Rooftop runoff that is discharged to the surface of an infiltration system shall not require pretreatment.

In selecting a pretreatment device, the designer should consider the slope, land cover, and size of the drainage area. Drainage areas with high slopes, a significant amount of pervious surfaces, or that are larger than an acre should have a more robust pretreatment device like a forebay or sump. Smaller drainage areas with a high percentage of built-upon area can typically have simpler pretreatment systems like filter strips, swales or gravel verges.

INFILTRATION MDC 5: DRAWDOWN TIME.

Infiltration systems shall be designed to dewater the design volume to the bottom of the infiltration device within 72 hours or less. In-situ soils may be removed and replaced with infiltration media or infiltration media may be placed on top of in-situ

soils if the applicant provides a soils report that demonstrates that the modified soil profile allows for infiltration of the design volume within 72 hours or less.

The drawdown time requirement, in combination with the field-determined soil infiltration rate, determines the minimum surface area for an infiltration system. See Equation 1 below.

Equation 2: Minimum Surface Area for an Infiltration System

$$SA = FS * \frac{DV * 12}{K * T}$$

where:

SA	=	required minimum surface area of infiltration system (ft ²)
FS	=	factor of safety (minimum of 2 is recommended)
DV	=	design volume (ft ³)
K	=	hydraulic conductivity of soil (in/hr)
T	=	maximum dewatering time (72 hours)

Although some infiltration will likely occur from the sides of an infiltration system, the DEQ recommends sizing the infiltration system's bottom surface area per this equation and considering infiltration from the sides as a factor of safety.

A factor of safety is crucial in infiltration system design due to the following:

- The inherent uncertainty in soil testing;
- The likelihood that the soil will be compacted during construction, which can reduce soil infiltration rates by more than an order of magnitude; and
- The likelihood that sediment will enter the infiltration system after it is constructed and diminish the infiltration rate. If the system does not drain within 72 hours throughout its operational life, then it will be out of compliance with this MDC.

INFILTRATION MDC 6: OBSERVATION PORT.

For infiltration devices located under the ground surface, a minimum of one inspection port shall be provided.

In order to monitor performance of the infiltration device, observations should be conducted to determine how long it takes retained water to infiltrate into the soil after a storm event

Recommendations

INFILTRATION RECOMMENDATION 1: TRENCH MEDIA.

For infiltration trenches, medium or coarse sand, or crushed stone (i.e., uniformity coefficient of 2 or smaller) is preferable as a drainage medium. Trench media should be hard, durable, inert particles, free from slate, shale, clay, silt, and organic matter.

Uniform materials have higher porosity (which provides a larger storage capacity), which can reduce the amount of space and materials required to construct an infiltration trench. The porosity of the material should be determined by laboratory tests and certified by the supplier.

The trench media should be washed, or preferably, double-washed.

To increase the runoff capture storage volume of trenches, plastic, aluminum or concrete gallery frames can be inserted. The gallery frames introduce open space inside the trench and help distribute flow. Adequate maintenance access must be provided to the gallery frames.

INFILTRATION RECOMMENDATION 2: TRENCH GEOTEXTILES.

For infiltration trenches, drainage media should be enclosed on all sides by a geotextile filter.

Proper specification of the geotextile prevents two problems: accumulation of soil into the device and clogging at the soil interface. The top surface of the geotextile should be 6-12 inches below the upper surface of the drainage media. The other surfaces of the geotextile should be in contact with the in-situ soil. The fabric, together with the overlying material, can be removed and disposed of when excessive sediments accumulate on the filter and begin to retard flow into the device.

INFILTRATION RECOMMENDATION 3: PUMPED INFILTRATION.

If a project has soils with high infiltration rates, but there is not adequate separation from the SHWT at the discharge point, the designer has the option of using “pumped infiltration.”

Pumped infiltration can be a good option for some projects, particularly where SA waters requirements apply. It is typically accomplished by providing a storage pond at the low point of the drainage area and a pump to convey the stormwater to a higher elevation.

DEQ recommends that the following information be considered in the design and provided in the submittal:

1. **Pump elevation:** Set the pump inlet piping at or above sediment cleanout level of the storage pond to avoid clogging the pump. The cleanout

elevation typically corresponds to 0.75 times the design depth of the storage pond.

2. **Routing calculations:** Provide routing calculations that demonstrate that the design volume can be adequately conveyed from the storage pond to the infiltration system during the storm event. The pump should be sized such that the operating point is less than the drawdown rate for the basin.
3. **Gate valve and discharge line size:** Insure that these are provided to adjust and convey flow at system operation point.
4. **Pump system details:** Pump system details should be provided on the plans, calculations, and specifications and should include:
 - a. Sealed TDH calculations with piping and fitting count, operating point, entry and exit losses.
 - b. Pump specification sheet with model number and impeller size.
 - c. Pump curve with operating point.
 - d. The pump “on” elevation at a minimum of four inches above pump “off” elevation identified on the plans (six inches recommended).
 - e. Check valve provided on pump discharge line to prevent backflow when pump is “off.”

Construction

Care should be used during installation to minimize compaction of soil on the bottom and walls of infiltration devices since this will reduce the permeability at the soil interface. To avoid compacting the drainage media, light equipment and construction techniques that minimize compaction should be used.

Runoff shall not be directed into an infiltration device until the drainage area is stabilized. A construction sequence must be followed that reflects the need to protect the functioning of the infiltration device. The longevity of infiltration devices is strongly influenced by the care taken during construction.

Infiltration trenches should not be covered by an impermeable surface unless there is suitable maintenance access, the design specifies a H-20 loading capacity, and the permit application includes a cross-section of the H-20 design. Direct access must be provided to all infiltration devices for maintenance and rehabilitation. OSHA safety standards should be consulted for trench excavation.

A minimum of one observation well shall be included in the design of an infiltration system to periodically verify that the drainage media is fully draining. The monitoring well shall consist of a 4- to 6-inch-diameter, perforated polyvinyl chloride (PVC) pipe with a locking cap. The well should be placed near the center of the facility or in the general location of the lowest point within the facility, with the invert at the excavated bottom of the facility.

Maintenance

For the first year of operation, installations should be inspected monthly and after each major storm. After the first year, quarterly inspections, preferably conducted after a storm, are recommended.

In order to monitor performance of the infiltration device, observations should be conducted to determine how long it takes retained water to infiltrate into the soil after a storm event. The determination can be made in two ways. The most informative way is to read the water level several times over a period of days after a large storm. The alternative is a “one-stop” method, where a single reading is taken and compared with the local rainfall record. Although less accurate than the multiple reading method, the one-stop method will still allow significant deterioration in performance to be recognized.

Maintenance is very important for infiltration devices. Property owners should be educated in the function and maintenance requirements of infiltration devices. Especially important is the maintenance of vegetated areas that drain to the infiltration system. Areas that are allowed to become bare and unvegetated will contribute excess sediment to the infiltration system and hasten its failure. Any sediment deposits in pretreatment devices should be removed at least annually.

The surface of infiltration systems must be kept in good condition. In many instances, it is convenient to cover infiltration trenches with concrete grid pavers or similar permeable paving systems that can be removed easily and replaced as necessary to service the trench.

The top several inches of drainage media and the filter cloth along the top of the drainage media should be replaced annually or at least when the dewatering time is longer than 5 days. If after replacing the top media the infiltration rate is still not in the acceptable range, the entire facility must be dismantled and reconstructed.

Proper disposal of the materials removed is necessary; the aggregate and cloth should be appropriately packaged and delivered to the local landfill, provided the operating authority approves the disposal.

Since infiltration trenches and infiltration basins have different configurations and maintenance needs, an appropriate sample operation and maintenance table is offered for each one.

Sample Operation and Maintenance Provisions for Infiltration Trenches

Important operation and maintenance procedures:

1. The drainage area of the infiltration trench will be carefully managed to reduce the sediment load to the sand filter.

2. The water level in the monitoring wells will be recorded once a month and after every storm event greater than 1.0 inches (or 1.5 inches if in a Coastal County).

The infiltration trench will be inspected **quarterly and within 24 hours after every storm event greater than 1.0 inches (or 1.5 inches if in a Coastal County)**. Records of operation and maintenance will be kept in a known set location and will be available upon request.

Inspection activities shall be performed as follows. Any problems that are found shall be repaired immediately.

Table 1: Sample Operation and Maintenance Provisions for Infiltration Trenches

SCM element:	Potential problem:	How to remediate the problem:
The entire infiltration trench	Trash/debris is present.	Remove the trash/debris.
The grass filter strip or other pretreatment area	Areas of bare soil and/or erosive gullies have formed.	Regrade the soil if necessary to remove the gully, plant ground cover and water until established. Provide lime and a one-time fertilizer application
	Sediment has accumulated to a depth greater than three inches.	Search for the source of the sediment and remedy the problem if possible. Remove the sediment and dispose of it in a location where it will not cause impacts to streams or the SCM.
The flow diversion structure (if applicable)	The structure is clogged.	Unclog the conveyance and dispose of any sediment in a location where it will not cause impacts to streams or the SCM.
	The structure is damaged.	Make any necessary repairs or replace if damage is too much for repair.
The trench	Water is ponding on the surface for more than 24 hours after a storm.	Remove the accumulated sediment from the top of the infiltration trench and dispose of it in a location that will not impact a stream or the SCM.
	Grass or other plants are growing on the surface of the trench.	Do not pull the weeds (may pull out media as well). Wipe them with a systemic herbicide such as glyphosate and then return within the week to remove them by hand. (Another option is to pour boiling water on them or steam them.)

Observation well	Water present more than three days after a storm event	Clean out any clogged underdrain pipes. Consult an appropriate professional for clogged soil subgrade.
The emergency overflow berm	Erosion or other signs of damage have occurred at the outlet.	Repair or replace the berm.
The receiving water	Erosion or other signs of damage have occurred at the outlet.	Repair the damage and improve the flow dissipation structure.
	Discharges from the infiltration trench are causing erosion or sedimentation in the receiving water.	Contact the local NCDEQ Regional Office.

Sample Operation and Maintenance Provisions for Infiltration Basins

Important operation and maintenance procedures:

1. The drainage area will be carefully managed to reduce the sediment load to the infiltration basin.
2. No portion of the infiltration basin will be fertilized after the initial fertilization that is required to establish the vegetation. Lime may be allowed if vegetation is planted on the surface of the infiltration system and a soil test shows that it is needed.
3. The vegetation in and around the basin will be maintained at a height of four to six inches.

After the infiltration basin is established, it will be inspected **quarterly and within 24 hours after every storm event greater than 1.0 inches (or 1.5 inches if in a Coastal County)**. Records of operation and maintenance will be kept in a known set location and will be available upon request.

Inspection activities shall be performed as follows. Any problems that are found shall be repaired immediately.

Table 2: Sample Operation and Maintenance Provisions for Infiltration Basins

SCM element:	Potential problem:	How to remediate the problem:
The entire infiltration basin	Trash/debris is present.	Remove the trash/debris.

The grass filter strip or other pretreatment area	Areas of bare soil and/or erosive gullies have formed.	Regrade the soil if necessary to remove the gully, plant ground cover and water until established. Provide lime and a one-time fertilizer application
	Sediment has accumulated to a depth greater than three inches.	Search for the source of the sediment and remedy the problem if possible. Remove the sediment and dispose of it in a location where it will not cause impacts to streams or the SCM.
The flow diversion structure (if applicable)	The structure is clogged.	Unclog the conveyance and dispose of any sediment in a location where it will not cause impacts to streams or the SCM.
	The structure is damaged.	Make any necessary repairs or replace if damage is too much for repair.
The inlet device	The inlet pipe is clogged (if applicable)	Unclog the pipe and dispose of any sediment in a location where it will not cause impacts to streams or the SCM.
	The inlet pipe is cracked or otherwise damaged (if applicable).	Repair or replace the pipe.
	Erosion is occurring in the swale (if applicable).	Regrade the swale if necessary and provide erosion control devices such as reinforced turf matting or riprap to avoid future erosion problems.
	Stone verge is clogged or covered in sediment (if applicable).	Remove sediment and clogged stone and replace with clean stone.
The basin	More than four inches of sediment has accumulated.	Search for the source of the sediment and remedy the problem if possible. Remove the sediment and dispose of it in a location where it will not cause impacts to streams or the SCM.
	Erosion of the basin surface has occurred or riprap is displaced.	Provide additional erosion protection such as reinforced turf matting or riprap if needed to prevent future erosion problems.
	Water is standing more than three days after a storm event.	Replace the top few inches of soil to see if this corrects the standing water problem. If not, consult an appropriate professional for a more extensive repair.
The embankment	Shrubs or trees are growing on the embankment.	Remove trees and shrubs immediately.

	An annual inspection by an appropriate professional shows that the embankment needs repair.	Make needed repairs immediately.
The outlet device	Clogging has occurred.	Clean out the outlet device and dispose of sediment in a location where it will not cause impacts to streams or the SCM.
	The outlet device is damaged.	Repair or replace the outlet device.
The receiving water	Erosion or other signs of damage have occurred at the outlet.	Repair the damage and improve the flow dissipation structure.
	Discharges from the infiltration trench are causing erosion or sedimentation in the receiving water.	Contact the local NCDEQ Regional Office.

Old Versus New Design Standards

The following is a summary of some of the changes in infiltration system design standards between the archived version of the BMP Manual and the current MDC for infiltration systems. It is intended to capture the highlights only; any infiltration system MDC that are not captured in this table are still required per 15A NCAC 02H .1051.

	Old manual requirements	New MDC
Soil permeability requirements	Infiltration systems only allowed if the in-situ soil has an infiltration rate of at least 0.52 inch/hour.	Infiltration systems shall be designed to dewater in 72 hours or less based on the soil infiltration rate. (Lower infiltration rate soils will require a larger surface area.)
Flow splitting device	Required; only the runoff from the design storm is allowed to be directed to the infiltration system.	Not required. Infiltration systems can be designed with an outlet device that attenuates peak flow above the ponding depth for the design storm.
Level spreader for the overflow	Required	Not required; outlet must be designed so that erosion does not occur.
Maximum depth of media for infiltration trenches	Specified.	Not specified; however, the invert of the infiltration system must meet the SHWT requirements in the MDC.