

D-1. StormFilter by Contech

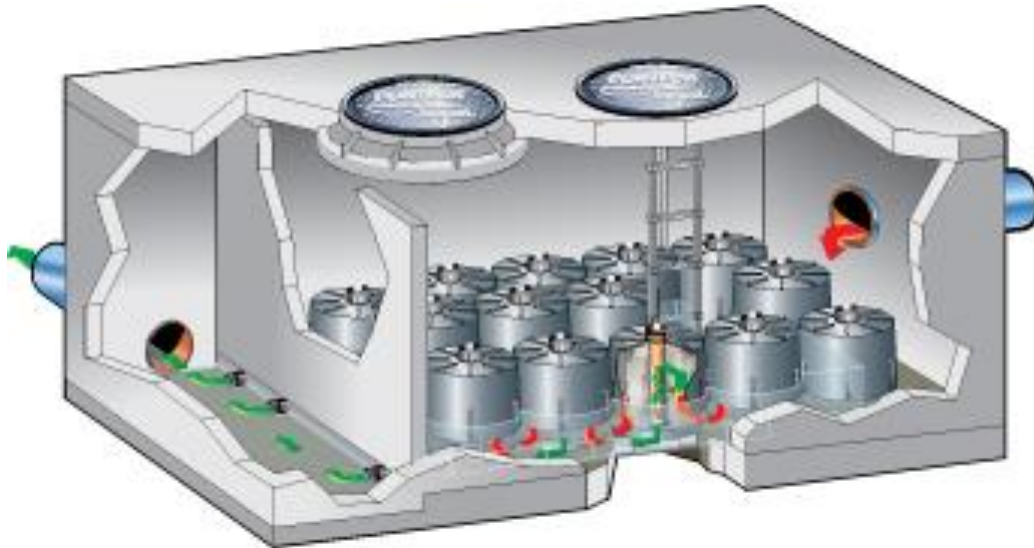

Design Objective

A StormFilter shall be designed to capture the design storm and release it slowly via a properly design outlet structure. Stormwater shall have an adequate flow path to bring about removal of TSS (all media types) and nutrients (using Phosphosorb media) through media filtration. The StormFilter shall be designed in a manner that protects the device, the areas around the device and the receiving stream from erosion. The StormFilter also must be maintained properly to ensure proper functioning.

Design Volume

The sizing for the StormFilter system is in conjunction with upstream closed detention based on designing the system to provide capture and treatment of 75% of the first 1.0" rainfall or the first 1.5" rainfall in coastal counties. No upstream open retention or upstream infiltration is permitted as treatment shall be directed to the cartridges.

Important Links

SCM Credit Document, D.1. Credit for StormFilter

Figure 1: StormFilter Cartridge

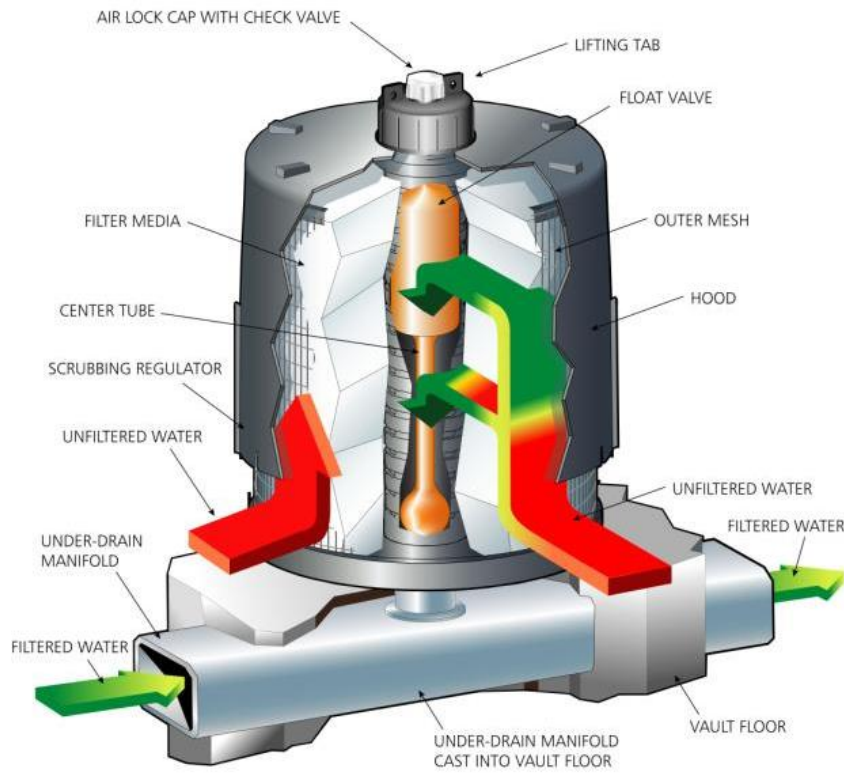
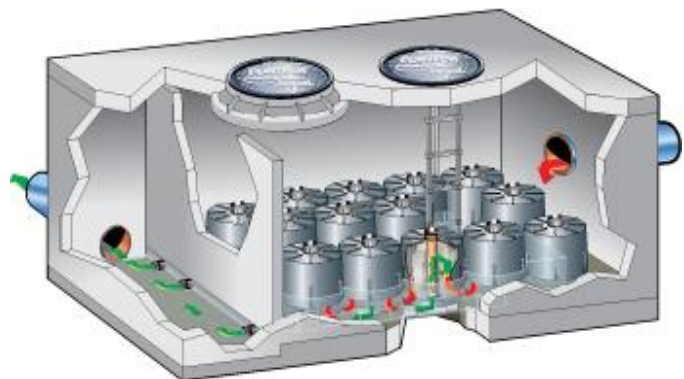

Figure 2: Standard Configurations (Vault and Manhole)



Guidance on the MDC

MDC 1. VOLUME BASED SIZING.

The sizing for the StormFilter system is in conjunction with upstream closed detention based on designing the system to provide capture and treatment of 75% of the first 1.0" rainfall or the first 1.5" rainfall in coastal counties. No upstream open retention or upstream infiltration is permitted as treatment shall be directed to the cartridges.

Determining the number of cartridges required is a dual design process where:

- First, the maximum treatment rate (as below) shall not be exceeded for a 24-hour minimum draw down.
- Secondly, a mass removal calculation is performed to determine an anticipated maintenance cycle for the cartridges that will be a minimum of 1 year. See Table 1 below for Contech's assumptions regarding influent concentrations of TSS.

Table 1: Assumed Influent Concentrations of TSS

Type of Land Use	Assumed Influent Concentration of TSS
Residential	60 mg/L
Commercial	70 mg/L
Industrial	100 mg/L

MDC 2. MEDIA FLOW RATE

The StormFilter Media Flow Rate shall be 1 GPM/ft² of Media Surface.

After the number of cartridges has been determined, a single, equivalent orifice calculation can be provided by Contech to the designer in order to assist in modeling the StormFilter in routing calculations. The equivalent orifice calculation is based on the flow rate as specified above, the number of cartridges, and the available driving Head (H). H is defined as the height of water in the system above the orifice (in feet).

MDC 3. SEDIMENTATION

The System Pretreatment Credit shall be 30% if system includes a minimum sediment sump with minimum dimensions of 4' diameter by 2' deep.

The sediment sump is normally located at the inlet(s) of the upstream detention system.

MDC 4. MEDIA TYPE

In Nutrient Sensitive Watersheds (NSW) and for Nutrient removal credit, Phosphosorb® Media shall be used. In all other areas, Perlite Media shall be used.

Phosphosorb® is a lightweight media comprised of Perlite (a heat-expanded volcanic rock) and activated alumina, removes total phosphorus (TP) by absorbing dissolved phosphorus and filtering particulate phosphorus simultaneously. Perlite is a natural, volcanic ash, similar in composition to glass and similar in appearance to pumice. It is heated during the manufacturing process to yield a lightweight, multicellular, expanded form.

The type of media shall be designated in print on the top cap of each cartridge (see example in Figure).

Figure 3: StormFilter Cap with Media Type

**MDC 5. MAINTENANCE**

Maintenance shall be performed per Contech Engineered Solutions Operation and Maintenance Instructions and performed by Certified Maintenance Providers.

The StormFilter Inspection and Maintenance Guide can be found at the following link: <http://www.conteches.com/products/stormwater-management/treatment/stormwater-management-stormfilter#1993310-technical-info>

A listing of certified maintenance providers can be found at the following link: <http://www.conteches.com/Products/Stormwater-Management/Service-Provider-List/StormFilter?state=NC>